



Proceedings

**10th Göttingen Meeting of the
German Neuroscience Society**

March 13–16, 2013

**34th GÖTTINGEN
NEUROBIOLOGY CONFERENCE**



Index

Plenary Lectures

Symposia

Poster Topics

Author Index

Plenary Lectures

- P1** Computational Principles for Cortical Circuits
Haim Sompolinsky
- P2** Genetic architecture of Parkinson's Disease
Thomas Gasser
- P3** Decoding the visual cortex
Nathalie Rochefort
- P4** Optogenetics in non-human primates
Ilka Diester, Karl Deisseroth, Krishna Shenoy
- P5** Principles of Neural Ensemble Physiology
Miguel Nicolelis
- P6** Transcriptomes and Proteomes at Synapses
Erin M. Schuman
- P7** What are they looking at? Imaging activity in the freely moving rodent from the eye to the cortex.
Jason ND Kerr
- P8** Variability, Compensation, Modulation, and Homeostasis in a Rhythmic Neuronal Network
Eve Marder
- P9** Shifting paradigms in neuropsychiatry
Hannelore Ehrenreich

Computational Principles for Cortical Circuits

Haim Sompolinsky¹

¹The Hebrew University, The Edmond and Lily Safra Center for Brain Sciences, Jerusalem, Israel

Abstract not available

Genetic architecture of Parkinson's Disease

Thomas Gasser¹

¹Neurologische Univ.-Klinik, Neurodegeneration, Hoppe-Seyler-Str. 3, 72076 Tübingen, Germany

The discovery of several genes causing inherited forms of Parkinson's Disease (PD) has provided important insights into the molecular mechanisms leading to the degeneration of dopaminergic neurons. More recently, advances in high throughput genetic technologies has allowed to focus on the contribution of gene variants to the development of the much more common sporadic forms of PD. Genome-wide association studies (GWAS) have shown that common variability of the genes involved in the Mendelian forms of PD, but also at a growing number of other genetic loci, also can predispose to the sporadic disorder. As the majority of these variants are not located in the coding regions of genes, their effect is most likely mediated by alterations of the regulation of gene expression.

Another segment of genetic variability contributing to this complex disease appears to be rare genetic variants of moderate effect, such as the recently described mutations in the gene for glucocerebrosidase (GBA). The existence of many more of these variants may be suspected and they are likely to be discovered by whole exome sequencing efforts.

Despite this remarkable progress, a considerable proportion of the total population disease risk is still unexplained. Studies on gene-gene and gene-environment interactions are very likely to provide important additional information, but have just begun to attempt to fill this gap.

Nevertheless, a coherent picture of molecular pathways is beginning to emerge that will provide "genetic entry points" to develop novel therapeutic targets on an individualized basis.

Decoding the visual cortex

Nathalie Rochefort¹

¹Technische Universität München, Institute for Neuroscience, Biedersteiner strasse 29, 80469 Munich, Germany

Brain functions such as sensations and thoughts depend on the coordinated activity of neuronal networks in precise spatial and temporal sequences. The aim of my work is to reveal the mechanisms underlying such coordinated cortical activity. I have focused my studies on the first cortical area reached by visual inputs, the primary visual cortex. I have used an in vivo imaging method, two-photon calcium imaging, combined with electrophysiological recordings. This approach allowed me to study the spontaneous and visually-evoked activity in the mouse primary visual cortex, both at the level of neuronal populations as well as at the level of individual dendrites and spines.

Optogenetics in non-human primates

Ilka Diester¹, Karl Deisseroth², Krishna Shenoy³

¹Ernst Strüngmann Institute (ESI) for Neuroscience in Cooperation with Max Planck Society, Sensory-motor circuits and Optogenetics, Deutschordenstr. 46, 60528 Frankfurt, Germany

²Howard Hughes Medical Institute, Department of Bioengineering, Department of Psychiatry and Behavioral Sciences, Stanford University, USA

³Departments of Electrical engineering, Neurobiology & BioEngineering, Stanford University, USA

The recording of single cell responses with electrophysiological methods is well established and allows as the only method measurements of electrical activity of neurons with a high spatial and temporal precision. However, to make causal claims about the tasks of a specific neuron type a method is needed which allows the fast and selective manipulation of neurons. Recently, the new technology of optogenetics was developed which allows a targeted manipulation of neuronal signals with highest precision. Optogenetics combines genetical and optical techniques to stimulate specified cell types and neural circuits with light. Light sensitive membrane proteins (so called opsins) get integrated into the cell membranes of neurons, thus rendering the neurons light sensitive. This allows activating or silencing them with specific wavelength. Optogenetics is already well established in rodents; however not yet in non-human primates. We will present data making optogenetics available for research in primates. First, primate specific promoters are needed as well as efficient and safe viral vectors to deliver the opsins into neurons. We will demonstrate the use of two viral vector systems, combined with human neuron-specific promoters, leading to strong opsin expression in cortical cell bodies and projecting axons in monkeys. Further, we will provide data showing that very low light levels are sufficient to activate opsin-expressing cells (e.g., channelrhodopsin-2) as measured at the single cell level. This is an important finding since very high light power can have a thermal impact on the surrounding tissue. To take this notion to a more extreme, we introduced the so called step function opsin (SFO) in the primate cortex. This opsin is able to accumulate light over several pulses due to its slow kinetics. Therefore it needs only very small amounts of light and leads to a stepwise increase of neural activity when several pulses are delivered. Hence, this opsin is particularly well-suited for experiments in which an increased excitability of a brain area is required. For other types of experiments it is necessary to inhibit neural activity. To that aim we tested the inhibitory opsin Halorhodopsin in rhesus monkeys. Again, small amounts of light are sufficient to completely inhibit the activity of opsin-expressing neurons. In order to find suitable stimulation sites and to evaluate the success of the expression, we developed an *in vivo* fluorescence meter which allows measuring expression strengths in the awake animal. A further difficulty in monkeys is the lack of transgenic models and our limited knowledge about cell type specific promoters. To still be able to limit the opsin expression to specific neuron population and to be able to specifically stimulate neural circuits, we developed a method which is based on the projections between brain areas. The capacity to record, activate and silence groups of neurons based on location, projection pattern, and functional type in non-human primates with their advanced cognitive and motor skills and intricate neural circuits provides unprecedented power to understand the brain's complex working principles.

Principles of Neural Ensemble Physiology

Miguel Nicolelis¹

¹Duke University, Neurobiology, Box 3209 Duke Medical Center, 27710 Durham, USA

²Duke University, Biomedical Engineering, Box 3209 Duke Medical Center, 27710 Durham, USA

³Duke University, Psychology and Neuroscience, Box 3209 Duke Medical Center, 27710 Durham, USA

In this talk, I will describe how state-of-the-art research on brain-machine interfaces make it possible for the brains of primates to interact directly and in a bi-directional way with mechanical, computational and virtual devices without any interference of the body muscles or sensory organs.

I will review a series of recent experiments using real-time computational models to investigate how ensembles of neurons encode motor information. These experiments have revealed that brain-machine interfaces can be used not only to study fundamental aspects of neural ensemble physiology, but they can also serve as an experimental paradigm aimed at testing the design of novel neuroprosthetic devices. I will also describe evidence indicating that continuous operation of a closed-loop brain machine interface, which utilizes a robotic arm as its main actuator, can induce significant changes in the physiological properties of neural circuits in multiple motor and sensory cortical areas. This research raises the hypothesis that the properties of a robot arm, or other neurally controlled tools, can be assimilated by brain representations as if they were extensions of the subject's own body.

Transcriptomes and Proteomes at Synapses

Erin M. Schuman¹

¹Max Planck Institute for Brain Research, Synaptic Plasticity, Max-von-Laue-Str. 4, 60438 Frankfurt am Main

An individual neuron in the brain possesses approximately 10,000 synapses, many of which are hundreds of microns away from the cell body, which can process independent streams of information. During synaptic transmission and plasticity, remodeling of the local proteome occurs via the regulated synthesis of new proteins. I will discuss previous and current studies aimed at understanding how the local transcriptome, obtained with deep sequencing, and the local proteome, obtained with BONCAT, might influence synaptic transmission and plasticity.

What are they looking at? Imaging activity in the freely moving rodent from the eye to the cortex.

Jason ND Kerr¹

¹Max Planck Institute for Biological Cybernetics, Network Imaging Group, Spemannstrasse 41, 72076 Tuebingen, Germany

Rats are binocular animals and although their eyes are located laterally on the head they have a very large region of binocular overlap that extends from below their snouts to behind their head. How this enormous binocular field behaves as the animal navigates through an environment and what advantage this provides is completely unknown because to date there have been no recordings of the movements of both eyes in a freely moving rodent. Eye movements in head-restrained rats are conjugate similar to those of primates, but studies of the vestibular-ocular reflex in rats suggest that this only describes a fraction of their eye movements. Our lab studies how rodents use their vision to make decisions and the cortical circuits that are activated. Studying the cortex in the freely moving animal gives not only gives access to the suite of systems that allows the animal to make sense of the surrounding environment but it also enables the measurement of the behavioral strategies the animal uses when making decisions. In order to measure both activity from cortical populations and head and eye positions in the freely moving animal we further developed our miniature 2-photon microscope to include two lightweight cameras for ocular videography and a head tracking system. Using this approach we show that movements of the two eyes in freely moving rats differ fundamentally from the precisely controlled eye movements used by other mammals to maintain continuous ocular alignment.

Variability, Compensation, Modulation, and Homeostasis in a Rhythmic Neuronal Network

Eve Marder¹

¹Brandeis University

Neurons and networks must constantly rebuild themselves in response to the continual and ongoing turnover of all of the ion channels and receptors that are necessary for neuronal signaling. A good deal of work argues that stable neuronal and network function arises from homeostatic negative feedback mechanisms. Nonetheless, while these mechanisms can produce a target activity or performance, they are also consistent with a good deal of recent theoretical and experimental work that shows that similar circuit outputs can be produced with highly variable circuit parameters. This work argues that the nervous system of each healthy individual has found a set of different solutions that give “good enough circuit performance. Studies using the crustacean stomatogastric nervous system argue that synaptic and intrinsic currents can vary far more than the output of the circuit in which they are found. These data have significant implications for the mechanisms that maintain stable function over the animal’s lifetime, and for the kinds of changes that allow the nervous system to recover function after injury.

Shifting paradigms in neuropsychiatry

Hannelore Ehrenreich¹

¹Max Planck Institute of Experimental Medicine, Clinical Neuroscience, Hermann-Rein-Str. 3, 37075 Göttingen, Germany

Neuropsychiatric diseases ranging from affective disorders, schizophrenia and autism to dementias are diagnosed merely clinically, based on classification systems of mental diseases. Biomarkers or reliable neuropathological features to support these diagnoses are missing. Modern imaging technologies, despite revealing brain matter loss or functional alterations, have not yet assisted in defining objective diagnostic criteria. These, however, will be essential for developing causal therapies.

Relying on the 'umbrella diagnoses' of classification systems, genetic analyses including genome-wide association studies (GWAS) were undertaken but failed to provide insight into the biological basis of these very heterogeneous diseases. 'Risk genotypes' of unknown significance and low odds ratios of mostly <1.2 were extracted and confirmed by including ever increasing numbers of individuals in large multicenter efforts. As expected, the low odds ratios persisted. Importantly, most of the so identified 'robust' GWAS risk markers or otherwise detected 'disease genes', e.g. DISC1, do not respect disease borders but are associated with affective diseases, schizophrenia, autism, dementias, personality disorders or mental health.

Hence, schizophrenia and other neuropsychiatric diseases are highly complex, multigenetic diseases with numerous potential environmental co-factors influencing disease onset and course. We hypothesize that hundred thousands of genetic constellations - together with environmental 'second hits' - are able to cause the individual disease. This explicates why incidence and prevalence of mental diseases are so high and why mutations, including copy number variations, explain only a tiny part of variance.

A considerable proportion of the population across cultures (likely 50%) may harbor the genetic make-up for developing a mental disease whereas the remaining 50% of individuals could never acquire it due to absence of respective genetic prerequisites. Only in a small fraction of risk carriers the disease will break out, co-induced by a multitude of external inputs, while the bulk of carriers will stay healthy and forward their predisposition to following generations.

Lack of biologically based diagnoses and non-existence of disease genes force us to re-consider our approach to mental diseases. A 'start from scratch' by elucidating the contribution of genotypes to phenotypes and so re-defining disease entities will be tough but crucial. We have termed this approach PGAS ('phenotype-based genetic association study'). Ultimate goal is the definition of biological subgroups of mental diseases. For that purpose, the GRAS (Göttingen Research Association for Schizophrenia) collection was initiated in 2005. With >3000 phenotypical data points per patient, it comprises the world-wide largest currently available database of phenotypically well characterized schizophrenic patients (N>1200), obtained under highly standardized conditions by one clinical research team. Most GRAS patients agreed to be re-visited for follow-up studies.

As first proof-of-principle for this novel, labor-intense direction, an autistic subphenotype of schizophrenia has been defined where an unfortunate accumulation of frequent normal genotypes, so-called pro-autistic variants of synaptic genes, explains a high percentage of phenotypical variance. Along these lines, a psychomotor and a schizoaffective subphenotype of schizophrenia are presently genetically characterized.

Symposia

- S1 The cholinergic system and visual attention: From animal to man
- S2 Local synaptic coding in the Retina
- S3 The computational role of the hippocampus
- S4 Non-invasive brain stimulation: mechanisms, effects and opportunities
- S5 "The paradox of the critical period" – rejuvenating cortical networks
- S6 Mouse models in hearing research: unraveling auditory processing from molecules to behavior
- S7 Functional organization of presynaptic neurotransmitter release sites
- S8 Neurochemical control of social behaviour insects
- S9 Timescales in neuronal population encoding and their biophysical basis
- S10 Differential brain science: towards an understanding of interindividual variation
- S11 Serotonin: from brain development to behavior - new insights from animal models.
- S12 Cytoskeletal dynamics in neuronal migration
- S13 Olfactory learning: from insects to machines
- S14 Molecular Mechanisms and Spreading of alpha-synuclein pathology in the brain
- S15 Cortical connectivity of crossmodal interactions
- S16 Growing up in the brain: how do axons find their way?
- S17 Heterogeneity of microglia
- S18 Optodynamics of channels and receptors
- S19 GABAergic mechanisms in neurobiology of disease
- S20 Functional specializations of neuroglia as critical determinants of brain activity

S21 Molecular mobility, a variable of neuronal communication

S22 Insect motor control- From ion channels to learning, movement and robotics

S23 Purinergic signaling in sensory systems

S24 Practically profiting from the complexity of massively parallel electrophysiological data

Symposium

S1: The cholinergic system and visual attention: From animal to man

- S1-1** Cholinergic Neuropharmacology of visual attention
Alexander Thiele
- S1-2** Basal forebrain stimulation regulates contrast sensitivity in primary visual cortex
Gregor Rainer
- S1-3** Laminar aspects of cholinergic effects on primary visual cortex
Julia Veit
- S1-4** Cholinergic modulation of visual perception in rodents
Elvire Vaucher
- S1-5** Cholinergic Enhancement of Visual Attention and Neural Oscillations in the Human Brain
Markus Bauer, Christian Kluge, Dominik Bach, Raymond J Dolan, Jon Driver
- S1-6** Cholinergic modulation of visual attention as assessed with pharmacological fMRI
Christiane M Thiel

Cholinergic Neuropharmacology of visual attention

Alexander Thiele¹

¹Newcastle University, Institute of Neuroscience, Framlington Place, NE2 4HH Newcastle upon Tyne, United Kingdom

Attention exerts a strong influence over neuronal processing in cortical areas. In V1, the attentional modulation of firing rates is dependent on cholinergic (muscarinic) mechanisms ¹, suggesting an involvement of cholinergic inputs from the basal forebrain. However, the traditional assumption is that attention is implemented through top-down feedback from higher cortical areas, where cholinergic modulation of attentional signals might equally be effective and where nicotinic receptors might be involved too. We show that cholinergic modulation of neuronal activity in area V4 and FEF is stronger than in area V1. It is largely similar between area V1 and V4, but it has different signatures in FEF. Finally we investigated the implementation of presumed feedback at the transmitter/receptor level targeting the glutamatergic (NMDA receptors and non-NMDA receptors) system. We show that ionotropic glutamatergic receptor activation is required for attention induced rate variance, noise correlation and LFP gamma power reduction in macaque V1, but not for attention induced rate modulations. Conversely, ACh exclusively affects the rate modulation, not the variance and covariance modulations in V1. Our results demonstrate that attention improves sensory processing by a variety of mechanisms which are dissociable at the receptor level.

¹ Herrero, J. L. et al. Acetylcholine contributes through muscarinic receptors to attentional modulation in V1. *Nature* 454, 1110-1114 (2008).

Basal forebrain stimulation regulates contrast sensitivity in primary visual cortex

Gregor Rainer¹

¹University of Fribourg, Department of Medicine, Chemin du Musée 5, 1700 Fribourg, Switzerland

The basal forebrain (BF) regulates cortical activity by the action of cholinergic projections to the cortex. At the same time, it also sends substantial GABAergic projections to both cortex and thalamus, whose functional role has received far less attention. We used deep brain stimulation (DBS) in the BF, which is thought to activate both types of projections, to investigate the impact of BF activation on V1 neural activity. The spontaneous V1 local field potential often exhibited spectral peaks centered at 40 and 70Hz as well as reliably showing a broad gamma-band (30-90Hz) enhancement following BF stimulation, whereas effects in a low frequency band (0.1-10Hz) were less consistent. BF stimulation robustly enhanced V1 unit activity, led to moderate decreases in orientation selectivity and a remarkable enhancement in contrast sensitivity. The broad gamma-band, rather than low frequency activity or spectral peaks was the best predictor of both the firing rate increase and contrast sensitivity enhancement of V1 unit activity. We argue that in addition to cholinergic modulation, the BF GABAergic projections play a crucial role in the impact of BF DBS on cortical activity.

Laminar aspects of cholinergic effects on primary visual cortex

Julia Veit¹

¹University of Fribourg, Medicine, Chemin du Musée 5, 1700 Fribourg, Switzerland

The distribution of nicotinic and muscarinic cholinergic receptors in cortex across cortical layers together with the termination pattern of cholinergic projections is thought to have a major influence on how the basal forebrain (BF) cholinergic activation impacts information processing in the cortex. We present data from laminar -specific pharmacological activation of each receptor type as well as BF deep brain stimulation for both spontaneous and visually driven V1 activity. Nicotinic activation had largest effects in the granular cortical input layer, strongly enhancing both spiking and local field potentials consistent with a high density of nicotinic receptors on thalamo-cortical afferents. Muscarinic activation, as well as BF stimulation, most strongly impacted infragranular layers - particularly for spontaneous activity - consistent with the termination of BF cholinergic axons preferentially targeting these layers. Our findings highlight the diverse nature of cholinergic neuromodulatory impact on cortical processing that depends heavily on cortical layer and cholinergic receptor type.

Cholinergic modulation of visual perception in rodents

Elvire Vaucher¹

¹Université de Montréal, School of optometry, CP 6128 succursale centre-ville, H3C 3J7 Montreal, Canada

Acetylcholine has been shown associated with visual attention and learning mechanisms in the primary visual cortex (V1). This neurotransmitter modulates neuronal responses and cortical plasticity through muscarinic and nicotinic receptors. Particularly, activation of the cholinergic system paired with visual stimulation induces a long-term increase of visual evoked potentials (VEP) through muscarinic receptors. The present study investigated whether such visual-cholinergic pairing could result in behavioral change, i.e. improved visual performance in rats. Visual acuity for a non-optimal sinusoidal grating (30° orientation, which elicits responses in a small population of in V1 neurons in naïve animals), was tested before and after two -week paired visual -cholinergic training. Moreover, it was examined whether muscarinic receptor (mAChR) deletion could modify the functional organization of V1 in mAChR KO mice.

Basal visual acuity of Long-Evans rats was measured using the visual water maze. Daily visual training (sinusoidal grating, 0.12 cycle/degree, 30° orientation) paired or not with electrical cholinergic stimulation was then performed during the two weeks in controls and rats with a 192 -IgG saporin-induced cholinergic deficit. The post-training visual acuity as well as VEP were measured. The visual cortex of urethane anesthetized mice lacking M1, M1/M3 or M2/M4 mAChRs and wild type animals was imaged by in vivo optical imaging of intrinsic signals to measure the sensitivity of the mice to spatial frequency and contrast, as well as retinotopic maps along elevation and azimuth.

The mean baseline visual acuity to the 30° orientation grating prior to any experiment was 0.73 ± 0.06 cycle/degree. Only the visual -cholinergic stimulated group showed a significant enhancement of this value (0.87 ± 0.04 cycle/degree, $p < 0.05$, one-way ANOVA), with orientation selectivity. The other groups (control, visual stimulation alone, cholinergic stimulation alone or 192-IgG saporin cholinergic deficit) did not show any enhancement of visual acuity. Analysis of VEP as a measure of neuronal activity also indicated a significant increase in amplitude of the response in V1 of the visual-cholinergic stimulated group (348 vs 156 μ V, $p < 0.05$). Altered retinotopic map and sensitivity of V1 was detected in mAChRs KO mice. The spatial frequency sensitivity and receptor field index were decreased in M1 -KO and M1/M3-KO and the scatter along azimuth (index of good neural connectivity) was increased in M2/M4-KO mice compared to WT.

Our results demonstrated that the pairing of the cholinergic system activation with visual training improved the visual performance of the animals. This might be explained by the role of mAChRs in the functional organization of V1. These results confirm that the increase of cortical response induced by cholinergic activity plays a significant role in visual learning. This study opens the possibility of establishing efficient rehabilitation strategies for facilitating visual recovery.

Cholinergic Enhancement of Visual Attention and Neural Oscillations in the Human Brain

Markus Bauer¹, Christian Kluge², Dominik Bach³, Raymond J Dolan⁴, Jon Driver⁵

¹UCL, Wellcome Trust Centre for Neuroimaging, 12 Queen Square, WC1N3BG London, United Kingdom

Cognitive processes such as visual perception and selective attention induce specific patterns of brain oscillations. The neurochemical basis of these orchestrated spectral changes in neural activity remains unknown, but neuromodulators are thought to regulate processing. The cholinergic system is linked to attentional function *in vivo*, while separate *in-vitro* studies found cholinergic agonists induce high-frequency oscillations in slice preparations, leading to theoretical proposals that cholinergic enhancement of visual attention might operate via gamma oscillations in visual cortex. Here we applied a cholinergic agonist (physostigmine) during a spatial visual attention task in humans, while recording cortical oscillations. The cholinergic agonist enhanced attentional lateralization of low-frequency alpha/beta oscillations in visual cortex. This related closely to the drug-induced enhancement of performance. By contrast, the cholinergic agonist did not alter high-frequency gamma oscillations in visual cortex. The attention related lateralisation in alpha-power was accompanied by hemisphere-specific oscillatory coupling between frontal, parietal and occipital areas in the alpha-bands. Like the observed attentional modulation of alpha-power, this coupling was strengthened by the cholinergic agonist.

The observed results will be discussed in the context of a neural model relating the observed results and the dissociation between high and low frequency bands to layer specific activation patterns associated with feedback and feedforward projections.

Cholinergic modulation of visual attention as assessed with pharmacological fMRI

Christiane M Thiel¹

¹University of Oldenburg, Department of Psychology, Ammerländer Heer Str 114-118, 26111 Oldenburg, Germany

In recent years the rapidly growing use of functional magnetic resonance imaging (fMRI) in conjunction with psychopharmacology has increased our knowledge about brain mechanisms underlying the cholinergic modulation of attention. The talk will deal with the role of the cholinergic agonist nicotine in selective attention in humans. In a series of pharmacological fMRI studies in healthy volunteers, we were able to demonstrate that the cholinergic agonist nicotine reduces the time needed for reorienting visuospatial attention. This was accompanied by a reduction of the fMRI signal in the posterior parietal cortex. Using multivariate data analyses we were further able to show that the behavioural effects of nicotine can be predicted by brain activity under placebo. Genetic fMRI studies additionally suggest that depending on CHRNA4 genotype, different brain networks are used for reorienting selective attention. Finally I will address the use of resting state fMRI studies and graph analytical approaches in understanding how nicotine modulates human brain activity.

Symposium

S2: Local synaptic coding in the Retina

- S2-1** Synaptic interactions in the outer retina of the mouse
Robin Kemmler, Thomas Euler, Timm Schubert

- S2-2** Using fluorescent proteins to investigate synaptic transmission of visual information
Leon Lagnado, Anton Nikolaev

- S2-3** The bipolar cell terminal as a selective spatio-temporal filter
Tom Baden, Philipp Berens, Matthias Bethge, Thomas Euler

- S2-4** Local computations in dendrites and axons of the inner retina.
Robert G Smith

- S2-5** Feedback mechanisms of rod bipolar cells in the healthy and diseased retina
Espen Hartveit, Aurea Castilho, Eirik Madsen, Margaret Veruki

- S2-6** Synaptic circuitry of a small bistratified amacrine cell in primate retina
Sonja Neumann, Marek Zajac, Christian Puller, Maureen Neitz, Silke Haverkamp

- S2-7** Changes in the synchrony of cross-synaptic output of a retinal neuron
William N Grimes, Fred Rieke

Synaptic interactions in the outer retina of the mouse

Robin Kemmler¹, Thomas Euler¹, Timm Schubert¹

¹Centre for Integrative Neuroscience, Ophthalmic Research, Otfried-Müller-Str. 25, 72076 Tübingen, Germany

Introduction/Methods

At the very first synapse of the visual system, the photoreceptor synapse, horizontal cells (HCs) provide inhibitory feedback to cone photoreceptors (cones). This feedback is thought to dynamically adapt the working range of cones to the ambient light and to contribute an outer retinal component to the generation of antagonistic receptive fields. Based on data from different vertebrate species, three distinct types of mechanisms have been proposed to be involved in the feedback from HCs to cones: hemichannel-based ephaptic, pH-mediated and GABAergic feedback (reviewed in Thoreson and Mangel, *Prog Retin Eye Res*, 2012). The present study aims at investigating which of these feedback mechanisms are present in the mouse retina and, in case there are multiple candidates, whether these mechanisms operate in parallel or under different conditions. As all feedback mechanisms described so far modulate cone output, our approach was to assess the effect of HC feedback on light-evoked Ca²⁺ responses measured in cone terminals of a transgenic mouse using two-photon microscopy. In this mouse line (HR2.1:TN-XL; Wei et al., *J Neurosci*, 2012), cones selectively express the Ca²⁺ biosensor TN-XL under the control of the human red opsin promoter. Feedback mechanisms were pharmacologically dissected using light stimuli of different polarity (stimuli darker or brighter than background light intensity) and contrast.

Results

Application of Carbenoxolone, a gap junction blocker, increased both resting Ca²⁺ level and amplitude of light-evoked Ca²⁺ responses, suggesting the presence of hemichannel-mediated ephaptic feedback in mouse. Clamping extracellular pH with HEPES reversibly reduced the initial peak of dark-evoked Ca²⁺ responses, which argues against an involvement of protons in inhibitory feedback from HCs to cones but rather suggests that protons play a role in an “excitatory” feedback mechanism shaping cone responses to dark flash-stimuli. Finally, preliminary experiments in which we mimicked a potential GABAergic feedback mechanism by applying GABA, decreased the amplitude of light-evoked Ca²⁺ responses, consistent with the GABAergic HC feedback hypothesis.

Conclusions

Our data support the presence of ephaptic and GABAergic feedback functioning as inhibitory feedback mechanisms in the mouse retina. A pH-mediated mechanism, however, may provide “facilitory” feedback from HCs to cones. Thus, all three feedback mechanisms may be employed in the outer retina to shape the synaptic output from cones.

Support: DFG (EXC 307; CIN Pool Project 2011-05)

Using fluorescent proteins to investigate synaptic transmission of visual information

Leon Lagnado¹, Anton Nikolaev¹

¹MRC Laboratory of Molecular Biology, Neurobiology Division, Hills Road, CB2 0QH Cambridge, United Kingdom

Synapses are perhaps the most numerous computational elements within neural circuits. The process of chemical transmission can transform neural signals and, because synapses are plastic, these transformations can be altered over different time-scales to adjust the input-output relation of the circuit as a whole. We therefore need to assess the activity of large populations of synapses if we want to understand how neural circuits function. I will describe two experimental strategies that allow the synaptic basis of circuit function to be studied *in vivo* by imaging of genetically-encoded reporters. The first uses a pHluorin-based reporter of synaptic vesicle fusion (Miesenböck et al., 1998; Granseth et al., 2006), and the second is the localization of genetically-encoded calcium indicators to presynaptic terminals (Dreosti et al., 2009). I will illustrate how these reporters can be used to analyze circuit function with examples drawn from our work on the synaptic processing of visual information in the retina (Dreosti et al., 2011; Baden et al., 2011; Odermatt et al., 2012). These strategies are allowing us to investigate how populations of synapses encode and transform the visual signal in the retina, revealing how the visual signal is first converted from an analogue format into spikes, and the mechanisms of synaptic plasticity that alter the input-output relation of the retinal circuit.

1. Baden, T., F. Esposti, A. Nikolaev, and L. Lagnado. (2011). Spikes in retinal bipolar cells phase-lock to visual stimuli with millisecond precision. *Current Biology*, 21: 1859-1869.
2. Dreosti, E., B. Odermatt, M.M. Dorostkar, and L. Lagnado. (2009). A genetically encoded reporter of synaptic activity *in vivo*. *Nature Methods*, 6: 883-889.
3. Dreosti, E., F. Esposti, T. Baden, and L. Lagnado. (2011). *In vivo* evidence that retinal bipolar cells generate spikes modulated by light. *Nature Neuroscience*, 14: 951-952.
4. Granseth, B., B. Odermatt, S.J. Royle, and L. Lagnado. (2006). Clathrin-mediated endocytosis is the dominant mechanism of vesicle retrieval at hippocampal synapses. *Neuron*, 51: 773-786.
5. Miesenböck G, De Angelis DA, Rothman JE (1998). Visualizing secretion and synaptic transmission with pH-sensitive green fluorescent proteins. *Nature*, 394:192-5.
6. Odermatt, B., A. Nikolaev, and L. Lagnado. (2012). Encoding of luminance and contrast by linear and non-linear synapses in the retina. *Neuron*, 73: 758-773.

The bipolar cell terminal as a selective spatio-temporal filter

Tom Baden^{1,2}, Philipp Berens^{1,3}, Matthias Bethge^{1,3}, Thomas Euler^{1,2}

¹University of Tübingen, CIN/BCCN, Otfried Müller Str. 25, 72076 Tübingen, Germany

²Institute for Ophthalmic Reserach

³MPI for Biol. Cybernetics

The visual signal impinging on the photoreceptor array is passed through a series of spatio-temporal filters at the level of bipolar and ganglion cells before being passed to the brain as ~20 parallel representations of the visual world. Key processing steps occur within the retina's two synaptic layers, the outer and inner plexiform layers (OPL, IPL). In the OPL of the mouse retina, dendrites of ~10-12 different types of bipolar cells integrate visual information forwarded from photoreceptors, under modulatory control of horizontal cells, setting up the initial building blocks from which complex "trigger features" are subsequently extracted by retinal ganglion cells in the IPL. Here, lateral inputs from amacrine cells directly impinge on ganglion cell and bipolar cell synapses further shaping the visual signal. To understand the visual signal harbored in BC terminals is therefore pivotal to our understanding of retinal circuit function. We characterized the ex-vivo light-response properties of mouse BC types by calcium imaging of synaptic terminals in the whole-mount retina and found that BCs can be reliably clustered based on their temporal properties and their propensity to generate spikes alone. The identified functional BC outputs are organized in a kinematopic map across different IPL strata, with fastest projecting centrally and slower cells projecting to either edge. Moreover, the fastest BC types generate all-or-nothing spikes, thereby enhancing time-precise processing of visual signals in the retina. But bipolar cells typically possess in the order of 20-30 individual axonal terminals, with potentially different intrinsic properties, at different electrotonic distance from the axon, each under modulatory control by a potentially different subset of amacrine cells. This suggests that individual bipolar cell terminals belonging to the same cell may represent differential space-time filters, thereby vastly expanding the wealth of signal diversity available to RGCs towards the extraction of highly specific trigger features. Indeed, already very basic properties of individual synapses, such as presynaptic bouton size fundamentally impact temporal processing by individual terminals (work on fish, collaboration with L Lagnado). Using 2P calcium imaging of light-evoked signals within individual terminals belonging to the same mouse BC we show that mouse bipolar cells systematically multiplex visual stimuli into distinct parallel channels represented by individual terminals (collaboration with R Smith and WR Taylor). Preliminary data suggests that key differences between signals forwarded by different terminals extend to the kinetic and polarity domain, rather than the spatial domain. Finally, we also estimate spatiotemporal receptive fields in individual postsynaptic sites along RGC dendrites under the same experimental conditions used for recording from BC terminals and complement our approach with population imaging of light-evoked calcium responses within RGC somata towards a more complete understanding of temporal processing in the mammalian retina.

Local computations in dendrites and axons of the inner retina.

Robert G Smith¹

¹University of Pennsylvania, Department of Neuroscience, Rm 123, Anat-Chem Bldg /6058, 422 Curie Blvd., 19104 Philadelphia, PA, USA

The retina contains multiple parallel channels that perform specific signal processing functions on visual signals. About 20 ganglion cell types derive their unique signals from ~10 bipolar cell types and more than 20 amacrine cell types. The signal processing is performed by local circuits mainly in the inner retina where each type of ganglion cell is thought to receive synaptic inputs from a unique microcircuit. But how synaptic inputs are summed and processed in local interactions within distal compartments of the cell is not well understood. Computational models can help, because over the past 4 decades they have shown that synaptic processing in dendrites can perform powerful signal processing functions.

Using a computational model, we showed that partial isolation of distal compartments in a neuron gives excitatory post-synaptic potentials in the dendritic tips a directional bias for centrifugal motion aligned with the dendrite's orientation. This "intrinsic DS" mechanism may be responsible for the initiation of directional signals in the starburst amacrine cell. We showed that the directional signal in the dendritic tip depends on partial electrotonic isolation from the soma, because with too much or too little isolation it is impaired. At the dendritic tip, Na channels amplify the directional signal, which controls the release of GABA that carries the directional signal to the direction-selective ganglion cell (DSGC).

The DSGC also relies on signal processing within partially isolated dendritic compartments. It receives excitatory and inhibitory synaptic inputs over its entire dendritic arbor, and the orientation of its dendrites also generates an intrinsic DS. Each dendritic compartment sums excitation and inhibition that are directional to some degree. Dendritic Na channels amplify the post-synaptic potentials when the balance of excitation and inhibition sufficiently depolarizes the local compartment. This highly nonlinear processing amplifies the directional difference, resulting in a spike train that is several-fold more directional than its synaptic inputs. This arrangement allows the cell to respond robustly to a small stimulus anywhere in its dendritic arbor.

Bipolar cells may perform a similar type of processing in their axonal arbors, for their axonal branches are very fine and can serve to isolate synaptic boutons. Recent reports have shown that the axonal arbors of some On and Off bipolar cell types can generate spikes, and inhibitory feedback onto a bipolar cell may originate in different types of amacrine cells. A computational model shows how local signal processing may function in the axon. A strong light response may generate a spike in the proximal axon that without inhibition can propagate reliably to all the terminal boutons. In very fine terminal branches, a spike propagating from the proximal axon can be blocked in distal boutons by strong inhibition. A weak light response that does not reach spike threshold can be modulated by local inhibition to generate different waveshapes in different terminal boutons. This mechanism allows a bipolar cell's output to be tuned simultaneously for different postsynaptic cells by its axonal morphology and the inhibitory feedback it receives.

Depending on the specific morphology of the cell and its biophysical properties, a dendrite or axon can be partially isolated from the soma, and thus can perform a variety of local computations independently.

Feedback mechanisms of rod bipolar cells in the healthy and diseased retina

Espen Hartveit¹, Aurea Castilho¹, Eirik Madsen¹, Margaret Veruki¹

¹University of Bergen, Department of Biomedicine, Jonas Lies vei 91, N-5009 Bergen, Norway

In the outer retina, rod and cone photoreceptors make glutamatergic ribbon synapses with rod and cone bipolar cells, respectively. Whereas cone bipolar cells can be classified into appr. 10 different populations with axon terminals that stratify at specific levels of the inner plexiform layer, rod bipolar cells seem to basically constitute a single type with axon terminals that stratify at a single stratum of the inner plexiform layer. ON- and OFF-cone bipolar cells mediate glutamatergic synaptic input to ON- and OFF-ganglion cells via ionotropic receptors at excitatory ribbon synapses in the inner plexiform layer. Rod bipolar cells instead make excitatory ribbon synapses with two different types of amacrine cells, termed A11 and A17. The synapses from rod bipolar cells onto these two types of amacrine cells occur as dyads, where a synaptic ribbon in the bipolar cell axon terminal is apposed simultaneously to two postsynaptic processes. The postsynaptic process belonging to the A17 amacrine cell provides a reciprocal synapse back onto the rod bipolar terminal, seemingly the only output from this amacrine cell. The A11 amacrine cells convey the rod visual signals by coupling into both the ON and OFF cone pathways: via sign-conserving electrical synapses to ON-cone bipolar cells and via sign-inverting inhibitory synapses to OFF-cone bipolar cells and OFF-ganglion cells.

There is strong evidence that the output from the rod bipolar axon terminals is controlled by several negative feedback mechanisms operating in parallel. These mechanisms act directly on the presynaptic axon terminal:

1. GABAergic feedback from the A17 amacrine cell, acting on GABA_A and GABA_C receptors on the rod bipolar axon terminals.
2. Activation of a glutamate transporter (EAAT5) associated with a non-stoichiometrically coupled chloride current.
3. Suppression of voltage-gated Ca²⁺ current by protons released during exocytosis of synaptic vesicles from rod bipolar cells.

We will review recent work from several laboratories that has elucidated important aspects concerning the detailed synaptic and molecular mechanisms involved in each of these actions, including their relative magnitude and functional importance. We will also discuss recent work from our laboratory that suggests how the GABAergic feedback from A17 amacrine cells can be changed during experimentally induced diabetes mellitus, potentially involving a change of the Ca²⁺ permeable AMPA receptors of the A17 amacrine cells.

Synaptic circuitry of a small bistratified amacrine cell in primate retina

Sonja Neumann¹, Marek Zajac¹, Christian Puller², Maureen Neitz², Silke Haverkamp¹

¹Max Planck Institute for Brain Research, Neuroanatomy Research Unit, Deutschordenstraße 46, 60528 Frankfurt am Main, Germany;

²University of Washington, Department of Ophthalmology, Seattle

Within the vertebrate retina light signals are transduced by photoreceptors and transmitted via bipolar and ganglion cells to higher visual areas of the brain. At each level of this canonical glutamatergic pathway, neurotransmission is strongly affected by GABAergic or glycinergic inhibition. This fundamental task in shaping basic neuronal response properties of the retina is accomplished by horizontal cells in the outer and amacrine cells in inner retina. Although around 30 different types of amacrine cells exist in the mammalian retina, only little is known about their individual connectivity and function besides some exceptions such as All or starburst amacrine cells.

Here we take an anatomical approach to investigate the connectivity of glycinergic small bistratified amacrine cells within the macaque monkey retina. The amacrine cells were labeled with antibodies against the protein synaptotagmin-2 (Syt2) in combination with different cell and synaptic markers. Previously, we found that this amacrine cell type receives both, On- and Off-bipolar cell input. A quantitative analysis revealed that the major source of Off-bipolar cell input originates from flat midget bipolars and from type 1 diffuse bipolar cells (DB1) (Neumann & Haverkamp, *J Comp Neurol*, 2012). Now, we investigated potential glycinergic feedback synapses onto these Off-bipolar cells using confocal imaging and electron microscopy. Furthermore, we are trying to shed light on glycinergic inhibition onto ganglion cells mediated by the small bistratified amacrine cell, using dye injections into single ganglion cells of different types in combination with immunolabelings against Syt2 and the glycine receptor subunits GlyRa1 and GlyRa2. First results show that the small bistratified amacrine cells provide glycinergic input onto the M1 melanopsin-expressing ganglion cell via GlyRa2.

In summary, we describe in detail the synaptic connectivity pattern of a small bistratified amacrine cell type and compare its circuitry with All amacrine cells of the rod pathway.

Support:

DFG grant HA5277/2-2

NEI EY09303, EY01730, NIH OD011189, Research to Prevent Blindness

Changes in the synchrony of cross-synaptic output of a retinal neuron

William N Grimes¹, Fred Rieke¹

¹HHMI/UofWa, Physiology and Biophysics, 1705 N.E. Pacific Street, 98195 Seattle, USA

Specific patterns of synchronous signaling within neural networks shape the efficacy of synaptic transmission, the development of highly-specific wiring configurations and computations that rely upon correlated network activity. Correlations in spontaneous network activity (i.e. in the absence of stimulus correlations) are driven by divergent output from upstream signaling/circuit components. Cross-synaptic synchrony -- correlations in transmitter release across output synapses of a single neuron—underlies network noise correlations and is a key determinant of the noise sources that limit the fidelity of signals traversing a neural circuit, yet it has been technically challenging to study cross-synaptic synchrony separately from other forms of synchrony. The anatomical connectivity between the rod bipolar and A17 amacrine cells in the mammalian retina provides a rare opportunity to make direct measurements of cross-synaptic synchrony under near-physiological conditions.

Unlike many neurons in the CNS, rod bipolar cells do not produce all-or-none spikes in presynaptic membrane potential, a mechanism for synchronizing transmitter release across synaptic boutons/outputs. Instead rod bipolar cells, in addition to many other sensory neurons, convey visual signals via graded changes in membrane potential. In the absence of a synchronizing mechanism, such as action potentials, it is largely unclear how synchronized output synapses would be under physiological conditions. By combining a quantitative inner-retinal wiring assessment with electrophysiological recordings from pairs of highly-overlapping A17 amacrine cells we assess the cross synaptic synchrony of the rod bipolar cell's output across a range of physiological conditions. We find that the output synapses of individual rod bipolar cells are near-perfectly synchronized in the dark, thus faithfully transmitting upstream signals and noise to all postsynaptic targets. Dim background lights desynchronize release, which causes a fundamental, but also reversible, change to the inputs to downstream circuit components.

Symposium

S3: The computational role of the hippocampus

- S3-1** A theory of hippocampal function, and how it incorporates spatial view cells in primates and place cells in rodents
Edmund Rolls
- S3-2** The CRISP theory of hippocampal function in episodic memory
Sen Cheng
- S3-3** Are memories really stored in the hippocampal CA3 region?
Torsten Neher, Sen Cheng, Laurenz Wiskott
- S3-4** Neural oscillations, behavior, and interaction within the hippocampal formations and between cortex and hippocampus
Francesco P. Battaglia
- S3-5** Sustained phase coupling of hippocampal single cell firing to network oscillations under epileptic conditions
Antje Kiliyas, Ulrich P. Friepe, Ute Häusler, Arvind Kumar, Carola A. Haas, Ulrich Egert
- S3-6** Neural mechanisms of spatial cognition
Neil Burgess

A theory of hippocampal function, and how it incorporates spatial view cells in primates and place cells in rodents

Edmund Rolls¹

¹Oxford Centre for Computational Neuroscience, Department of Computer Science, University of Warwick, CV4 7AL Coventry, United Kingdom

A quantitative computational theory of the operation of the hippocampus as an episodic memory system is described. The CA3 system operates as a single attractor or autoassociation network to enable rapid, one-trial, associations between any spatial location (place in rodents, or spatial view in primates) and an object or reward, and to provide for completion of the whole memory during recall from any part. The theory is extended to associations between time and object or reward to implement temporal order memory, also important in episodic memory. The dentate gyrus performs pattern separation by competitive learning to produce sparse representations, producing for example neurons with place-like fields from entorhinal cortex grid cells. The dentate granule cells produce by the very small number of mossy fiber connections to CA3 a randomizing pattern separation effect important during learning but not recall that separates out the patterns represented by CA3 firing to be very different from each other, which is optimal for an unstructured episodic memory system in which each memory must be kept distinct from other memories. The direct perforant path input to CA3 is quantitatively appropriate to provide the cue for recall in CA3, but not for learning. The CA1 recodes information from CA3 to set up associatively learned backprojections to neocortex to allow subsequent retrieval of information to neocortex, providing a quantitative account of the large number of hippocampo-neocortical and neocortical-neocortical backprojections. Tests of the theory including hippocampal subregion analyses and hippocampal NMDA receptor knockouts are described, and provide support for the theory.

Recordings from single hippocampal neurons in locomoting macaques reveal that some neurons are tuned to "spatial view". These hippocampal neurons (1) respond to a view of space "out there", not to the place where the monkey is; (2) have responses that depend on where the monkey is looking, as shown by measuring eye position; (3) can still occur (especially for CA1 neurons) if the view details are obscured with curtains; (4) that the cells (in e.g. CA1) retain part of their "space" tuning even in complete darkness, for several minutes; (5) that the spatial representation is allocentric; and (6) that the information about spatial view increases linearly with the number of cells in the representation. The spatial representation may be different from that of place cells in rats because of the smaller field of view of primates. It has also been shown that some hippocampal encode for objects, others for places in a room, and others for a combination of objects and places, while a monkey is performing an object-place memory task. This task is prototypical of episodic memory, and provides evidence that the primate hippocampus does associatively link information about objects and allocentric information about places "out-there".

Rolls,E.T. (2010) A computational theory of episodic memory formation in the hippocampus. *Behavioural Brain Research* 215: 180-196.

Rolls,E.T. (2008) *Memory, Attention, and Decision-Making*. Oxford University Press: Oxford.

Rolls,E.T. and Xiang,J -Z. (2006) Spatial view cells in the primate hippocampus, and memory recall.

The CRISP theory of hippocampal function in episodic memory

Sen Cheng¹

¹Ruhr University Bochum, Mercator Research Group "Structure of Memory", Universitätsstr. 150, 44801 Bochum, Germany

I will propose an alternative theory for the function of the hippocampus in episodic memory, which I believe to be more consistent with experimental evidence overall than the standard framework. The CRISP theory integrates many components that individually have been discussed previously, but never in a coherent framework. The crucial elements of our theory are Context Representation by the dentate gyrus (DG), Intrinsic Sequences in CA3 and Pattern completion in CA1. A distinguishing feature of CRISP is that associations are stored primarily in the feedforward network projections of the hippocampus, not in the recurrent CA3 synapses. Episodic memories of events are represented as sequences of neural activity. To store episodic memories, sequences of external stimuli are mapped onto intrinsic sequences in CA3, rather than imprinted into the plastic CA3 recurrent network. CA1 performs pattern completion and can therefore compensate for any distortions that were introduced in the recall of sequential elements in CA3. DG needs to override the CA3 intrinsic dynamics to initiate recall and to enable the storage of similar sequences. I will introduce the theory and discuss how this new theory can yield a more consistent interpretation of the major results in hippocampal research than the standard framework. If time permits, I will discuss some initial modeling results that argue in favor of the CRISP theory.

Are memories really stored in the hippocampal CA3 region?

Torsten Neher¹, Sen Cheng^{2,3}, Laurenz Wiskott^{1,2}

¹Institut für Neuroinformatik, Ruhr-Universität Bochum, Universitätsstr. 150, 44801 Bochum, Germany

²International Graduate School of Neuroscience, Ruhr University Bochum

³Mercator Research Group "Structure of Memory" and Faculty of Psychology, Ruhr-University Bochum, Universitätsstr. 150, D-44780 Bochum, Germany;

Undoubtedly, the hippocampus is crucial for memory formation: Patients with a lesioned hippocampus have profound deficits in acquiring new episodic memories (Milner et al., 1968). Furthermore, the hippocampus has a remarkable anatomical structure. It can be divided into the dentate gyrus with its huge number of small granule cells that show low activity (Leutgeb et al., 2007) and the areas CA3 and CA1 consisting of a homogeneous set of pyramidal cells, where in CA3 a striking number of neurons are recurrently connected. A further notable property is that the connection among the subregions is established largely in a feed forward manner (Amaral et al., 1990).

The question that arises is, how does this peculiar anatomical structure serve memory formation? We have developed a computational system model of the hippocampus that mimics its anatomy. A memory or episodic event is interpreted as a pattern of activation of a set of neurons in the entorhinal cortex, the hippocampal input structure. Once a memory is stored in the network, recall is modeled by presenting the network a recall cue, i.e. a corrupted or incomplete version of this memory and retrieval is considered successful, if the whole pattern could be reconstructed. In this framework it is now possible to investigate which storing mechanisms are the most effective ones and whether the special anatomy described above is essential for memory function.

In particular, we review the common idea that memories are mapped into CA3 and then stored in its recurrent fibers. It has been suggested that this region functions as an auto-association memory (Marr, 1971, Treves & Rolls, 1994, O'Reilly and McClelland, 1994, McNaughton and Morris, 1987). An auto-association memory is a recurrent network that stores patterns in its feedback connections and can reconstruct these patterns when only partial versions of them are presented. The recalled patterns are then transformed back into their original input versions via the CA1 region. Thus, the actual storing place are the recurrent fibers and this idea could explain why there are so many of them in CA3.

Our results indicate that CA3 as an auto-association memory can reconstruct previously stored patterns. This reconstruction, however, is also performed inevitably by transforming the patterns at later stages back into their original versions, which has not been considered so far. Thus, we argue that memories are already stored in the feed-forward connections from CA3 to CA1 while decoding is learned. Hence, additional storing in the CA3 network becomes redundant challenging the idea of CA3 functioning as an auto-association network.

Neural oscillations, behavior, and interaction within the hippocampal formations and between cortex and hippocampus

Francesco P. Battaglia¹

¹Radboud Universiteit Nijmegen, Donders Centre for Neuroscience, Heyendaalseweg 135 , 6525 AJ Nijmegen, Netherlands

Neural oscillations are a possible mechanism for the interaction between brain areas, and the concerted processing of information, I will briefly discuss two case studies, both centered on the hippocampus, revealing interactions between these dynamical processing, the creation of cell assemblies, and the expression of cognitive and behavioral functions.

1) Place coding in the hippocampus requires flexible combinations of sensory inputs with memory and self-motion information. We show that, depending on the behavioral strategy spontaneously selected by the animal on a complex ('star') maze, mouse CA1 hippocampal spatial representations may be anchored to external landmarks, or reflect memorized sequences of cell assemblies. These computational modalities correspond to profoundly different CA1 dynamical states, with changes in network oscillatory dynamics at theta, low-gamma, and high-gamma frequencies, consistent with a shift from entorhinal to CA3 input dominance on CA1 when switching from sensory-based to memory-based spatial processing. This shift is disrupted in mice with a deletion of NMDA receptors in CA1, paralleling impaired memory-based representations. We suggest that changes in oscillatory dynamics are key to the selection of behaviorally appropriate computations in the hippocampus, and that control of these regimes is a major function of NMDA receptors.

2) A complex brain network, centered on the hippocampus, supports episodic memories throughout their lifetimes. Classically, upon memory encoding during active behavior, hippocampal activity is dominated by theta oscillations. During inactivity, hippocampal neurons burst synchronously, constituting sharp waves, which can propagate to other structures, theoretically supporting memory consolidation. This 'two-stage' model has been updated by new data from high-density electrophysiological recordings in animals that shed light on how information is encoded and exchanged between hippocampus and the neocortex and subcortical structures.

Sustained phase coupling of hippocampal single cell firing to network oscillations under epileptic conditions

Antje Kiliyas¹, Ulrich P. Froriep^{1,2,3}, Ute Häusler⁴, Arvind Kumar^{2,3}, Carola A. Haas^{3,4},
Ulrich Egert^{1,3}

¹University of Freiburg, Department of Microsystems Engineering – IMTEK, Laboratory for Biomicrotechnology, Germany;

²Faculty of Biology, University of Freiburg, Germany;

³Bernstein Center Freiburg, University of Freiburg, Germany;

⁴Experimental Epilepsy Research, Department of Neurosurgery, Faculty of Medicine, University of Freiburg, Germany

Epileptic seizures in mesio-temporal lobe epilepsy (MTLE) are transient events. In contrast, histological changes in the hippocampal network associated with MTLE are persistent. How these changes contribute to generation of epileptiform activity (EA) might not be trackable during excessive epileptic discharges. We thus investigated activity free of epileptic events to identify modified properties of the network. “EA-free” activity contains the same typical network oscillations observable under healthy conditions such as theta and gamma rhythms.

Recently, the coupling within and across structures in theta and gamma frequency bands was found to be changed in a mouse model of MTLE. In particular, the theta rhythm was phase-shifted between the dentate gyrus (DG) and the medial entorhinal cortex (MEC) [1]. Furthermore, the local cross-frequency coupling between theta and gamma activities in the DG was inverted [2]. Mechanisms underlying those network effects on the cellular firing level are unknown.

Under healthy conditions, hippocampal neurons fire phase coupled with theta and gamma band local field potentials (LFPs), but it is unclear whether this spike phase coupling is preserved under epileptic conditions and further, whether phase shifted LFP are accompanied by shifted single cell activity.

In the present study we investigated the coupling of multi-unit activity (MUA) and LFP oscillations in the intrahippocampal kainic acid mouse model for MTLE. Therefore, we implanted multisite silicon probes into hippocampal and parahippocampal structures of epileptic and control animals. These custom made probes allowed simultaneous recordings of LFPs and MUA in freely behaving animals.

We found that in the whole hippocampal formation neurons fire phase coupled with respect to theta and gamma LFP rhythms under healthy as well as epileptic conditions. Remarkably, the theta phases at which cells fired in epileptic animals were comparable to those in healthy mice. Furthermore, the preferred coupling phases of neurons in the MEC and DG were independent of the distance to the injection site with the most prominent histological changes. Therefore, shifted LFP theta rhythms between hippocampus and MEC in MTLE imply a shift in single cell firing between both structures. This shifted firing might tune the network towards seizure susceptibility by pathological plasticity.

- [1] Froriep et al. Altered theta coupling between medial entorhinal cortex and dentate gyrus in temporal lobe epilepsy. *Epilepsia* (2012).
- [2] Froriep et al. Coupling changes across structures and frequencies in the hippocampus in epilepsy. *FENS Abstr.* (2012).

and 01GQ0830) and the Deutsche Forschungsgemeinschaft (SFB TR3 and SFB 780).

Neural mechanisms of spatial cognition

Neil Burgess¹

¹UCL, Inst Cognitive Neuroscience, 17 Queen Square, WC1N 3AR London, United Kingdom

Single unit recording in the hippocampal and entorhinal cortices of freely moving rodents provides detailed information regarding the neural representations of spatial context. I will describe some of these experiments and the computational mechanisms they imply, which emphasise the roles of environmental boundaries and of intrinsic temporal oscillations in the theta band. I will then describe the implications of these findings for the mechanisms supporting memory for spatial context, and provide examples of electrophysiological, behavioral, neuropsychological and functional neuroimaging experiments designed to test the resulting predictions.

Symposium

S4: Non-invasive brain stimulation: mechanisms, effects and opportunities

- S4-1** Physiological background of the effects of non-invasive brain stimulation
Michael A. Nitsche
- S4-2** Mechanisms of neuroprotection and neuroplasticity after Repetitive Transorbital Alternating Current Stimulation
Elena G. Sergeeva
- S4-3** Targeting of transcranial Direct Current Stimulation
Marom Bikson
- S4-4** Getting the right site, can navigation help us access non-primary motor areas: A sham-controlled serial navigated TMS study
Stephan A. Brandt, Sein Schmidt
- S4-5** Brain plasticity and connectivity in neurological diseases: the TMS contribution
Paolo Maria Rossini, Michela Ferilli
- S4-6** A Tool for the Simulation of the Electrical Activity of Realistic Neuron Morphologies in a Conductive Extracellular Space
Andres Agudelo-Toro, Andreas Neef
- S4-7** "Efficacy of non-invasive cortical stimulation: applications in neurorehabilitation and combination with training protocols"
Jorge Leon Morales-Quezada, Felipe Fregni

Physiological background of the effects of non-invasive brain stimulation

Michael A. Nitsche¹

¹University Medicine Goettingen, Dept. Clinical Neurophysiology, Robert-Koch-Str. 40, 37099 Goettingen, Germany

Reports about non-invasive electrical brain stimulation have been published sporadically since ancient times, however, systematic research on this topic exists only for about one or two decades (Nitsche and Paulus; 2000; Barker et al., 1985, Stefan et al. 2000). Since these seminal publications various techniques of non-invasive brain stimulation have increasingly gained attention as these methods allow exploring brain physiology including pathophysiological alterations and the physiological basis of cognitive processes directly in humans, and have obvious advantages for potential clinical applications (no surgery, relatively low costs). In most cases the stimulation protocols fall into 3 categories: transcranial direct current stimulation (tDCS), transcranial magnetic stimulation (TMS) and alternating current stimulation (tACS), the latter with a relatively active sub-field of repetitive transcorneal alternating current stimulation (RTACS). Having clear evidence of the efficacy of non-invasive brain stimulation, it is now of increasing interest to describe the underlying mechanisms. During the last years, knowledge about involved neuronal populations, and cortical networks has increased considerably due to electrophysiological, functional imaging, and pharmacological interventions. This enhances our ability to apply tailored stimulation protocols for hypothesis -driven alterations of brain functions in health and disease. An overview about the main physiological background of the above -emntioned stimulation techniques will be given, including affected neuronal populations, and transmitter systems, as well as systemic effects on cortical networks.

Mechanisms of neuroprotection and neuroplasticity after Repetitive Transorbital Alternating Current Stimulation

Elena G. Sergeeva¹

Otto-von-Guericke University of Magdeburg, Institute of Medical Psychology, Leipziger Strasse 44, 39120 Magdeburg, Germany

Current stimulation is emerging as a new tool to manipulate central nervous system plasticity and restoration. Most recently, we have induced recovery of vision by applying non-invasive repetitive transorbital alternating current stimulation to patients with optic nerve damage. It was proposed that visual field improvements were mediated by increased neuronal synchronization of residual visual system structures and higher cortical areas.

For a better understanding of the mechanisms of action of current stimulation experiments in animals are required. In preclinical studies using animal models it was revealed that transcorneal alternating current stimulation (tACS) decreases acute death of retinal ganglion cells (RGCs) after optic nerve transection in rats, but it is not known if cell survival is long-term and associated with functional restoration. We therefore evaluated the effects of tACS in a rat model of optic nerve crush (ONC) based on anatomical, electrophysiological and behavioural measures to clarify the potential domain(s) where the stimulation has an effect and to further understand possible prerequisites of functional restoration.

Our results suggest that tACS induced long-term neuronal protection specifically from delayed retrograde cell death after severe axonal damage but did not improve visual performance in a behavioural test. Also it was not associated with changes in bioelectrical activity (EEG, VEP – visual evoked potentials), recorded from visual cortex. However, we demonstrated that tACS can induce neuroplasticity in rodents under certain circumstances, as shown by EEG “after-effects” that outlast the stimulation period. But this “after-effects” are not seen when tACS is applied during deep anaesthesia and not when applied to animals after severe optic nerve damage. We conclude that tACS requires a minimal level of brain activation and is only effective to induce cortical plasticity when the retina can be excited.

To avoid this problem of low functional state of brain under narcosis, we set up a new preclinical tACS model with unanaesthetized, freely-moving rats. The animals are stimulated via fine wire electrodes implanted under the upper eyelid, and field potentials are recorded from visual cortex and superior colliculus.

This technique enables us to find electrophysiological correlates of tACS and report for the first time electrically evoked responses (EERs) by tACS in visual cortex of freely-moving animals. Evaluation of amplitudes and latencies of components can reveal the EER origin, particularly when comparing the EER with VEP. Thereby, it will be possible to identify the target site for tACS treatment and clarify optimal parameter settings for tACS to achieve maximal visual responses.

With our experiments in rodents we like to further understand tACS and based on this to optimise the treatment. Our results suggest that tACS acts via different mechanisms (neuroprotection as well as neuroplasticity) and on different target structures (from retina to visual cortex).

Targeting of transcranial Direct Current Stimulation

Marom Bikson¹

¹The City College of New York, Department of Biomedical Engineering, 160 Convent Ave, Room T-403B, 11238 New York, USA

Transcranial direct current stimulation (tDCS) is a neuromodulatory technique that delivers low-intensity currents facilitating or inhibiting spontaneous neuronal activity. tDCS is attractive since dose is readily adjustable by simply changing electrode number, position, size, shape, and current. In the recent past, computational models have been developed with increased precision with the goal to help customize tDCS dose. The aim of this talk is to discuss the incorporation of high-resolution patient-specific computer modeling to guide and optimize tDCS including (i) The clinical motivation and rationale for models of transcranial stimulation is considered pivotal in order to leverage the flexibility of neuromodulation; (ii) The protocols and the workflow for developing high-resolution models; (iii) The technical challenges and limitations of interpreting modeling predictions, and (iv) Real cases merging modeling and clinical data illustrating the impact of computational models on the rational design of rehabilitative electrotherapy. Though modeling for non-invasive brain stimulation is still in its development phase, it is predicted that with increased validation, dissemination, simplification and democratization of modeling tools, computational forward models of neuromodulation will become useful tools to guide the optimization of clinical electrotherapy.

Getting the right site, can navigation help us access non-primary motor areas: A sham-controlled serial navigated TMS study

Stephan A. Brandt¹, Sein Schmidt¹

¹Charité, Dept. Neurology, Charitéplatz 1, 10117 Berlin, Germany

Background: Premotor cortical regions (PMC) play an important role in the orchestration of motor function. Direct modification of premotor functions with non-invasive brain stimulation has contributed to our understanding of the effect that PMC modification has on the primary motor cortex (M1). Animal studies and studies on stroke patients have shown how an M1 lesion affects the PMC. Here we investigate with non-invasive brain stimulation the effect that M1 modification has on the electrophysiological properties of the PMC, as well as consequences for motor performance.

Purpose: To determine if PMC neural activity changes to compensate for attenuated M1 excitability and finger-tapping speed.

Hypothesis: Cathodal transcranial direct current (tDCS) inhibition of M1 will lead to a secondary increase in ipsilateral PMC excitability.

Methods: We enrolled 16 healthy participants for this randomized, double-blind, sham-controlled, crossover design study. All participants underwent navigated transcranial magnetic stimulation (nTMS) to identify PMC and M1 as well as to evaluate electrophysiological measures of cortical, intracortical and interhemispheric excitability. Cortical M1 excitability was inhibited using cathodal tDCS. Finger-tapping speeds were used to examine motor function.

Results: Cathodal tDCS successfully reduced M1 excitability and motor performance speed. PMC excitability increase lasted longer and was the only significant predictor of motor performance.

Conclusion: PMC compensates for attenuated M1 excitability and contributes to motor performance maintenance.

Brain plasticity and connectivity in neurological diseases: the TMS contribution

Paolo Maria Rossini¹, Michela Ferilli²

^{1,2}Catholic University of The Sacred Heart, Institute of Neurology, Largo Gemelli 8, 00168 Rome, Italy

Transcranial magnetic stimulation (TMS) is a 20-year-old technique introduced for the first time to noninvasively investigate nervous propagation along the corticospinal tract, spinal roots, and peripheral nerves in humans.

TMS can be used to analyze the functional state of the cerebral cortex, discovering changes in its excitability, connectivity and plasticity which may have occurred through processes such as learning or recovery from a lesion.

Depending on stimulation parameters, TMS (particularly repetitive TMS) can transiently disrupt or facilitate activity in a brain region participating to a functional network, providing an important tool for the study of motor and sensory processes, attention, memory, language, and neuronal plasticity .

Plasticity is the mechanism for development and learning, but at the same time can represent a cause of dysfunction. Plasticity is an intrinsic property of the human brain. It is the evolution's instrument to enable the nervous system to escape the restrictions of its own genome and therefore adapt to environmental pressures, physiologic changes, and experiences. It has been broadly studied in the last decades because it is considered the mechanism underlying several cognitive processes, and also because of its potential therapeutic applications in neuropsychiatric disorders. Most of the studies about neural plasticity concentrate on functional plasticity and Hebbian-like long-term potentiation (LTP) and depression (LTD), which considers synapses and synaptic strengths as variable amplification factors within a hardwired network structure.

TMS may affect the synaptic LTP and LTD by modulating neurotransmitter availability and postsynaptic receptor density in cortical neurons, directly underlying the stimulus, and also among those connected to them. TMS is a non-invasive tool which has been used to analyze the brain plasticity changes which result from stroke and as a therapeutic method to improve motor function without risks. Many evidences bring to the possibility that TMS induces an exogenous plastic rearrangement of synaptic efficacy in the stimulated network. Most evidence comes from studies on sensorimotor areas, but the principles can be suited to networks subserving cognition, emotion and mood regulation.

The structural plasticity concept is connected to the concept of anatomical brain connectivity. Anatomical connectivity relates in fact to a network of synaptic connections linking both sets of neurons or neuronal elements and their associated structural biophysical attributes encapsulated in parameters that include synaptic strength or effectiveness.

Recently TMS-EEG studies have begun to describe the nature of the TMS- evoked EEG responses in order to broaden the comprehension of the activation mechanisms of TMS.

Several studies have proved the power of TMS-EEG by displaying many data about the excitability or connectivity of the brain. Particularly, it has been proposed that the very first part of the TMS evoked EEG response displays the excitability – that means the functional state - of the stimulated cortex while its spatio-temporal distribution over the scalp displays the spread of activation to other cortical areas - via intra and inter-hemispheric cortico-cortical connections as well as to sub-cortical structures and spinal cord via projection fibres- reflecting the effective connectivity of the stimulated area.

Finally effective connectivity - a concept interesting in the EEG-TMS co-registration field - may be considered as the fusion of structural and functional connectivity, as it describes networks of directional effects of one neural element over another.

A Tool for the Simulation of the Electrical Activity of Realistic Neuron Morphologies in a Conductive Extracellular Space

Andres Agudelo-Toro¹, Andreas Neef^{1,2,3}

¹Max Plack Institute for Dynamics and Self-organization, Non linear dynamics, Am Faßberg 17, 37077 Göttingen, Germany

²Bernstein Focus Neurotechnology Göttingen, Germany

³University Medicine Göttingen, Germany

Externally applied electric fields and fields produced by cellular activity alter the function of neurons. Recent findings show that endogenous fields act back onto the neurons, contributing to synchronization of population activity. Externally produced fields are used in therapeutic approaches such as transcranial direct current stimulation, transcranial magnetic stimulation and deep brain stimulation. The mutual interaction between these fields and membrane currents is not captured by today's modeling tools of neuronal electrophysiology, as those are based on isolated membranes in an infinite, isopotential extracellular space. Still neurons live in a dense packing of cells where heterogeneities are common. While a reduced set of Maxwell's equations can be used to couple membrane currents to extra- and intracellular potentials, this approach is rarely taken, most likely because adequate computational tools are missing. We present a numerical tool that implements this set of equations. The tool was constructed as an open source software package which is now freely available to the community. It allows simulation of cells under realistic conditions: a conductive, non-homogeneous space, sub-micron cell morphology, mixed boundary conditions and various ion channel properties and distributions. The extracellular fields are accurately represented, including secondary fields, which originate at inhomogeneities of the extracellular space and can reach several millivolts. Example applications of this tool are presented.

FIGURE: Simulation with the tool of the potentials in and around a neuron on a dish firing action potentials (AP). (A) The morphology of the simulated neuron is derived from an actual reconstruction. Color/grayscale indicate the membrane potential and extracellular potential at the bottom of the dish in a snapshot just after initiation of the AP ($t=4.72\text{ms}$, vertical line in B-D, $dt=40\mu\text{s}$). The cell was stimulated by injection of 100pA into the soma beginning at $t=0.3\text{ms}$. The AP started in the axon initial segment ($20\mu\text{m}$ away from the soma) which has a higher concentration of sodium and potassium channels. (B) Time trace of an intracellular recording with a "virtual pipette" located at the end of the axon hillock (marked as B in the main panel). (C) Time trace of the extracellular potential just outside the axon hillock. (D) Extracellular potential as it would have been picked up by a surface electrode to the left of the soma (gray circle, marked as D). (E) Extracellular potential along the line between markers D and C ($t=4.72\text{ms}$). (F) 100ms of activity during current injection (84ms , same parameters). This computation took 6 hours and 27 minutes with a time-step of $100\mu\text{s}$.

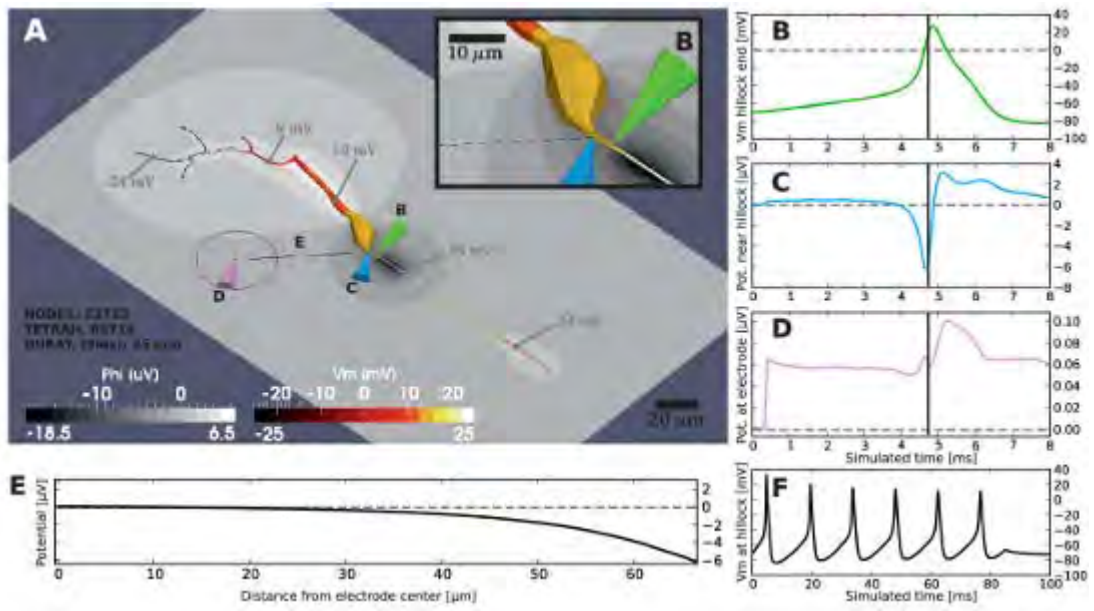

"Efficacy of non-invasive cortical stimulation: applications in neurorehabilitation and combination with training protocols"

Jorge Leon Morales-Quezada^{1,2}, Felipe Fregni¹

¹Neuromodulation laboratory, Spaulding Rehabilitation Hospital, Harvard Medical School. Boston, MA. USA.

²Health and Life Sciences, De Montfort University. Leicester, UK.

Brain stimulation applied in the field of neurorehabilitation has been used in the last 20 years. Although its development has been steady, current advances in the techniques of brain stimulation have improved its clinical efficacy. The use of non-invasive brain stimulation has significant advantages, such as not involving surgical procedures and having relatively mild adverse effects. Two of these techniques are; repetitive transcranial magnetic stimulation (rTMS) and transcranial direct current stimulation (tDCS), which can be considered as therapeutic approach in physical and rehabilitation medicine. rTMS and tDCS might have an important therapeutic value in different neurological and physical conditions.

Therapies for neurological rehabilitation still are not satisfactory. To date the best approach seems to be the intensive physical therapy. However the results are limited and functional gains are often minimal. The goal of neuro-cognitive training is to minimize functional and cognitive disability and optimize recovery. This is thought to be achieved by modulation of plastic changes in the brain. Therefore, adjunct interventions that can augment the response of the motor and sensory systems to the behavioral training might be useful to enhance the therapy-induced recovery in neurological populations. In this context, noninvasive brain stimulation appears to be an interesting option as an add-on intervention to standard physical therapies. Two non-invasive methods of inducing electrical currents into the brain have proved to be promising for inducing long-lasting plastic changes in motor systems: transcranial magnetic stimulation (TMS) and transcranial direct current stimulation (tDCS). These techniques represent powerful methods for priming cortical excitability for a subsequent motor task, demand, or stimulation. Thus, their mutual use can optimize the plastic changes induced by motor practice, or cognitive enhancements leading to more remarkable and outlasting clinical gains in rehabilitation. In this review we will discuss how these techniques can enhance the effects of a behavioral intervention and the clinical evidence to date.

Symposium

S5: "The paradox of the critical period" – rejuvenating cortical networks

- S5-1** Development of orientation and direction selectivity in mouse visual cortex neurons in vivo
Nathalie Rochefort
- S5-2** Critical Period Plasticity and Binocular Matching in the visual cortex
Jianhua Cang
- S5-3** Active self-organization of a disordered arrangement of orientation preference in the visual cortex
Juan Daniel Flórez Weidinger , Wolfgang Keil, Dmitry Tsigankov, Michael Schnabel, Matthias Kaschube, Fred Wolf
- S5-4** Action video games as exemplary learning tools.
Daphne Bavelier
- S5-5** Molecular control of ocular dominance plasticity
Tommaso Pizzorusso, Paola Tognini, Raffaele Mazziotti, Debora Napoli, Elena Putignano, Elena M Boggio, Davide Silingardi
- S5-6** NARP-dependent recruitment of inhibition reversibly regulates the critical period for ocular dominance plasticity
Elizabeth Mary Quinlan
- S5-7** Environmental enrichment extends ocular dominance plasticity in mouse visual cortex into adulthood and protects from stroke-induced reductions of plasticity
Franziska Greifzu, Katja Krempler, Justyna Pielecka-Fortuna, Siegrid Löwel

Development of orientation and direction selectivity in mouse visual cortex neurons in vivo

Nathalie Rochefort¹

¹TUM, Institut for Neuroscience, Biedersteiner strasse 29, 80802 Munich, Germany

Throughout the visual system of vertebrates, neurons are tuned to respond to different features of a visual scene such as the position or the orientation of a given object. I have used the method of in vivo two-photon calcium imaging to study the development of spontaneous and evoked activity in the mouse primary visual cortex. In this talk, I will show two applications of this method, both at the level of neuronal populations and of individual dendrites and spines.

In the first study, I will address a vigorously debated question in sensory system physiology: how do neurons in the primary visual cortex acquire their functional properties? The results have shown that before eye-opening, the spontaneous activity of layer 2/3 neurons consisted of slow wave oscillations with a large fraction of neurons being synchronously active. One day after eye-opening, this dense mode of recruitment changes to a sparse mode. Interestingly, this switch in spontaneous network activity correlated with the emergence of neuronal functional selectivity. Neurons selective for the orientation of drifting gratings were detected just after eye opening and nearly all of them were also highly tuned for the direction of stimulus motion. Later on, the number of neurons responding to drifting gratings increased in parallel with the fraction of neurons that were orientation, but not direction, selective. These results revealed surprising insights that are in sharp contrast to the results previously obtained in the ferret. In addition, this study offers a new model system for understanding how direction selectivity arises in a manner independent of visual experience.

In parallel to the study of layer 2/3 neuron selectivity, I have investigated the relationship between the inputs that these neurons receive at the level of their dendrites and the specific output firing pattern. An intriguing open question is whether sensory inputs with similar features are clustered on the same dendrite of a neuron or dispersed throughout the dendritic tree. I have worked on a novel approach for the visualization and functional mapping of sensory inputs to the dendrites of cortical neurons in vivo. Previous work has identified visually-evoked local dendritic calcium signals ('hot spots'; Jia, Rochefort et al., Nature, 2010) in the mouse visual cortex. However, visually-evoked signaling on the level of dendritic spines, corresponding to individual afferent excitatory synapses, remained unexplored. To analyze spine signaling during spontaneous and visually-evoked activity in vivo, layer 2/3 pyramidal neurons were first electroporated with a calcium dye and then targeted for cell-attached recordings. By using the 'low power temporal overSampling (LOTOS)' variant of two photon microscopy that was recently shown to facilitate single spine imaging in vivo (Chen et al., Nature, 2011), single spine calcium signals were recorded in parallel with the somatic spiking activity. Importantly, distinct single spine calcium signals could be identified in response to visual stimulation. Such active spines were widely distributed on basal and apical dendrites and drifting grating stimulation revealed both narrowly and widely tuned spines for the orientation and the direction of the gratings. These results provide strong support to the notion that the previously identified 'hot spots' represent single spine synaptic inputs.

Critical Period Plasticity and Binocular Matching in the visual cortex

Jianhua Cang¹

¹Northwestern University, Neurobiology, 2205 Tech Drive, Hogan 2-160, 60208 Evanston, USA

Critical periods are restricted time windows in postnatal development when sensory and motor experiences shape neural circuits in the brain. Recent studies in mice have started to reveal the genetic and epigenetic mechanisms that control the opening and closure of the critical periods. However, the functional significance of the proper timing of the critical period in normal development still remains unclear. We addressed this issue in the visual system, where critical period plasticity has been extensively studied in the form of ocular dominance (OD) plasticity. We previously discovered that normal vision during this critical period drives the binocular matching of orientation preference in the mouse primary visual cortex (Wang, Sarnaik, and Cang, 2010). In this study, we examined binocular matching in mice that have precocious OD plasticity due to the overexpression of brain-derived neurotrophic factor (BDNF-OE, Huang et al, 1999). Surprisingly, the orientation preference of individual cortical neurons is binocularly mismatched in the BDNF-OE mice. The disruption in binocular matching is specific to complex cells, but not simple cells, and such a deficit is completely phenocopied by treating wild type (WT) mice pharmacologically to enhance inhibition maturation. With simple and complex cells representing successive stages in visual information processing, we further examined the time course of their binocular matching in WT mice. Simple cells are found to match before complex cells, suggesting that the matching deficits in the transgenic and pharmacologically -treated mice may result from the precocious closure of critical period plasticity before the normal matching in complex cells. We further show that environmental enrichment completely rescues the deficit by shifting the matching process to coincide with the precocious plasticity. Together, our experiments indicate that a properly-timed critical period is required for establishing normal binocularity and its genetic misregulation can be rescued by environmental enrichment during development.

Active self-organization of a disordered arrangement of orientation preference in the visual cortex

Juan Daniel Flórez Weidinger¹, Wolfgang Keil^{1,2}, Dmitry Tsigankov⁵, Michael Schnabel⁴, Matthias Kaschube⁵, Fred Wolf^{1,2,3}

¹Max Planck Institute for Dynamics and Self - Organization , Nonlinear Dynamics , Göttingen , Germany

²Bernstein Center for Computational Neuroscience, Göttingen , Germany

³Georg August Universität Göttingen , Germany

⁴ Engineering Sciences and Applied Mathematics, Northwestern University, Evanston, IL, USA.

⁴Goethe-Universität Frankfurt am Main, Germany

Response characteristics of orientation tuned neurons in the visual cortex appear to be similar in mammalian lineages widely separated in evolution. The spatial arrangements of tuning properties across the cortex, however, show fundamental differences. While in primates and carnivores orientation preference varies progressively forming orientation maps, in rodents it appears to be randomly distributed. The developmental processes and evolutionary origins of these two opposite layout-types remain enigmatic. Previous research in our group showed that columnar orientation maps realize a common design, where layout statistics like pinwheel density and pinwheel nearest neighbour distance are conserved even in different species widely separated in evolution. This common design naturally emerges by activity-dependent self-organization of large scale neuronal circuits when orientation selective long range interactions are present (Kaschube et al., Science 2010). Here we show that cortical circuit self-organization can also explain the rodent layout type. We construct a model where neurons interact in a distance dependent manner both with isotropically and with orientation selective inhibition and excitation. By symmetry this model has a large set of exact map solutions. Analytically examining their stability, we find that, independent of the fraction of selective interactions, when local circuits are predominantly suppressive all map solutions are unstable and an interspersed organization is actively generated. Numerical simulations show that the final arrangement of orientations is not random, showing a weak negative correlation between nearest neighbours and an increased homogeneity. Because of the high amount of similar disordered solutions the energy barriers between them seem shallow, making the system suffer from a substantial dynamical lability of neuronal selectivities compared to columnar architectures. A recent report indicates that the orientation preference in the two eyes are matched after the initially independent development of orientation selectivity in each eye (Wang et al., Neuron 2010). Therefore, we examine generalizations of the model to two eyes and identify a parameter regime in which the eyes are only matched after the emergence of selectivity. The interspersed structure is preserved while the difference in response to inputs between the eyes is dynamically decreased. Finally, using a stimulus-driven model with dynamics based on neural learning of visual stimulus representations we show that, although neurons tend to coactivate by stimulation, with predominantly suppressive interactions the final arrangement of orientation selectivities is disordered. The final layouts in general exhibit superior stimulus coverage than organized maps, giving them an advantage when a large set of stimuli has to be represented in a small space. Our results indicate, that the apparently random arrangement of orientation selectivity in rodents might be the result of a dynamical activity-dependent process. If so, the spatial distribution of orientation preferences is expected to exhibit more spatial structure than previously thought.

Action video games as exemplary learning tools.

Daphne Bavelier¹

¹U. of Geneva, Cognitive Neuroscience - FPSE, 40 bd du Pont d'Arve, CH-1205 Geneva, Switzerland

In a surprising twist, an often-decried activity such as playing action video games enhances various sensory, attentional and cognitive skills. A training regimen whose benefits are so broad is unprecedented and provides a unique opportunity to identify factors that underlie generalization of learning and principles of brain plasticity. A set of common mechanisms are hypothesized to be at the source of this wide range of skill improvement. In particular, performance improvement following action video game play may be mediated through greater attentional control, better statistic inference in neural networks and in turn an enhanced ability at learning to learn. Practical applications from education to rehabilitation will be discussed.

Molecular control of ocular dominance plasticity

Tommaso Pizzorusso¹, Paola Tognini¹, Raffaele Mazziotti¹, Debora Napoli¹, Elena Putignano¹, Elena M Boggio¹, Davide Silingardi¹

¹CNR, Inst Neuroscience, via Moruzzi, 1, 56124 Pisa, Italy

The visual cortex represents a classical model for studies on experience-dependent plasticity of cortical circuit development. Visual cortical plasticity is often evoked by manipulation of visual input such as visual deprivation. The effects of these perturbations are stronger during windows of development designated critical or sensitive periods. In this talk, we will report recent work showing how different molecular mechanisms can be targeted to enhance plasticity in adult animals after sensitive period closure.

NARP-dependent recruitment of inhibition reversibly regulates the critical period for ocular dominance plasticity

Elizabeth Mary Quinlan¹

University of Maryland, Biology, 1110 Biosciences Research Building, 21403 College Park, Maryland, USA

The regulation of the critical period for ocular dominance plasticity is widely believed to be dependent on the strength of inhibitory synapses targeting the somata of principal neurons in the visual cortex. Perisomatic inhibition exert powerful control of neuronal spiking output in principal neurons, thereby regulating the activity-dependent synaptic plasticity that allows discrimination between input from the two eyes. In support of this model, manipulations that trigger a precocious development of perisomatic inhibition activate an early critical period for ocular dominance plasticity. However, ocular dominance plasticity persists in the rodent visual system long after perisomatic inhibition reaches full maturation. Importantly, enhancing inhibitory output with diazepam inhibits late ocular dominance plasticity.

We hypothesized that the ability to recruit inhibitory circuitry may be a key step in the regulation of the critical period for ocular dominance plasticity. We tested this hypothesis by examining the recruitment of inhibition mediated by FS (PV) INs, which mediate the majority of perisomatic inhibition. We characterized excitatory inputs onto interneurons in the visual cortex in mice lacking the gene for NARP (neuronal activity-regulated pentraxin a.k.a. NP2), an AMPAR binding protein that is specifically enriched at excitatory synapses onto fast-spiking parvalbumin-positive interneurons (FS (PV) INs). NARP ^{-/-} mice have a reduction in the number of excitatory synaptic inputs onto FS (PV) INs, resulting in a reduction in excitatory drive. The absence of NARP renders the visual cortex hyper-excitable, and unable to express ocular dominance plasticity, while other aspects of circuit function are unimpaired. Importantly, inhibitory output from FS (PV) INs onto principle neurons in the visual cortex is normal in NARP ^{-/-} mice, and enhancement of this output enables the expression of ocular dominance plasticity.

We propose that NARP-dependent recruitment of rapid inhibition from FS (PV) INs ensures the precision of pyramidal cell activity necessary to engage synaptic plasticity. Indeed, dark exposure does not reactivate ocular dominance plasticity in NARP ^{-/-} mice. The NARP-dependent enhancement of excitatory drive onto FS (PV) INs is therefore an important locus for the bidirectional regulation of ocular dominance plasticity.

Environmental enrichment extends ocular dominance plasticity in mouse visual cortex into adulthood and protects from stroke-induced reductions of plasticity

Franziska Greifzu¹, Katja Krempler², Justyna Pielecka-Fortuna¹, Siegrid Löwel¹

¹Systems Neuroscience, Bernstein Fokus Neurotechnologie, J.F.Blumenbach-Institut für Zoologie und Anthropologie, Georg-August-Universität Göttingen, Von-Sieboldstr. 4, D-37075 Göttingen, Germany

² Hans Berger Klinik für Neurologie, Universitätsklinikum Jena, Erlanger Allee 101, D-07747 Jena, Germany

Ocular dominance (OD) plasticity in the visual cortex is maximal at 4 weeks of age in mice, declines in 2-3 months old animals and is absent beyond postnatal day (PD) 110 if animals are raised in standard cages (SC; Lehmann & Löwel, 2008, PLoS ONE). Since environmental enrichment (EE) has been shown to promote plasticity in adult rats (e.g. Sale et al., 2007, Nat Neurosci) we wondered whether raising mice in EE would prolong the sensitive phase for OD-plasticity. We therefore raised mice from before birth into adulthood (>PD 110) in EE and visualized OD-plasticity by intrinsic signal optical imaging. EE not only preserved OD-plasticity but created adult animals with juvenile-like plasticity: 7 days of MD in 119-196 days old EE -mice induced both a very strong OD- shift and significantly decreased deprived eye responses while SC-mice of the same age did not express OD-plasticity. Diazepam administration during MD reduced but did not completely abolish OD- plasticity in adult EE -mice, indicating that the rejuvenating effect of EE was only partially mediated by reduced inhibition. EE also restored already lost plasticity: when mice raised in a SC were transferred to EE starting at PD 110 (late EE), an age in which OD-plasticity is no longer present in SC-mice, OD-plasticity was restored after 3-7 months. Late-EE mice thus showed OD-plasticity even up to PD 320. EE therefore not only extended the critical period for mouse OD-plasticity into late adulthood but also “rejuvenated” the visual cortex. To test whether EE might be used therapeutically to “treat” the compromised plasticity after a photothrombotically (PT) induced stroke in the somatosensory cortex (Greifzu et al., 2011, PNAS; Greifzu et al., 2012, e-Neuroforum) we again raised mice in EE and then exposed them to a stroke. Indeed, in adult EE-mice, OD-plasticity was present even after stroke. Finally, if the major effect of EE is to preserve a “younger” brain into adulthood, and if a younger brain is less susceptible to stroke-induced impairments of cortical plasticity then OD-plasticity after stroke should also be preserved in young mice. This was indeed the case: PD 28-35 mice retained OD-plasticity even if they had the same PT-lesion as the adult animals. Taken together, EE from before birth preserved a juvenile-like OD-plasticity into adulthood, rejuvenated the brain even after nearly 4 months of standard cage rearing and protected adult mice from stroke-induced impairments of cortical plasticity. Funding by the BMBF (1GQ0921) is gratefully acknowledged.

Symposium

S6: Mouse models in hearing research: unraveling auditory processing from molecules to behavior

- S6-1** The sound of silence: defects in hair cell mechanotransduction that cause deafness
Ulrich Mueller
- S6-2** Effects of otoferlin mutations on hearing function
Nicola Strenzke, Elisabeth Auge, Hanan Al-Moyed, Tina Pangrsic, Tobias Moser, Ellen Reisinger
- S6-3** The role of the presynaptic scaffold protein Bassoon in synaptic transmission at the mouse endbulb of Held.
Alejandro Mendoza Schulz, Zhizi Jing, Juan María Sanchez Caro, Nicola Strenzke, Carolin Wichmann, Tobias Moser
- S6-4** Sound coding through feedback crosstalk between the peripheral and central auditory system: Learning from conditional mouse models
Marlies Knipper, Cze Chim Lee, Annalisa Zuccotti, Thomas Schimmang, Wibke Singer, Lukas Rüttiger
- S6-5** Optogenetic manipulation of neuronal activity patterns in the mouse auditory cortex in the context of a go/nogo task.
Juliane Tinter, Bruno de Palma Pedrosa Fontinha, Brice Bathellier, Simon Rumpel
- S6-6** Distorted hearing in mice lacking the $\alpha_2\delta_3$ Ca^{2+} channel subunit – a model for an auditory processing disorder
Jutta Engel, Antonella Pirone, Simone Kurt

The sound of silence: defects in hair cell mechanotransduction that cause deafness

Ulrich Mueller¹

¹The Scripps Research Institute, Dorris Neuroscience Center, 10550 N. Torrey Pines Rd, 92037 La Jolla, USA

Hair cells are mechanosensors for the perception of sound, acceleration and fluid motion. Mechanotransduction channels in hair cells are gated by tip links, which connect the stereocilia of hair cells in the direction of their mechanical sensitivity. Despite decades of study, we have a very limited knowledge of the molecular constituents of the hair cells mechanotransduction machinery. To identify such components, we have carried out forward and reverse genetic screens to generate mouse lines with recessive forms of deafness. Many of the mutant mouse lines have defects in the development and/or function of the mechanically sensitive stereocilia and their mechanotransduction apparatus. Through SNP mapping and exom sequencing, we have identified nearly two dozen gene mutations that cause deafness. More than 90% of the affected genes are expressed within the inner ear specifically in hair cells. Remarkably, all of the affected genes are also linked to deafness in humans. Our subsequent functional studies have shown that several of the affected genes encode components of the mechanotransduction machinery of hair cells, including components of tip links, their associated molecules, and a subunit of the mechanotransduction channel. We will discuss our findings on the identification, structure and function of these molecules, as well as the molecular pathogenesis that is caused by defects in their function.

Effects of otoferlin mutations on hearing function

Nicola Strenzke¹, Elisabeth Auge¹, Hanan Al-Moyed¹, Tina Pangrsic¹, Tobias Moser¹,
Ellen Reisinger¹

¹University of Göttingen Medical School, InnerEarLab, Dept. of Otolaryngology, Robert-Koch-Str. 40, 37075 Göttingen, Germany

The lack of otoferlin as a consequence of homozygous mutations in the OTOF gene leads to profound prelingual deafness DFNB9. However, a minority of human DFNB9 patients have residual hearing capacity, displaying an auditory synaptopathy phenotype with deficits in the temporal precision of auditory encoding, including poor speech discrimination.

Electrophysiological studies using a knockout mouse demonstrated that otoferlin is required for calcium-induced exocytosis from inner hair cells (Roux et al. 2006). While otoferlin knockout mice are profoundly deaf, we observed some activity-dependent sound-evoked auditory nerve fiber spiking in two strains of mice with point mutations in the *Otof* gene. In both mutant mouse lines, otoferlin protein levels in inner hair cells were reduced. These animal models allow us to study in depth the consequences of a synaptic dysfunction from the cell physiological level up to auditory systems responses and behavior. We have analyzed how a deficit in sustained exocytosis impacts auditory nerve spike rates. Our findings suggest a role for otoferlin in vesicle replenishment at the inner hair cell ribbon synapse. The defective replenishment results in a strong reduction in auditory brainstem responses and impaired gap detection in psychophysical tasks.

The role of the presynaptic scaffold protein Bassoon in synaptic transmission at the mouse endbulb of Held.

Alejandro Mendoza Schulz¹, Zhizi Jing², Juan María Sanchez Caro¹, Nicola Strenzke²,
Carolin Wichmann³, Tobias Moser^{1,4}

¹InnerEarLab, Dept. of Otolaryngology and Center for Molecular Physiology of the Brain, University Göttingen Medical Center, Germany;

²InnerEarLab, Auditory Systems Physiology Group, Dept. of Otolaryngology and SFB889, University Göttingen Medical Center, Germany;

³InnerEarLab, Molecular architecture of synapses Group, Dept. of Otolaryngology and SFB889, University Göttingen Medical Center, Germany;

⁴Bernstein Center for Computational Neuroscience and SFB889, Göttingen, Germany;

Endbulbs of Held are the large calyceal presynaptic terminals of auditory nerve fibers onto bushy cells in the anteroventral cochlear nucleus. These synapses transmit precisely timed auditory signals up to high frequencies that provide the basis for downstream computation of sound localization and for speech perception (Oertel, 1997, 2005). The molecular mechanisms enabling their signaling at hundreds per second are largely unknown. Here we report about functional and structural changes upon genetic disruption of Bassoon, a large presynaptic scaffold protein in the cytomatrix of the active zone by studying the partial deletion mutant BSN^{ΔEx4/5} (Altrock et al., 2003). Active zones are normal in number, but the postsynaptic densities (PSDs) are enlarged and the vesicle number in close proximity to the presynaptic plasma membrane per μm PSD is reduced. In *in-vitro* slice electrophysiological experiments miniature EPSCs exhibit a larger amplitude and trend towards occurring less often. By applying a minimal stimulation technique we find that the shape and amplitude of evoked EPSCs recorded from bushy cells are largely unaltered. Short-term depression in response to train stimulation is increased in the mutant; most pronounced at 100 Hz compared to 200 Hz and 333 Hz. This and a reduced rate of recovery after short-term depression suggest that the rate of vesicle replenishment is compromised in the absence of full-length Bassoon. The size of the readily releasable pool of vesicles is reduced and release probability is increased as estimated with the method of cumulative EPSCs (Schneppenburger et al., 1999). In consequence, delayed/asynchronous release is increased in the mutant synapses during and after train stimulation. Even though synaptic depression is significantly stronger in mutant synapses, bushy cells compensate for the loss of input and fire with comparable reliability during high frequency stimulation. Also *in-vivo*, primary -like responses generated by bushy cells in the anteroventral cochlear nucleus transmit with high reliability, even though spontaneous and evoked rates are reduced in the auditory nerve. It was reported earlier that auditory brain stem responses from Bassoon mutants show synchronous activity from globular bushy cells (wave 2 was almost normal) despite almost complete lack of synchronous activity in the auditory nerve. Now, we provide evidence that this is due to homeostatic plasticity in bushy cell encompassing increasing intrinsic excitability and synaptic upscaling. This manifests itself in increased mEPSCs and an enhanced response to depolarizing current injection in mutant bushy cells.

Together, our data suggest that Bassoon promotes vesicle replenishment and a large readily releasable pool, and that the cochlear nucleus maintains reliability of transmission in a homeostatic fashion in response to partial deafferentation.

Sound coding through feedback crosstalk between the peripheral and central auditory system: Learning from conditional mouse models

Marlies Knipper¹, Cze Chim Lee¹, Annalisa Zuccotti¹, Thomas Schimmang², Wibke Singer¹, Lukas Rüttiger¹

¹University of Tübingen, Molecular Physiology of Hearing, Elfriede-Aulhorn-Str. 5, 72076 Tübingen, Germany

²Instituto de Biología y Genética Molecular, Universidad de Valladolid y Consejo Superior de Investigaciones Científicas, E-47003 Valladolid, Spain

The precision of sound information transmitted to the brain depends on the transfer characteristics of the inner hair cell (IHC) ribbon synapse and its multiple contacting auditory fibers (Buran et al., 2010). A permanent IHC ribbon loss and deafferentation occurs after acoustic trauma that is discussed in the context of age-dependent hearing loss, hyperacusis or tinnitus (Kujawa and Liberman, 2009; Lin et al., 2011; Rüttiger et al., 2012). Brain-derived nerve growth factor (BDNF) has been discussed since long as a factor that is essential for survival of spiral ganglia neurons and sprouting of its afferent dendrites (Pettingill et al., 2011). Voltage-activated L-type Ca²⁺ channels like Cav1.2 are assumed to play a crucial role for controlling release properties of neurotrophic peptides including brain-derived nerve growth factor (BDNF). We conditionally inactivated BDNF and Cav1.2 in the auditory system using Cre recombinase under the promoter of Pax2 that would lead to a deletion of genes in the cochlea, dorsal cochlear nucleus (DCN), inferior colliculus (IC) and cerebellum (Ohyama and Groves, 2004; Zuccotti et al., 2012). Efferents, that originate in the olivocochlear system in the brainstem and terminate axodendritically on afferent type I fibers (Warr and Guinan, 1979) have been shown to influence hair cell and afferent physiology (Liberman and Gao, 1995; Darrow et al., 2006). We therefore compared conditional mice with cochlear gene deletion with those conditional mice in which genes are either deleted in the superior olivocochlear complex (SOC) or in the brain. The results are discussed in the context of a presumptive crucial role of BDNF and Cav1.2 for sound coding through setting feedback crosstalk between the peripheral and central auditory system.

Supported by a grant from the Marie Curie Research Training Network CavNET MRTN-CT-2006-035367, Deutsche Forschungsgemeinschaft, grant DFG-Kni316-8-1

Optogenetic manipulation of neuronal activity patterns in the mouse auditory cortex in the context of a go/nogo task.

Juliane Tinter¹, Bruno de Palma Pedrosa Fontinha¹, Brice Bathellier¹, Simon Rumpel¹

¹Research Institute of Molecular Pathology IMP, Rumpel group, Dr. Bohr-Gasse 7, 1030 Vienna, Austria

- Patterns of neuronal activity are believed to be the neuronal correlate of higher-order brain functions and underlie perception. Indeed, early studies by Penfield¹ in epileptic patients undergoing surgery showed that electrical stimulation of the auditory cortex can evoke auditory percepts, hallucinations and trigger memory recall. However, how such crude manipulations of neuronal activity can evoke surprisingly detailed percepts and what the specific properties of evoked activity patterns are remains unresolved.
- Here, we initiated methodological approaches to investigate the effects of artificially evoked activity patterns in the auditory cortex of mice in the context of a perceptual discrimination task. In a first attempt to manipulate activity in a spatially broad, but temporally well controlled manner, we infected a sub-population of cells in the mouse auditory cortex with an adeno-associated viral (AAV) construct encoding Channelrhodopsin-2 (ChR2)-EYFP, a light-gated ion channel fused to a fluorescent protein under a neuronal promoter (Synapsin), which evokes action potentials in neurons upon activation². Following 3-6 weeks of expression we chronically implanted a glass window above the auditory cortex that allowed optical stimulation of infected neurons using a temporally head-mounted LED.³
- In order to test if manipulation of neuronal activity is successful and can be perceived, we trained mice in a modified version of a behavioral go/no lick discrimination task, originally designed for the auditory modality⁴. Two target stimuli are used to cue either a positively reinforced trial in which licking at a spout leads to a water reward or a negatively reinforced trial in which an aversive air puff can be avoided by suppression of licking. In the modified version of the task mice learn to discriminate trials in which a blue light burst (5x5ms at 20Hz) that leads to artificial co-activation of the infected neuronal population is used as a cue or alternative trials with no stimulation. We found that mice can learn to perform the task, independent if the optogenetic stimulation predicted the reward or the air puff. This is consistent with previous findings of artificial stimulation of the auditory cortex using electrical stimulation⁵ or optogenetic stimulation in other modalities³.
- Furthermore, the design of the discrimination task allowed probing in how far artificial stimulation would be generalized to auditory stimuli. We previously observed that mice trained in the task spontaneously categorize non-reinforced (off target) stimuli by responding with consistent lick/no lick behavior depending if the stimulus is perceived more similar to the positively or negatively reinforced target stimulus. When presenting sound stimuli to mice trained to detect artificial auditory cortex stimulation, we found that mice generalized to white noise auditory stimuli, at least when a population of neurons covering large parts of the auditory cortex was infected.

In ongoing studies we train mice to discriminate trains of white noise burst stimuli of two different frequencies and we probe for interference in behavioral performance when simultaneous optical stimulation is applied at various frequencies. These experiments will offer an entry point for the analysis of artificially evoked neuronal activity patterns that underlie perception in an experimentally well tractable model organism.

Citations:

1. Penfield, W. & Perot, P. The Brain's Record of Auditory and Visual Experience. A Final Summary and Discussion. *Brain* 86, 595-696 (1963).
2. Nagel, G., et al. Channelrhodopsin-2, a directly light-gated cation-selective membrane channel. *Proc Natl Acad Sci U S A* 100, 13940-13945 (2003).
3. Huber, D., et al. Sparse optical microstimulation in barrel cortex drives learned behaviour in freely moving mice. *Nature* 451, 61-64 (2008).
4. Bathellier, B., Ushakova, L., Rumpel, S. Discrete neocortical dynamics predict behavioural categorization of sounds. *Neuron*, in press.
5. Otto, K.J., Rousche, P.J. & Kipke, D.R. Microstimulation in auditory cortex provides a substrate for detailed behaviors. *Hear Res* 210, 112-117 (2005).

Distorted hearing in mice lacking the $\alpha_2\delta_3$ Ca^{2+} channel subunit – a model for an auditory processing disorder

Jutta Engel¹, Antonella Pirone², Simone Kurt³

¹Saarland University, Department of Biophysics, Homburg/Saar, Germany;

²University of Tübingen, Department of Otolaryngology, Tübingen Hearing Research Centre (THRC) Tübingen, Germany;
present address: Tufts Medical School, Department of Neuroscience, Boston, MA, U.S.A.;

³University of Ulm, Institute of Neurobiology, Ulm, Germany

The auxiliary subunit $\alpha_2\delta_3$ modulates the expression and functional properties of voltage-gated calcium channels. We found $\alpha_2\delta_3$ mRNA expression in spiral ganglion neurons and midbrain auditory nuclei. Genetic deletion of $\alpha_2\delta_3$ in mice led to mildly increased hearing thresholds in both click (5 dB) and frequency (10-15 dB) auditory brainstem response (ABR) measurements. ABR waveforms showed reduced amplitudes of wave II and distortion of waves III and IV in mutants, indicating impaired signal transmission along the auditory pathway. Further, expression of $\text{Ca}_v2.1$ channels was reduced at both somata of spiral ganglion neurons and bushy cells of the ventral cochlear nucleus. Using light and electron microscopy, we found significantly smaller sizes of auditory nerve fibre synaptic boutons, which terminate at bushy cell somata. We propose that the combination of reduced bouton size and smaller numbers of presynaptic Ca^{2+} channels accounts for the acoustic impairments of $\alpha_2\delta_3^{-/-}$ mice. In vivo recordings at the auditory nerve – bushy cell synapses revealed increased first spike latencies and reduced spike rates as a function of stimulus level in $\alpha_2\delta_3^{-/-}$ mice, indicating malfunction of the endbulb of Held synapse. In a behavioural task, auditory learning was assessed by training wildtype and $\alpha_2\delta_3^{-/-}$ mice to discriminate different simple and complex sound signals. As a result, $\alpha_2\delta_3^{-/-}$ mice showed pronounced deficits in discriminating complex acoustic signals. In conclusion, $\alpha_2\delta_3^{-/-}$ mice might represent a model for an auditory processing disorder.

Supported by EU-CAVNET MRTN-CT-2006-035367 and DFG PP1608.

Symposium

S7: Functional organization of presynaptic neurotransmitter release sites

- S7-1** Mechanisms of kHz-transmission at a central synapse
Stefan Hallermann
- S7-2** MOLECULAR CHARACTERIZATION OF THE MINIMAL DOCKING MACHINERY FOR SECRETORY VESICLE EXOCYTOSIS IN CHROMAFFIN CELLS
Heidi de Wit, Girish H. Kedar, Julia Kurps, Ralf Morhrmann, Alex M. Walter, Jakob B. Sørensen, Matthijs Verhage
- S7-3** A transient phosphorylation of Munc18 by PKC underlies post-tetanic potentiation of transmitter release
Özgür Genç, Olexiy Kochubey, Ruud Toonen, Matthijs Verhage, Ralf Schneggenburger
- S7-4** Ultrastructural and Functional Analysis of Synaptic Vesicle Docking and Priming
Cordelia Imig, Jeong-Seop Rhee, Nils Brose, Benjamin Cooper
- S7-5** Control of fast transmitter release by multiple Ca^{2+} channels reflects a non-random spatial organization of channels and vesicles
Ralf Schneggenburger, Felix Schuermann, Yunyun Han, Norbert Babai, Henry Markram, Daniel Keller
- S7-6** Role of the cytomatrix at the active zone in the organization of presynaptic release sites
Anna Fejtova, Claudia Marini, Daria Davydova, Claire King, Carolina Montenegro, Christian Henneberger, Dmitri A. Rusakov, Vesna Lazarevic, Eckart D. Gundelfinger
- S7-7** Shedding light on the functional anatomy of presynaptic active zones
Stephan J Sigrist, Matthias Siebert, Tanja Matkovic

Mechanisms of kHz-transmission at a central synapse

Stefan Hallermann¹

¹European Neuroscience Institute Göttingen , High-frequency Signaling, Grisebachstr. 5 , 37077 Göttingen, Germany

To maximize the speed of information processing, some synapses can sustain high-frequency transmission. However, the limited number of synapses allowing direct recordings has hampered our understanding of the mechanisms of high-frequency synaptic transmission. Here, we establish two-photon microscopy guided recordings from fluorescence labeled presynaptic cerebellar mossy fiber boutons (cMFBs) paired with recordings from postsynaptic granule cells to analyze high-frequency signaling. Remote stimulation of the mossy fiber axon can elicit action potentials at >1 kHz frequency in cMFBs with mean half-width of $123 \pm 9 \mu\text{s}$ ($n = 11$) and minimal action potential broadening during high-frequency transmission. Paired recordings show that frequencies as high as 1 kHz can be transmitted at these synapses. Furthermore, deconvolution of postsynaptic currents in combination with presynaptic capacitance measurements indicates heterogeneous release probabilities and rapid vesicle reloading kinetics. Finally, elevation of the calcium buffer EGTA to 5 mM in the presynaptic terminal had little effect on the initial fast release component, indicating tight coupling between calcium channels and sensors of exocytosis in a subset of vesicles. These data suggest that a variety of functional specializations permits kHz-transmission at a central synapse.

MOLECULAR CHARACTERIZATION OF THE MINIMAL DOCKING MACHINERY FOR SECRETORY VESICLE EXOCYTOSIS IN CHROMAFFIN CELLS

Heidi de Wit¹, Girish H. Kedar¹, Julia Kurps¹, Ralf Morhrmann², Alex M. Walter³, Jakob B. Sørensen³, Matthijs Verhage¹

¹Dept. Functional Genomics and Clinical Genetics, Center for Neurogenomics and Cognitive Research (CNCR), Neuroscience Campus Amsterdam (NCA), VU University Amsterdam and VU University Medical Center, Amsterdam, the Netherlands. ²Dept. of Physiology, University of Saarland, Homburg, Germany

³Dept. of Neuroscience and Pharmacology, Faculty of Health Sciences, University of Copenhagen, Copenhagen, Denmark

In electron micrographs of synapses and chromaffin cells, many synaptic and secretory vesicles are found docked at the target membrane. Docking is generally considered to be a necessary first step before vesicles gain fusion-competence, but it is unknown how vesicles dock. We studied docking and fusion of secretory vesicles in mouse embryonic chromaffin cells as a preferred docking model, because docking phenotypes are typically more evident than in other systems studied so far (see for a review ¹). Previously we showed that deficiency of Munc18-1 ² which bind to the neuronal SNARE-complex and syntaxin-1 ³ not only abolished exocytosis, but also produced robust docking phenotypes. Recently we identified SNAP-25 as a novel plasma membrane docking factor and resolved that synaptotagmin-1, the calcium sensor for exocytosis acts as the vesicular docking protein ⁴. Moreover, we showed that overexpression of SNAP-25 which promotes assembly of SNAP-25/syntaxin heterodimers rescues the docking defect observed in chromaffin cells of Munc18-1 knockout mice, whereas vesicle fusion is still impaired. These findings lead us to propose that docking is mediated by binding of synaptotagmin-1 to syntaxin-1/SNAP-25 heterodimers ⁴. However, the molecular identity of this interaction remains to be identified and as a consequence the molecular mechanism how synaptotagmin-1 act in docking is unknown. Our previous results provide some of the strongest available evidence that, in addition to docking, Munc18-1 plays a critical function in downstream events leading to exocytosis ⁴⁻⁵, but for this step also the molecular mechanism is unknown. At least three SNARE complexes seems required for fast vesicle fusion ⁶ and it likely that Munc18-1 controls the formation or stability of these fusogenic SNARE complexes ⁴. In addition, it seems that Munc18-1 also has a function in the regulation of cortical F-actin, which is thought to control access of secretory vesicles to docking sites ⁷, but it is unknown how this is linked to Munc18's function in the secretory pathway. Currently we are investigating how Munc18 acts in cortical F-actin modulation and in post-docking. Finally, we are resolving the molecular properties of synaptotagmin that are required for its docking function by searching for synaptotagmin/SNARE binding mutants that interfere with the docking process.

References:

1. H. de Wit, *Histochem Cell Biol* 134 (2), 103 (2010).
2. T. Voets, R. F. Toonen, E. C. Brian, H. de Wit et al., *Neuron* 31 (4), 581-591 (2001).
3. H. de Wit, L. N. Cornelisse, R. F. Toonen et al., *PLoS ONE* 1, e126 (2006).
4. H. de Wit, A. M. Walter, I. Milosevic et al., *Cell* 138 (5): 935-946 (2009).
5. A. Gulyás-Kovács, H. de Wit et al. *J Neuroscience* 27 (32): 8676-8686 (2007).
6. R. Mohrmann, H. de Wit, M. Verhage et al., *Science* 330 (6003): 502-505 (2010).
7. J. Kurps and H. de Wit, *J Mol Neurosci* 48 (2): 339-346 (2012).

A transient phosphorylation of Munc18 by PKC underlies post-tetanic potentiation of transmitter release

Özgür Genç¹, Olexiy Kochubey¹, Ruud Toonen², Matthijs Verhage², Ralf Schneggenburger¹

¹Ecole Polytechnique Federale de Lausanne, EPFL, Brain Mind Institute, Station 19, 1015 Lausanne, Switzerland ²Department of Functional Genomics, Center for Neurogenomics and Cognitive Research, Neuroscience Campus Amsterdam, VU University Amsterdam, Amsterdam, The Netherlands

During and after intense activity at synapses, transmitter output can transiently increase, giving rise to presynaptic forms of plasticity like post-tetanic potentiation (PTP). Previous work has shown that PTP decays in parallel with the residual Ca^{2+} signal in the nerve terminal, and that protein kinase - C (PKC), especially Ca^{2+} sensitive isoforms of PKCs, are necessary for PTP. However, the mechanisms of PKC phosphorylation, including its target protein at the presynaptic release machinery, remain unknown. Here we use the calyx of Held synapse and test the hypothesis that phosphorylation of Munc18-1 (M18), which is involved in the diacylglycerol-mediated potentiation of release in cultured synapses, is involved in PTP. We devised a gene replacement strategy aimed at exchanging endogenous M18 at the calyx of Held, with a M18 protein with deficient PKC phosphorylation sites (M18-3SA mutant). For this purpose, we used M18 floxed mice, and novel adenovirus vectors that could drive the expression of up to three proteins (Cre -recombinase and GFP alone, or in combination with either wild -type or mutant M18). Expression of Cre-recombinase alone led to a near-complete loss of depolarization-evoked transmitter release at infected calyx of Held synapses in M18 floxed mice, showing the efficiency of Cre-mediated recombination. Expression of Cre-recombinase together with wild -type or M18 -3SA mutant, led to a near-complete, and equal rescue of fiber-stimulation evoked EPSCs at the calyx of Held. Importantly, however, PTP was strongly reduced (by $\sim 2/3$) when the PKC-deficient mutant M18-3SA was re-expressed, whereas normal PTP was supported by wild-type M18. These results, together with experiments with the phosphatase inhibitor Calyculin, show that a transient phosphorylation of Munc18-1 by PKC underlies post-tetanic potentiation.

Ultrastructural and Functional Analysis of Synaptic Vesicle Docking and Priming

Cordelia Imig¹, Jeong-Seop Rhee¹, Nils Brose¹, Benjamin Cooper¹

¹Max Planck Institute of Experimental Medicine, Molecular Neurobiology, Hermann-Rein-Str. 3, 37075 Göttingen, Germany

²GGNB doctoral program "Neurosciences", Germany

Excitation-secretion coupling at nerve cell synapses is a sub-millisecond process that entails the transduction of an electrical stimulus into synaptic vesicle fusion. Before fusion, synaptic vesicles are physically docked to the presynaptic active zone membrane and functionally primed to become fusion competent. In response to an increase in intracellular calcium concentration after the arrival of an action potential, primed vesicles fuse with the plasma membrane and release their neurotransmitter content into the synaptic cleft. Recent studies combining high-pressure freezing (HPF) and freeze-substitution (FS) for electron microscopy indicated that synaptic vesicle docking and priming steps may not reflect independent processes, but rather respective morphological and functional manifestations of the same process, namely of initial full or partial SNARE complex assembly mediated by priming proteins of the UNC-13/ Munc13 family (Weimer et al., 2006; Hammarlund et al., 2007; Siksou et al., 2009). To study vesicle docking, we utilize a combination of organotypic hippocampal slice culture, HPF and FS as well as electron tomography to reinvestigate the role of key synaptic proteins in synaptic vesicle docking in glutamatergic hippocampal spine synapses. This method enables the analysis of synaptic parameters in an in-situ-like setting using lethal mouse mutants that do not survive birth. The focus of the present study is on proteins of the CAPS and Munc13 families and their respective roles in regulating synaptic vesicle exocytosis in excitatory hippocampal synapses.

Control of fast transmitter release by multiple Ca^{2+} channels reflects a non-random spatial organization of channels and vesicles

Ralf Schneggenburger², Felix Schuermann¹, Yunyun Han², Norbert Babai², Henry Markram¹, Daniel Keller¹

¹Laboratory of Neural Microcircuitry, ²Laboratory of Synaptic Mechanisms, Brain Mind Institute, Ecole Polytechnique Federale de Lausanne, EPFL, Lausanne, Switzerland

Transmitter release at CNS synapses occurs at highly specialized contact sites, the active zones. It is generally accepted that Ca^{2+} channels and docked vesicles must co-localize at distances of tens of nanometers or less, in order to allow short Ca^{2+} diffusion times and fast vesicle fusion. Nevertheless, there is little ultrastructural data showing the exact spatial relationship between Ca^{2+} channel and vesicles at CNS active zones. Furthermore, functional studies disagree whether fast transmitter release is controlled by few or even a single Ca^{2+} channel ("nanodomain coupling"), or else, by several Ca^{2+} channels ("domain overlap"). A possible functional advantage of domain overlap is that a high Ca^{2+} current - release cooperativity (power law of $\sim 3 - 4$) can be achieved by modulating the number of open Ca^{2+} channels, as is also observed experimentally at the calyx of Held model synapse.

Here, we explore rules of co-localization of Ca^{2+} channels with respect to docked vesicles, using a realistic Monte-Carlo model of a single CNS active zone. Parameters of single-channel Ca^{2+} current, overall Ca^{2+} current density, Ca^{2+} buffering as well as the on- and off-rates of the fast Ca^{2+} sensor for vesicle fusion were fixed from previously available data at the calyx of Held. To arrive at a realistic distribution of docked vesicles at the active zone, we analyzed $n = 15$ reconstructed active zones from serial EM images of calyces of Held from a P11 mouse. These showed that docked vesicles were randomly distributed over the active zone, at a high overall density (~ 100 vesicles / μm^2). We modelled an example active zone which showed 6 docked vesicles and we assumed the presence of 18 - 20 Ca^{2+} channels. We show that clusters of Ca^{2+} channels positioned in-between docked vesicles, but respecting a minimal distance to each docked vesicle of at least 50 nm, were necessary to yield a high Ca^{2+} current - release cooperativity in the simulations. In contrast, when Ca^{2+} channels were placed randomly, a low Ca^{2+} current - release cooperativity resulted, because the chance that single close-by Ca^{2+} channels dominate the release of individual vesicles was high. We conclude that synapses with release control by several Ca^{2+} channels must have a mechanism of keeping Ca^{2+} channels at a certain critical distance from each vesicle. Therefore, domain overlap control of release represents a non-random spatial arrangement of Ca^{2+} channels and vesicles, which is optimized to guarantee a high Ca^{2+} current - release cooperativity.

Role of the cytomatrix at the active zone in the organization of presynaptic release sites

Anna Fejtova¹, Claudia Marini¹, Daria Davydova¹, Claire King², Carolina Montenegro¹, Christian Henneberger², Dmitri A. Rusakov², Vesna Lazarevic¹, Eckart D. Gundelfinger¹

¹Leibniz Inst. for Neuobiology, Neurochemistry and Molecular Biology, Brenneckestr. 6, 39118 Magdeburg, Germany

²Institute of Neurology, University College London, London, UK

The functional performance of nervous system relies on synaptic transmission between neurons. A key event during synaptic transmission is the depolarization-driven calcium transient, which induces fusion of synaptic vesicles with the presynaptic membrane. The mediator between membrane depolarization and SV exocytosis is the diffusible Ca²⁺ ion, which enters the presynaptic boutons through voltage-dependent calcium channels (Cavs). Due to the low intracellular abundance of Ca²⁺ there is a sharp concentration gradient around the channel pores. Rapid and reliable synchronous release of neurotransmitter requires therefore exact localization of Cavs relative to the exocytic machinery. In presynapses of conventional brain synapses, calcium influx is mediated mainly via Cav2.1 (P/Q-type) and Cav2.2 (N-type) channels, which differ in their properties and their contribution to synaptic transmission during development and in synaptic plasticity. The coupling of Cav2.1 or Cav2.2 crucially determine strength of given synapse. However, the mechanism of their differential recruitment to release sites is largely unknown. I will discuss our recent findings regarding molecular players and signaling cascades involved in this process. I will focus on the role of components of presynaptic cytomatrix assembled at the active zone in positional priming of Cavs at the synapse and also touch the mechanisms driving remodeling of release sites during rapid and prolonged plasticity of presynaptic function.

Shedding light on the functional anatomy of presynaptic active zones

Stephan J Sigrist^{1,2}, Matthias Siebert^{1,2}, Tanja Matkovic^{1,2}

¹Freie Universität Berlin, Neurogenetics, Takustrasse 6¹, 14195 Berlin, Germany

²NeuroCure, Charité, Charitéplatz 1, 10117 Berlin, Germany

The majority of rapid cell-to-cell communication mechanisms and information processing within the nervous system makes use of chemical synapses. Thereby, the molecular organization of presynaptic active zones, the places where neurotransmitter filled synaptic vesicles get released, is a focus of intense investigation. We recently identified two key scaffold proteins for presynaptic active zone organization, Bruchpilot (BRP) and Rim-binding protein (RBP)(1, 2), which are essential for structural organization and efficient neurotransmitter release at active zones in *Drosophila*. To overcome the resolution limit of standard light microscopy precluding the study of sub-synapse organization, we use super-resolution light microscopy (stimulated emission depletion microscopy, STED). Thus, functional molecular architectures connecting BRP and RBP with Ca²⁺ channels and release machinery could be studied. Our group moreover established protocols to directly visualize protein dynamics during synapse assembly and plasticity in living intact larvae over extended periods. Thus, we could characterize mechanisms of trans-synaptic signaling connecting assembly of the presynaptic active zone scaffold with postsynaptic assembly (3).

1. K. S. Liu et al., *Science* 334, 1565 (Dec 16, 2011).
2. R. J. Kittel et al., *Science* 312, 1051 (May 19, 2006).
3. D. Oswald et al., *Nat Neurosci* 15, 1219 (Aug 5, 2012).

Symposium

S8: Neurochemical control of social behaviour insects

- S8-1** Octopamine neuromodulation regulates the Gr32a pathway to promote aggression in *Drosophila* males
Sarah J Certel, Jonathan C Andrews, María Paz Fernández, Qin Yu, Peter Evans, Kyung-An Han, Edward A Kravitz
- S8-2** Experience dependent plasticity of aggression in crickets and its control by neuromodulators
Jan Rillich, Paul Anthony Stevenson
- S8-3** Serotonergic signalling pathways and the control of phase change and swarming in Desert Locusts
Swidbert Roger Ott
- S8-4** The queen, her pheromones and reproductive hegemony in honey bees
Vanina Vergoz, Julianne Lim, Benjamin P. Oldroyd
- S8-5** Biogenic amines and mechanisms controlling the division of labor in a honeybee society
Ricarda Scheiner, Anna Toteva, Tina Reim
- S8-6** Spatial and temporal expression patterns of serotonin receptor subtypes in the honeybee, *Apis mellifera*
Daniel Rolke, Markus Thamm, Wolfgang Blenau

Octopamine neuromodulation regulates the Gr32a pathway to promote aggression in *Drosophila* males

Sarah J Certel¹, Jonathan C Andrews¹, María Paz Fernández², Qin Yu¹, Peter Evans³,
Kyung-An Han⁴, Edward A Kravitz²

¹University of Montana, Division of Biological Sciences, 32 Campus Drive, 59812 Missoula, USA

²Department of Neurobiology, Harvard Medical School, Boston, MA 02115, USA

³Inositide Laboratory, The Babraham Institute, Cambridge, CB22 3AT, UK

⁴Department of Biological Sciences, University of Texas at El Paso, El Paso, TX, USA

Chemosensory pheromonal information regulates sex-specific behaviour in many organisms, yet the mechanisms by which pheromonal signals are transduced to reliably produce behaviour are not well understood. We demonstrate that male aggression requires signals detected by Gr32a-expressing chemosensory neurons and this response is directly amplified through neurons that contain the neuromodulator octopamine (an invertebrate equivalent of norepinephrine). Males lacking both octopamine and the Gr32a receptor exhibit significant delays in the onset of aggression and a reduction in aggressive behavior. Selective ablation of only the Gr32a receptor-expressing proboscis neuron population resulted in a significant decrease in aggression without an increase in male-male courtship behavior. GRASP system experiments indicate Gr32a receptor-expressing proboscis neurons specifically contact OA neurons in the subesophageal ganglion.

To investigate how OA signaling might transduce aggression-promoting stimuli, we activated OAB1R receptor neurons in males and observed a significant increase in the number of lunges. Reducing OAB1R expression, by contrast, resulted in males displaying decreased numbers of lunges. Results from anatomical GRASP system experiments identify putative Gr32a to octopamine neuron synaptic connections and distinct octopamine to OAB1R contacts in the suboesophageal ganglion. Our findings demonstrate that octopaminergic neuromodulatory neurons function as early as a second-order step in a chemosensory-driven pathway and contribute to characterizing distinct neural circuits mediating sex-specific behavior.

Experience dependent plasticity of aggression in crickets and its control by neuromodulators

Jan Rillich¹, Paul Anthony Stevenson²

¹Free University of Berlin, Institute for Neurobiology, Koenigin Luise Str. 28-30, 14195 Berlin, Germany

²University of Leipzig, Institute for Biology, Talstr. 33, 04103 Leipzig, Germany

The expression of aggressive behaviour is highly plastic and depends to a great extent on previous and ongoing experiences. Work in our laboratory is revealing how aminergic and other neuromodulatory systems mediate the influence of a wide variety of experiences on the fighting behaviour of adult male crickets. As in many animals, physical exertion, winning and resource possession all lead to a transient increase in aggressiveness which in crickets lasts some 20-30 minutes, whereas social defeat (losing) suppress it for hours. Pharmacological manipulations reveal that the promoting effects of physical exertion (e.g. flying), winning a fight and possession of a resource (e.g. a shelter) are each mediated by the amine octopamine, the invertebrate counterpart to adrenaline/noradrenaline. The data suggest that both physical exertion as well as the perception of potentially rewarding aspects of an experience can activate the octopaminergic system and thereby promote the decision to fight. By manipulating information exchange between fighting crickets, on the other hand, we have shown that a cricket makes the decision to flee when the sum of its opponent's agonist signals surpasses some critical level, as proposed by the cumulative assessment hypothesis. Pharmacological manipulations suggest that the concomitant suppression of aggression depends on activation of the nitric oxide/cyclic GMP, and possibly dopaminergic, signaling systems. Together our data illustrate how experiences control the decision to fight or flee simply by recruiting neuromodulator systems that tune the underlying behavioural thresholds relative to each other. We propose that potentially rewarding experiences increase the propensity to fight via the modulatory action of octopamine. Aversive experiences, such as the opponents agonistic actions, in contrast, will promote the propensity to flee via the action of nitric oxide, dopamine and possibly other neuromodulators.

Supported by the DFG (FOR 1363, STE 714/4-1).

Serotonergic signalling pathways and the control of phase change and swarming in Desert Locusts

Swidbert Roger Ott¹

¹University of Cambridge, Department of Zoology, Downing Street, CB2 3EJ Cambridge, United Kingdom.

The socially induced and fully reversible transformation of Desert Locusts (*Schistocerca gregaria*) between an inconspicuous, lone-living *solitarious phase* and a radically different *gregarious phase* exemplifies the extent to which animals can tailor their phenotype to the conditions they encounter. *Phase change* thus provides a powerful model to analyse both the mechanisms and the functional consequences of neuronal plasticity. In the solitarious phase, Desert Locusts occur at very low population densities and avoid conspecifics. Sporadic desert rains provide transient opportunities for population growth, but as the rains cease, competition drives locusts onto shrinking patches of vegetation. The resultant crowding induces a rapid (1–4 h) reprogramming of behaviour to that typical of the gregarious phase. Critically, this includes mutual attraction that can escalate into the formation of swarms comprising billions of locusts. Comprehensive changes in physiology and morphology follow later through chronic exposure to conspecifics. How do social cues bring about this fateful behavioural reconfiguration?

We were able to demonstrate that specific sensory stimuli from conspecifics cause a rapid but transient (less than 24 h) increase in serotonin in the thoracic CNS. This increase correlates with the degree of the newly acquired gregarious behaviour. Moreover, blocking the synthesis of serotonin or its action on receptors prevents gregarization in the face of gregarising stimuli; and serotonin by itself is sufficient to bring about the transition to gregarious behaviour. Using a combination of classic pharmacological intervention and RNA interference we have identified protein kinase A (PKA) as a primary target of the initial serotonin-mediated stage of gregarization (see figure). We present evidence that the subclasses of serotonergic neurons responsible for the transition to gregarious behaviour are distinct from those that produce altered regulation of behaviours in the fully established phases.

Our combined evidence shows that the serotonin/PKA signalling cascade, which is implicated in diverse forms of learning, acts as a pivot in a behaviour-environment feedback loop that ultimately drives the manifestation of two radically different phenotypes. Gregarization resembles learning in that locusts “remember” the experience of crowding and modify their behaviour. This encompasses changes in the individual’s social interactions, which feed back onto the individual to reinforce its new behavioural state. In this, gregarization resembles other socially induced transitions between behavioural states such as subordination after defeat and the onset of clinical depression. Our identification of a pivotal role for serotonin/PKA signalling shows that these similarities extend to the co-option of common molecular mechanisms.

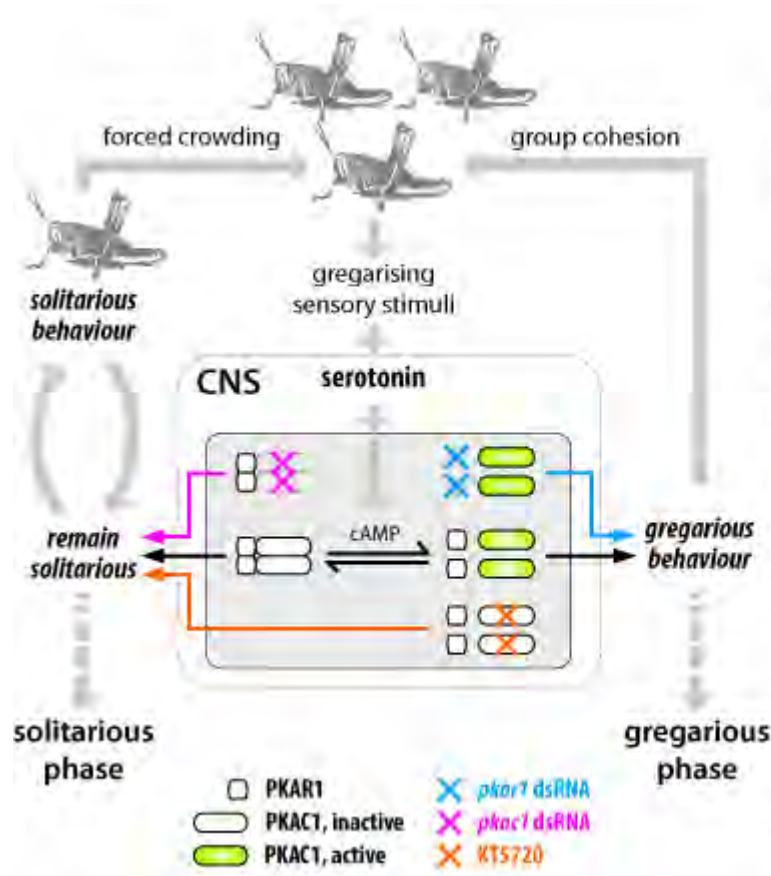

Serotonin / PKA signalling is a molecular pivot in the acquisition of gregarious behaviour. Solitary locusts avoid conspecifics, but when forcibly crowded, a rapid rise in serotonin synthesis and release in the CNS switches them to gregarious behaviour, which ensures further exposure to gregarising stimuli. Pharmacological inhibition (KT5720) or RNAi against catalytic subunit PKAC1 and regulatory subunit PKAR1 identifies a critical role for PKA as effector of the serotonin signal. Locusts with reduced PKAC1 activity or expression gregarize less upon crowding, whereas RNAi against PKAR1 leads to more extensive gregarization.

The queen, her pheromones and reproductive hegemony in honey bees

Vanina Vergoz¹, Julianne Lim¹, Benjamin P. Oldroyd¹

¹¹¹¹University of Sydney, School of Biological Sciences, room 253, A12 Macleay, University of Sydney, 2006 Sydney, Australia

Evolution of worker sterility remains an unsolved puzzle in biology, and the molecular pathways by which the queen regulates the fertility of her workers is poorly understood. In the presence of their queen, workers have inactive ovaries and this inhibition is mediated in part by queen mandibular pheromone (QMP). Removal of the queen from a colony removes the QMP, and workers respond by activating their ovaries. Interestingly, ovary activation is associated with increased levels of the biogenic amine dopamine, suggesting that QMP may regulate ovary activation via dopamine. However, the means by which QMP and dopamine interact to regulate worker sterility remain unclear.

We have analysed patterns of expression of biogenic amine receptors in the brain and the ovaries of workers reared in presence or absence of the queen using real time quantitative PCR. Surprisingly, biogenic amine receptors are expressed in the ovary, a non-neuronal tissue, suggesting that biogenic amines act directly on ovaries. The pattern of expression of amine receptors differs between brain and ovary. In contrast to the brain, where all three dopamine receptors are expressed, only two dopamine receptors are expressed in ovaries, and the expression of these receptors is strongly correlated with the reproductive status of workers. We conclude that biogenic amine receptors are expressed in the ovaries and are likely to be directly influential in the regulation of worker sterility in honey bees when the queen is in the colony.

Biogenic amines and mechanisms controlling the division of labor in a honeybee society

Ricarda Scheiner¹, Anna Toteva¹, Tina Reim¹

¹Universität Potsdam, Institut für Biochemie und Biologie, Karl-Liebknecht-Str. 24-25, Haus 26, 14476 Potsdam, Germany

Honey bee societies display a complex division of labor, which is, nevertheless, very flexible. Normally, young bees perform nursing tasks in the center of the hive, while older bees forage outside the hive for proteins (pollen) and carbohydrates (nectar). But when conditions require it, foragers can revert to nurse bees and nurse bees can forage precociously. Both processes require drastic physiological changes. How can a small insect like the honey bee control division of labor in such an elaborate way? A current hypothesis assumes that differences in individual response thresholds are the basis for division of labor. However, few behavioral response thresholds have been determined. We show that bees performing different tasks have different sensory response thresholds for gustatory and visual stimuli. These differences in response thresholds correlate with a differential expression of biogenic amine receptor genes. Our data suggest that biogenic amines and their receptors regulate division of labor through differential modulation of behavioral response thresholds.

Spatial and temporal expression patterns of serotonin receptor subtypes in the honeybee, *Apis mellifera*

Daniel Rolke¹, Markus Thamm¹, Wolfgang Blenau²

¹Institute for Biochemistry and Biology, University of Potsdam

²Institut für Bienenkunde (Polytechnische Gesellschaft), Goethe University Frankfurt, Oberursel

The hormone and neurotransmitter serotonin (5-HT) controls and modulates a great variety of physiological and behavioral processes by interacting with various 5-HT receptor subtypes. In the honeybee, *Apis mellifera*, four 5-HT receptor subtypes have been characterized: Am5-HT1A, Am5-HT2a, Am5-HT2 β , and Am5-HT7. Interestingly, Am5-HT2 receptors are expressed both as a full length transcript and as a shortened splice variant, as it is known for certain dopamine receptors in *Caenorhabditis elegans* and humans. The tissue specific expression patterns of both Am5-HT2 receptors were investigated in the honeybee using quantitative real-time PCR. In the nervous system and exocrine glands the expression of the full length Am5-HT2a transcript was higher than that of the shortened splice variant, whereas the opposite holds true for Am5-HT2 β . However, eusocial insect societies are characterized by division of labour. The age dependent division of labour in honeybees is correlated with increasing serotonin levels in the brain and is associated with the development of circadian activity rhythms. We compared the 5-HT receptor expression between different age groups. Moreover, we looked at daily oscillations of 5-HT receptor mRNA.

Symposium

S9: Timescales in neuronal population encoding and their biophysical basis

S9-1 Retracted

S9-2 Short-term synaptic plasticity shapes the balance between excitation and inhibition during ongoing cortical activity
Ilan Lampl

S9-3 Multiple timescales of information representation in neurons and networks
Adrienne Louise Fairhall

S9-4 The activity of medullary lateral line units of common Rudd, *Scardinius erythrophthalmus*, which were exposed to Kármán vortex streets
Adrian Klein, Jan Winkelkemper, Evelyn Dylka, Horst Bleckmann

S9-5 K⁺ channels affect cortical neuron input encoding on multiple time scales
Matthew Henry Higgs

S9-6 Non-invasive characterization of individual neurons' computational properties using Continuous dynamic photo-stimulation
Ahmed El Hady , Andreas Neef, Elinor Lazarov, Kai Bröking, Theo Geisel , Walter Stühmer , Fred Wolf

S9-7 The best from two worlds: neocortical neurons as integrators with precise spike timing
Clemens Boucsein, Julian Ammer, Jan Benda

Short-term synaptic plasticity shapes the balance between excitation and inhibition during ongoing cortical activity

Ilan Lampl¹

Weizmann Institute of Science, Neurobiology, 234 Hertzl st. , 76100 Rehovot, Israel

The prominent feedback connections between excitatory and inhibitory neurons in the cortex suggest a balanced-state where inhibition modulates excitation. To examine this, we recorded the spontaneous excitatory and inhibitory inputs onto cortical neurons, while inducing shifts in brain-state by altering the depth of anesthesia. Although the rate of both excitatory and inhibitory events decreased under deeper anesthesia, the magnitude of inhibition increased, while excitation was unaffected. Importantly, that excitation was indifferent to the change in inhibition implies that spontaneous cortical activity is not at a balanced-state. To examine the relationship between the magnitude of inhibition and cortical-states, we replayed the temporal patterns of spontaneous inhibitory activity using cortical electrical-stimulation while blocking local excitation. The magnitude of inhibition increased as the rate of stimulation decreased, similar to the observation under deep anesthesia. Surprisingly, this occurred irrespectively of the depth of anesthesia, suggesting that the excitation -inhibition balance during spontaneous cortical activity is determined mainly by the short-term synaptic properties of feedforward inhibitory inputs.

Multiple timescales of information representation in neurons and networks

Adrienne Louise Fairhall¹

¹University of Washington, Physiology and Biophysics, 1705 NE Pacific St, 98195-7290 Seattle, USA

Many neural systems show adaptive properties that govern the way in which they encode information on a range of different timescales. In particular, the intrinsic properties of single neurons can strongly influence neuronal filtering and gain. Through reductions of conductance -based neurons, we demonstrate mechanisms of efficient coding and of longer timescale input transformations. We also show that these properties can dramatically affect the way in which information at different timescales is propagated through feedforward networks.

The activity of medullary lateral line units of common Rudd, *Scardinius erythrophthalmus*, which were exposed to Kármán vortex streets

Adrian Klein¹, Jan Winkelkemper¹, Evelyn Dylida¹, Horst Bleckmann¹

¹University of Bonn, Institute of Zoology, Poppelsdorfer Schloss, 53115 Bonn, Germany¹

Fish sense weak water fluctuations with their lateral line. Fish use their lateral line to detect predators and prey, for schooling, collision avoidance and energy efficient locomotion in unsteady flow. Columnar vortices (e.g. a Kármán vortex street) are shed downstream of a submerged object (i.e. a cylinder) in a wide range of Reynold numbers. Fish use Kármán vortex streets to reduce locomotory costs. Navigating in hydrodynamic perturbations – like Kármán vortex streets - is complex and information on flow perturbations may be advantageous. Peak spiking frequency of peripheral lateral line units coincides with the vortex shedding frequency but no effect on spike rate was found. Up to now it was unclear how vortex street information is processed in higher brain areas. Therefore Rudd were exposed to a Kármán vortex street and the activity of medullary lateral line units was recorded. Unit activity correlated with unsteady flow signatures in terms of spike pattern or spike rate or both. In contrast to the noisy spiking activity of peripheral lateral line units the responses of some medullary units showed a sharp representation of the vortex street cycles (Fig. a). Synchronously obtained particle image velocimetry was used to calculate a correlation map between the flow field and the neuronal activity (Fig. b). A correlation map was found with peak similarity between flow field and neuronal response close to the boundary of the fish which in turn reflects the receptive field (Fig. c). In summary medullary lateral line units are important for the processing of vortex street information.

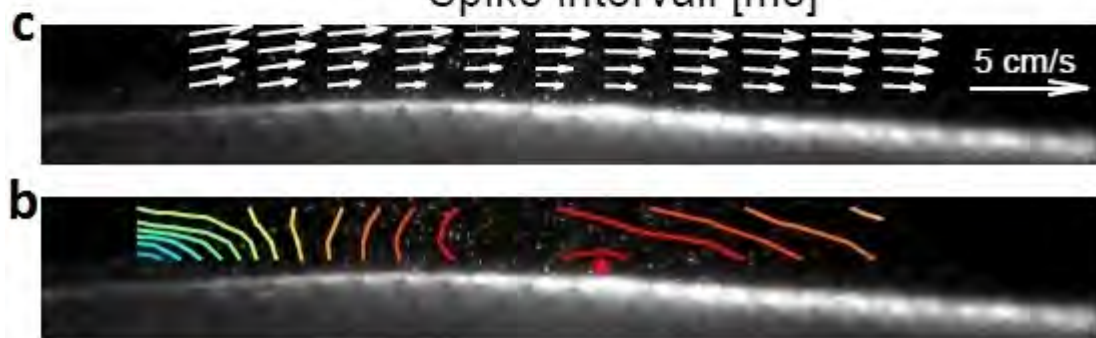
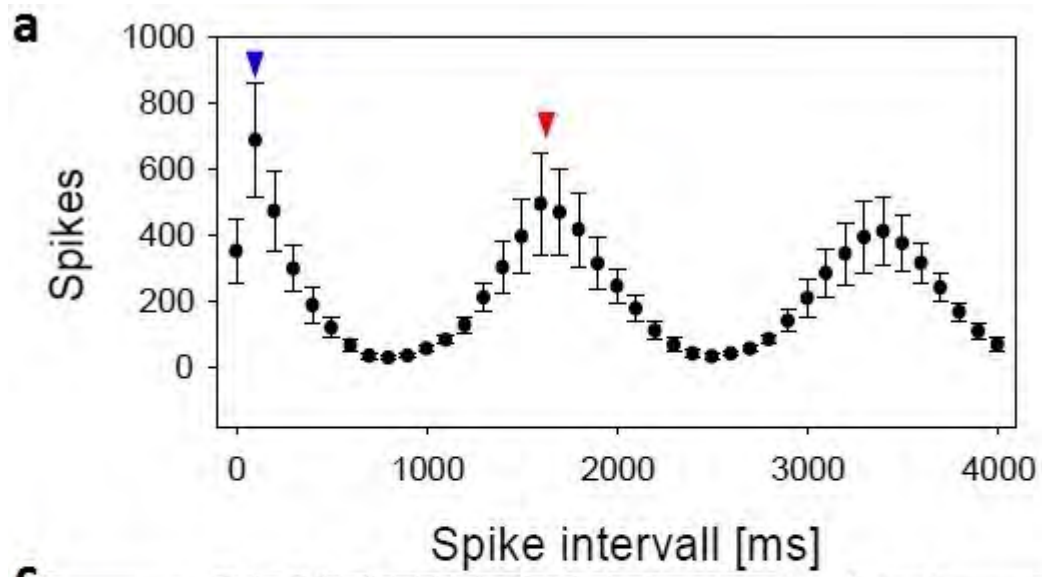

K⁺ channels affect cortical neuron input encoding on multiple time scales

Matthew Henry Higgs^{1,2}

¹Veterans Affairs Puget Sound Health Care System, Neurology, 1660 S. Columbian Way, Seattle, WA 98108, USA

²University of Washington, Physiology & Biophysics, 1705 NE Pacific St., Seattle, WA 98195, USA

This talk will summarize several studies investigating the transformation from current input to spike output in cortical pyramidal neurons. The primary mechanisms discussed are Ca²⁺- and Na⁺-activated K⁺ channels that produce the slow afterhyperpolarization (sAHP), small-conductance Ca²⁺-activated K⁺ (SK) channels that cause the medium afterhyperpolarization (mAHP), and low-threshold voltage-activated Kv1 channels that influence spike threshold and precise spike timing. Our studies have shown that these classes of channels affect neuronal gain on distinct time scales. On slow time scales, the sAHP has at least two kinetic components and produces adaptation with power law-like dynamics. The sAHP conductance reduces gain for low-frequency input (< 1 Hz) and favors a nonlinear effect whereby high-frequency noise increases the gain for low-frequency signals. SK channels reduce gain below ~10 Hz and can produce suprathreshold resonance when the inter-spike intervals are similar to the mAHP duration. Suprathreshold resonance can be strengthened by burst firing, which is driven effectively by oscillating input at ~10 Hz or by much higher-frequency input (200 -300 Hz). Kv1 channels are concentrated in the axon initial segment and play a major role in the dynamics of spike threshold, which rises rapidly in response to an increase in membrane potential. The threshold changes caused by Kv1 channels reduce the ability of low-frequency membrane potential fluctuations to influence spike timing, resulting in greater coherence of spike output with high-frequency input. Together, our results show that cortical pyramidal neurons utilize a variety of K⁺ channels to regulate their input-output properties on a wide range of time scales.

Non-invasive characterization of individual neurons' computational properties using Continuous dynamic photo-stimulation

Ahmed El Hady¹, Andreas Neef^{1,2}, Elinor Lazarov^{1,3}, Kai Bröking¹, Theo Geisel^{1,2},
Walter Stühmer^{2,4}, Fred Wolf^{1,2}

¹Max Planck Institute for dynamics and self organization, Göttingen, Germany.

²Bernstein Center for Computational Neuroscience, Göttingen, Germany.

³Hebrew University of Jerusalem, Rehovot, Israel

⁴Max Planck Institute for Experimental medicine, Göttingen, Germany

Understanding information encoding by individual central neurons requires characterization of their input-output functions under near-natural input conditions, e.g. in the fluctuation driven regime, characteristic of cortical circuits. Controlling the input and registering on the order of 10.000 - 100.000 spikes as output, one can compute transfer metrics which are critical for collective network dynamics, such as dynamic gain, correlation gain or spike frequency vs current (FI-) curves. So far now such data are exclusively obtained in sharp electrode or patch-clamp recordings, where the input to the cell body and therefore to the spike trigger zone in the axon initial segment is directly controlled. Due to the limited number of spikes obtained in invasive recordings, characterization of individual neurons is often not possible, dynamic gain curves, for instance, are averaged over tens of neurons.

We recently developed an alternative, non-invasive method for neuronal characterization. Spikes are recorded by an array of extracellular electrodes. Well-defined, fluctuating stimuli are delivered via light-activated channelrhodopsins to pharmacologically isolated neurons. Careful characterization of channelrhodopsin's transfer function warrants precise control over the waveform of the induced conductance. The non-invasive nature of the experiment enables characterization of many individual neurons for many hours, up to few days. The setup delivers orders of magnitude more data than previously possible in the field of input-output characterization. Neuronal responses were stable, measurement of intracellular pH showed only minor acidification under continuous stimulation. Comparison of our results with dynamic gain measurements and FI-curves obtain with traditional methods establishes the equivalence of the non-invasive, high-throughput method.

The best from two worlds: neocortical neurons as integrators with precise spike timing

Clemens Boucsein^{1,2}, Julian Ammer³, Jan Benda^{3,4}

¹Neurobiology and Biophysics, Faculty of Biology, University of Freiburg, Germany

²Bernstein Center Freiburg, University of Freiburg, Germany

³Department Biology II, Division of Neurobiology, Ludwig-Maximilians-University Munich, Germany

⁴Institute for Neurobiology, University Tübingen, Germany

Psychophysical experiments demonstrate that decisions can be made in surprisingly short time. The limited integration time available for information processing in the cortex suggests a coding scheme that may rely on the concerted action of groups of neurons, i.e. a temporally precise population code. However, neocortical pyramidal cells have been characterized as type-I neurons. Such neurons respond to small inputs with long and variable latencies that would impair quick and precise population responses.

Here, we studied key characteristics of the spike generator, like current-firing frequency curve, phase-response curve and the temporal spiking precision, in principal cells of the neocortex by somatic current injection. According to established classification of pyramidal cells as integrators (type-I spike dynamics), pyramidal cells showed linear f/I -curves, strictly positive PRCs and imprecise spike-stimulus locking at potentials close to spiking threshold. However, we found that both, operating slightly hyperpolarized from threshold, as well as increasing leak conductance (by means of dynamic current clamp), markedly increased spiking precision. At the same time, artificial leak conductance could introduce negative segments in the PRC, and flatten the f/I -relationship, both strong hints towards a qualitative change in spike dynamics. In many neurons, the membrane potential range where pyramidal cells displayed the imprecise spike-stimulus locking typical for type-I excitability was often difficult to reach before cells went into tonic firing, and did not appear at all when membrane conductance was artificially increased. Slightly below threshold as well as under realistic conductance increase (due to synaptic bombardment), spiking dynamics changed qualitatively, leading to strictly precise spiking.

Our data suggest that pyramidal cells of the neocortex are tuned, under physiological conditions, to propagate even small signals with high temporal precision. It is, thus, conceivable that information processing schemes that rely on the precise firing of relatively small populations of cells in neocortical networks could be used for information transfer and processing in the neocortex of mammals.

Funded by the German Federal Ministry of Education and Research (Grants 01GQ0420 to BCCN Freiburg and 01GQ0830 to BFNT Freiburg-Tübingen).

Symposium

S10: Differential brain science: towards an understanding of interindividual variation

- S10-1** Differential brain science in the human sensorimotor corpus callosum
Ulf Ziemann
- S10-2** Interhemispheric connections shape individual conscious experience of visual illusions
Axel Kohler, Erhan Genç, Johanna Bergmann, Wolf Singer
- S10-3** Surface area of early visual cortex predicts individual speed of traveling waves during binocular rivalry
Erhan Genç, Johanna Bergmann, Wolf Singer, Axel Kohler
- S10-4** On the relevance of inter-individual callosal differences for behaviour and experience
René Westerhausen
- S10-5** BRAIN STRUCTURE CORRELATES OF INDIVIDUAL DIFFERENCES IN PERCEPTUAL RIVALRY
Ryota Kanai
- S10-6** Genetic architecture of punishment-, relief-learning and shock avoidance
Mirjam Appel, Claus-Jürgen Scholz, Marcus Dittrich, Tobias Müller, Sami Gödekdag, Samet Kocabey, Sinead Savage, Marie Bockstaller, Tuba Oguz, Hiromu Tanimoto, Ayse Yarali
- S10-7** SPECIALISATION OF THE SPECIALISTS - THE NEUROSCIENCE OF INDIVIDUAL DIFFERENCES
Lutz Jancke

Differential brain science in the human sensorimotor corpus callosum

Ulf Ziemann¹

¹Hertie Institute for Clinical Brain Research and University of Tübingen, Neurology and Stroke, Hoppe-Seyler-Str. 3, 72076 Tübingen, Germany

The corpus callosum (CC) is the principal white matter fiber bundle connecting the two hemispheres of the brain. Diffusion tensor imaging (DTI) allows quantitative measurement of microstructure characteristics. One DTI-derived measure is fractional anisotropy (FA), which represents orientational fiber coherence, fiber size and degree of myelination in fiber bundles. It is however unknown to which extent FA of the CC is related function, e.g. electrophysiological or behavioral measures of interhemispheric connectivity.

In Experiment 1 [Wahl et al. 2007, *J Neurosci* 27: 12132–8] we studied the motor CC connecting the hand areas of the primary motor cortices (M1) in 12 healthy subjects. Effective connectivity was determined by short-latency interhemispheric inhibition measured by a paired-coil transcranial magnetic stimulation protocol. We found that FA of the motor CC connecting the hand areas of M1 but not FA of the motor CC connecting the foot areas of M1 correlated linearly with interhemispheric inhibition between the M1 hand areas. This demonstrated a direct and topographically specific link between microstructure and effective connectivity. In a follow-up study [Wahl et al. 2011, *Hum Brain Mapp* 32:846–55] we showed that this relation was degraded in patients with early-stage relapsing-remitting multiple sclerosis, a condition where the CC is often and early affected by the demyelinating and neurodegenerative processes. This suggests that the study of structure-function relationship may be an early marker of disintegration in cortical networks.

In Experiment 2 [Jung et al. 2012, *J Neurosci* 32:5667–77] we studied the somatosensory CC connecting the primary and secondary somatosensory cortices (S1, S2) in 14 healthy volunteers. Interhemispheric effective connectivity between the S1 and S2 in the two hemispheres was determined by a novel protocol using magnetoencephalographic (MEG) source analysis of conditioning-test median nerve somatosensory evoked fields. Bimanual tactile task performance was tested by a tactile localization task and a haptic object recognition task. We found that FA of callosal fibers interconnecting S2 correlated directly and topographically specifically with interhemispheric inhibition of the contralateral S2 MEG source activity. In addition, interhemispheric inhibition of S2 MEG source activity correlated directly with bimanual tactile task performance. This demonstrated again a close link between microstructure and electrophysiological and behavioral measures of interhemispheric connectivity.

In summary, individual differences in quantitative information of local microstructure of the motor and somatosensory human corpus callosum predict variance in electrophysiological and behavioral measures of interhemispheric information transfer.

Interhemispheric connections shape individual conscious experience of visual illusions

Axel Kohler^{1,2,3}, Erhan Genç^{2,3,4}, Johanna Bergmann^{2,3,5}, Wolf Singer^{2,3,4,6}

¹University of Münster, Institute of Psychology, Fliednerstr. 21, 48149 Münster, Germany

²Max Planck Institute for Brain Research, Department of Neurophysiology, Deutschordenstr. 46, 60528 Frankfurt am Main, Germany

³Brain Imaging Center Frankfurt, Schleusenweg 2-16, 60528 Frankfurt am Main, Germany

⁴Ernst Strüngmann Institute (ESI) for Neuroscience in Cooperation with Max Planck Society, Deutschordenstr. 46, 60528 Frankfurt am Main, Germany

⁵University of New South Wales, School of Psychology, Sydney, Australia

⁶Goethe University, Frankfurt Institute for Advanced Studies, Ruth-Moufang-Str. 1, 60438 Frankfurt am Main, Germany

When we think about differences between individuals, we are used to describe them in terms of variations in outer appearance and personality. But recent research from colleagues and in our lab has demonstrated that people show a large degree of variability even in very basic sensory functions.

We used two paradigms that have been extensively studied in consciousness research: (1) The 'motion quartet', an apparent-motion stimulus, produces alternating perceptions of horizontal and vertical motion without any changes in the physical characteristics of the display. (2) The 'traveling wave' of binocular rivalry uses competing presentations of separate stimuli to the two eyes, which also leads to spontaneous switches in conscious perception. A specific feature of the traveling wave is that the perceptual switches are generated such that the change in perception spreads across the visual field in a controlled manner. Both paradigms show characteristic deviations when neural processing has to be integrated or transferred between brain hemispheres.

We could demonstrate that this cost of interhemispheric transmission is a stable feature of individuals across time. In order to identify the anatomical source of the interindividual differences, we used diffusion tensor imaging and functional magnetic resonance imaging to localize different visual areas and their fiber connections between the left and right hemispheres through the corpus callosum. Our results show that separate connections between early visual (traveling wave) and motion-related (motion quartet) areas predict the respective differences in conscious perception between individuals, revealing a high degree of specificity in the anatomical basis of subjective experience.

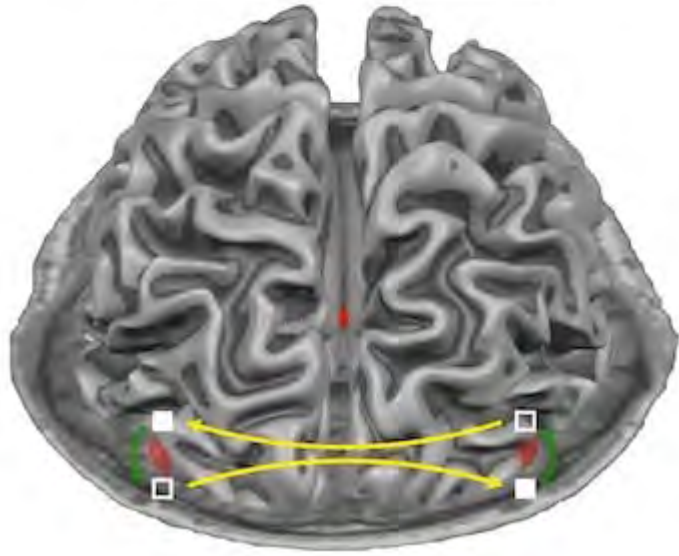
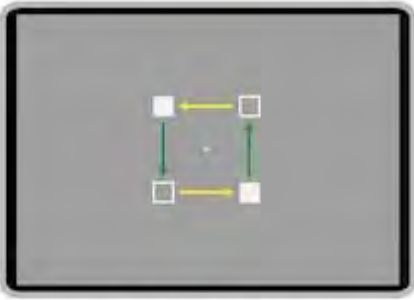

Surface area of early visual cortex predicts individual speed of traveling waves during binocular rivalry

Erhan Genc¹, Johanna Bergmann^{2,5}, Wolf Singer^{2,3,4,6}, Axel Kohler^{2,7}

¹Ruhr-University Bochum, Biopsychologie, GAFO 05/620, 44780 Bochum, Germany ²Department of Neurophysiology, Max Planck Institute for Brain Research, Deutschordenstr. 46, D-60528 Frankfurt am Main, Germany ³Brain Imaging Center Frankfurt, Schleusenweg 2-16, D-60528 Frankfurt am Main, Germany ⁴Ernst Strüngmann Institute (ESI) for Neuroscience in Cooperation with Max Planck Society, Deutschordenstr. 46, Frankfurt am Main, 60528, Germany ⁵School of Psychology, University of New South Wales, Sydney, Australia ⁶Frankfurt Institute for Advanced Studies, Goethe University, Ruth-Moufang-Str. 1, D-60438 Frankfurt am Main, Germany ⁷Institute of Psychology, University of Münster, Fliegenerstr. 21, D-48149 Münster, Germany

Binocular rivalry between competing representations ensues when different images are presented to the two eyes with conscious perception alternating between the possible interpretations every few seconds. For large rivalry displays, perceptual transitions are often initiated at one location and spread to other parts of the visual field, a phenomenon termed traveling wave. Previous studies investigated the characteristics of the traveling wave and the underlying neural mechanisms and surmised that early visual areas and especially primary visual cortex might play an important role. In the current study, we used magnetic resonance imaging and behavioral measures in humans to explore how interindividual differences in observers' subjective experience of the wave are related to anatomical characteristics of different cortical regions.

We measured wave speed in a group of participants and confirmed the long-term stability of the individual values after several weeks. Retinotopic mapping was employed to delineate borders and extent of early visual areas V1-V3 in order to determine surface area and cortical thickness in those regions. Only the surface areas of V1 and V2, but not V3 showed a correlation with wave speed across participants. For individuals with larger V1/V2 area, the traveling wave needed longer to spread across the same distance in visual space. Our results demonstrate that anatomical characteristics of specific cortical areas predict the individual propagation of traveling waves, providing further evidence that V1 is an important site for neural processes underlying binocular rivalry.

On the relevance of inter-individual callosal differences for behaviour and experience

René Westerhausen¹

¹University of Bergen, Dept. Biol. & Med. Psychology, and Division of Psychiatry, Haukeland University Hospital, Bergen, Norway

The two cerebral hemispheres are specialized for different functions and receive different information about the environment from the sensory organs. Inter-hemispheric communication is crucial for an efficient coordination and integration of hemispheric processing. The corpus callosum, the major white-matter pathway connecting the two hemispheres, provides the anatomical basis for this inter-hemispheric communication. Systematic studies on patients with callosal lesions or surgical transection of the corpus callosum (split-brain patients) further support its functional role. However, structural analyses of the intact corpus callosum also reveal substantial inter-individual differences in its macro- and microstructural properties. This observation leads to the question of the functional relevance of this “normally occurring” callosal variability. Here, data from a series of studies will be presented providing evidence in favour of a structure-function association in the corpus callosum, by showing that callosal structure variability explains individual differences in the inter-hemispheric transfer of auditory information. Throughout these studies auditory transfer was assessed using the dichotic listening paradigm. This consists of presenting series of verbal stimulus pairs (based on consonant-vowel syllables, like /ba/ - /ga/), whereby one to the two stimuli is presented to left and the other one, simultaneously, to the right ear. Instructed to report the syllable heard the best, participants typically report the right stimulus more frequently than the left. This right-ear advantage is usually explained referring to the preponderant contra-lateral projections of the ascending auditory pathways, which lead to a direct access of the right-ear stimulus to speech processing centres located in the left hemisphere. Correct report of left-ear stimuli, however, relies on the efficiency of the inter-hemispheric transfer, since the left-ear stimulus information needs to be transferred from its initial terminal in the right hemisphere via the corpus callosum to gain access to the left-hemispheric speech processing areas. In line with this so-called structural model, the correct left-ear reports in the dichotic listening task correlate with the structural measures of the corpus callosum (midsagittal size of the splenium and isthmus, as well as the size of specific temporal-callosal pathways as determined with diffusion-tensor fibre tracking). A longitudinal study exploring the origin of this structure-function association showed that the growth of the corpus callosum between the age of 6 and 8 years specifically predicts the development of the correct left-ear reports in that time period. Taken together, the present results indicate that inter-individual structural differences in the posterior corpus callosum are relevant for auditory transfer related to speech perception. Furthermore, this structure-function relationship found in the adult corpus callosum may be linked to plastic refinement processes of the inter-hemispheric connections in response to the acquisition of phonological abilities in early school age. However, future studies are required to separate genetic from environmental influences on the development of the observed structure-function association.

BRAIN STRUCTURE CORRELATES OF INDIVIDUAL DIFFERENCES IN PERCEPTUAL RIVALRY

Ryota Kanai¹

¹University of Sussex, School of Psychology, Pevensey Building, BN1 9QH Falmer, United Kingdom

Conscious perception can fluctuate spontaneously between possible interpretations. The timing of such perceptual reversals is stochastic and exhibit large inter-individual differences. We hypothesised that variability in perceptual rivalry may be rooted in structural differences of the brain across individuals. To test this, we collected perceptual switch rates for a structure-from-motion (SFM) stimulus from a group of 52 participants and examined whether variability in brain structure across participants could account for the individual differences in switch rate. We found that the gray matter volume of posterior superior parietal lobe (SPL) in both hemispheres correlated positively with inter-individual differences in switch rate. Diffusion tensor imaging (DTI) of the same participants showed that the integrity of the white matter connecting these SPL regions was greater for those with faster switch rate. On the other hand, an opposite relationship was found in the anterior part of right SPL whose volume negatively correlated with individuals' switch rate. The causal involvement of these regions were confirmed by a series of transcranial magnetic stimulation (TMS) experiments. Transient disruption of both left and right posterior SPL by TMS slowed switch rates, whereas disruption of right anterior SPL made the rate faster. These findings suggest that right anterior SPL is involved in maintenance of the current percept, while posterior SPL prompts switches to alternative percepts. These findings suggest that perceptual rivalry involves dynamic competition between high-level perceptual hypothesis and low-level prediction errors.

Genetic architecture of punishment-, relief-learning and shock avoidance

Mirjam Appel¹, Claus-Jürgen Scholz², Marcus Dittrich³, Tobias Müller³, Sami Gödekdağ¹, Samet Kocabey¹, Sinead Savage¹, Marie Bockstaller¹, Tuba Oguz¹, Hiromu Tanimoto¹, Ayse Yarali¹

¹Max Planck Institute for Neurobiology, Behavioural genetics, Am Klopferspitz 18, 82152 Martinsried, Germany

²Institute of Clinical Biochemistry and Pathobiochemistry, University of Würzburg, Germany

³Department of Bioinformatics, Biocenter, University of Würzburg, Germany

Painful stimuli both release immediate action, and are inscribed in memory to affect future behaviour. Fruit flies for instance innately avoid an electrified T-maze arm. They also readily learn the associative relationship between an odour and electric shock. In fact, an experience with shock leaves two opponent memories: When presented before the shock, an odor is learned to signal 'punishment' and is later on avoided; when presented after the shock it is learned as a signal for 'relief' leading to conditioned approach¹. Both the innate avoidance of shock and the opponent memories about it are conserved up to humans². We used a genome-wide approach in the fruit fly to compare the genetic architecture of shock avoidance, punishment-learning and relief-learning. We took advantage of 38 inbred fly strains that have been characterized in terms of transcript abundance³ and genome sequence⁴. We found significant across-strain variation in all three kinds of behaviour, with no correlation between behaviours. We then looked for genes associated with each behavior, in terms of either expression level or sequence polymorphisms, revealing little overlap in the genetic effectors between behaviours. For each of the three behaviours, we analyzed the arising candidate genes in terms of known function, revealing many with homologues implicated in human disease⁵. Based on known protein-protein interactions and our association results we will now perform gene-network analyses to get a broader picture on signaling pathways and neurotransmitter systems involved in each kind of behaviour. With respect to shock avoidance we went a step further and used reverse genetics to verify the role of 11 genes, corresponding to hit rate of ~ 50%. Among these genes is the heat sensor *trpA1*, suggesting for the first time a possible mechanism for shock-sensation. We are now scrutinizing the roles of further candidates including other thermo- and mechano-sensors as well as genes related to aminergic and peptidergic signaling. In the future, we will undertake such independent verification with respect to punishment- and relief learning, too. This approach for the first time systematically compares the molecular mechanisms of different shock-related behaviours. Especially, with respect to relief learning, of which close to nothing is known, our list of candidate genes should enable a significant leap forward. Finally, considering the molecular conservation across species, the knowledge of fly genes implicated in shock-related behaviours may possibly help neurogenetic trauma-research in humans.

¹Tanimoto et al. 2004, Nat

²Andreatta et al. 2010, Proc Biol Sci

³Ayroles et al. 2009, Nat gen

⁴Mackay et al. 2012, Nat

⁵<http://superfly.ucsd.edu/homophila/>

SPECIALISATION OF THE SPECIALISTS - THE NEUROSCIENCE OF INDIVIDUAL DIFFERENCES

Lutz Jancke¹

¹University Zurich, Neuropsychology, Binzmühlestrasse 14, 8050 Zurich, Switzerland

The last 20 years of neuroscientific research has uncovered many findings supporting the idea that the human brain is shaped (beside genetic influences) by experience. These experience-dependent influences on the neurophysiology and neuroanatomy can be inferred by the many specific anatomical and neurophysiological features of the brain of specialists. In this talk I will present findings from our own lab demonstrating specific anatomical and neurophysiological features identified in musicians, synesthetes and other exceptionally behaving subjects. On the basis of these findings I will discuss the plasticity of the human brain and the associated consequences.

Symposium

S11: Serotonin: from brain development to behavior - new insights from animal models.

- S11-1** Lack of brain serotonin affects postnatal development and serotonergic neuronal circuitry formation
Massimo Pasqualetti
- S11-2** Behavioral and physiological consequences of central 5-HT deficiency in mice
Natalia Alenina
- S11-3** Role of cortical serotonin for sensorimotor processing, anxiety and reinforcement
Christian P. Müller
- S11-4** Early life adversity and serotonin transporter gene variation interact to shape the adult hypothalamo-pituitary-adrenal axis and stress escape behaviour.
Judith R Homberg, Rick van der Doelen, Tamas Kozicz
- S11-5** Ultrasonic communication and social behaviors in rats lacking the serotonin transporter
Markus Wöhr
- S11-6** Cortical hyperconnectivity associated with overexposure to 5-HT during brain development.
Stephanie Miceli, Martijn Selten, Moritz Negwer, Judith Homberg, Dirk Schubert
- S11-7** Behavioral and neurochemical consequences of subtle reduction in central serotonin production in mice
Valentina Mosienko, Susann Matthes, Daniel Beis, Michael Bader, Natalia Alenina

Lack of brain serotonin affects postnatal development and serotonergic neuronal circuitry formation

Massimo Pasqualetti¹

¹University of Pisa, Cell and Developmental Biology Unit, Biology Department, S.S.12 Abetone e Brennero 4, 56127 Pisa, Italy

Despite increasing evidence suggests that serotonin (5-HT) can influence neurogenesis, neuronal migration and circuitry formation, the precise role of 5-HT on central nervous system (CNS) development is only beginning to be elucidated. Moreover, how changes in serotonin homeostasis during critical developmental periods may have etiological relevance to human mental disorders, remains an unsolved question. In this study we address the consequences of 5-HT synthesis abrogation on CNS development using a knock-in mouse line in which the tryptophan hydroxylase 2 (Tph2) gene is replaced by the eGFP reporter. We report that lack of brain 5-HT results in a dramatic reduction of body growth rate and in 60% lethality within the first 3 weeks after birth, with no gross anatomical changes in the brain. Thanks to the specific expression of the eGFP, we could highlight the serotonergic system independently of 5-HT immunoreactivity. We found that lack of central serotonin produces severe abnormalities in the serotonergic circuitry formation with a brain region - and time -specific effect. Indeed, we observed a striking reduction of serotonergic innervation to the suprachiasmatic and thalamic paraventricular nuclei, while a marked serotonergic hyperinnervation was found in the nucleus accumbens and hippocampus of Tph2::eGFP mutants. Finally, we demonstrated that BDNF expression is significantly up-regulated in the hippocampus of mice lacking brain 5-HT, mirroring the timing of the appearance of hyperinnervation and thus unmasking a possible regulatory feedback mechanism tuning the serotonergic neuronal circuitry formation. On the whole, these findings reveal that alterations of serotonin levels during CNS development affect the proper wiring of the brain that may produce long-lasting changes leading to neurodevelopmental disorders.

Behavioral and physiological consequences of central 5-HT deficiency in mice

Natalia Alenina¹

¹MDC, molecular biology of peptide hormones, Robert-Rössle-str. 10, 13125 Berlin, Germany

The monoamine serotonin (5-hydroxytryptamine, 5-HT) plays an important role in a broad range of physiological processes working as an autacoid in the periphery and as a neurotransmitter in the brain. Biosynthesis of serotonin in the periphery and in the brain is limited on the first step by two distinct tryptophan hydroxylase enzymes, TPH1 and TPH2, respectively. By genetically ablating Tph2, we created mice which lack serotonin in the central nervous system, without altering its levels in the periphery. Surprisingly, and in contrast to animals lacking other neurotransmitter systems, these mice exhibit normal embryonic development, can be born and survive until adulthood. However, depletion in serotonin signaling in the brain leads to growth retardation in the first weeks of postnatal life in these mice. These growth abnormalities could not be linked to altered food intake or temperature control of Tph2-deficient pups. Morphological study of the cerebral cortex over postnatal development showed a delayed maturation of the upper cortical layers in the Tph2^{-/-} mice, confirming the observation that 5-HT is required for the pre-weaning growth of mouse pups, but that brain development is relatively immune to severe 5-HT depletion.

Behaviour assessment in Tph2-deficient animals revealed extreme aggressiveness and low level of anxiety in conflict tests, including exploratory behaviour in these mice. Moreover Tph2^{-/-} females, despite being fertile and producing milk, exhibit impaired maternal care leading to poor survival of their pups. Furthermore, a depression-like phenotype, observed in the forced swim test in Tph2^{-/-} mice, could be reversed by chronic treatment with the selective serotonin reuptake inhibitor fluoxetine, strongly arguing for a the contribution of non-serotonergic pathways to the action of this antidepressant.

Furthermore, alterations in the control of autonomic functions were evident in Tph2-deficient animals, including disturbances in thermoregulation, cardiovascular function, and respiration. Although serotonin release is known as a negative regulator of appetite, lack of 5-HT resulted in slight increase in food and also liquid consumption. However, these mice tend to accumulate less fat. This phenotype became even more prominent under high fat diet: Tph2-deficient animals were protected from high fat diet-induced obesity and exhibited better performance in metabolic test after 20 weeks of high fat food consumption, probably due to an increased energy expenditure throughout the life.

Thus, Tph2^{-/-} animals represent a unique model to clarify the functional importance of the neurotransmitter serotonin. These mice demonstrate that central serotonin is not essential for life but is a pivotal modulator of numerous autonomic pathways.

Role of cortical serotonin for sensomotor processing, anxiety and reinforcement

Christian P. Müller¹

Friedrich-Alexander-University of Erlangen-Nuremberg, Psychiatric University Clinic, ¹Schwabachanlage 6, 91054 Erlangen
Erlangen, Germany

Ascending serotonergic projections control the activity in virtually all areas of the diencephalon and telencephalon. While the role of serotonin in limbic brain areas is well established in the control of sensomotor processing, emotional behavior and reinforcement, little is known about the specific role of serotonin in neocortical brain areas. It was shown that extracellular serotonin activity increases in the neocortex of rats after sensory stimulation in-vivo in a brain area selective and sense modality specific way. This increase was shown to contribute to stimulus-induced of locomotor activity, emotional behavior and reward learning. Here we discuss recent evidence on the specific role of serotonin in distinct neocortical areas in behavior.

Early life adversity and serotonin transporter gene variation interact to shape the adult hypothalamo-pituitary-adrenal axis and stress escape behaviour.

Judith R Homberg¹, Rick van der Doelen², Tamas Kozicz²

¹Donders Institute for Brain, Cognition, and Behaviour, Department of Cognitive Neuroscience, Geert Grooteplein 21, 6525 EZ Nijmegen, Netherlands

²Donders Institute for Brain, Cognition, and Behaviour, Department of Anatomy, Geert Grooteplein 21, 6525 EZ Nijmegen, Netherlands

Recent essays and reviews in psychiatric translational research have postulated the possibility that, instead of a necessary pathological role of early life adversity, the match or mismatch between the early and later (e.g. adolescent, adult) life environment could determine vulnerability to stress-related psychiatric disorders. It has been established that the low activity variant of the common serotonin transporter promoter polymorphism increases the occurrence of depression following early life stress exposure. To elucidate whether stress in early life can also increase adaptive fitness for later life stress encounters, we tested adult serotonin transporter heterozygous (5-HTT+/-) and homozygous (5-HTT-/-) knockout and wild-type rats - half of which underwent maternal separation in early life - for their ability to avoid footshocks in the learned helplessness paradigm. In a separate group of maternally separated and non-stressed 5-HTT+/-, 5-HTT-/- and wild-type rats we also measured the functioning of the hypothalamo-pituitary-adrenal (HPA) axis, during adulthood. We found that both 5-HTT gene variation and early life treatment had a significant effect on the average escape latency of the rats in the learned helplessness test. Remarkably, the maternal separation group showed increased active coping, which was especially significant in 5-HTT+/- rats. 5-HTT-/- rats showed increased stress escape behaviour regardless of early life maternal separation. We also observed that mRNA levels of the ACTH receptor and 3- α -hydroxysteroid dehydrogenase (3 α -HSD; enzyme involved in corticosterone synthesis) were increased in the adrenals of non-stressed 5-HTT-/- rats, but decreased in 5-HTT-/- rats that had been exposed to maternal separation. Corticosterone levels in blood plasma followed the same gene x environment interaction. Together our data show that 5-HTT-/- rats are well adapted by nature to cope with controllable stress, and 5-HTT+/- rats after early life stress experiences. These data have heuristic value for the design of individualized therapies in depression.

Ultrasonic communication and social behaviors in rats lacking the serotonin transporter

Markus Wöhr¹

¹Philipps-University of Marburg, Experimental and Physiological Psychology, Gutenbergstr. 18, 35032 Marburg, Germany

Rats emit distinct types of ultrasonic vocalizations (USVs), which serve as situation-dependent affective signals. Juvenile and adult rats emit low-frequency 22-kHz USVs (“alarm calls”) in aversive situations such as predator exposure (Blanchard et al., *Physiol Behav*, 1991), fear conditioning (Yee et al., *J Psychiatr Res*, 2012) or social defeat (Kroes et al., *Behav Brain Res*, 2007), whereas high-frequency 50-kHz USVs (“rat laughter”) occur in appetitive situations such as social play (Knutson et al., *J Comp Psychol*, 1998) or when exposed to drugs of abuse like amphetamine (Thompson et al., *Behav Brain Res*, 2006). In support of a communicative function, it was demonstrated by means of playback experiments that 50-kHz and 22-kHz USVs induce call-specific behavioral responses in the recipient. While 50-kHz USVs induce social approach behavior, supporting the notion that they serve as social contact calls, 22-kHz USVs lead to freezing behavior, indicating an alarming function (Wöhr & Schwarting, *PLoS One*, 2007). These opposite behavioral responses are paralleled by distinct patterns of brain activation; with aversive 22-kHz USVs inducing activation in amygdala and periaqueductal gray, both implicated in the regulation of anxiety and fear, whereas pro-social 50-kHz USVs evoke neuronal activation in the nucleus accumbens, strongly implicated in reward processing (Sadananda et al., *Neurosci Lett*, 2008). Serotonin (5-hydroxytryptamine, 5-HT) is a monoamine neurotransmitter with major impact on brain development in mammals. Upon release, extracellular levels of 5-HT are primarily regulated by reuptake through the 5-HT transporter (SERT). Several lines of evidence associate altered serotonergic signaling with neuropsychiatric disorders, including autism. Autism is a neurodevelopmental disorder that is behaviorally defined by three core symptoms, namely deficits in social interaction, communication impairment and repetitive behavior. Hyperserotonemia is found in about 30% of autism cases (Schain & Freedman, *J Pediatr*, 1961). Genome-wide and pathway-based association studies led to the identification of several susceptibility genes for autism, including the SERT-encoding gene *Slc6a4* (Sutcliffe et al., *Am J Hum Genet*, 2005). In the present study ultrasonic communication and social behaviors were assessed in SERT knockout rats. Rats lacking SERT were found to display reduced social approach behavior when exposed to playback of pro-social 50-kHz USVs. While wildtype and heterozygous littermate controls showed high levels of social approach behavior, social approach displayed by SERT knockout rats was reduced by 20-30% of controls. The reduced level of social approach behavior found in SERT knockout rats was paralleled by a complete lack of USV emission in response to playback. This is in stark contrast to wildtype and heterozygous littermate controls, of which both emitted high numbers of USVs when exposed to pro-social 50-kHz USVs. The lack of USV emission in SERT knockout rats appears to be specific for the social context of the playback experiment, as rats lacking SERT were found to emit high rates of 50-kHz USVs when exposed to novel environments or in response to amphetamine. While genotypes did not differ in amphetamine-induced hyperlocomotion, SERT knockout rats emitted more amphetamine-induced 50-kHz USVs than controls. Together, the present findings show that SERT plays an important role in ultrasonic communication and social behaviors.

Cortical hyperconnectivity associated with overexposure to 5-HT during brain development.

Stephanie Miceli¹, Martijn Selten¹, Moritz Negwer¹, Judith Homberg¹, Dirk Schubert¹

¹Donders Institute for Brain, Cognition and Behaviour, Department of Cognitive Neuroscience, Postbus 9101, 6500 HB Nijmegen, Netherlands

Serotonin (5-HT) guides neuronal migration during early cortical development and growing thalamocortical afferents transiently express the serotonin transporter (5-HTT). In rodents, blockage of 5-HTT function leads to high serotonin levels which results in reduced and diffuse thalamocortical projections towards the primary somatosensory (barrel) cortex. In our rat 5-HTT knockout model we investigated changes in cortical microcircuitry as a result of increased 5-HT levels during critical neurodevelopmental periods. Signal transmission across cortical layers of the barrel cortex *in-vitro* was analyzed using a combination of Multi-Electrode-Array (MEA) and whole-cell patch clamp recordings. The data indicated an increase in signal propagation associated with a higher number of synapses in the associative supragranular layers II/III. Functionally, whereas a decrease in somatosensory afferent input could lead to sensory discrimination deficits, the observed intra-cortical hyperconnectivity might represent a compensatory mechanism for such reduced input.

Behavioral and neurochemical consequences of subtle reduction in central serotonin production in mice

Valentina Mosienko¹, Susann Matthes¹, Daniel Beis¹, Michael Bader¹, Natalia Alenina¹

¹Max-Delbrueck-Center for Molecular Medicine, Molecular Biology of Peptide Hormones, Robert-Roessle str 10, 13125 Berlin, Germany

Since a long time serotonin is believed to be associated with anxiety and depression traits in humans. The most frequently prescribed antidepressants target the serotonergic system. Moreover, since the discovery of a rate-limiting enzyme of serotonin synthesis in the brain, tryptophan hydroxylase 2 (*TPH2*), lots of studies tried to link certain polymorphisms in *TPH2* with decreased serotonin production and abnormal behavior. However, the question whether or not certain polymorphism will lead to a reduction in central serotonin that in turn could influence specific behaviors remains unsolved. In order to address these questions we created three mouse models with a partial reduction in *TPH2* activity.

The first model is a congenic mouse carrying the *Tph2* C1473G polymorphism on C57Bl/6 genetic background (*Tph2*^{G/G}), which leads to the substitution of the aminoacid Pro447 by Arg447 and a subsequent reduction in *TPH2* activity. This polymorphism was discovered between the C57Bl/6 (1473C allele) and DBA (1473G allele) mouse strains and was suggested to be responsible for behavioral differences between these strains. The second model is a mouse on C57Bl/6 genetic background heterozygous for the *Tph2*-null allele (*Tph2*^{+/-} or *Tph2*^{C/-}). And the third model is a mouse carrying one *Tph2*-null allele and one 1473G allele (*Tph2*^{G/-}) obtained by crossing *Tph2*^{G/G} mice with *Tph2*-deficient mice (*Tph2*^{-/-}) on C57Bl/6 genetic background.

At first we assessed anxiety - and depression -like behavior in these mouse models. Surprisingly, *Tph2*^{G/G}, *Tph2*^{C/-}, and *Tph2*^{G/-} mice did not differ from C57Bl/6 control mice (*Tph2*^{C/C}) in elevated plus maze, marble burying test, and novelty suppressed feeding, as well as in the forced swim test pointing to normal anxiety- and depression-like behavior.

Next to elucidate if a reduction in *TPH2* activity affects serotonin turnover *in vivo*, we evaluated serotonin synthesis rates by HPLC measurement of 5-HTP accumulation after pharmacological inhibition of its further conversion to 5-HT. *Tph2*^{G/G}, *Tph2*^{C/-} and *Tph2*^{G/-} mice exhibited around 33, 19, and 59% reduction in brain serotonin synthesis in comparison to C57Bl/6 animals, leading to a subsequent 9, 13, and 19% lowering in brain serotonin level, respectively. This difference between serotonin synthesis and content may arise from reduced serotonin turnover, observed in *Tph2*^{G/G}, *Tph2*^{C/-} and *Tph2*^{G/-} mice. Furthermore, acute tryptophan injection could restore the serotonin content in *Tph2*^{G/G}, *Tph2*^{C/-}, but not in *Tph2*^{G/-} mice to the level of control. In addition, 5-HT_{1A} receptor function, evaluated by body temperature measurement after acute 5-HT_{1A} agonist 8-OH-DPAT treatment, was enhanced in *Tph2*^{G/G} and *Tph2*^{G/-} mice.

Our data suggest that a partial reduction in *TPH2* activity as well as a subtle depletion in brain serotonin does not change emotional behavior in mice most likely due to compensatory mechanisms including reduced serotonin metabolism and increased 5-HT_{1A} receptor sensitivity.

Symposium

S12: Cytoskeletal dynamics in neuronal migration

- S12-1** Neuronal migration illuminated: a look under the hood of the living neuron
David Joseph Solecki

- S12-2** Imaging of neuronal migration in zebrafish
Reinhard Wolfgang Koester

- S12-3** The ADF/cofilin family of actin binding proteins in neuronal migration and cortical development
Walter Witke, Melanie Schütz, Kathrin Bläsius, Christine Gurniak

- S12-4** Reelin-induced cofilin phosphorylation stabilizes the actin cytoskeleton during the migration of cortical neurons
Michael Frotscher

- S12-5** The actin-binding protein profilin1 in glial cell binding and radial migration of cerebellar granule neurons
Marco Rust

Neuronal migration illuminated: a look under the hood of the living neuron

David Joseph Solecki¹

¹St. Jude Children's Research Hospital, Developmental Neurobiology, 262 Danny Thomas Place, 38105 Memphis, USA

During vertebrate brain development, migration of neurons from the germinal zones to their final laminar positions is essential to establish functional neural circuits. Whereas key insights into neuronal migration initially came from landmark studies identifying the genes mutated in human cortical malformations, cell biology and state of the art time lapse microscopy has recently expanded our understanding of how cytoskeletal proteins and molecular motors drive the morphogenic cell movements that build the developing brain. The work from a variety of laboratories suggests the neurons migrate with a two-stroke cadence where the centrosome or cytoplasmic organelles move toward the direction of migration before somal translocation that ultimately has served as an excellent model to explore cytoskeletal function in migrating neurons throughout the CNS. Recently, we have identified the proximal portion of the cerebellar granule neuron leading process a region possessing high acto-myosin contractility necessary for centrosomal and somal translocation during nucleokinesis. I will present the latest results from my laboratory further examining leading process acto-myosin and highlight its role in positioning the golgi complex, primary cilia and regulating leading process adhesion during nucleokinesis.

Imaging of neuronal migration in zebrafish

Reinhard Wolfgang Koester¹

¹TU Braunschweig, Zoological Institute, Spielmannstrasse 7, 38106 Braunschweig, Germany

The coordinated migration of immature neurons to their final location of function is a crucial step during brain differentiation. In the cerebellum such prominent migration ensures the formation of neuronal layers and thus proper neuronal wiring and function. Neuronal migration can be directly observed in the transparent zebrafish embryo in order to understand cellular and molecular mechanisms that orchestrate the migration of neurons.

By analyzing different GFP-expressing transgenic zebrafish strains we have revealed the time course and pathways of migration for different cerebellar neuronal populations. As an example granule cell migration will be presented which occurs in a glia independent manner by the formation of chain-like structures among migrating neurons. Migration is cohesive and directional - migratory properties that are lost upon depletion of N-Cadherin expression. The lack of cohesive migration can be explained by the loss of adherens junctions. Directional migration though seems to be guided by a coupling of leading process and centrosome movements, which is lost upon impaired N-Cadherin expression. Imaging of N-Cadherin itself reveals a dynamic transport of this adhesion factor along the membrane of migrating granule cells that correlates with centrosome positioning. This oriented transport of N-Cadherin can thus guide directional migration.

To further analyze the subcellular coordination of neuronal migration we have generated Gal4 activator constructs that allow for efficient transgene activation in a rhombic lip specific manner. In addition, multi-cistronic Gal4-effector constructs enable different organelles to be monitored simultaneously in living zebrafish embryos. When rhombic lip-derived migration is revisited at the subcellular level several surprising findings were revealed: Based on cell movements to and along the midbrain-hindbrain boundary, rhombic lip-derived migration was initially classified as a two-phase migration. Now organelle dynamics show that the first phase represents extended proliferation movements rather than true rhombic lip disconnected cell migration. Nucleokinetic migration in vivo does not involve a strictly leading centrosome, instead the centrosome iteratively moves around the nucleus - reminiscent of Cadherin-2 dynamics - to the cell front where it is regularly overturned by the nucleus, questioning some of the current models of nucleokinesis. Finally, axonogenesis is observed to occur simultaneously to migration at a distance to the centrosome differing from in vitro findings in which the proximity to the centrosome determines filopodia to initiate axonogenesis. Thus in vivo cell biological analysis of neuronal migration reveals important insights into the cellular mechanisms and subcellular coordination of cellular dynamics.

The ADF/cofilin family of actin binding proteins in neuronal migration and cortical development

Walter Witke¹, Melanie Schütz¹, Kathrin Bläsius¹, Christine Gurniak¹

¹University Bonn, Institute of Genetics, Karlrobert-Kreiten 13, 53115 Bonn, Germany

Neuronal Migration is a key feature during brain morphogenesis and defects can result in severe neurological disorders. We will present data on the essential functions of the ADF/cofilin family in brain and particular in cortical development. We had previously shown that deletion of cofilin1 in mouse brain results in a lissencephaly-like phenotype and here we will provide information on the mechanisms of cortical neuron migration in the mutant animals. Using conditional mutagenesis in the mouse we will dissect the neuronal and glia based contribution of ADF/cofilin in cortical development. Cell culture experiments will complement these studies to elucidate the mechanisms of ADF/cofilin function during neuronal migration.

Reelin-induced cofilin phosphorylation stabilizes the actin cytoskeleton during the migration of cortical neurons

Michael Frotscher¹

¹Center for Molecular Neurobiology Hamburg (ZMNH), Institute for Structural Neurobiology, Falkenried 94, 20251 Hamburg, Germany

Reelin is a large glycoprotein of the extracellular matrix known to be involved in the radial migration of cortical neurons. In reeler mutants deficient in Reelin, the migration of neurons in the neocortex, hippocampus and cerebellum is severely altered, but the precise mechanism of Reelin's function in the migratory process remains to be elucidated.

We have recently provided evidence for Reelin being involved in the phosphorylation of cofilin, an actin-associated protein. Cofilin depolymerizes F-actin and thus participates in the reorganization of the actin cytoskeleton. Reorganization of the actin cytoskeleton is required for changes in cell shape and is involved in migratory activity and process growth. Phosphorylation of cofilin at serine3 renders it unable to depolymerize F-actin, thereby stabilizing the cytoskeleton. Previous studies have shown that stabilization of the leading processes of migrating neurons is required for their proper migration by nuclear translocation in the terminal phase of the migratory process. By means of cofilin phosphorylation Reelin synthesized and secreted by Cajal-Retzius cells in the marginal zone is likely to stabilize the tips of the leading processes of migrating cortical neurons, future apical dendrites of pyramidal cells. In fact, we show that Reelin is colocalized with phosphorylated cofilin (p-cofilin) in the marginal zone of neocortex and hippocampus. In reeler mutants p-cofilin is significantly reduced in the marginal zone. Hence, the leading processes of migrating neurons are not anchored to the marginal zone by cytoskeletal stabilization but are oriented in various directions. Indeed, previous Golgi studies have shown that the apical dendrites of pyramidal neurons in the reeler mutant do not show their normal, characteristic vertical orientation but run in various directions, often towards the white matter. Defect attachment of the leading processes to the marginal zone is likely to be a major reason for the inability of late-generated superficial neurons to pass by their predecessors. Supportive evidence for this hypothesis comes from our recent in utero electroporation experiments. We transfected postmitotic neurons in the cerebral cortex of mouse embryos with different constructs of cofilin, including point mutations at serine3, which resulted in a loss of neuronal polarization and impaired migration. Together our findings underscore a significant role of Reelin-induced cofilin phosphorylation for cytoskeletal stabilization, particularly of the leading processes, and for correct neuronal migration and positioning.

(Supported by the DFG: FR 620/12-1)

The actin-binding protein profilin1 in glial cell binding and radial migration of cerebellar granule neurons

Marco Rust¹

¹University of Kaiserslautern, Neurobiology/Neurophysiology Group, Erwin-Schrödinger Strasse 13, 67663 Kaiserslautern, Germany

Migration of neurons along radial glial cells is essential for the lamination of cortical structures in higher vertebrates. Cerebellar granule neurons (CGN) exploit fibers of Bergmann glia (BG) for radial migration from the external to the internal granule cell layer. Cell-cell contacts play a pivotal role in this process, however little is known about the mechanisms that control CGN-BG interaction. Here we demonstrate that the actin-binding protein profilin1 in CGN and in BG is essential for glial cell binding and radial migration. Our data suggest that profilin1 regulates neuron-glia interaction through a mechanism that also involves vinculin and mena. Genetic ablation of profilin1 in the mouse brain leads to cerebellar hypoplasia, aberrant organization of the cerebellar cortex layers, and CGN misplacement. Our results show the critical importance of profilin1 for neuron-glia interaction and radial migration. Conversely, proliferation of neuronal progenitors, tangential migration of neurons, and BG organization are independent of profilin1 function.

Symposium

S13: Olfactory learning: from insects to machines

- S13-1** Circuits for memory formation in the fly brain
Hiromu Tanimoto
- S13-2** Dynamics of olfactory memory acquisition in *Drosophila melanogaster*
Lisa Scheunemann, Christian Hundsrücker, Enno Klussmann, Marina Efetova, Martin Schwärzel
- S13-3** Encoding of odor-reward association in single mushroom body output neurons correlates with behavioral performance
Martin Fritz Strube-Bloss
- S13-4** A computational model of fast associative learning in the honeybee
Joachim Haenicke, Evren Pamir, Martin Paul Nawrot
- S13-5** Behavioral and genetic basis of thermal aversive conditioning in honeybees
Pierre Junca, Julie Carcaud, Sibyle Moulin, Lionel Garnery, Jean-Christophe Sandoz
- S13-6** Issues for robot models of olfactory learning in insects
Barbara Webb, Jan Wessnitzer, Jonas Klein, Joanna M. Young
- S13-7** On the equivalence of the insect brain and artificial intelligence for pattern recognition
Ramon Huerta

Circuits for memory formation in the fly brain

Hiromu Tanimoto¹

¹Max-Planck-Institut fuer Neurobiologie, Verhaltensgenetik, Am Klopferspitz 18, 82152 Martinsried, Germany

Animals can adapt their behaviour to given environment according to memories of their former experiences. To address neural circuits underlying adaptive behaviour, we chose associative memory of *Drosophila melanogaster* as a model system. Flies form positive or negative memories of an odour by paired presentation of sugar reward or electric shock punishment. Over the past years, we have worked on the neuronal mechanisms that endow positive or negative values with the odour and found the important roles of neuromodulator dopamine. The value signals by dopamine converge with the odour signal in the mushroom body that consists of second-order olfactory interneurons, thereby the fly forms associative memories. Since dopamine is synthesized in ~280 neurons in the fly brain and involved also in other brain functions, it is important to identify individual responsible neurons for value signalling. I will summarize our most recent findings particularly how we identified different types of neurons for signalling positive and negative values and discuss about the subcellular modulation of synapses at the formation of memories.

Dynamics of olfactory memory acquisition in *Drosophila melanogaster*

Lisa Scheunemann¹, Christian Hundsrücker², Enno Klussmann², Marina Efetova¹,
Martin Schwärzel¹

¹Free University of Berlin, Neurogenetic, Takustr. 6, 14195 Berlin, Germany

²Leibniz-Institut für Molekulare Pharmakologie, Campus Berlin-Buch, Robert-Rössle-Str. 10, 13125 Berlin, Germany

Defining the molecular and neuronal basis of associative memories is based upon behavioral preparations that are critically tuned to yield high memory performance. For sake of that goal behavioral paradigms tend to overtrain by selecting for salient stimuli, strong reinforcement and repeated conditioning trials. One well established paradigm is *Drosophila* aversive olfactory conditioning, where animals experience a total of 12 iterations of high electric current administered during one minute of odor exposure to complete one pavlovian training cycle. This “standard” training has been successfully used since 1985 and it is sufficient to initiate immediate short-term memory (STM), consolidated anesthesia-resistant memory (ARM) and labile anesthesia-sensitive memory (ASM) in wild type animals. Here, we show that acquisition of STM, ASM and ARM are separate processes critically determined by iteration and intensity of individual punishing events. We show that STM acquires in a graded fashion by accumulation of shock iteration and intensity. In contrast, acquisition of ARM is a singular process while ASM acquires via a characteristic two-step mechanism. At the molecular level we identified A-Kinase-Anchoring-Proteins (AKAPs) at level of Kenyon cells as critical component for support of ASM. We provide a list of 80 potential AKAPs in the fruit fly to serve as road map towards identifying particular AKAPs involved in memory processing.

Encoding of odor-reward association in single mushroom body output neurons correlates with behavioral performance

Martin Fritz Strube-Bloss¹

¹Max Plank Institute for Chemical Ecology, Department of Evolutionary Neuroethology, Hans-Knoell Strasse 8, 07745 Jena, Germany

Neural representations of odors are subject to computations that involve convergent and divergent anatomical feed forward connections across different areas of the brains, in both mammals and insects. In addition, higher order brain areas send recurrent feedback to the first order neuropiles. In the honey bee, about eight hundred Projection Neuron (PN) axons from the primary olfactory processing center, the Antennal Lobe (AL), make divergent connections to more than one hundred thousand Mushroom Body (MB) intrinsic neurons, the Kenyon Cells (KC). This, sparsely distributed information then converges onto only a few hundred Extrinsic Neurons (EN). Most ENs provide MB output to different brain areas. Some ENs project to the contra lateral MB other ENs, related to the centrifugal system, provide feedback connections to the AL.

We studied the neural representation of odors across different processing levels (Strube-Bloss, Herrera-Valdez & Smith, in review) and the encoding of odor-reward associations at the level of the MB output (Strube-Bloss, Nawrot & Menzel, 2011). In naive animals we simultaneously recorded the single neuron AL and MB output. We found that odor stimuli were equally well classifiable by both ensembles. Surprisingly, the EN ensemble developed significant odor classification 24-60ms before the PN ensemble significantly separates the odor stimuli. Furthermore, maximal odor separation in both ensembles was 26-133ms apart, where the PNs always followed the ENs. Thus, the timing of the EN ensemble activity would allow retroactive integration of its output signal into the ongoing computation of the AL via its feedback projections.

In classical conditioning experiments we found that retrieval of a stored memory has an effect on the timing of the EN population response. During the retention tests 3 hours after conditioning EN activity in response to the reward associated odor (CS+) was prolonged and reached its maximum population activity at the same time at which the AL population response reaches maximum odor separation. This time shift of EN peak activity goes along with a drastic peak rate increase in ENs only for the reward associated odor stimulus. We hypothesize that, during retention of a stored memory, both neuropiles become coupled and compute at the same timescale.

At the single EN level, neuronal plasticity is expressed only after a 3h consolidation phase but not during acquisition. Interestingly, the associative strength represented at the single neuron level is highly correlated with the performance during memory retention in individual animals (Strube-Bloss, D'Albis & Nawrot, in prep). During retention, we found a strong correlation between an animal's individual behavioral performance and a quantitative measure of learning at the single neuron level. We conclude that the population of MB output neurons encode the value associated with a very specific odor stimulus and predicts the potential reward that could be gained through appropriate action.

References:

Strube-Bloss MF, Nawrot MP, Menzel R (2011) Mushroom body output neurons encode odor-reward associations. *The Journal of Neuroscience* 31: 3129–3140.

Strube-Bloss MF, Herrera-Valdez MA, Smith BH (under review) Ensemble response in mushroom body output neurons of the honey bee outpaces spatiotemporal odor processing two synapses earlier in the antennal lobe. PLoS ONE.

Strube-Bloss MF, D'Albis T, Nawrot MP (in prep) Single cell responses correlate to the behavioral expression of a classical conditioned memory in individual honeybees

A computational model of fast associative learning in the honeybee

Joachim Haenicke^{1,2}, Evren Pamir^{1,2}, Martin Paul Nawrot^{1,2}

¹Bernstein Center for Computational Neuroscience Berlin, Germany

²Freie Universität Berlin, Theoretical Neuroscience / Neuroinformatics, Königin-Luise-Str. 1-3, 14195 Berlin, Germany

Numerous experimental studies on classical conditioning in the honeybee *Apis mellifera* have provided insights into the physiological processes of olfactory learning and memory formation. On the basis of these findings, several theoretical studies have proposed different model hypotheses for sensory processing and learning in the insect brain. However, the actual dynamics of associative learning as evident from behavior in individual animals is typically neglected. For the honeybee, recent analyses suggest that individual animals learn to associate between odor and sugar reward typically within a single trial and subsequently show a stable conditioned response during training and memory retention (Pamir et al. 2011, Learning & memory).

Here, we present a computational model approach at the spiking neuronal network level which allows us to mimic a number of different experimental protocols during classical conditioning of the proboscis extension response in the honeybee. We implement and compare different hypotheses on physiological mechanisms that support fast associative learning by evaluating their ability to reproduce both behavioral and physiological constraints as observed in experiments. The behavioral constraints of our model are defined by the learning performance of individual animals during various conditioning paradigms (e.g. absolute, differential, backward, delay, trace and massed conditioning, negative patterning). Physiological constraints comprise recordings of neuronal activity from different processing stages along the sensory-to-motor pathway.

Behavioral and genetic basis of thermal aversive conditioning in honeybees

Pierre Junca¹, Julie Carcaud¹, Sibyle Moulin¹, Lionel Garnery¹, Jean-Christophe Sandoz¹

¹CNRS, LEGS (Laboratoire Evolution, Génome et Spéciation), avenue de la terrasse, 91198 Gif-sur-Yvette, France

In the wild, animals learn to associate initially neutral sensory stimuli (color, odor, etc.) with positive (e.g. food) or negative (e.g. danger) consequences and perform appetitive and aversive learning, respectively. The honeybee (*Apis mellifera*) is an invertebrate model commonly used in the laboratory for studying olfactory learning and memory. Until recently, research almost exclusively focused on olfactory appetitive learning, using the protocol for conditioning the proboscis extension response (PER), in which bees learn to associate an odor (conditioned stimulus - CS) with a sucrose reward (unconditioned stimulus - US). A few years ago, a new aversive learning protocol was developed. In the conditioning of the sting extension response (SER), bees learn to associate an odor (CS) with an electric shock (US). One drawback of using an electric shock as US is that it is not a natural aversive stimulus for bees and that it is difficult to pinpoint exactly which part of the bee's body has been stimulated. It is therefore difficult to precisely identify the peripheral receptors involved in the detection of this US. We thus aimed to provide a more natural and controllable US for studying aversive SER conditioning and building a comprehensive model of the neural pathways involved in this conditioning.

Here, we tested the use of a small heated probe that could be applied locally to different body parts. We show that stimulation of most regions of the bee body with heat elicits the SER, while tactile stimulation only does not. We next studied the responsiveness of chosen structures (antennae, mouthparts and forelegs) to increasing temperature. In all three tested structures, an increasing number of bees responded with SER when temperature increased. Similar temperature/response relationships were observed in the three structures. We then asked whether heat can be used as US in a SER conditioning protocol. We thus performed differential conditioning with two odors, one being punished with heat on one of the three structures, the other odor being presented without punishment. We found that bees can associate an odor with the thermal stimulus when heat is applied to the antennae, to the mouthparts or to the legs. Thus heat can be used as an efficient US in the SER conditioning protocol. This new aversive conditioning using local application of a thermal stimulus will enable us to more precisely study the neuronal basis underlying the aversive conditioning in bees.

Honeybees are also good experimental model for studying the impact of genetic variations on learning and memory. A queen bee usually mates with 15-20 drones, so that her worker offsprings belong to as many different patriline. Using microsatellite analysis, we analyzed heat sensitivity and aversive learning performances in worker patriline issued from a naturally-inseminated queen. First, we found that heat responsiveness is closely correlated with SER learning performance: the more sensitive a worker is to the heat US, the better it learns an aversive association with this US. We also found that some patriline were more heat sensitive and also better aversive learners than others, showing a clear genetic basis for aversive responsiveness and learning. Future work will compare aversive and appetitive conditioning in the same patriline to understand whether both types of learning depend on the same or on a different genetic basis.

Issues for robot models of olfactory learning in insects

Barbara Webb¹, Jan Wessnitzer¹, Jonas Klein¹, Joanna M. Young¹

¹University of Edinburgh, School of Informatics, 10 Crichton St, EH8 9AB Edinburgh, United Kingdom

Implementing biologically inspired algorithms on a robot allows them to be tested in the context of controlling real behaviour in the world. The neural circuit of olfactory learning in insects is increasingly well understood and has been modelled in some detail. Both neurophysiological investigations and neurocomputational models have focussed on the conditioned and unconditioned stimulus pathways, and how their convergence in the mushroom bodies can lead to altered activity in extrinsic neurons. Synaptic changes, which depend on the coincidence of presynaptic activity and biological amine release, and may also involve spike timing dependent plasticity, can potentially encode memories for patterns of activity evoked by odours and odour combinations. However, there remains a gap in accounting for the actual change in behaviour that constitutes learning. For example, we have found that the ability of a simulated mushroom body neural architecture to learn non-elemental tasks exceeds the actual behaviour of flies trained on the same tasks [1,2]. By investigating a spiking neural circuit that controls the behaviour of a robot, we gain insights into some of the remaining issues. Why does classical conditioning produce specific behaviours? Does the conditioned stimulus now predict the unconditioned stimulus, or has a direct connection between the conditioned stimulus and behaviour been strengthened? How does sensory pre-processing shape learning? How does ongoing behaviour affect the temporal dynamics of encountering stimulus and reinforcer? What is the moment by moment change in behavioural control that underlies learning scores? How is the expression of learnt behaviour affected by motivational states and the current environmental context?

1. Wessnitzer, J., Young, J., Armstrong, D. & Webb, B. (2011) A model of non-elemental olfactory learning in *Drosophila*. *Journal of Computational Neuroscience* 32:197-212
2. Young, J., Wessnitzer, J., Armstrong, D.A. & Webb, B. (2011) Elemental and non-elemental olfactory learning in *Drosophila*. *Neurobiology of Learning and Memory* 96:339-352

On the equivalence of the insect brain and artificial intelligence for pattern recognition

Ramon Huerta¹

¹University of California San Diego, BioCircuits Institute, 9500 Gilman Dr, 92101 San Diego, USA

In the course of evolution animals, bacteria and plants have developed sophisticated methods and algorithms for solving difficult problems in chemical sensing very efficiently. Complex signalling pathways inside single cells can trigger movement toward the source of a nutrient. Complex networks of neurons are able to compute odor types and the distance to a source in turbulent flows. These networks of neurons use a combination of temporal coding, layered structures, simple Hebbian learning rules, reinforcement learning and inhibition to quickly learn about chemical stimuli that are critical for their survival.

In this talk we revisit the critical elements of the insect brain involved in odor discrimination and determine the impact that each of the areas have in learning an odor discrimination task. We apply these lessons to the problem of gas identification with artificial sensor arrays. The insect brain must cope with those conditions by preprocessing the data using the excitatory-inhibitory network in the first relay station of the insect olfactory system. It manages to extract and dynamically inhibit common odor representation and enhances the sensitivity to novel ones. Thus, we use the insect olfactory system as a base and inspiration to build odor recognition devices that take advantage of the spatio-temporal characteristics of the turbulent gas plume. We demonstrate how they can be merged and compared to state-of-the-art machine learning algorithms.

Symposium

S14: Molecular Mechanisms and Spreading of alpha-synuclein pathology in the brain

- S14-1** alpha-synuclein regulates dopamine neurotransmission specifically in susceptible neuronal populations: the key to Parkinson's pathophysiology?
Richard Wade-Martins
- S14-2** Autophagy and alpha-synuclein aggregation
Jochen Klucken
- S14-3** Alpha-synuclein oligomerization and neuronal dysfunction: intracellular and extracellular effects
Tiago Fleming Outeiro
- S14-4** Investigation of the mechanisms of a-synuclein secretion in vivo
KOSTAS VEKRELLIS, EVANGELIA EMMANOUILIDOU, GEORGIA MINAKAKI, MARIA KERAMIOTI
- S14-5** Long-distance trafficking of Parkinson pathology in neurons
Jia-Yi Li
- S14-6** LRRK2 interacts with a-synuclein and tau and is present in Lewy bodies in Parkinson's disease
Patricia Silva Guerreiro, Yue Huang, Glenda Halliday, Tiago Outeiro

alpha-synuclein regulates dopamine neurotransmission specifically in susceptible neuronal populations: the key to Parkinson's pathophysiology?

Richard Wade-Martins¹

¹University of Oxford, Oxford Parkinson's Disease Centre, Department of Physiology, Anatomy and Genetics, South Parks Road, OX1 3QX Oxford, United Kingdom

There is increasing evidence that the critical early and therapeutically -tractable phase of neurodegenerative disease involves deficits in synaptic function before the appearance of protein aggregates. Our work to understand the earliest pathways to pathology in Parkinson's disease (PD) focuses therefore not on protein aggregation, but on studying changes in cellular physiology and neurotransmission in dopaminergic and non-dopaminergic systems which precede pathology.

To better understand the sequence of events which occur in PD we have created BAC transgenic mice (SNCA-OVX) which express wild-type human alpha-synuclein from the complete human wild-type SNCA locus at ~2 -fold increased levels compared to endogenous to model the molecular mechanisms associated with familial and sporadic PD. The SNCA -OVX mice were crossed onto the *Snc*a-/- background to avoid the confounding effect of expressing mouse alpha-synuclein. The SNCA-OVX mice display a transgene expression profile which accurately recapitulates that of endogenous mouse alpha-synuclein, including expression in the substantia nigra, ventral tegmental area, cortex and hippocampus. SNCA-OVX mice exhibit a sustained deficit in dopamine release from a young age in the dorsal but not ventral striatum as measured by fast-scan cyclic voltametry, thereby mirroring the regional selective susceptibility in PD patients. The deficit was specific to dopamine transmission as there were no changes in transmission of the monoamines serotonin or noradrenaline. The SNCA-OVX mice develop vesicle disorganisation in dopaminergic terminals in the striatum which we propose to reflect altered distribution of pre-synaptic vesicular pools. The SNCA-OVX mice showed early changes in gastro-intestinal function, late-onset motor impairments and an age-dependent loss of nigrostriatal dopaminergic neurons. Finally, we have shown the SNCA -OVX mice to have a reduced *in vivo* dopaminergic neuron firing frequency at old, but not young, age. We propose the SNCA-OVX mice model the temporal events of PD and allow us to better understand the complexity of this late-onset disease.

The results from our novel SNCA-OVX mice are conversely reminiscent of our previous work in synuclein knock-out mice. In our previous work our laboratory has shown that mice null for alpha-, beta- and gamma-synuclein, or for alpha - and gamma -synuclein, displayed increased dopaminergic neurotransmission specifically in the dorsal, but not ventral, striatum and that synuclein may negatively regulate striatal dopamine release. Elevated dopamine release was accompanied by a decrease of dopamine tissue content specifically in the dorsal striatum.

The pathological end-state of Parkinson's disease is well-described from post-mortem tissue, but the earliest changes in the physiology of susceptible neurons remain unclear. Overall our findings in two highly complementary models, the SNCA-OVX transgenic mouse, and combinatorial synuclein knock-out mice, uniquely reveal the importance of alpha -synuclein in regulating neurotransmitter release from specific populations of midbrain dopamine neurons. Our findings that alpha-synuclein regulates dopamine handling by presynaptic terminals specifically in those regions preferentially vulnerable in Parkinson's disease (PD) may ultimately inform on the selectivity of the disease process.

Autophagy and alpha-synuclein aggregation

Jochen Klucken¹

¹University Hospital Erlangen, Department of Molecular Neurology, Schwabachanlage 6, 91054 Erlangen, Germany

Synucleinopathies such as Parkinson's disease (PD) and Dementia with Lewy Bodies (DLB) are characterized by intraneuronal alpha-synuclein aggregates (Lewy bodies or neurites). Even though mutations of the alpha-synuclein gene have been linked to PD, the pathological relevance of alpha-synuclein aggregates is still controversial. Autophagy of intracellular proteins plays an important role in age-related disease of the central nervous system such as PD. Increasing evidence links autophagy mediated degradation of proteins and intracellular organelles to the underlying molecular mechanisms of PD. Alpha-synuclein oligomers or aggregates are degraded by autophagy. More recently, we were able to show that autophagy modulation affects alpha-synuclein aggregation. Using both human post mortem and combined in vitro/vivo analysis we suggest that this process may include both aggregate formation and secretion of alpha-synuclein species. Induction of intracellular autophagy mechanisms may be protective for the individual cell, but toxic for the microenvironment by released distinct synuclein species. Our results indicate that autophagy is not only relevant for protein degradation, but also influences aggregation and secretion of distinct alpha-synuclein species thereby potentially contributing to the propagation of the aggregation process in PD and DLB.

Alpha-synuclein oligomerization and neuronal dysfunction: intracellular and extracellular effects

Tiago Fleming Outeiro¹

¹University Medical Center Goettingen, Department of Neurodegeneration and Restorative Research, Waldweg 33, 37073 Goettingen, Germany

Parkinson's disease is the most common representative of a group of disorders known as synucleinopathies, in which misfolding and aggregation of alpha-synuclein (a-syn) in various brain regions is the major pathological hallmark. Here, we conducted an RNAi-based genetic screen to identify novel modifiers of a-syn oligomerization in living cells, a step that precedes the formation of larger Lewy-body like inclusions. We found that genes involved in trafficking and in signalling pathways are potent modulators of a-syn oligomerization. In addition, we investigated the impact of different a-syn species (monomers, oligomers, and fibrils) on readouts of synaptic transmission and plasticity. We found that a-syn oligomeric species, but not monomers or fibrils, caused an enhancement of synaptic transmission and impairment of long-term potentiation in Schaffer-collaterals/CA1 connections through a mechanism dependent on NMDA receptor activation. Moreover, a-syn oligomers caused an increase in synaptic calcium-permeable AMPA receptor expression. Since excitotoxicity is implicated in neurodegeneration, our findings shed light into the mechanisms through which specific forms of a-syn may trigger neuronal dysfunction and therefore enable the development of novel strategies for therapeutic intervention.

Investigation of the mechanisms of α -synuclein secretion in vivo

KOSTAS VEKRELLIS¹, EVANGELIA EMMANOUILIDOU¹, GEORGIA MINAKAKI¹,
MARIA KERAMIOTI¹

¹BIOMEDICAL RESEARCH FOUNDATION ACADEMY OF ATHENS, BASIC NEUROSCIENCES, SORANOU EFESIOU 4,
11527 ATHENS, Greece

Objective: To elucidate the mechanism(s) that regulate the secretion of α -synuclein in vivo, we have pharmacologically manipulated α -synuclein release in mouse brain by locally applying reagents that target intracellular calcium concentration, ATP-binding cassette (ABC) transporter operation, and lysosome function.

Background: α -Synuclein is central in the pathogenesis of Parkinson's Disease (PD). Recent discoveries have suggested that α -synuclein can be directly transmitted from pathologically affected to healthy neurons, thereby supporting a role of extracellular α -synuclein in the pathological progression of PD. We have shown that in vitro α -synuclein is partially secreted via exosomes. Importantly, using an in vivo microdialysis approach in conjunction with a novel, ultra-sensitive ELISA, we have recently shown that α -synuclein is normally present in human and mouse brain parenchyma. This secretable form of α -synuclein may be biologically important, since it may act in a paracrine manner affecting neighboring cells.

Methods: Compounds were locally administered by reverse microdialysis in the striatum of freely moving A53T-synuclein expressing mice. The effects of these reagents were assessed by quantification of α -synuclein concentration in microdialysis fractions from the interstitial fluid (ISF) before and after the administration of the compound.

Results: KCl-induced membrane depolarization and thapsigargin, a potent inhibitor of the SERCA pump, resulted in a sharp and significant increase in ISF α -synuclein levels. Administration of glyburide, a selective sulfonylurea receptor 1 (SUR1)-blocker, caused a decrease in ISF α -synuclein concentration. Application chloroquine, which potentially perturbs membrane trafficking from endosomes to lysosomes, induced an increase of α -synuclein release.

Conclusions: Our data so far has shown that α -synuclein secretion is a process that can be stimulated by elevation of intracellular calcium concentration. Application of glyburide indicated that another type of SUR1-regulated channels, but probably not KATP channels, could be implicated in α -synuclein export. The endosomal pathway also seems to be involved in this process.

Long-distance trafficking of Parkinson pathology in neurons

Jia-Yi Li¹

¹Lund University, Wallenberg Neuroscience Center Department of Experimental Medical Science, BMC A10, 22184 Lund, Sweden

Earlier post-mortem analyses of brains from patients with Parkinson's disease who received fetal mesencephalic transplants showed that α -synuclein-containing Lewy bodies gradually appear in grafted neurons. We recently shown evidence of α -synuclein cell-to-cell transfer using in vitro and in vivo models of PD, indicating that intercellular transfer of α -synuclein from host to graft, followed by seeding of α -synuclein aggregation in recipient neurons, can contribute to the phenomenon in transplanted patients' brains.

Braak and co-workers have hypothesized that Lewy body pathology may be transmitted long-distance via the olfactory system or the enteric nervous system in the gastrointestinal tract by axonal transport. However, experimentally, the hypothesis has not been tested. Here we have performed a series of in vitro and in vivo experiments by injecting human α -synuclein and its aggregates in the sites of far away from a specific brain region or virally transduced human α -synuclein. We observed that human α -synuclein and its aggregating species can indeed transported long-distance. Further studies are ongoing to dissect the underlying mechanisms of the transport.

LRRK2 interacts with α -synuclein and tau and is present in Lewy bodies in Parkinson's disease

Patricia Silva Guerreiro¹, Yue Huang², Glenda Halliday², Tiago Outeiro^{1,3}

Cell and Molecular Neuroscience Unit, Instituto de Medicina Molecular, Lisboa, Portugal. ¹

Neuroscience Research Australia, Sydney, and The University of New South Wales, Sydney, Australia²

Department of NeuroDegeneration and Restorative Research, University Medizin Goettingen, Waldweg 33, 37073 Goettingen, Germany³

Leucine-rich repeat kinase 2 (LRRK2) mutations are the most common cause of inherited forms of Parkinson's disease (PD). The clinical features of PD cases associated with LRRK2 mutations are indistinguishable from idiopathic cases, with late onset and the accumulation of α -synuclein and/or Tau protein inclusions in the remaining neurons.

Here, we show that in PD brain tissue, the levels of LRRK2 are positively related to the increase in α -synuclein phosphorylation and aggregation in affected brain regions (amygdala and anterior cingulate cortex), but not in the unaffected visual cortex. In disease-affected regions, we show co-localization of these two proteins in neurons and Lewy bodies. Further in vitro experiments show a molecular interaction between wild-type α -synuclein and wild type LRRK2 under endogenous and over-expression conditions. In a cell culture model of Lewy body formation, LRRK2 was also co-localized with α -synuclein aggregates, and knocking down LRRK2 altered the aggregation pattern of α -synuclein. We also explore the interaction between LRRK2 and α -synuclein or Tau using bimolecular fluorescence complementation assays (BiFC).

Our results highlight the interaction between these proteins and shed light into the complex relationship between these proteins in the context of PD.

Symposium

S15: Cortical connectivity of crossmodal interactions

- S15-1** How changes in cortical crosstalk relate to differences in multisensory perception
Toemme Noesselt

- S15-2** Spatial selectivity of cortical rhythms
Verena Nadine Buchholz, Ole Jensen, W.Pieter Medendorp

- S15-3** Visual-somatosensory interaction for perception and action
Katja Fiehler

- S15-4** Predictive mechanisms and oscillatory organization: the case of audio-visual speech processing
Luc H. Arnal

- S15-5** Touch localization under coordinate conflict
Stephanie Badde, Tobias Heed, Brigitte Röder

- S15-6** Disentangling cross-modal top-down predictive control by actively manipulating arbitrarily learned associations
Abhilash Dwarakanath, Christoph Kayser

How changes in cortical crosstalk relate to differences in multisensory perception

Toemme Noesselt¹

¹Otto-von-Guericke-Universität, Institute of Biological Psychology, Universitätsplatz 1, 39106 Magdeburg, Germany

Events in the environment often stimulate more than one sense; thus integrating information across sensory inputs may improve the reliability of our representations of the environment. Previous imaging studies have highlighted numerous regions involved in multisensory integration, including the superior colliculi, multisensory cortical convergence zones, but also sensory-specific cortex and even sensory thalamus such as the lateral and medial geniculate (see e.g. Driver & Noesselt, 2008, for review). In this talk I will present results from a series of fMRI -studies, which investigated the neural networks instrumental in processing of audiovisual coincidence and of audiovisual looming, of sound-induced boosts of visual perception, and of touch-induced boosts of auditory perception:

The results of the first fMRI -study on audiovisual coincidence (Noesselt et al., 2007) indicate that a network of primary visual and auditory cortex plus the multisensory superior temporal sulcus (STS) are involved in the processing of audiovisual coincidence (relative to non-coincidence). Network-analyses (psychophysiological interactions and directed information transfer) suggest a higher information flow from STS to unisensory cortex, than vice versa. This accords with the notion of feedback modulation during audiovisual coincidence processing.

However, using fMRI and audiovisual looming and receding stimuli, with overall identical temporal information, we found that the network of primary visual and auditory cortex plus the STS is selectively modulated for looming relative to receding stimuli (Tyll et al., 2012). This pattern of results suggests that this unisensory-STS network is not only involved in coincidence processing, but rather indexes behavioral relevance.

In a third fMRI-experiment we investigated whether a task-irrelevant sound may enhance detection of near-threshold visual stimuli and its neural basis (Noesselt et al., 2010). Here, we found enhanced fMRI-signals in low-level visual and auditory cortex plus the STS which scaled with subjects' behavioral performance. Moreover, auditory and visual thalamus were also modulated. A PPI-analysis further indicated that auditory and visual thalamus were both effectively connected with lateral occipital areas and the STS and that the connection strength scaled with subject-specific behavioral performance. Further, preliminary EEG-results point to early integration effects in accord with integration at the level of the thalamus.

In a fourth fMRI-experiment we investigated audiotactile interplay instead (Höfer et al., under review). Task-irrelevant tactile stimuli enhanced auditory perception and enhanced fMRI-signals in low-level auditory and tactile cortex plus the STS. A PPI-network analysis again found enhanced connectivity between primary auditory cortex with STS and tactile regions. Connection strength scaled with subjects' behavioral performance.

Together, the results from our experiments indicate that the brain uses a network of unisensory and multisensory cortical areas (and sometimes the thalamus) to integrate information across senses. Importantly, the strength of these network connections (as measured with PPI) appears to be a valid predictor of subject-specific multisensory behavioral benefits.

Spatial selectivity of cortical rhythms

Verena Nadine Buchholz¹, Ole Jensen¹, W.Pieter Medendorp¹

¹Radboud University, Donders Institute for Brain, Cognition and Behaviour, Cognitive Psychology, Montessorilaan 3, 6525HR Nijmegen, Netherlands

Multisensory processing, sensorimotor integration and multimodal attention require spatial processing across different formats, as each modality has its natural reference frame. Visual input is encoded relative to the eyes, auditory input relative to the head and touch relative to the body. Oscillatory activity has been shown to support sensory and motor processes in specific frequency bands, but their reference frames have never been investigated. Using magnetoencephalography, we identified reference frames in oscillatory activity across the fronto-parietal network in the alpha (8-12 Hz), beta (16-32 Hz) and gamma band (>30 Hz) during sensorimotor tasks involving eye- and hand-movement to tactile stimuli. Gamma and alpha band activity reflected amplification in body- and eye-centered reference frames, depending on their cortical origin. In contrast, beta band activity showed body-centered (somatotopic) selectivity across the fronto-parietal network, including areas that showed eye-centered selectivity in other bands.

Visual-somatosensory interaction for perception and action

Katja Fiehler¹

¹Justus-Liebig-Universität Gießen, Experimental Psychology, Otto-Behaghel-Str. 10 F, 35394 Gießen, Germany

Visual perception and action are supposed to be implemented in two distinct cortical pathways. The dorsal pathway projects from primary visual areas to the posterior parietal cortex and processes visual information for space perception and movement guidance. The ventral pathway connects primary visual areas with the inferior temporal cortex and is central for object recognition. In everyday life, information from multiple senses such as vision, touch or audition usually contributes to both perception and action. As a consequence, the respective brain areas need to process and integrate input from multiple senses arising in different reference frames. In the talk, I will present studies where we aimed to (a) extend dorsal pathway functions to the somatosensory modality, (b) examine cross-modal (visual-somatosensory) recruitment of brain areas, and (c) test for optimal integration of visual and somatosensory information.

Using functional magnetic resonance imaging (fMRI) we investigated the neural correlates of somatosensory-guided movements. Participants were asked to perform hand movements on the basis of tactile and kinesthetic feedback and in the absence of vision. As expected, we found activation in the primary somatosensory cortex which varied with movement difficulty. In addition, we observed activation in the posterior parietal cortex, i.e. in brain areas along the dorsal pathway. Similar brain areas have been observed in previous studies on visually-guided hand movements suggesting a multisensory (at least visual-somatosensory) network of action control. In order to control for the possible confound that the observed dorsal stream areas were activated as a result of visual imagery of the corresponding hand movement we applied the same task in a group of congenitally blind people. Here, we found a similar activation pattern comprising areas along the dorsal stream. Our findings are consistent with the neuronal properties of the posterior parietal cortex which receives and integrates input from multiple sensory cortices and thus multiple reference frames.

The multisensory nature of the dorsal pathway may also allow for cross-modal information processing. In an fMRI study, we applied a visual-somatosensory delayed-matching-to-sample task where information was encoded in one modality and later compared with information from the other modality. In line with our previous findings, dorsal pathway structures seem to be significantly involved in the interplay of different senses for action and perception.

Electrophysiological studies in monkeys further suggest that when visual and somatosensory movement information is simultaneously available they are integrated in a statistical optimal way. In psychophysical experiments, we tested in humans whether the integration of visual and somatosensory path trajectories follow the Maximum-Likelihood-Estimation (MLE) model. Our results suggest that optimal integration of visual and somatosensory signals is task-dependent and only applies in some conditions.

Predictive mechanisms and oscillatory organization: the case of audio-visual speech processing

Luc H. Arnal¹

¹New York University, Department of Psychology, 6 Washington Place, room 275, 10003 New York, USA

Current theories of perception suggest that we continuously update an internal model of the world to infer the probable causes of sensory events. In face-to-face speech, our brain exploits the contingencies between speech sounds and their visible causes, i.e., orofacial movements, to predict our interlocutor's discourse. As mouth movements are typically formed before our vocal tract emits speech sounds, speech predictions can be generated on the sole basis of visual cues, and tested against the auditory input. In this presentation, I will argue that distinct oscillatory patterns reflect the utilization of visually based priors to optimize speech recognition and the revision of internal models if visual priors are misleading. I will further discuss how direct visuo-auditory connections contribute to predicting speech.

Touch localization under coordinate conflict

Stephanie Badde¹, Tobias Heed¹, Brigitte Röder¹

¹University of Hamburg, Biological Psychology and Neuropsychology, Von-Melle-Park 11, 20146 Hamburg, Germany

The location of a touch is initially encoded in anatomical coordinates. However, to integrate touch and visual information, touch has to be coded in an external-spatial reference frame.

An often used manipulation to investigate tactile remapping is hand crossing. In this posture, the right hand (anatomical coordinates) is located in the left hemispace (external coordinates). Consequently, the anatomical and external spatial coordinates of tactile stimuli applied to the hands are in conflict. Indeed, the ability to correctly report the temporal order of two successive tactile stimuli, one applied to each hand, is markedly reduced with crossed compared to uncrossed hands (Yamamoto & Kitazawa, 2001, Shore, Spry, & Spence, 2002, Röder, Rösler, & Spence, 2004).

However, the general validity of limb crossing as a measure of tactile remapping has been questioned because remapping might require additional processes to transfer information between the hemispheres (Azañón, Longo, Soto-Faraco, & Haggard, 2010). Similarly, it has been doubted, whether crossing effects generalize to tasks involving only one touch (Shore et al., 2002).

To address these issues, we investigated crossing effects in a series of four experiments conducted in the same participants. We found a crossing effect in the localization of a single touch, but not when these touches had to be detected rather than localized, which excludes a motor account for crossing effects. Next, we increased perceptual load by adding a second, irrelevant tactile stimulus in the localization task. A larger crossing effect than in the localization of one stimulus emerged. Finally, when TOJ were performed, the largest crossing effect was found, demonstrating an influence of task instructions on the crossing effect. A correlation analysis confirmed that all three crossing effects were significantly. On the one hand, the present results are in agreement with the claim that remapping is automatic (Kitazawa, 2002, Azañón, Camacho, & Soto-Faraco, 2010). On the other hand different degrees of crossing effects across experiments suggests top-down modulations of the same.

We propose a hierarchical probabilistic model of touch localization under coordinate conflict which can account for this contradiction. In this model, the probability to localize a touch to the right (left) hand is determined by its independently weighted anatomical and external coordinates. In contrast to popular accounts of the crossing effect in TOJ (Yamamoto & Kitazawa, 2001, Kitazawa, 2002), remapped coordinates are assumed to be unambiguous. The model was able to accommodate data from our three experiments. Regression analyses showed that individual differences in crossing effects were determined by both frames of reference. Furthermore, comparison of a model with fixed parameters across postures with a model, which assumed different processing in the uncrossed and crossed postures, suggested that the integration of the two reference frames is independent of posture. This result emphasizes that crossing effects reflect coordinate conflict in the crossed positions rather than higher remapping effort due to the unusual posture. Finally, the model accounted for the modulation of the crossing effect by adjusting the weights of the anatomical and external coordinates. This result suggests that top-down influences are exerted on the different reference frames for tactile localization rather than on the remapping process itself.

1. Azañón, E., Camacho, K., & Soto-Faraco, S. (2010). Tactile remapping beyond space. *Eur J Neurosci*, 31(10), 1858–1867.
2. Azañón, E., Longo, M. R., Soto-Faraco, S., & Haggard, P. (2010). The posterior parietal cortex remaps touch into external space. *Curr Biol*, 20(14), 1304–1309.
3. Kitazawa, S. (2002). Where conscious sensation takes place. *Conscious Cogn*, 11(3), 475–477.
4. Röder, B., Rösler, F., & Spence, C. (2004). Early vision impairs tactile perception in the blind. *Curr Biol*, 14(2), 121–124.
5. Shore, D. I., Spry, E., & Spence, C. (2002). Confusing the mind by crossing the hands. *Brain Res Cogn Brain Res*, 14(1), 153–163.
6. Yamamoto, S., & Kitazawa, S. (2001). Reversal of subjective temporal order due to arm crossing. *Nat Neurosci*, 4(7), 759–765.

Disentangling cross-modal top-down predictive control by actively manipulating arbitrarily learned associations

Abhilash Dwarakanath¹, Christoph Kayser²

¹Max-Planck-Institut für Biologische Kybernetik, Tübingen, Germany

²Dept. of Psychology, University of Glasgow, Glasgow, UK

Various studies have characterised the brain as an efficient coding system, thereby describing sensory processing as being optimised to the incoming statistics of natural stimuli. A key framework in this respect is that of predictive coding, which asserts that the brain actively predicts an upcoming sensory stimulus via top-down control mechanisms rather than passively registering it. This top-down control involves the propagation of a prediction to the primary sensory area where the error signal between the prediction and the incoming stimulus is calculated and propagated to higher areas for refinement of the prediction. Accurate predictions hence lead to a decrease in activity in early sensory areas, a presumed signature of predictive coding which several studies used to confirm the theory. However many studies used high level stimuli such as speech, for which subjects have strong and innate priors and which come with potentially confounding contextual variables and changes in attention.

To account for such confounding effects in tests of predictive coding, we designed non-contextual priors consisting of arbitrary associations of random perceptual features. We used visual stimuli consisting of Gabor patches of six orientations (from 0° to 165°) paired with pseudo-natural acoustic soundscapes created by filtering a natural sound in six frequency bands (128 Hz to 8192 Hz, logarithmic steps). For each subject one orientation was randomly associated with one frequency band, and the subject was exposed to short presentations (1.5s) of these pairs for 15min.

Subsequently we tested the impact of this learned predictive association on stimulus recognition in supra-, subliminal and occluded conditions using a 2AFC task. Stimuli were rendered subliminal using each subjects contrast detection threshold and occluded stimuli were masked to 50% by white pixel noise. During the test phase we presented stimuli both as pairs by preserving the previous pairing (control phase) and by pairing sounds with different orientations in order to see whether the acoustic predictor changes the perceived orientation. Responses were analysed by calculating bias and d' for each trial type and a shift in the 50% response bias was taken as evidence for a predictive effect on perceptual decisions.

The important finding is that in the test condition we found a shift of the bias towards the orientation predicted by the sound in subliminal, catch and occluded trials. Our results hence provide evidence for predictive coding and top-down biasing in the context of arbitrary audio-visual associations.

Symposium

S16: Growing up in the brain: how do axons find their way?

- S16-1** What axons tell each other: axon-axon signaling during peripheral nerve and circuit assembly.
Jorge Leon Morales-Quezada
- S16-2** microRNA-9 promotes the switch from early -born to late -born motor neuron populations by regulating Onecut transcription factor expression
Andrea B Huber Brösamle
- S16-3** Molecular control of cortico-cortical axonal navigation.
Victor Tarabykin
- S16-4** Wnt/calcium signaling mediates cortical axon growth and guidance
Katherine Kalil
- S16-5** Connecting left and right brain: the role of Semaphorins in midline axon guidance.
Fanny Mann
- S16-6** ROLE OF SIP1 IN ORCHESTRATING NEOCORTICAL CONNECTIVITY
Swathi Srivatsa, Srinivas Parthasarathy, Anjana Nityanandam, Zoltan Molnar, Victor Tarabykin

What axons tell each other: axon-axon signaling during peripheral nerve and circuit assembly.

Jorge Leon Morales-Quezada^{1,2}

¹Developmental Neurobiology Laboratory, European Neuroscience Institute – Göttingen

Peripheral nerves (PNs) comprise neural pathways facilitating efferent control over movement apparatus and organ function and afferent pathways underlying somatosensation. Developmental or regenerative assembly of PNs entails orderly integration of these pathways within common nerve trajectories, and provides an accessible model for studying organizing principles that accommodate vast arrays of axon types into the white matter tracks of the CNS. Misalignment of axon types can lead to catastrophic intermingling of functionally disparate pathways, underlying conditions including neuropathic pain. Despite the central importance for the parallel establishment of neuromuscular, somatosensory and sympathetic circuitries, the coordinating principles that integrate different axon types into tightly aligned yet functionally segregated PN pathways remain poorly understood. My group investigates dynamic processes driving trans-axon interactions, and their contribution to the developmental and regenerative assembly of PNs and their corresponding circuitries at the anatomical and functional level through targeted gene and cell-lineage manipulation, electrophysiology and live-cell microscopy.

PN assembly has long been thought to involve the establishment of an initial pattern of peripheral trajectories by motor efferent axons (MEs) providing a scaffold for later-extending axon types. We could recently provide a mechanistic basis for some of these ideas by showing that in mouse sensory afferent axons (SAs) supplying the dorsal trunk are directed by molecular labels on pre-extending MEs. Other recent data on mouse limb innervation, however, support a cooperative model according to which mutual interactions between MEs and SAs only to a minimal degree shape PN trajectories. Studies based on surgical manipulations in frog and chick embryos previously arrived at yet different conclusions, proposing that normal establishment of limb SA tracks can be entirely dissociated from ME extension. Consolidating these conflicting lines of evidence remains difficult because differences in animal models, methodologies and positional identities of the PN segments studied currently preclude their direct comparison.

We sought to resolve these issues by systematically investigating the relationships between molecularly identified peripheral axon types in three phylogenetically distinct vertebrate models: zebrafish (*D. rerio*), chick (*G. gallus domesticus*) and mouse (*M. musculus*). Using genetic modeling in all three species we obtained evidence in support of a conserved hierarchy of axon type interactions that invariably governs ontogenetic PN assembly, and which recapitulates the successive phylogenetic emergence of peripheral circuits in vertebrates. These interactions involve a hierarchical and selective set of interactions between MEs, SAs and sympathetic efferent axons (SEs), which further provide a lead for exploring trans-axonal signaling mechanisms underlying developmental segregation of SEs from SA pathways, and the failure of these mechanisms in peripheral neuropathic pain conditions.

microRNA-9 promotes the switch from early-born to late-born motor neuron populations by regulating Onecut transcription factor expression

Andrea B Huber Brösamle¹

¹Institute of Developmental Genetics, Helmholtz Zentrum München – German Research Center for Environmental Health, Ingolstaedter Landstr. 1, 85764 Neuherberg, Germany

Motor neurons in the vertebrate spinal cord are stereotypically organized along the rostro-caudal axis in discrete columns that specifically innervate various peripheral muscle domains. Originating from the same progenitor domain, the generation of spinal motor neurons is orchestrated by a spatially and temporally tightly regulated set of secreted molecules and transcription factors such as retinoic acid and the Lim homeodomain transcription factors *Isl1* and *Lhx1*. However, the molecular interactions between these factors remained unclear. In this study we examined the role of the microRNA 9 (miR-9) in the specification of spinal motor neurons and identified *Onecut1* (OC1) as one of its targets. miR-9 and OC1 are expressed in mutually exclusive patterns in the developing chick spinal cord, with high OC1 expression in early-born motor neurons and high miR-9 expression in late-born motor neurons. miR-9 efficiently represses OC1 translation *in vitro* and *in vivo*. A gain of miR-9 function leads to an increase in late-born neurons, while miR-9 loss-of-function induces additional OC1-positive motor neurons that display a transcriptional profile typical of early-born neurons. These results demonstrate that regulation of OC1 by miR-9 is a crucial step in the specification of spinal motor neurons and support a model in which retinoids secreted from early-born LMCm neurons induce miR-9 expression in prospective LMCI neurons, which through inhibition of OC1 downregulates *Isl1* expression. In conclusion, our study contributes essential factors to the molecular network specifying spinal motor neurons and emphasizes the importance of microRNAs as key players in the generation of neuronal diversity.

Molecular control of cortico-cortical axonal navigation.

Victor Tarabykin¹

¹Charité - Universitätsmedizin Berlin, CCO - Institut für Zell- und Neurobiologie, Berlin, Germany

The neocortex, designated as the seat of our highest cognitive abilities, relies largely on the appropriate connections of cortical neurons with other brain regions, including the neocortex itself. One of the major axonal tracks that interconnect the two cerebral hemispheres is the corpus callosum. Malformations of the corpus callosum in humans occur in over 50 congenital syndromes that are associated with a wide spectrum of deficits. Callosal projection neurons are critical for bilateral transfer and integration of cortical information and have been implicated in autism spectrum disorders. Absence or surgical disruption of corpus callosum in humans is also associated with deficits in abstract reasoning and problem solving.

Recently we identified *Satb2*, *Sip1* and *NeuroD* transcription factors as major players in corpus callosum development. Molecular pathways controlling cortico-cortical axon navigation downstream of these factors will be discussed.

Wnt/calcium signaling mediates cortical axon growth and guidance

Katherine Kalil¹

¹University of Wisconsin-Madison, Department of Neuroscience, 1300 University Ave., 53706 Madison, Wisconsin, USA

Wnts are morphogens that can function as axon guidance cues. In vivo Wnt5a gradients via Ryk receptors repel cortical axons into developing callosal and corticospinal pathways. In cortical cultures, we found that Wnt5a increased axon outgrowth. In turning assays, Wnt5a gradients simultaneously increased axon outgrowth and induced repulsive turning, a mechanism for propelling cortical axons in vivo. Axon outgrowth is mediated by Ryk, whereas axon repulsion requires both Ryk and Frizzled receptors. Both receptors mediate Wnt-evoked fluctuations in intracellular calcium, required for increased axon outgrowth and repulsion by Wnt5a. However, whereas increased axon outgrowth involves calcium release from stores through IP3 receptors as well as calcium influx through TRP channels, axon repulsion is mediated by TRP channels. These results reveal distinct signaling mechanisms underlying Wnt5a-induced axon outgrowth and repulsive guidance. Does calcium signaling play a role in the growth and guidance of cortical axons in vivo? To investigate this question, we used a cortical slice model in which cortical neurons were transfected with a calcium biosensor to image calcium activity in growing corpus callosal axons. Measurements of calcium activity showed that higher frequencies of calcium transients were associated with faster rates of outgrowth. Wnt5a gradients surround the corpus callosum in vivo. Therefore, we asked whether Wnt/calcium signaling mechanisms regulate the growth and guidance of callosal axons. Pharmacological approaches in cortical slices showed that signaling pathways involving calcium release through IP3 receptors and calcium entry through TRP channels regulate post-crossing callosal axon outgrowth and guidance. CaMKII is also an important signaling component in the Wnt/calcium pathway since inhibiting CaMKII reduced axon outgrowth and caused guidance errors in the corpus callosum. Remarkably, knockdown of the Wnt receptor Ryk reduced rates of callosal axon outgrowth and caused guidance errors by attenuating calcium signaling, revealing the importance of Wnt/calcium signaling in vivo. What cytoskeletal mechanisms underlie the growth and guidance effects of Wnt5a? To examine the role of microtubule (MT) reorganization and dynamics we transfected dissociated cortical neurons with EGFP-EB3 to label dynamic MTs. Live cell imaging with TIRF microscopy revealed that Wnt5a increased axon outgrowth by reorientation of dynamic MTs in the direction of axon extension and Wnt5a gradients induced asymmetric redistribution of dynamic MTs toward the far side of the growth cone. Wnt5a gradients also evoked calcium transients that were highest on the far side of the growth cone. To explore a possible relationship between calcium signaling and the reorganization of dynamic MTs we examined the role of tau, a MT associated protein (MAP). Tau is phosphorylated by CaMKII, which is downstream of calcium signaling and is required for Wnt5a induced axon outgrowth and repulsion. Phosphorylation of tau at its Ser262 binding site detaches tau from MTs to increase their dynamics. Using transfection of cortical neurons with tau constructs mutated at Ser262, we found that the Ser262 site is required for the growth and guidance effects of Wnt5a by mediating reorganization of dynamic MTs in cortical growth cones. Taken together, these results link Wnt/calcium signaling and MT reorganization in the regulation of cortical axon growth and guidance by Wnt5a.

Connecting left and right brain: the role of Semaphorins in midline axon guidance.

Fanny Mann¹

¹CNRS, IBDML UMR 7288, Campus de Luminy, 13288 Marseille cedex 09, France

The mammalian brain consists of two hemispheres which communicate with each other through nerve fiber bundles, called commissures. Understanding how commissures develop is an important clinical problem. First, commissural agenesis is a relatively common and often disabling brain malformation. In addition, a higher prevalence of commissural anomalies in the psychiatric population suggests a link between interhemispheric dysconnection and some clinical manifestations associated with these disorders. While the causes of commissural agenesis remain to be elucidated, analysis of residual connectivity in patients revealed aberrant axonal projections at the brain midline. Our team has shown the importance of the guidance signals Semaphorins in the establishment of axon bundles of the brain midline (Chauvet et al., *Neuron*, 2007; Niquille et al., *PLOS Biology*, 2009; Bellon et al., *Neuron*, 2010). The action of Semaphorins occurs via binding to surface receptors on axons, which activate intracellular signaling pathways modulating the axonal cytoskeleton. Our work has shown that VEGFR-2, a receptor involved in the development of the vascular system, is part of a multimeric receptor complex that specifies axon guidance responses to Semaphorins. Recently, membrane trafficking of guidance receptors has emerged as a key regulator of axonal development. However, the fate of internalized receptors, the molecular mechanisms of their intracellular trafficking and the importance of these phenomena for in vivo development remain largely misunderstood. We are currently addressing these questions by studying the role of Synectin, a protein regulating vesicular transport and sorting, in the control of Semaphorin signaling and fasciculation of commissural axons.

ROLE OF SIP1 IN ORCHESTRATING NEOCORTICAL CONNECTIVITY

Swathi Srivatsa¹, Srinivas Parthasarathy^{1,2}, Anjana Nityanandam³, Zoltan Molnar⁴,
Victor Tarabykin¹

¹Institute for Cell and Neurobiology, Charité, Cortical Development Group, Berlin, Germany

²Max Plank Institute for Experimental Medicine, Göttingen, Germany (IMPRS- Neuroscience)

³Dept. of Cell Biology, Dorris Neuroscience. Centre, The Scripps Res. Inst., La Jolla, CA;

⁴Dept. for Physiology, Anat. and Genetics, Univ. of Oxford, Oxford, United Kingdom

The immense cognitive ability that the neocortex confers on higher primates, to a large extent is dependent on the appropriate development of neocortical connections. Cortical connections form a very complex but a very well defined network in the CNS following predefined pathways which become important conduits for the passage of information. The formation of these functional circuits in turn depends upon many regulatory molecules, which act as master orchestrator, helping axons find their right target. Here, we report that Smad-interacting-protein-1 (Sip1), a cortical postmitotic transcriptional repressor is essential for the appropriate establishment of neocortical connectivity.

In the absence of Sip1 many of the white matter tracts within the brain are severely affected. In this study we have shown that Sip1 mutants lack a corpus callosum, forming probst bundles instead and an anterior commissure. Interestingly the hippocampal commissure remains unaffected. While cortico-thalamic connections are largely intact, cortico-subcerebral projections seem to degenerate during early postnatal stages. We have further looked at the role of Sip1 in the organization of midline guidance structures like the glial sling and the midline neuronal population of the corpus callosum, which in turn could be responsible for the inability of callosal fibers to cross the midline in the Sip1 mutant.

Symposium

S17: Heterogeneity of microglia

S17-1 Microglial responder subsets upon TLR challenges
Uwe-Karsten Hanisch

S17-2 Synaptic pruning by microglia: sculpting brain connectivity
Rosa Chiara Paolicelli, Yang Zhan, Giulia Bolasco, Francesca Pagani, Laura Maggi, Maria Scianni, Tiago Ferreira, Eva Guiducci, Laura Dumas, Patrizia Panzanelli, Maurizio Giustetto, Davide Ragozzino, Cornelius T Gross

S17-3 Age-specific heterogeneity in microglial regulation of synaptic maturation and maintenance
Monica Carson

S17-4 Regional heterogeneity of microglia and microglial responses
Knut Biber

S17-5 Microglia/macrophage – glioma interaction
Susanne A. Wolf, Katyayni Vinnakota, Feng Hu, Min-Chi Ku, Helmut Kettenmann

Microglial responder subsets upon TLR challenges

Uwe-Karsten Hanisch¹

¹University of Göttingen, Institute of Neuropathology, Robert-Koch-Straße 40, 37075 Göttingen, Germany

Toll-like receptors (TLRs) enable microglia to sense and to respond to infection and damage. Yet it is unknown whether all cells of an affected population would upregulate the same repertoire of cell surface receptors or synthesize an identical set of soluble messengers—or whether subsets of responding cells would differ by specific contributions to the reactive phenotype. We found that murine microglia reorganize their TLR systems during postnatal development. For TLR4, this process comes with an increased agonist discrimination and a maturation of inducible functions. While induction of MHC I molecules for antigen presentation remains a virtually pan-population response feature synthesis of TNF α becomes restricted to a microglial subset. Responder subsets were identified *ex vivo*, *in situ* and *in vivo*—notably also within circumscribed regions of the adult mouse as well as in the human CNS. Microglial response heterogeneity is thereby not limited to TNF α production or to challenges of TLRs. Production of other proinflammatory factors, induction of MHC II expression or the clearance of myelin in physiological and pathophysiological contexts rely on dissimilar contributions of apparently specialized cells. We conclude that microglia do not comprise a uniform cell type throughout the CNS and that even neighbouring cells could vary by constitutive and recruited capacities. Privileged production of critical mediators, such as TNF α , could enable a ‘master’ subtype of microglia to govern TNF α receptor-expressing cells. Clearance of endogenous material, such as of myelin, could be performed in microglia that do not carry much antigen presentation potential, as to the upregulation of MHC II, in order to sequester incompatible activities. Such an organization in exclusive cellular compartments could thus be a principle of task splitting and hierarchical control as well as a measure to avoid collision of functions. Specialization appears to apply to both house-keeping duties as well as to responses in emergency situations and could underlie the assembly of reactive phenotypes during CNS infection, tissue injury and rebuilding, warranting consideration in experimental manipulation and therapeutic strategies.

Synaptic pruning by microglia: sculpting brain connectivity

Rosa Chiara Paolicelli¹, Yang Zhan², Giulia Bolasco², Francesca Pagani³, Laura Maggi³, Maria Scianni³, Tiago Ferreira², Eva Guiducci², Laura Dumas², Patrizia Panzanelli⁴, Maurizio Giustetto⁴, Davide Ragozzino³, Cornelius T Gross²

¹University of Zurich, Division of Psychiatry Research, August Forel-Strasse 1, 8008 Zurich, Switzerland

²Mouse Biology Unit, European Molecular Biology Laboratory (EMBL), Via Ramarini 32, 00015 Monterotondo, Italy

³Pasteur Institute, Foundation Cenci Bolognetti, and Department of Human Physiology and Pharmacology, Center of Excellence BEMM, University of Rome, La Sapienza, Piazzale Aldo Moro 5, 00185 Roma, Italy

⁴Department of Anatomy, Pharmacology, and Forensic Medicine, University of Turin, 10126 Turin, Italy

Microglia are non-neuronal, phagocytic cells that infiltrate the brain during development and play an important surveillance and scavenging function. An established literature has documented how these immune cells of the brain promptly move toward the site of damage, engulf cellular debris, and rapidly act to resolve injuries in a pathological context. However, less work has been aimed at understanding their role in the uninjured, developing brain and their contribution to synaptic remodelling. Emerging data are now revealing how microglia, by actively engulfing synaptic material during the early postnatal period, play a major role in synaptic pruning and are necessary for a proper refinement of neural circuits. Mice lacking the chemokine receptor *Cx3cr1* show a transient reduction in microglia in the hippocampus during the early postnatal weeks and exhibit an excess of weak excitatory synapses, as a consequence of deficit in synaptic pruning. Interestingly, transient defects in synaptic connectivity are associated with long-term behavioural impairments in social interaction, and increased repetitive behaviour, hallmarks of autism spectrum disorders. These findings provide evidence for a critical role of microglia in long lasting sculpting of brain connectivity, and support the hypothesis that deficits in microglia-mediated synaptic pruning may contribute to some structural and behavioural features of autism.

Age-specific heterogeneity in microglial regulation of synaptic maturation and maintenance

Monica Carson¹

¹University of California Riverside, Division of Biomedical Sciences, School of Medicine, 1274 Webber Hall, 92521 Riverside, USA

Infancy and early childhood are periods characterized by recurring bouts of systemic inflammation in part due to first exposures to pathogens in the home, day care and school. Overt neurologic consequences are not observed in the vast majority of individuals. However, epidemiological studies suggest linkages exist between the onset and/or exacerbation of neurodevelopmental neurologic disorders and various pre-, neo- and post-natal inflammatory events. As yet, little is known about the consequences and developmental regulation of CNS responses to common systemic inflammatory events or their potential for dysregulation by environmental factors. Here, using flow cytometric and immunohistochemical methodologies, we characterize CNS-resident microglia and CNS-infiltrating macrophage activation states in response to systemic immune challenge during critical post-natal periods of brain development and hippocampal synaptogenesis. In brief, we find that that glia and macrophages not only regulate synaptic maturation during normal development but also in response to routine inflammatory insults. Here we link developmental heterogeneity of microglial phenotype with regional regulation of synaptic maturation. For example, using overexpression and knock-out approaches, we specifically find that TREM2 dependent microglial functions modulate the ratio of excitatory to inhibitory synapses in response to bouts of systemic inflammation as well as during normal unmanipulated CNS development. However, TREM2-dependent regulation is restricted to specific developmental windows. Taken together, our data define a developmentally regulated baseline of CNS-intrinsic neuroprotective responses to inflammatory signals that not only modulate synaptic maturation but that that have the potential to be disrupted by environmental, pathogenic or genetic factors.

Regional heterogeneity of microglia and microglial responses

Knut Biber¹

¹University Freiburg, Department of Psychiatry and Psychotherapy, Hauptstr.5, 79104 Freiburg, Germany

The brain is regionally highly organized, meaning that specific functions are assigned to particular brain regions or even to particular neuronal subtypes. This regional high specificity of neurons may also be reflected by the well known different sensitivity of neuronal subtypes towards harmful events. As a most likely consequence brain diseases show considerable specificity, mostly affecting single regions and specific cell types only.

Despite the well-known importance of microglia in brain diseases, research has yet pre-dominantly focused on differences in neurons to understand the vulnerability of certain brain areas in disease. Given the importance of neuronal signals for the control of microglia and the diversity of neurons in various brain regions, we compared acutely isolated microglia from different adult mouse brain regions by flow cytometry, RNA expression analysis and functional tests. The purity of our microglia preparations was higher than 95% based on CD11b high CD45 low staining. Microglia from different regions showed significant, region-specific differences in expression levels of various markers, thus corroborating the concept of distinct microglia phenotypes in the non-inflamed brain.

Regional microglia responses were analysed in organotypic hippocampal slice cultures (OHSC) in which the principal neuronal subtypes (CA1, CA3 and DG neurons) show considerable different sensitivities towards NMDA-induced excitotoxicity. It is presented here that microglia responses very well have region specific influences on the survival of CA versus DG neurons in the OHSC. Whether or not these differences can be attributed to different microglia subtypes, or whether the particular neuronal populations respond differently to microglia remains to be established.

Microglia/macrophage – glioma interaction

Susanne A. Wolf¹, Katyayni Vinnakota¹, Feng Hu¹, Min-Chi Ku¹, Helmut Kettenmann¹

¹Max-Dellbrück-Center, Cellular Neuroscience, Robert-Rössle-Str. 10, 13125 Berlin, Germany

High-grade gliomas are the most common primary brain tumors. One process that closely correlates with malignancy and poor clinical prognosis is the accumulation of microglia/macrophages in and around the tumor. It is important to note that glioma tissue samples can contain up to 30% microglia/macrophages. Our group has previously established that glioma cells convert microglia/brain macrophages into a distinct phenotype with pro-tumorigenic properties and this signaling was mediated by soluble factor(s). When screening the Rembrandt (Repository for Molecular Brain Neoplasia Data) database, we found that Toll-like receptor 2 (TLR2) gene expression was highly up-regulated in human glioma tissue and the upregulation correlated with shorter survival. In the brain TLR2 is predominantly expressed by glia cells. In vivo implantation of mouse GL261 glioma cells into TLR2 knock-out mice resulted in significantly smaller tumors, and enhanced survival rates as compared to wild-type control mice indicating the involvement of microglia rather than glioma cells in TLR2-mediated signaling. Indeed, TLR2 controls up-regulation of membrane -type 1 matrix metalloprotease (MT1-MMP) in microglia. This was further confirmed by studying glioma expansion in organotypic brain slices which was dependent both on the involvement of TLR2 and the presence of microglia. The up-regulation of MT1-MMP expression by glioma conditioned medium was mimicked by TLR2-specific ligands in microglia from wild-type mice but not in microglia from TLR2-deficient mice. A less pronounced, yet significant effect of glioma conditioned medium-induced MT1-MMP expression was also observed in microglia from TLR1 and TLR6-deficient mice which are known as heterodimeric partners of TLR2. In Toll-like receptor 7 and 9 knock-out mice, glioma conditioned medium-induced MT1-MMP expression in microglia was not affected. Our results thus show that TLR2/1 and TLR2/6 are an essential part of the signaling cascade by which glioma cells convert microglia into a pro-tumorigenic phenotype.

To find factors which mediate the attraction of microglia to gliomas, we established a cell encapsulation model. Mouse GL261 and human glioma cells were seeded into hollow fibers (HF) that allow the passage of soluble molecules but not cells. We identified GDNF as an important factor for microglial attraction towards the tumor. Reduced GDNF production by siRNA in GL261 mouse glioma cells diminished attraction of microglia while over-expression of GDNF in fibroblasts promoted microglia attraction in our HF assay. In vitro migration assays also showed that GDNF is a strong chemoattractant for microglia. Finally, we could show that GDNF knockdown by shRNA in mouse glioma cells reduced tumor expansion and improved survival in an experimental mouse tumor model. These data indicate that glioma associated microglia/macrophages are a potential target for novel therapeutic strategies.

Symposium

S18: Optodynamics of channels and receptors

S18-1 Optochemical Genetics
Dirk Trauner

S18-2 Parallel recording of ligand binding and ion channel activation using confocal patch-clamp fluorometry
Jana Kusch, Vasilica Nache, Susanne Thon, Eckhard Schulz, Christoph Biskup, Thomas Zimmer, Klaus Benndorf

S18-3 Structural transitions during voltage-dependent activation of sodium channels
Baron Chanda, Marcel Goldschen-Ohm, Kevin Oelstrom

S18-4 STATE-DEPENDENT FRET REPORTS LARGE GATING -RING MOTIONS IN WHOLE BK CHANNELS AT THE MEMBRANE
Teresa Giraldez

S18-5 Nano-organization of the AMPA receptors inside the synapse and physiological role
eric hosy

S18-6 PHOTOINACTIVATION OF GLUTAMATE RECEPTORS USING A GENETICALLY ENCODED UNNATURAL AMINO ACID
Viktoria Klippenstein, Andrew Plested

Optochemical Genetics

Dirk Trauner¹

¹Ludwig-Maximilians-Universität München (University of Munich), Department of Chemistry, Butenandtstr. 5-9, 81377 Munich, Germany

Transmembrane receptors allow a cell to communicate with its environment in response to a variety of input signals. These can be changes in the concentration of ligands (e.g. hormones or neurotransmitters), temperature, pressure (e.g. via acoustic waves or touch), transmembrane potential, or light intensity. Many important receptors have now been characterized in atomic detail and our understanding of their functional properties has markedly increased in recent years. As a consequence, these sophisticated molecular machines can be reprogrammed to respond to unnatural input signals. Arguably, the most useful of these signals is light. I will show how ligand-gated ion channels, G-protein coupled receptors, as well as voltage-gated ion channels, can be manipulated with synthetic photoswitches to become light-sensitive. The resulting hybrid photoreceptors can be used to optically control neurons with very high precision. They have been used to dissect neural networks and might find applications in the restoration of vision and the control of other sensations (such as pain). This combination of synthetic photoswitches and receptor proteins augments the field of Optogenetics and adds a new functional dimension to Chemical Genetics. As such, we propose to call it "Optochemical Genetics".

Parallel recording of ligand binding and ion channel activation using confocal patch-clamp fluorometry

Jana Kusch¹, Vasilica Nache¹, Susanne Thon¹, Eckhard Schulz², Christoph Biskup³,
Thomas Zimmer¹, Klaus Benndorf¹

¹Universitätsklinikum Jena, Institut für Physiologie II, Kollegiengasse 9, 07743 Jena, Germany

²Fachhochschule Schmalkalden, Fakultät Elektrotechnik, Blechhammer, 98574 Schmalkalden, Germany

³Universitätsklinikum Jena, AG Biomolekulare Photonik, Nonnenplan 4, 07743 Jena, Germany

Ligand-gated ion channels are essential components of electrical signaling in neurons, playing an important role, for example, in mediating synaptic and receptor potentials. Ligand binding causes channel gating, conformational changes in the channel protein leading to the opening of a pore, and thus ion fluxes into or out of the cell. Ligand binding and activation gating interdepend on each other in a reciprocal fashion: ligand binding promotes activation gating and activation gating promotes ligand binding (2).

To shed light on this intrinsic relation in a ligand-gated ion channel, parallel monitoring of ligand binding and channel gating is required. Therefore we developed confocal patch-clamp fluorometry (confocal PCF), combining electrophysiological patch-clamp techniques and confocal fluorescence microscopy (1). Using confocal PCF the interdependence of ligand binding and activation gating can be directly explored. We applied this method successfully to CNG (cyclic-nucleotide gated) channels and HCN (hyperpolarization-activated and cyclic-nucleotide modulated) pacemaker channels using the fluorescently labeled derivatives fcGMP (8-DY547-AET-cGMP) (1) and fcAMP (8-DY547-AET-cGMP) (2), respectively.

We measured mean fluorescence intensities of the channel-bound ligand and ion currents in inside-out macropatches of *Xenopus laevis* oocytes under steady-state and non-steady state conditions. Fast concentration jumps applied by a piezo-driven double-barreled application system allowed us to monitor time courses of ligand binding channel activation as well as ligand unbinding and deactivation. By means of a global fit strategy taking into account multiple simultaneously measured fluorescence and current data, we proposed Markovian state models for both homotetrameric CNGA2 and HCN2 channels describing their ligand-dependent activation gating.

So far, employing confocal PCF in combination with molecularbiological and mathematical methods led us to new insights into the gating of CNG and HCN pacemaker channels. Provided that a suitable fluorescently labeled ligand exists, parallel studying of ligand binding and channel gating is promising to understand the ligand-induced gating of other ion channels as well.

1. Biskup et al. (2007) Nature 446: 440-3
2. Kusch et al. (2010) Neuron 67: 75-85

Structural transitions during voltage-dependent activation of sodium channels

Baron Chanda¹, Marcel Goldschen-Ohm¹, Kevin Oelstrom¹

¹University of Wisconsin-Madison, Neuroscience, 1300 University Avenue, 53706 Madison, USA

Voltage-gated sodium channels are found in a variety of excitable cells and are crucial for propagation of electrical impulses. They are optimized for rapid initiation and termination of an action potential both in function and form. Single point mutations with seemingly minor biophysical effects can result in serious disease conditions such as epileptic seizures and cardiac arrhythmias. To understand the pathophysiology of these conditions, it is necessary to address the fundamental questions regarding the nature of structural transitions that underlie voltage-dependent response of sodium channels. To study the activation gating process, we have focused on an inactivation-deficient sodium channel mutant. Rapid inactivation is critical for sodium channel function but it complicates biophysical study of the gating process because it masks the channel opening events. In this presentation, I will discuss our recent studies using a combination of voltage-clamp fluorimetry, single-channel analysis and MTS accessibility studies to characterize the intermediates in the activation pathways. Our single channel and fluorescence measurements reveal that pore opening in sodium channels, contrary to gating models of potassium channels, involves multiple transitions and are driven by asynchronous movements of voltage-sensors. However, MTSET accessibility studies reveal that the activation gate is at the C-terminal end of the S6 segments, similar to Shaker potassium channels. Together, these findings shed new light on the mechanisms of activation in asymmetric voltage-dependent ion channels.

STATE-DEPENDENT FRET REPORTS LARGE GATING-RING MOTIONS IN WHOLE BK CHANNELS AT THE MEMBRANE

Teresa Giraldez^{1,2}

¹University Hospital NS Candelaria Research Unit, 38010 Sta Cruz de Tenerife, Spain

²Institute of Biomedical Technologies, University of La Laguna, 38071 La Laguna, Spain

In many neuron types, large conductance voltage- and calcium-dependent potassium channels (BK, hsl α or KCa1.1) provide a mechanism to couple Ca²⁺ signaling to membrane potential. Inherited defects in BK channels function lead to seizure and epilepsy, indicating that this coupling mechanism is crucial to regulate neuron excitability in the healthy brain. In fact, the interaction between Ca²⁺ influx and BK activation is involved in numerous neuronal processes such as repolarization and hyperpolarization following the action potential (AP), dendritic Ca²⁺ spikes, and neurotransmitter release. A key feature to BK physiological role is that the channel's open probability is synergistically activated by transmembrane voltage and intracellular calcium. The voltage sensor resides within the transmembrane region of the channel, while Ca²⁺ binding is sensed by a large C-terminal intracellular region, where eight Regulator of Conductance for K⁺ (RCK) domains form a "gating ring". Calcium binding to this region reduces the energy required to open the channel, but the exact mechanism underlying this process is still uncertain. Structural studies and a biochemical study using isolated gating rings suggest that Ca²⁺ binding expands the gating ring. The large movement of the gating ring would physically pull and open the gate located at the pore domain. In the present study we investigate the calcium and voltage-dependence of conformational changes in the intact human BK channel by patch-clamp recordings and simultaneous measurements of fluorescence energy transfer between CFP and YFP variants of the green fluorescent protein, inserted into three sites in the BK gating ring. Depending of the site studied, different movements are detected that differ in their Ca- and V-dependence. Here we show that Ca²⁺ binding produces large structural changes that are not obligatorily coupled to the opening of the pore.

Nano-organization of the AMPA receptors inside the synapse and physiological role

eric hosy¹

¹CNRS, IINS, 147 rue leo saignat, 33000 Bordeaux, France

The majority of synapses in the central nervous system uses glutamate as a neurotransmitter, and the strength of synaptic transmission is proportional to the number of glutamate receptors (AMPA type) present under the synaptic glutamate release site. Many studies have reported modification of AMPA receptor quantity, organization or composition in response to various physiological stimuli which underlie synaptic maturation and plasticity, memory, disease, etc. However, available optical tools have not led to a precise description of the basic organization of receptors due to the limited pointing accuracy of the optical microscopy. The emergence of super-resolution techniques has broken this limitation barrier, allowing us to understand the organization of the AMPA receptors, and the variation of mobility as a function of its localization inside the synapse.

Here we used 3 different super-resolution techniques (STED, PALM and U-PAINT) to study extensively the organisation and the mobility of AMPAR inside the synapse and we discovered that AMPA receptor are not randomly distributed inside the synapse or even the PSD, but structured in nanodomains of about 80nm. Such distribution allows maintaining a high fidelity of the synaptic response. In parallel, perturbation of one of the main scaffold protein of the PSD, PSD95, affect in the same range the dynamic organization of AMPAR and the synaptic currents.

PHOTOINACTIVATION OF GLUTAMATE RECEPTORS USING A GENETICALLY ENCODED UNNATURAL AMINO ACID

Viktoria Klippenstein¹, Andrew Plested¹

¹Leibniz-Institut Für Molekulare Pharmakologie & Neurocore Initiative, Charité, Molecular Neuroscience and Biophysics, TRH, Robert-Rössle-Str. 10, 13125 Berlin, Germany

Glutamate receptors (GluRs) are ligand-gated ion channels that mediate fast excitatory synaptic transmission in the central nervous system. They play a central role in synaptic plasticity and thus are involved in the basic mechanisms underlying learning and memory.

We have used unnatural amino acid mutagenesis to study conformational changes within the ligand-binding domain (LBD) during and after activation of the receptor. This method has previously been shown to be convenient for neuronal studies (Wang et al, 2007 Nat Neuro). It offers the advantages of high specificity, arbitrary environmental sensitivity of incorporation, and a nearly unlimited variety of unnatural side chains.

We introduced the genetically-encoded photo-cross-linker p-Benzoyl-Phenylalanine (Bpa) to GluRs expressed in mammalian cell lines with a view to suppress an amber (TAG) codon introduced to the lower (D2) lobes of the LBD (S729, G725). These sites have been previously shown to form intermolecular disulfide cross-links that inhibit the receptor (Armstrong et al, 2006 Cell; Plested and Mayer, 2009 J. Neurosci). The insertion of Bpa was carried out by an exogenous pair of a tRNA and a tRNA-synthetase (Ye et al, 2008 J Biol Chem). Sensitive electrophysiological rapid perfusion measurements demonstrated that Bpa-rescued GluRs are fully functional and can be trapped in inactive conformational states upon UV irradiation, consistent with the previously described findings. GluR trapping was indicated by near-complete peak current reduction in less than five seconds cumulative exposure to UV at 365 nm from a mercury lamp. The cross-linking rate depended on UV intensity and exposure time. Wild type channels were unaffected by similar UV exposures.

Our results demonstrate that genetically-encoded unnatural amino acids such as Bpa provide a convenient strategy to control activity of ligand-gated ion channels in mammalian cells.

Symposium

S19: GABAergic mechanisms in neurobiology of disease

- S19-1** GABA(A)receptors in the pathophysiology of epilepsy
Jean-Marc Fritschy
- S19-2** Cytosolic carbonic anhydrases in the control of GABAergic excitation and febrile seizures
Eva Maria Ruusuvuori, Antje K Huebner, Ilya Kirilkin, Alexey Yukin, Peter Blaesse, Mohamed Helmy, Hyo Jung Kang, Malek El Muayed, J Christopher Hennings, Juha Voipio, Nenad Sestan, Christian A Hübner, Kai Kaila
- S19-3** Activity-dependent cleavage of KCC2 mediated by calpain suggests a general mechanism for erosion of inhibition
Martin Puskarjov, Faraz Ahmad, Peter Blaesse, Kai Kaila
- S19-4** RNA processing in temporal lobe epilepsy
Jochen Christian Meier
- S19-5** Optogenetic control of hippocampal oscillations by stimulation of medial septal PV⁺ interneurons
Falko Fuhrmann, Daniel Justus, Hiroshi Kaneko, Susanne Schoch, Stefan Remy
- S19-6** GABAergic control of depressive and antidepressive brain states
Bernhard Lüscher, Zhen Ren, Qiuying Shen, Thomas Fuichs, Chicheng Sun, Gong Chen
- S19-7** Gephyrin in neurodegenerative disease
Guenter Schwarz

GABA(A)receptors in the pathophysiology of epilepsy

Jean-Marc Fritschy¹

University of Zurich, Institute of Pharmacology and Toxicology, Winterthurerstrasse 190, 8057 Zurich, Switzerland

GABAA receptors are ligand-gated channels activated by GABA, thereby mediating fast phasic synaptic as well as tonic extrasynaptic inhibitory neurotransmission. Functional and pharmacological diversity emerges through assembly of various GABAA receptor subtypes from a large family of subunits. In addition, GABAA receptor function and localization are fine-tuned by post-translational modifications and by differential interactions with synaptic scaffolding proteins and signaling molecules. As GABAergic transmission plays a key role in controlling neuronal excitability and synchronization, alterations affecting either pre- or postsynaptic GABAergic function, including GABAA receptors themselves, can result in epilepsy. Accordingly, a number of mutations have been described in genes encoding GABAA receptor subunits, causing various forms of idiopathic epilepsies. Conversely, signaling mechanisms activated by seizures can alter GABAA receptor subunit gene expression, trafficking, and posttranslational modifications. Likewise, alterations in neuronal circuits affecting GABAergic transmission can either trigger epileptogenesis and seizures, or be caused by them, as evidenced in acquired epilepsies, e.g. after perturbation of brain development or after head trauma. In this talk, I will present specific examples illustrating these various features and outline contemporary research avenues designed to better understand the role of GABAA receptors in epilepsy and to identify novel possible therapeutic avenues.

Cytosolic carbonic anhydrases in the control of GABAergic excitation and febrile seizures

Eva Maria Ruusuvuori¹, Antje K Huebner², Ilya Kirilkin¹, Alexey Yukin¹, Peter Blaesse¹, Mohamed Helmy¹, Hyo Jung Kang³, Malek El Muayed², J Christopher Hennings², Juha Voipio¹, Nenad Sestan³, Christian A Hübner², Kai Kaila¹

¹University of Helsinki, Physiology and Neuroscience, POB 65, 00014 University of Helsinki, Finland

²Institute of Human Genetics, University Hospital Jena, Friedrich-Schiller-University Jena, Kollegiengasse 10, 07743 Jena, Germany

³Department of Neurobiology and Kavli Institute for Neuroscience, Yale University School of Medicine, New Haven, Connecticut 06510, USA

Intense GABA_A receptor (GABA_AR) activation causes excitation of neurons and neuronal networks. This is because GABA_ARs are permeable to both Cl⁻ and HCO₃⁻, and the latter ion acts as a carrier of depolarizing GABAergic current. The potent excitatory action of HCO₃⁻ during persistent GABA_AR activation is based on the continuous replenishment of HCO₃⁻ within neurons by cytosolic carbonic anhydrase (CA) activity. These findings put intraneuronal CA in a key position in GABAergic excitation with a possible role in the generation of seizures *in vivo*. However, it has remained unclear which CA isoforms are present in neurons and what is the specific role of distinct cytosolic isoforms in the modulation of GABAergic signalling.

Using a novel CA VII knockout mouse, a CA II knockout and a novel CA II/VII double knockout, we show that these two catalytically highly active cytosolic isoforms are solely responsible for CA-dependent modulation of intraneuronal pH in the somata and dendrites of mouse CA1 hippocampal neurons. The neuron-specific CA VII expression commences at postnatal day 10 (P10), while the ubiquitous isoform II is detected in neurons after P18. Both isoforms are equally effective in promoting HCO₃⁻-driven GABAergic excitation during intense GABA_AR activation.

We present two lines of evidence which suggest a specific role for CA VII-dependent GABAergic excitation in promoting experimental febrile seizures (eFS). Using epidural EEG recordings we show that hyperthermia reliably evokes robust eFS with cortical electrographic seizure activity in P13-14 wild type mice but fails to do so in the CA VII knockout. eFS were fully prevented when hyperthermia was induced in the continuous presence of 5 % CO₂. In further agreement of the view that eFS are triggered by respiratory alkalosis and boosted by GABAergic excitation, a low dose of diazepam facilitated eFS, whereas they were blocked at concentrations that suppressed breathing. In the human cortex and hippocampus, CA VII mRNA was found to be present already at the late fetal stage, well before 6 months of age when FS are typically first observed. Thus, CA VII is a key molecule in age-dependent neuronal regulation of pH with consequent effects on seizure generation.

Activity-dependent cleavage of KCC2 mediated by calpain suggests a general mechanism for erosion of inhibition

Martin Puskarjov¹, Faraz Ahmad¹, Peter Blaesse¹, Kai Kaila¹

¹University of Helsinki, Department of Biosciences, Viikinkaari 1 P.O. box 65, 00014 Helsinki, Finland

The K-Cl cotransporter KCC2 plays a crucial role in neuronal chloride regulation. In mature central neurons, KCC2 is responsible for the low intracellular Cl⁻ concentration which forms the basis for hyperpolarizing GABA_A receptor-mediated responses. Fast changes in KCC2 function and expression have been observed under various physiological and pathophysiological conditions. Here, we show that the application of protein synthesis inhibitors cycloheximide and emetine to acute rat hippocampal slices has no effect on total KCC2 protein level and cotransport function. Furthermore, blocking constitutive lysosomal degradation with leupeptin did not induce significant changes in KCC2 protein levels. These findings indicate a low basal turnover rate of the total KCC2 protein pool. In the presence of the glutamate receptor agonist NMDA, total KCC2 protein decreased to about 30% within 4 hours. This effect was completely blocked by calpeptin and MDL-28170, inhibitors of the calcium-activated protease calpain. To assess whether calpain directly cleaves KCC2, we applied recombinant calpain to rat brain homogenate, which resulted in rapid loss of KCC2. In order to study the effects of activity-dependent calpain activation on KCC2-mediated Cl⁻ extrusion, interictal-like activity was induced by incubation of hippocampal slices in an Mg²⁺-free solution. This led to a fast reduction in KCC2-mediated Cl⁻ transport efficacy in CA1 pyramidal neurons, paralleled by a decrease in both total and plasmalemmal KCC2 protein. Both effects were blocked by MDL-28170. Taken together, these findings show that calpain activation leads to cleavage of KCC2, thereby modulating GABAergic signaling. This work adds a major player in GABAergic signaling, KCC2, to the growing list of calpain substrates involved in GABAergic signaling. A corollary of this suggests that calpain-activation may act as a common executor, which synchronizes the activity-dependent down-regulation of key GABAergic proteins, and thereby could mediate erosion of inhibition as seen in chronically epileptic networks.

RNA processing in temporal lobe epilepsy

Jochen Christian Meier¹

¹Max-Delbrück-Center for Molecular Medicine, Neuroscience, Robert-Rössle-Strasse 10, 13092 Berlin, Germany

Epilepsy is one of the commonest neurological disorders, and the number of patients with epilepsy is increasing steadily. In fact, epilepsy has remained drug-resistant in 30% of the cases for the past 70 years, and present antiepileptic drugs suppress seizures but there are no therapeutic options against epileptogenesis, a sign of our ignorance of underlying mechanisms. Most epilepsy syndromes have no discernable genetic component, indicating that epileptogenesis must involve disease-promoting mechanisms of neuronal plasticity. At the same time, adaptive responses of neuronal networks can operate to suppress seizure generation and the patho-physiological consequences of neuronal hyperexcitability, such as sclerotic neuronal death and circuit miswiring. Thus, the need for explorative studies addressing the variability of gene products and their impact on cell physiology is evident. In this context, we are investigating variability of selected gene products and their relation to patho-physiology of epilepsy. We discovered that RNA editing of glycine receptor (GlyR) coding mRNA is increased in the hippocampus of patients with temporal lobe epilepsy (TLE). RNA editing generates gain-of-function GlyR with drastically increased apparent affinity for glycine. Furthermore, these receptors don't even need an agonist for channel opening, i.e. they can spontaneously open and increase chloride permeability of the plasma membrane. For in vivo analysis of the functional impact of these receptors, we generated a knock-in mouse that expresses an epitope-tagged version of RNA-edited GlyR $\alpha 3L$, which is the preponderantly expressed long RNA splice variant of the $\alpha 3$ subunit. Data obtained from ultrastructural, cell biological, biochemical and electrophysiological experiments will be presented, revealing GlyR $\alpha 3L$ -interacting vesicular trafficking proteins and expression of these receptors at specific subcellular locations in the hippocampus. Furthermore, I will show data on variability of RNA splicing of gephyrin coding gene transcripts in hippocampi of TLE patients and discuss how this information can be used for invention of novel molecular tools for a neuronal activity-dependent therapeutic strategy that hopefully tackles the disease at the root.

Optogenetic control of hippocampal oscillations by stimulation of medial septal PV⁺ interneurons

Falko Fuhrmann¹, Daniel Justus¹, Hiroshi Kaneko¹, Susanne Schoch³, Stefan Remy^{1,2}

¹Deutsches Zentrum für Neurodegenerative Erkrankungen, Neuronal Substrates of Cognitive Dysfunction, Ludwig-Erhard-Allee 2, 53175 Bonn, Germany

²Klinik für Epileptologie, Universitätsklinikum Bonn

³Institut für Neuropathologie, Universitätsklinikum Bonn

The medial septal nucleus and the diagonal band of Broca (MSDB) play a crucial role in the generation of hippocampal theta rhythm. It has been shown that PV⁺ interneurons rhythmically discharge at theta frequency in vitro and in vivo. These interneurons in the MSDB target interneurons in the hippocampal formation and lead the hippocampal network by providing rhythmic disinhibition. Aberrant hippocampal theta and gamma oscillations are observed both in patients and mouse models of Alzheimer's disease (AD). We expressed ChR2-EYFP (H134R) selectively in PV⁺ interneurons of the MSDB by using stereotactic rAAV injections in PV-Cre mice. Cellular responses of hippocampal pyramidal neurons and interneurons were identified in -vivo by two-photon calcium imaging using GECIs and selective Cre-mediated expression of tdTomato. Local field potential electrodes were placed in close proximity to the imaging field of view. 1) Using patch-clamp in the MSDB single ChR2 positive PV⁺ interneurons could reliably be driven by optic stimulation with a fiber-coupled 470nm diode laser. 2) PV⁺/EYFP positive axons were reliably observed in the CA1 subfield with predominant labeling in str. oriens and pyramidale 3) Stimulation of the MSDB at frequencies in the theta and gamma range, induced phase-coupled rhythmic oscillations in CA1 which recruited pyramidal neurons and interneurons 4) We could reliably control hippocampal oscillations in behaving animals, which is a prerequisite for a successful rhythm restoration in mouse models of AD.

GABAergic control of depressive and antidepressive brain states

Bernhard Lüscher^{1,2,3}, Zhen Ren¹, Qiuying Shen¹, Thomas Fuichs¹, Chicheng Sun¹,
Gong Chen¹

Penn State University , Depts. of Biology¹, Biochemistry & Molecular Biology², and Psychiatry³ , 201 Life Sciences Building,
University Park, Pennsylvania 16802 , USA

Vulnerability for anxiety and depressive disorders is increasingly recognized to involve deficits in GABAergic neurotransmission. In particular, major depression is associated with lower brain concentrations of GABA, reduced function or loss of select subtypes of GABAergic interneurons and altered subunit composition and reduced expression of ionotropic GABA receptors (GABA-ARs). Mice that were rendered heterozygous for the gamma2 subunit gene (*gabrg2*) of GABA-ARs have been shown to exhibit behavioral, cognitive, neuroendocrine and pharmacological characteristics indicative of an animal model of partially drug resistant melancholic anxious depression. They indicate that deficits in GABAergic transmission evident in patients are indeed causative for major depressive disorders. Encouraged by this model, we have used conditional knock-out and pharmacological manipulations of gamma2 subunit -containing GABA-ARs, as well as biochemical, pharmacological and electrophysiological characterization of gamma2 subunit-deficient cultures and mice to further elucidate the molecular and cellular pathways mediating GABAergic deficit-induced depressive states. I will summarize experiments relying on tamoxifen inducible deletion of the gamma2 subunit gene and pharmacological potentiation of GABA-ARs with diazepam that revealed separate critical periods underlying the developmental vulnerability for adult anxiety and depression-related behavior in the Elevated Plus Maze and Forced Swim Test, respectively. Second, I will present biochemical and functional evidence that GABA-AR deficit-induced depressive states involve homeostatic adaptations in glutamatergic transmission. Third, I will summarize our progress in identifying GABAergic neural circuits controlling antidepressant-like brain states in mice.

Gephyrin in neurodegenerative disease

Guenter Schwarz¹

¹University of Cologne, Department of Chemistry, Institute of Biochemistry, Zulpicher Str. 47, 50674 Koeln, Germany

Anchoring and clustering of neuro-receptors is vital for proper signal transmission in the central nervous system. The scaffolding protein gephyrin plays a critical role in organizing postsynaptic structures at glycinergic and a subset of GABAergic (gamma-aminobutyric acid) synapses. In addition, gephyrin catalyzes the biosynthesis of the molybdenum cofactor in peripheral tissue such as liver and kidney. Functional diversity of gephyrin is believed to rely on alternative splicing, which produces at least 10 different variants. A loss of gephyrin results in severe neurodegeneration due to a metabolic defect resulting in the accumulation of excitotoxic metabolites as well as impaired synaptic inhibition. Recently we identified different forms of gephyrin deficiencies leading either to severe childhood death due to loss of all gephyrin functions or the expression of dominant negative variants that affect oligomerization and clustering of gephyrin in the brain. Finally, novel mechanisms of post-translational control of gephyrin-dependent clustering of GABA type A receptors will be presented, each of which contributing to synaptic strength and plasticity at inhibitory sites.

Symposium

S20: Functional specializations of neuroglia as critical determinants of brain activity

- S20-1** Spatiotemporal organization of astrocytic calcium activity
Yuji Ikegaya
- S20-2** ASTROCYTES MODULATE INFORMATION PROCESSING IN VISUAL CORTEX
Gertrudis Perea, Mriganka Sur
- S20-3** Regional and dynamic misexpression of myelin-related and astrocyte-specific transcripts in SHARP1/2 mouse mutants
Moritz J Rossner
- S20-4** Heterogeneity of glial glutamate uptake
Christine Rosemarie Rose
- S20-5** Role of protein translation for astroglial heterogeneity in hippocampal and cortical astrocytes
Daniela Christiane Dieterich
- S20-6** Altered synaptic plasticity and rhythmic oscillations in the hippocampus following vascular injury and blood-brain barrier dysfunction
Kristina Lippmann, Lyn Kaminstky, Svetlana Lublinsky, Julia Nichtweiß, Alon Friedman, Uwe Heinemann
- S20-7** Molecular Mechanisms of Astrocyte Vesicle Release at Synaptic Interfaces
Anne Christine Wolfes, Camin Dean

Spatiotemporal organization of astrocytic calcium activity

Yuji Ikegaya¹

¹The University of Tokyo, Grad School of Pharmaceutical Sciences, 7-3-1 Hongo, 113-0033 Bunkyo-ku, Japan

Astrocytes exhibit various patterns of intracellular calcium elevations, which are often involved in gliotransmission. Although local synchronization and wave-like propagation of astrocytic calcium activities are often reported, the temporal activity patterns of individual cells are poorly characterized at a longer time scale. Here, I utilized large-scale calcium imaging technique to simultaneously visualize and analyze the activity patterns of hundreds of astrocytes in CA1 stratum radiatum of acute hippocampal slices prepared from juvenile mice. I found that among the observed astrocytes, $24.9 \pm 17.1\%$ cells (mean \pm SD) showed unique oscillation patterns, which I named "intermittent oscillations". These cells repeatedly showed clustered oscillation events at an interval of 859 ± 661 s, with only few sporadic activities between the events. Single events persisted for 107.5 ± 56.4 s and involved 3.9 ± 1.6 cycles. Neither the frequency of the events nor the number of intermittently oscillating cells was affected by TTX or AP5, an NMDA receptor antagonist, implicating that the intermittent oscillations are independent of neuronal activity. In contrast, MCPG (a group I and II metabotropic glutamate receptor antagonist) reduced these parameters, while not affecting the overall excitability of astrocytes. Further properties, pharmacological profiles, and spatial allocations of these cells are now under investigation.

ASTROCYTES MODULATE INFORMATION PROCESSING IN VISUAL CORTEX

Gertrudis Perea¹, Mriganka Sur¹

¹Picower Institute for Learning and Memory, Massachusetts Institute of Technology, 46 Vassar St, 02139 Cambridge, USA

Astrocytes are the major glial cell type in the nervous system. They are known to have important roles in brain homeostasis, such as buffering potassium ions and releasing molecules necessary for energy metabolism. Astrocytes have recently been considered to play active roles in synaptic transmission and plasticity in different brain areas. However, the impact of astrocyte activity on cortical networks and on information processing of external stimuli is unresolved. Our results demonstrate that astrocytes are actively involved in information transfer within cortical networks, and they do so by influencing the strength of synaptic connections between cortical neurons.

We used optogenetic techniques to selectively manipulate astrocyte activity in layers 2/3 of primary visual cortex in mice. Astrocytes were selectively targeted with light-sensitive channelrhodopsin-2 (ChR2) to evoke calcium responses in them. We simultaneously recorded the activity of neighboring neurons in these cortical layers – in slices of visual cortex *in vitro* to examine synaptic influences of astrocytes on neurons, and in the intact visual cortex *in vivo* while presenting visual stimuli to the animals to examine the influence of astrocyte activation on tuned visual responses of neurons.

We observed that astrocyte stimulation evoked an increase of both excitatory and inhibitory postsynaptic currents in cortical slices. These effects were mediated by glutamate released from astrocytes and subsequent activation of metabotropic glutamate receptors on neurons. Single neuron recordings *in vivo* demonstrated that astrocyte activity influenced the responses of cortical neurons to specific visual stimuli, and affected excitatory and inhibitory neurons in different ways.

These results show that astrocytes regulate excitatory and inhibitory synaptic transmission in the visual cortex, which in turn drives changes in the excitation/inhibition balance in cortical networks and hence alters response features of visual cortex neurons. Thus, astrocytes are directly involved in the representation and processing of information in the cerebral cortex.

Regional and dynamic misexpression of myelin-related and astrocyte-specific transcripts in SHARP1/2 mouse mutants

Moritz J Rossner¹

¹Max-Planck-Institute of experimental Medicine, Research Group Gene Expression, Hermann-Rein-Str. 3, 37075 Göttingen, Germany

The basic Helix Loop Helix (bHLH) transcription factors SHARP1 and -2 (also known as DEC2/1) are partially redundant modulators of the mammalian clock and SHARP1 has been identified as a regulator of sleep homeostasis in humans and mice. Moreover, Sharp1 and -2 double null mutant mice (S1/2^{-/-}) perform better in learning paradigms that depend on cortical structures and which depend most likely on certain aspects of sleep. Therefore, we analyzed the sleep architecture and sleep-wake associated cortical gene expression in S1/2^{-/-} and wild-type (wt) mice. Somewhat surprisingly, we detected not only neuronal plasticity genes but also different glial transcripts to be deregulated in wt and mutant mice. Among these were several myelin-related as well as astrocyte-specific gene products. The daytime and region dependent de-regulation of selected myelin genes was validated combining laser-microdissection and quantitative RT-PCR. By analyzing synchronized mixed glial cultures from wt and S1/2^{-/-}, we show that the dynamic and genotype dependent regulation of myelin and astrocyte genes is cell-autonomous and independent of a neuronal pacemaker. Moreover, correlating with the cortex-dependent cognitive enhancement, alterations of astrocyte-specific gene expression is restricted to cortical structures and not seen in the hippocampus of S1/2^{-/-} mice. In addition, cultured cortical astrocytes from S1/2^{-/-} mice display alterations at the morphological and biochemical level which could be of relevance for the observed learning phenotypes. To further characterize regional astrocyte heterogeneity at the molecular level, we acutely isolated GFP tagged astrocytes by FACS from cortex, hippocampus and brainstem and performed transcriptome profiling using next-generation sequencing technology.

Heterogeneity of glial glutamate uptake

Christine Rosemarie Rose¹

¹Heinrich Heine University Duesseldorf, Institute of Neurobiology, Universitaetsstr. 1, Building 26.02, 40225 Duesseldorf, Germany

Glutamate is the major excitatory neurotransmitter of the central nervous system. Upon its release into the extracellular space, it is efficiently removed by high-affinity, sodium-dependent glutamate transporters, located at neuronal and glial plasma membranes. Astrocytes, which express the glutamate transporters GLAST/EAAT1 (glutamate -aspartate transporter/excitatory amino acid transporter 1) and GLT-1/EAAT2, account for the majority of the glutamate uptake activity in the brain. Glial glutamate uptake results in a fast decline in the extracellular glutamate concentration, shapes the time course of synaptic conductance, contributes to the input specificity of glutamatergic synapses, and prevents excitotoxicity. Furthermore, activation of glutamate uptake is accompanied by long-lasting intracellular sodium transients in astrocytes in situ that can spread to neighbouring astrocytes by diffusion through gap junctions composed of Cx30/Cx43.

Earlier studies showed that in the hippocampus and cerebellum GLAST and GLT-1 transporters are located close to synapses and at a lower level at perivascular astrocyte endfeet and established a general increase in glutamate transporter expression from birth to adulthood. Because astrocytes are decidedly polarized cells, with delicate perisynaptic processes contacting synapses on one side and highly specialized endfeet contacting blood vessels on the other, glutamate transporter expression might be heterogeneous not only in respect to development, but also at the cellular and subcellular level. We therefore characterized the laminar and subcellular protein expression profile of GLAST and GLT-1 in the hippocampus of mice during the first 2 months of postnatal development using immunohistochemistry and western blot analysis. While confirming the reported increase in overall GLAST expression during the first two weeks after birth, we found that up-regulation of GLT-1 protein levels was completed only at P20-25 and thus delayed by about ten days. In addition, GLAST and GLT-1 showed differential temporal, laminar and subcellular expression profiles. GLAST increased steadily with highest transporter density in neuronal cell body layers and was preferentially expressed in astrocytes at P3-5 and by radial glia. GLAST immunoreactivity was distributed rather homogeneously with no preferential localization to a specific cellular compartment (Figure, top row). GLT-1 expression was especially prominent in adult tissue. Starting at P10-15, GLT-1 exhibited a laminar expression pattern, with highest immunoreactivity in the stratum lacunosum-moleculare. GLT-1 was only sparsely located at astrocyte somata (Figure, bottom row), whereas it exhibited discrete clusters at perisynaptic processes and at endfeet on blood vessels. Taken together, our results reveal a distinct temporal, laminar as well as subcellular heterogeneity of GLAST and GLT-1 expression in the developing hippocampus. This indicates that the two transporters might serve specialized functional roles in different subcellular domains during formation and maintenance of the hippocampal network.

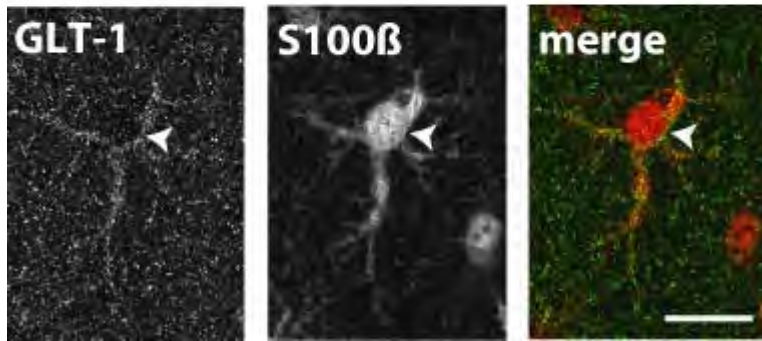
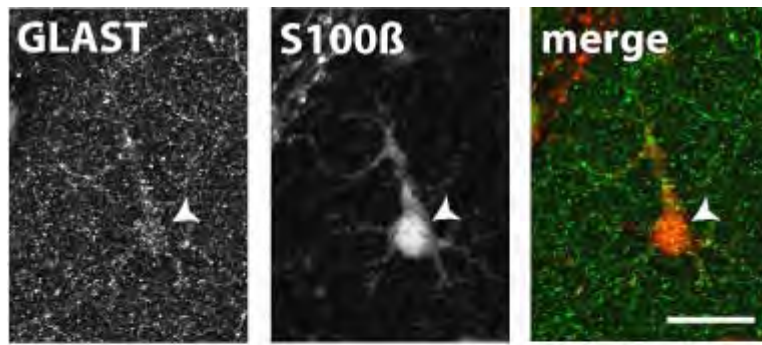

Role of protein translation for astroglial heterogeneity in hippocampal and cortical astrocytes

Daniela Christiane Dieterich¹

¹Otto-von-Guericke University Magdeburg, Institute for Pharmacology and Toxicology, Leipziger Strasse 44, 39120 Magdeburg, Germany

& Leibniz Institute for Neurobiology, Magdeburg,
Brenneckestrasse 6, 39118 Magdeburg, Germany

Recent work from several groups suggests that astrocytes directly influence the formation, function, and stability of synapses, thereby sculpting axonal and dendritic morphology and balancing the activity levels of neurons. Astroglial heterogeneity and its morphological, physiological and molecular consequences within and across different brain regions such as the hippocampus or somatosensory cortex might be one possibility of how these processes might be implemented. On the molecular level astroglial heterogeneity can be reflected by the repertoire of translated mRNAs and the corresponding proteins. Therefore, we are looking at astroglial heterogeneity by performing cell-selective proteomic profiling of astrocytes in conjunction with transcript analysis in different cultures systems. For our investigations on the proteome level we employ a suite of recently developed tools using small chemical reporters to metabolically label newly synthesized proteins. The core of these metabolic labeling techniques capitalizes on the manifold potential of small bioorthogonal chemo-selective groups, such as the azide group. These groups deliver unique chemical functionality to their target molecules, which can subsequently be tagged with exogenously delivered probes for detection or isolation in a highly selective manner. To identify and visualize the subpopulation of newly synthesized protein by BONCAT and FUNCAT the non-canonical amino acid Azidohomoalanine is used in conjunction with click chemistry utilizing the cell's own translation machinery. To tackle questions concerning different cell -types in a complex cellular environment, such as neuron-astroglia networks, we refined BON- and FUNCAT to differentiate between two cell types at the same time. Via the expression of a mutant Methionine-tRNA-synthetase (MetRS) under the control of a cell-specific promoter, the proteome of this cell type can be metabolically labeled with Azidonorleucine (ANL), an artificial amino acid that is excluded by the wild-type MetRS. Identified candidate proteins are validated both by Western Blot and by fluorescent in situ hybridization techniques. Furthermore, protein and transcript data are collected in an astroglia-specific database.

This work is supported by the DFG (Emmy Noether Program, SPP1172 and a DIP grant to DCD).

Altered synaptic plasticity and rhythmic oscillations in the hippocampus following vascular injury and blood-brain barrier dysfunction

Kristina Lippmann¹, Lyn Kaminstky², Svetlana Lublinsky², Julia Nichtweiß¹, Alon Friedman^{1,2}, Uwe Heinemann¹

¹Institute of Neurophysiology, PG Uwe Heinemann, Charitéplatz 1, 10117 Berlin, Germany; ²Department of Physiology, Faculty of Health Sciences, Ben-Gurion University of the Negev, 84105 Beersheva, Israel

Recent studies demonstrated that breakdown of the blood-brain barrier (BBB) is a major factor influencing the outcome of patients who suffer from stroke. It may have an impact on development of neuronal dysfunction, epileptogenesis and delayed neurodegeneration. A crucial mechanism is the activation of the TGF- β pathway in astrocytes through albumin exposure and a subsequent development of an hyperexcitable network. We investigated the hippocampus, an area of high cognitive functions, following cortical photothrombosis regarding the expansion of the BBB breakdown and electrophysiological alterations. We quantified hippocampal BBB dysfunction using Evans blue injections and MRI imaging from 12 h up to 1 week following treatment. Further on we confirmed a slight increase of intracranial pressure within the first 5 h post-stroke which might be one of the reasons for spreading BBB breakdown into the hippocampus following cortical stroke. Ex vivo electrophysiological recordings from area CA1 showed increased likelihood of spontaneous paroxysmal activity, lower threshold for spreading depolarization, reduced long-term potentiation and tendentially decreased GABA A mediated feedback inhibition. In vivo intrahippocampal recordings presented enhanced oscillatory activity after treatment. Our results imply significant hippocampal dysfunction in the presence of peri-ischemic vascular injury contributing to cognitive dysfunction in vascular pathologies.

Molecular Mechanisms of Astrocyte Vesicle Release at Synaptic Interfaces

Anne Christine Wolfes¹, Camin Dean¹

¹European Neuroscience Institute Göttingen, Trans-synaptic signaling, Grisebachstraße 5, 37077 Göttingen, Germany

The release of transmitter molecules (e.g. ATP, glutamate) and mediators of synaptic plasticity (e.g. Hevin, SPARC) has recently been reported for astrocytes, suggesting direct involvement in neuronal function by astrocytes at tripartite synapses. Since the release mechanism of astrocytic factors is unknown, my project aim is to study astrocytic synaptotagmins (SYTs), which are essential for endo- and exocytosis of vesicles, and thus good candidates for a central role in astro-neuronal signalling.

All 17 SYT isoforms include Ca²⁺-binding domains, many of which induce vesicle fusion with the plasma membrane in response to Ca²⁺ influx. Moreover, homologs of neuronal SNARE complex proteins exist in astrocytes, like SNAP23 and VAMP3. Having already found particular SYT isoforms in astrocytes, I will also investigate the presence and function of other astrocytic vesicle proteins.

Data I previously gained from immunocytochemistry and Western blots will be complemented by immunohistochemical analysis of mouse brain slices in which GFP is expressed exclusively in astrocytes. Thus, the localisation of SYTs will be characterised *in vitro* and *in vivo* at different spatial (anatomical, cellular, and molecular) levels and developmental points in astrocytes, as well as their localisation to distinct vesicle sub-types.

For functional analysis, total internal reflection fluorescence microscopy (TIRFM) combined with pHluorin-coupled SYTs will be used. The pH-sensitivity of pHluorins indicates if a vesicle is within a cell (i.e. pH < 5), or fused with the membrane (i.e. pH > 5 extracellularly). To examine vesicle fusion kinetics exclusively at the membrane, pHluorin-coupled SYTs will be expressed in astrocytes of co-cultures of neurones and astrocytes, and compared to data already obtained from astrocyte monoculture experiments, to determine if astrocytic vesicle recycling occurs adjacent to neuronal synapses as part of "tripartite synapses". Subsequently, neuronal networks and the effect of knockout or knockdown of specific astrocytic SYTs will be analysed.

Further, wild-type neurones will be plated on astrocytes derived from knockout mice lacking particular SYT isoforms and used for electrophysiological analysis. Since common neurological disorders such as epilepsy, migraine, and headache are linked to dysfunctional astrocytes, phenotypic analysis of SYT knockout mice will be performed to identify defects in synaptic transmission, plasticity, and overall circuit function of the brain.

Symposium

S21: Molecular mobility, a variable of neuronal communication

- S21-1** Assembly of functional post-synapses by neurexin-neuroligin adhesions: role of lateral diffusion
Olivier Thoumine, Gregory Giannone, Magali Mondin, Katalin Czondor, Mikael Garcia, Martin Heine, Renato Friscknecht, Jean-Baptiste Sibarita, Daniel Choquet
- S21-2** Membrane dynamics of the K⁺/Cl⁻ co-transporter KCC2: a novel, activity-dependent mechanism of neuronal chloride homeostasis
Sabine Lévi
- S21-3** From transmission to connection, a study in GABAergic synapse
YU FU
- S21-4** Competition of Glycine and GABA receptors for scaffolding binding sites at spinal cord inhibitory synapses
Marianne Renner, Antoine Triller
- S21-5** Calcium channel dynamic in the neuronal membrane
Martin Heine, Johannes Kohl, Ulrich Thomas, Romy Schneider

Assembly of functional post-synapses by neurexin-neuroigin adhesions: role of lateral diffusion

Olivier Thoumine¹, Gregory Giannone¹, Magali Mondin¹, Katalin Czondor¹, Mikael Garcia¹, Martin Heine², Renato Friscknecht², Jean-Baptiste Sibarita¹, Daniel Choquet¹

¹CNRS - University of Bordeaux, Interdisciplinary Institute for Neuroscience, 146 rue Léo saignat, 33077 Bordeaux, France

² Leibniz Institute of Neuroscience, Magdeburg, Germany

Neurexin/neuroigin adhesion plays a key role in synaptogenesis, but the mechanisms linking initial contact to the assembly of functional synaptic complexes remain unclear. Using biomimetic systems and high resolution microscopy in cultured neurons, we have demonstrated a multi-step mechanism of excitatory post-synapse differentiation triggered by neurexin neuroigin adhesion. Using neurexin-coated fluorescent nanoparticles, we first demonstrated a very stable adhesion between neurexin and neuroigin (Saint-Michel et al., *Biophys J*, 2009). Second, using neurexin clusters and fluorescence imaging, we have shown that the recruitment of the essential scaffold protein PSD-95 is dependent on the phosphorylation of a critical tyrosine residue in neuroigin-1 (Giannone et al., submitted). Third, using single nanoparticle tracking, we showed that surface-diffusing AMPA receptors are captured in 30 min at PSD-95 scaffolds assembled by neurexin/neuroigin adhesions (Mondin et al., *J Neurosci* 2011), and that these receptors are functional (Heine et al., *PNAS* 2008). Based on these data, we generated computer simulations integrating the two major mechanisms of AMPA receptor delivery at synapses, namely surface diffusion and recycling from internal stores (Czöndör et al., *PNAS* 2012). This model provides new insights on the dynamic regulation of synaptic strength.

Membrane dynamics of the K⁺/Cl⁻ co-transporter KCC2: a novel, activity-dependent mechanism of neuronal chloride homeostasis

Sabine Lévi¹

¹INSERM UMR839, Institut du Fer à Moulin, 17 rue du Fer à Moulin, 75005 Paris, France

The neuronal K⁺/Cl⁻ cotransporter KCC2 extrudes intracellular Cl⁻ and therefore determines the polarity of GABA signaling in the brain. Loss of KCC2 expression has been observed in epilepsy. However, KCC2 expression does not always correlate with intraneuronal Cl⁻ concentration, suggesting the transporter function might be altered independent of its expression level. KCC2 form clusters near synapses. This is reminiscent of postsynaptic receptor clusters formed by a diffusion-trap mechanism. We propose the regulation of lateral diffusion and clustering may affect the net function of KCC2. This will be a mechanism to locally and rapidly modulate the number of transporters near inhibitory synapses and therefore Cl⁻ ion efflux.

To address this question, we have studied the lateral diffusion of KCC2 in mature hippocampal neurons with Single Particle Tracking. These experiments revealed KCC2 free diffusion in the extrasynaptic compartment and lower mobility and increased confinement near synapses. Furthermore, epileptiform activity rapidly increased lateral diffusion, decreased clustering, and reduced activity of KCC2; suggesting regulation of diffusion may affect the net function of the transporter.

This work represents the first characterization of the diffusion dynamics of an ion transporter that may be generalized to other transporters and may reveal a new level of regulation of neuronal chloride homeostasis and therefore efficacy and/or polarity of the inhibitory synaptic transmission.

From transmission to connection, a study in GABAergic synapse

YU FU¹

¹University of California San Francisco, Physiology, Rm436 685 Nelson Rising Lane, 94158 San Francisco, USA

Accumulating evidence indicate that GABA regulates activity -dependent development of inhibitory synapses in the vertebrate brain, but the underlying mechanisms remain unclear. Here we combined live imaging of cortical GABAergic axons with single cell genetic manipulation to dissect the role of presynaptic GABAB receptors (GABABRs) in inhibitory synapse formation in mouse. Developing GABAergic axons form a significant number of transient boutons but only a subset was stabilized. Synaptic vesicles in these nascent boutons are often highly mobile in the course of tens of minutes. Activation of presynaptic GABABRs stabilized mobile vesicles in nascent boutons through the local enhancement of actin polymerization. Inactivation of GABABRs in developing basket interneurons resulted in aberrant pattern of bouton size distribution, reduced bouton density and reduced axon branching, as well as reduced frequency of miniature inhibitory currents in postsynaptic pyramidal neurons. These results suggest that GABABRs along developing inhibitory axons act as a local sensor of GABA release and promote presynaptic maturation through increased recruitment of mobile vesicle pools. Such release-dependent validation and maturation of nascent terminals is well suited to sculpt the pattern of synapse formation and distribution along axon branches.

Competition of Glycine and GABA receptors for scaffolding binding sites at spinal cord inhibitory synapses

Marianne Renner¹, Antoine Triller¹

¹Institut de Biologie de l'Ecole Normale Supérieure (IBENS), Inserm U1024, CNRS UMR8197, 46 rue d'Ulm, 75005 Paris, France

Neuronal synapses are dynamic membrane domains. Receptors are exchanged between extrasynaptic and synaptic membranes by lateral diffusion, thus the capacity of the synapse to trap (stabilize) receptors underlies the formation of the synaptic domain and determines the synaptic strength by controlling the number of receptors at the post-synaptic membrane. At inhibitory synapses of cultured spinal cord neurons, glycine (GlyR) and GABA_A receptors (GABA_AR) are both present in the majority of postsynaptic membranes, being stabilized by the scaffolding molecule gephyrin. Indeed, both types of receptors bind to nearby sites on the gephyrin molecule albeit with different affinities. Early-formed synapses contain GABA_ARs but not GlyRs, which are recruited later. I use single particle tracking to study the diffusion and stabilization of these receptors along synaptic maturation. The single molecule approach allows the study of changes in the diffusive behaviour that raise from molecular interactions and their kinetics in cellulo. I present a new parameter, the "packing coefficient", which detects stabilization events along a trajectory. Interestingly, receptors often jump from one stabilization site to another. This can be an indication of the morphing of the scaffold or that receptors establish interactions with different gephyrin sites during their stay at the synapse. In agreement with the higher affinity of GlyR for gephyrin, synapses are overall more efficient to stabilize GlyR than GABA_AR, with the exception of GABA_ARs containing the alpha 1 subunit which are the most stabilized in young neurons. More importantly, two lines of experiments as well as Monte Carlo simulations strongly suggest that the stabilization of GABA_AR is dependent on the degree of stabilization of GlyR, as both receptors compete for their scaffolding sites. This contributes to differential regulations of GlyR and GABA_AR at same inhibitory synapses.

Calcium channel dynamic in the neuronal membrane

Martin Heine¹, Johannes Kohl^{1,2}, Ulrich Thomas¹, Romy Schneider¹

¹Leibniz Institute for Neurobiology, Magdeburg, Germany ²MRC Laboratory of Molecular Biology, Cambridge, UK

Synaptic release probability is influenced by the alignment of pre- and postsynaptic membranes as well as the local density of presynaptic calcium channels and postsynaptic receptors. High voltage gated calcium channel location is most critical for the success of transmitter release and hence determines the synaptic variability on the presynaptic side. Those channels are composed of three subunits, the pore forming alpha1 subunit, the intracellular beta-subunits and extracellular alpha2delta subunits. Beta- and alpha2delta-subunits do influence the intracellular trafficking as well as biophysical properties of calcium channels complexes in the membrane. Their location in the neuronal membrane has been suggested to be very confined due to the action potential induced transient opening of calcium channels and the moderate affinity of calcium sensitive SNARE proteins. A confined mobility within the presynaptic membrane or a dynamic interaction of the channel subunits could substantially alter presynaptic release properties. To visualise this possible dynamic of channel subunits in the presynaptic membrane we have used single particle tracking (SPT) and photo activated localization microscopy (PALM). The pore forming subunits of CaV 2.1 and CaV 2.2-channels appeared to be strongly confined within the synapse, whereas the extracellular GPI-anchored alpha2delta-subunits are highly mobile in the axonal membrane and only partially confined within the synapse. Testing different combinations of alpha1- and alpha2delta-subunits demonstrated large differences in the interaction between subunits. In line with the different subunit affinities and ability to tune channel opening properties a modulation of the surface expression of alpha2delta subunits in cultured hippocampal impact on synaptic activity. We suggest that the molecular dynamic of alpha1- and alpha2delta subunits does tune synaptic transmission based on molecular surface dynamic.

Symposium

S22: Insect motor control- From ion channels to learning, movement and robotics

- S22-1** From Ion Channels to Function, Behavior, and Speciation
Stefanie Ryglewski, Dimitrios Kadas, Carsten Duch
- S22-2** Opportune wiring of motor circuits during development of *Drosophila*
Jan Felix Evers, Louise Couton, Temur Yusunov, Sören Diegelmann, Matthias Landgraf
- S22-3** Motor Flexibility In Insect Locomotion: Changing Walking Direction
Katja Hellekes, Matthias Gruhn, Ansgar Büschges
- S22-4** Single perturbations cause sustained changes in searching behavior of stick insects.
Eva Berg, Joachim Schmidt, Ansgar Büschges
- S22-5** Learning improves complex motor behaviors
Tammo Krause, Roland Strauss
- S22-6** Two Classes of Steps Revealed by the Natural Statistics of Locomotion
Leslie M. Theunissen, Holger H. Bekemeier, Volker Dürr
- S22-7** A neural basis for spatial coordination of limbs: descending interneurons in the stick insect antennal mechanosensory system
Jan Marek Ache, Volker Dürr

From Ion Channels to Function, Behavior, and Speciation

Stefanie Ryglewski¹, Dimitrios Kadas², Carsten Duch³

¹Johannes Gutenberg University Mainz, Department of Neurobiology, Colonel-Kleinmann-Weg 2, 55128 Mainz, Germany

²Arizona State University, Tempe, Arizona 85287, USA

³Johannes Gutenberg University Mainz, Department of Neurobiology, Colonel-Kleinmann-Weg 2, 55128 Mainz, Germany

Voltage gated calcium channels (VGCCs) carry out diverse functions in different types of neurons and different brain parts. In vertebrates 10 genes encode for VGCC alpha subunits. These comprise three different families, Ca_v1 channels which mediate high voltage activated (HVA) L-type currents, Ca_v2 channels which mediate HVA P-/Q-, N-, and R-type calcium currents, and Ca_v3 channels, which mediate low voltage activated (LVA) T-type channels. In the *Drosophila melanogaster* genetic model system each of these families is represented by only one gene, namely Dmca1A (Ca_v1 homolog), Dmca1D (Ca_v2 homolog), and DmaG (Ca_v3) homolog. We employ targeted genetic manipulation of these calcium channels in identified *Drosophila* motoneurons to (i) test which *Drosophila* channels underlie which calcium currents, (ii) test the function of these channels for generating correct firing patterns in larval crawling versus adult flight and courtship song, and to probe (iii) calcium channel function in speciation. As is the case in mammalian motoneurons, in larval *Drosophila* crawling motoneurons Ca_v1 channels (Dmca1D) mediate somatodendritic L-type calcium currents which may serve to boost synaptic drive to their dendrites, especially in the presence of aminergic modulation. By contrast, adult flight/courtship motoneurons express somatodendritic LVA T-type like and HVA N-type like calcium currents, as well as presynaptic P-/Q-type calcium current, all three of which are mediated by the Ca_v2 homolog, Dmca1A. Therefore, at least 3 different calcium currents are mediated by one gene in the same neuron. *Dmca1A*, also named *cacophony*, is alternatively spliced and A-I RNA edited. This results in more than 1000 possible cacophony protein variants, 22 of which we have identified in the *Drosophila* brain by RNA Seq. However, expression of just one cacophony transcript in a null background can rescue all three calcium currents in adult motoneurons. Therefore, interactions with other subunits or posttranslational modifications must create LVA or HVA VGCCs from one transcript, and this is currently under investigation.

However, our data show that larval crawling versus adult flight and courtship song require different VGCCs in motoneurons. Interestingly, mutations in *cacophony* that affect adult motoneuron HVA and LVA somatodendritic calcium currents also affect male courtship song. Song is produced by wing movements at species specific frequencies, which in turn are affected by cacophony based currents in motoneurons. Therefore, altered cacophony based motoneuron calcium currents may serve prezygotic isolation. With more than 1000 possible transcript variants, the *cacophony* gene provides a suitable substrate for soft selection, and most importantly, altered *cacophony* transcripts will also affect the neural basis of audition, so that mutations affect the sender as well as the receiver. We now produce different *cacophony* splice variants in a null background to test the function of each one for motoneuron calcium currents, courtship song, and mating success.

Opportune wiring of motor circuits during development of *Drosophila*

Jan Felix Evers¹, Louise Couton², Temur Yusunov², Sören Diegelmann², Matthias Landgraf²

¹University of Cambridge, Dept. of Physiology, Development and Neuroscience, Downing Street, CB2 3DY Cambridge, United Kingdom

²University of Cambridge, Dept. of Zoology, Downing Street, CB2 3EJ Cambridge, United Kingdom

The *Drosophila* nervous system is well known for its stereotypic development of its constituent neurons. Much less is known about how these elements connect to form functional circuits. Recent results have shown that activity dependent mechanisms homeostatically adjust neuronal growth in the embryonic CNS and regulate the emergence of coordinated behaviour. Our aim is to study how actual patterns of synaptic connections are generated as networks develop. To be able to this at the level of single identified neurons, we generated tools to independently label identified cholinergic inter- and sensory neurons (split-GAL4) and motorneurons (LexA). Bimolecular fluorescence complementation (GRASP) allows us to identify molecular contact between these neurons; co-localisation with presynaptic release sites (bruchpilot-mRFP) to pinpoint synaptic contacts.

Using these tools we find that:

1. Variable numbers of synaptic sites form between individual pairs of inter- and motorneurons;
2. Synapse numbers between connecting neurons increase with developmental age;
3. Connections between sensory and motor neurons are highly variable at larval hatching, but this variability decreases during larval development.

Our data suggest that synaptogenesis in the embryonic and larval nervous system may be rather opportunistic. We speculate that the amount of overlap of projection areas is an important regulator for the number of synaptic contacts formed. We are now testing this hypothesis experimentally.

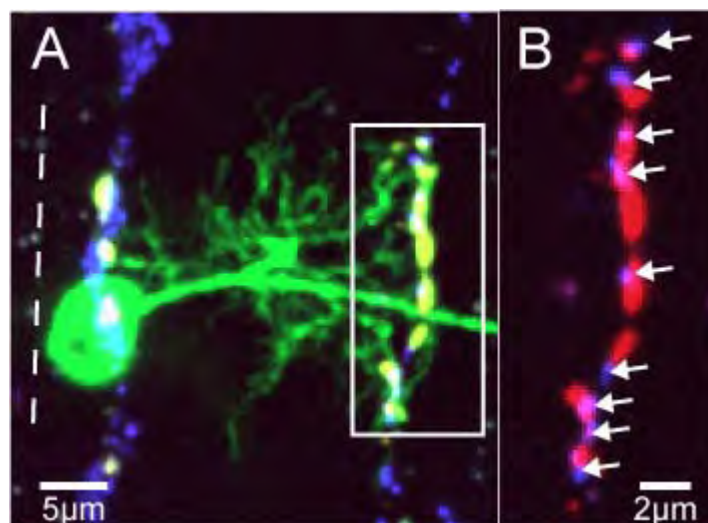

Motor Flexibility In Insect Locomotion: Changing Walking Direction

Katja Hellekes¹, Matthias Gruhn², Ansgar Büschges³

^{1,2,3}Biocenter, University of Cologne, Department of Animal Physiology, Zülpicher Str. 47b, 50674 Cologne, Germany

Today, organization and operation of those neural networks that contribute to the generation of a basic stepping motor output, in particular in stick insect and cat, are clear to some detailed extent (Pearson et al. 2006; Gruhn & Büschges, 2008). However, this understanding is mostly restricted to motor activity for straight walking only, while the neural basis of motor flexibility, i.e. the generation of different walking directions, curve walking or even climbing, is still barely understood (Büschges, 2012). Recently, we have addressed this issue in a series of studies to analyze the generation of curve walking. The talk will present our present knowledge on those neural interactions underlying the generation of leg stepping in a curve walking stick insect: (i) Using a preparation with reduced mechanical coupling between the legs (Gruhn et al. 2009) has revealed that the individual legs each contribute to the generation of curve walking by generating leg and task specific kinematics, independent of mechanical coupling between them, but also independent of the presence of the other legs: stance of the inside middle leg (iL) is mainly produced by tibial flexion that pulls the animal into the curve, while stance of the outside leg (oL) is mainly generated through retraction of the fairly extended middle leg. (ii) Processing of movement signals from the tibia, known to contribute to the control of tibial motoneuron activity, contributes to generating the observed differing leg kinematics in iL and oL: while flexion signals from the tibia in an iL reinforce flexor motoneuron activity no such influence was detected for oL (see Hellekes et al. 2012; see also Poster by Hellekes and Büschges). (iii) Task dependent influences between leg controller operation of iL and oL were also detected for the segmental central pattern generating networks: while on the oL side, coxal motoneuron activity was mostly tonic and shifted towards retractor coxae activity, on the iL side both antagonistic coxal motoneurons were rhythmically active in-phase with front leg stepping (see also Poster by Gruhn et al.). From these results the notion arises that motor flexibility of locomotor systems is based on specific, fine-tuned modifications in the operation of the segmental locomotor networks. Supported by DFG grants Bu857/10 and 11 in PAK146.

Single perturbations cause sustained changes in searching behavior of stick insects.

Eva Berg¹, Joachim Schmidt¹, Ansgar Büschges¹

¹Department of Animal Physiology, Biocenter, University of Cologne, Zùlpicherstr. 47b, 50674 Cologne, Germany

Walking stick insects that do not find a foothold perform stereotypic cyclic searching movements (SMs) with the respective leg (Bässler, 1993; Dürr, 2001). When encountering an object, the animals grasp it. We are interested in the control of SMs that are continued after a one-time leg contact with an object that is removed immediately after contact. Experiments were performed on stick insects (*Cuniculina impigra*) with a single intact leg that was restrained to move in the vertical plane. A stick was moved into the leg's movement path such that it was touched one time by the distal tibia. After touching, animals (i) shifted their SMs towards the position of contact and (ii) significantly decreased SM amplitudes. Over a period of on average six seconds the movements shifted back to the initial position accompanied by a simultaneous increase in amplitude. Because this targeted response outlasts a single stimulus by several seconds it could be considered to involve a short term memory. The targeted response was generated by changes in movements of both coxa -trochanter- and femur -tibia-joint. However, the stereotypic coordination of joint movements was preserved in targeted searching movements. We explore the neuronal mechanisms underlying searching movements and the targeted response by intracellularly recording leg moto- and premotor interneurons. It appears that particularly local nonspiking-interneurons (NSIs) can control searching movements. For example, individual NSIs, when depolarized, lead to initiation of searching movements. Other NSIs influence specific parameters of searching movements. For example, a NSI that lead to an extension of the tibia when depolarized, influenced the amplitudes of searching movements: by de- or hyperpolarizing the NSI for the time of several searching cycles, the amplitudes of searching movements in the femur-tibia-joint were decreased or increased, respectively. Currently, we investigate the role of specific NSIs in the generation of searching movements and the targeted response that we observe.

Learning improves complex motor behaviors

Tammo Krause¹, Roland Strauss¹

¹Johannes Gutenberg University Mainz, Zoology Neurobiology, Colonel Kleinmannweg 2, 55099 Mainz, Germany

Here we show that flies visually estimate the size of chasms in their way and engage in costly climbing behavior only when they see a fair chance to surmount the gap (Pick & Stauss 2005). Body size in fruit flies is not entirely genetically determined but depends also on environmental factors like food quality, larval density and temperature regime. A 15% size variation is easily found among flies with the same genetic background. Experienced small flies know about their disadvantage, because they abandon attempts on gaps that their larger siblings from the same set of vials still attempt to climb. Freshly hatched flies overestimate themselves but calibrate their decisions according to their actual body size gathered from the visual feed-back of the retinal images of contrast edges during normal locomotion (parallax motion). This is shown by exposing dark-reared flies to defined environments with dark and bright stripes of selected pattern wave lengths. Climbing is not required for the calibration process. Indeed, the decisions of learning defective *dunce*¹- and *rutabaga*¹- flies are independent of their individual size. They try to overcome chasms which are clearly impossible to cross suggesting that the information of body reach depends on the cAMP cascade. Mutant analysis and differential rescue experiments via the GAL4/UAS- system revealed that this process is regulated by cAMP/PKA signaling and activation of the transcriptional regulator CREB (Zars et al. 2000). The *rutabaga* encoded adenylyl cyclase is not needed during the developmental stages. It is sufficient for the rescue of the behavioral phenotype to provide *rutabaga* just acutely via GAL80^{ts}-constructs (Mc Guire et al. 2003) during the adult stage. Moreover, we have identified two sets of neurons in the central complex of *Drosophila* that are involved in memorizing the peripersonal space of a fly.

This work is supported by EMICAB, an EU-funded project within FP7-ICT Cognitive Systems and Robotics (grant 270182).

References:

- McGuire SE, Le PT, Osborn AJ, Matsumoto K, Davis RL (2003) Spatiotemporal rescue of memory dysfunction in *Drosophila*. *Science* 302:1765-1768.
- Pick S, Strauss R (2005) Goal-driven behavioral adaptations in gap-climbing *Drosophila*. *Curr Biol* 15:1473-1478.
- Zars T, Fischer M, Schulz R, Heisenberg M (2000) Localization of a short-term memory in *Drosophila*. *Science* 288: 672-675.

Two Classes of Steps Revealed by the Natural Statistics of Locomotion

Leslie M. Theunissen^{1,2}, Holger H. Bekemeier^{1,2}, Volker Dürri^{1,2}

¹Bielefeld University, Biological Cybernetics, Universitätsstr. 25, 33615 Bielefeld, Germany

²CITEC - Cognitive Interaction Technology - Center of Excellence, Bielefeld University, Universitätsstr. 25, 33615 Bielefeld, Germany

Locomotion is controlled by a combination of central pattern generating mechanisms and sensory mediated feedback. For analysing their relative contribution to natural stepping patterns, we need to understand the behavioural variability of unrestrained locomotion. For example, insects often walk regularly on horizontal surfaces, but stepping patterns become more variable during curve walking (Dürri, 2005, J.Exp.Biol. 208:2253-2267), gap crossing (Bläsing and Cruse, 2004, J.Exp.Biol. 207:1273-1286) and climbing (Watson et al., 2002, J.Comp.Physiol.A 188:39–53). Here, we seek to identify features in step parameter distributions that are invariant across species and leg types, but differentially affected by behavioural context. Therefore, we recorded three species of stick insects (*Carausius morosus*, *Arctopis asperimus* and *Medauroidea extradentata*) during unrestrained walking and climbing on staircases of different height, using a Vicon motion capture system. The data allowed us to reconstruct the whole-body kinematics for several hours worth of unrestrained locomotion sequences, including the movement of all three thorax segments, the head, eighteen leg joints, and the two antennae. The data were stored in an SQL-based natural movement data base, using a generic entity relationship model for easy interface with Matlab. Four walking/climbing conditions were used to assess the effect of walking condition on kinematic parameters.

The first invariant feature we found is two distinct classes of steps. Step length distributions showed always two peaks, independent of species or leg type. Using the local minimum between the two peaks, step length distributions were separated into two classes of steps: short and long steps. The bimodal distribution was well-described by the sum of a Gamma and a Logistic distribution for the modes corresponding to short and long steps, respectively. Major parameters of both distribution functions varied only little with walking condition, but the proportion of the two classes of steps changed: The higher the stairs, the more short steps were observed. Their spatial occurrence and their different timing suggested that short steps have different functional properties than long steps. Short steps were observed most often near the edges of the stairs and typically occurred after very short ground contact. Furthermore, their lift-off positions were located in the anterior third of the leg's workspace. Step direction of short steps was very variable and dependent on the lift-off position, whereas long steps were always directed anteriorly. From their different functional and statistical properties, we conclude that stick insects take two distinct classes of steps during locomotion, suggesting distinct underlying control mechanisms, i.e., different involvement of central pattern generating mechanisms and proprioceptive feedback. Owing to their prevalent occurrence after short stance periods, their anterior lift-off position and variable step direction, we propose that short steps serve as corrective steps that strongly depend on sensory feedback.

Supported by EU-project EMICAB (FP7-ICT-270182)

A neural basis for spatial coordination of limbs: descending interneurons in the stick insect antennal mechanosensory system

Jan Marek Ache¹, Volker Dürr^{1,2}

¹Bielefeld University, Biological Cybernetics, Universitätsstr. 25, 33615 Bielefeld, Germany

²CITEC - Cognitive Interaction Technology - Center of Excellence, Bielefeld University, Universitätsstr. 25, 33615 Bielefeld, Germany

Many animals rely on their tactile sense for near-range orientation during locomotion. For example, climbing stick insects (*Carausius morosus*) can adjust the touch-down positions of their front legs to antennal contact positions on the obstacle climbed (Schütz & Dürr, *Phil.Trans.R.Soc.B*, 2011). The spatial coordination of antennae and legs provides a suitable experimental paradigm for investigating the neural basis of an important aspect of adaptive locomotion: inter-segmental coordinate transfer between limbs in general.

Here, we report results from a sample of more than 100 intracellular recordings of descending interneurons (DINs) that mediate antennal proprioceptive information to thoracic networks and, potentially, to the networks controlling leg movement. All DINs were recorded in the neck connectives while the antennal pointing direction was altered by imposing movements of the distal antennal joint (SP joint).

DINs were empirically separated into five groups based on their overall physiological properties: *simple position-sensitive DINs* mediated the SP joint angle, *dynamic position-sensitive DINs* mediated the SP joint angle during SP joint movement, *unspecific movement-sensitive DINs* fired additional spikes during SP joint movement, and *ON- and OFF-type velocity-sensitive DINs* exhibited rises or decays of their spike rate proportional to the SP joint angle velocity.

A data-driven analysis based on Principal Component Analysis (PCA) was used to evaluate the empirical grouping of DINs. For this, PCA was applied to 60 arrays of simple selectivity measures for movement, direction, and position, encoding the response properties of 60 DINs at different SP joint angle velocities. The PCA revealed that the sample of DINs was most selective to antennal movement and position, with direction selectivity being much less pronounced. Many DINs were sensitive to two or more stimulus parameters. Most importantly, the five empirically derived DIN groups also clustered in PC space, supporting the empirical grouping of DINs.

The population of velocity-sensitive DINs was characterized in more detail. OFF-type velocity-sensitive DINs had a high baseline spike rate and were inhibited during SP joint movement, whereas ON-type velocity-sensitive DINs (ONv) had a low baseline spike rate and fired during SP joint movement. ONvs come in ipsilateral (iONv) and contralateral (cONv) descending types, with respect to the stimulated antenna. The spike rates of both types varied linearly with the SP joint angle velocity between 4 and 800°/s. However, iONvs had a higher gain than cONvs. cONv stainings in different animals revealed very similar branching patterns in the prothoracic ganglion, suggesting that the recordings stem from the same DIN. cONv does not respond to ipsilateral antennal inputs, but does respond to substrate vibration. Parallel recordings from cONv and a contralateral OFF-type velocity-sensitive DIN revealed that both DINs responded to SP joint movement in an anticorrelated manner. ON- and OFF-type velocity-sensitive DINs might thus form a push-pull mechanism for monitoring antennal movement velocity.

In summary, our results show that detailed information about antennal movement reaches thoracic networks. This information potentially contributes to spatial coordination of antennae and legs during adaptive locomotion.

Symposium

S23: Purinergic signaling in sensory systems

- S23-1** Influence of purinergic signaling onto the physiology and pathophysiology of retinal (Müller) glial cells
Antje Grosche, Thomas Pannicke, Andreas Bringmann, Andreas Reichenbach
- S23-2** Gliotransmitter release from retinal Müller glial cells
Lysann Wagner, P.G. Haydon, Andreas Reichenbach, Antje Grosche
- S23-3** Purinergic signaling in the cochlea
Gary D. Housley, Rachel Morton-Jones, Ravindra S. Telang, Srdjan M. Vlajkovic, Allen F. Ryan, Peter R. Thorne
- S23-4** Purinergic signalling in the olfactory bulb
Daniela Hirnet
- S23-5** A₁ receptor-mediated modulation of neuronal network activity in the olfactory bulb
Natalie Rotermund
- S23-6** Purinergic signaling in the olfactory epithelium
Colleen Cosgrove Hegg

Influence of purinergic signaling onto the physiology and pathophysiology of retinal (Müller) glial cells

Antje Grosche¹, Thomas Pannicke¹, Andreas Bringmann², Andreas Reichenbach¹

¹Paul Flechsig Institute of Brain Research, Pathophysiology of Neuroglia, Jahnallee 59, 04109 Leipzig, Germany

²Department of Ophthalmology and Eye Clinic, University of Leipzig, Liebigstr. 10-14, 04103 Leipzig, Germany

Müller cells, the principal macroglia cell type of the sensory retina, fulfill typical housekeeping functions such as the maintenance of the extracellular ion- and volume homeostasis. Apart from this, evidence is accumulating that they actively modulate the neuronal information processing by the release of gliotransmitters such as glutamate or purines (in particular, ATP and adenosine). In the pathologically altered retina, Müller cells show typical changes in their physiological characteristics. Their pronounced Kir4.1 channel- mediated potassium conductance is reduced. They lose their capability of a highly efficient cellular volume regulation and show an enhanced calcium response onto ATP-stimulation. Recent studies demonstrate a key role of the Gq11-coupled ATP/ADP-sensitive P2Y1 receptor expressed on Müller cells in the context of all of these processes. Activation of the P2Y1 receptor is essential for an intact volume regulation in healthy Müller cells and its stimulation by application of exogenous ATP restores the capability of volume regulation in gliotic Müller cells. Using an enzyme-linked assay to detect extracellular glutamate, we identified a P2Y1 receptor-dependent ATP-induced glutamate release from single Müller cells which possibly resembles a positive feedback-mechanism in their volume regulatory cascade. Additionally, this ATP-induced glutamate release might serve as basis for glia-neuron-interactions during normal neuronal activity and during deregulated hyperexcitation. Since the ATP response pattern of Müller cells is changed in the diseased retina and the P2Y1 receptor was discussed to regulate the gliotic activation of glia cells, we included P2Y1 receptor- deficient mice in a study on an ischemia/reperfusion model. Indeed, we found evidences of less pronounced gliotic changes in the Müller cell physiology in P2Y1 receptor-deficient mice compared to the wild type controls. While the Kir4.1 potassium channels were significantly down-regulated in wild type animals, they were still functionally expressed at near normal levels in the P2Y1 receptor-deficient mice. These results further support the idea of the P2Y1 receptor directly being involved in the modulation of the Müller cell reaction onto pathological changes in the tissue. Ongoing experiments address the question whether the altered glial activation affects the survival of surrounding neurons.

Taken together, these data underline the importance of purinergic signaling for the physiological functions of Müller cells in the healthy and diseased retina and delineate the P2Y1 receptor and downstream signaling mechanisms as potent targets to manipulate specific Müller cell functions.

Gliotransmitter release from retinal Müller glial cells

Lysann Wagner¹, P.G. Haydon², Andreas Reichenbach¹, Antje Grosche¹

¹Medizinische Fakultät der Universität Leipzig, Paul-Flechsig-Institute for Brain Research, Jahnallee 59, 04109 Leipzig, Germany

²Department of Neuroscience, Tufts University School of Medicine, Boston, Massachusetts, USA

Müller cells, the principal glial cells of the retina, are crucial for the homeostatic and metabolic support of retinal neurons. Furthermore, Müller cells are supposed to modulate neuronal function by glutamatergic and purinergic signalling. A prerequisite for such kind of glia-neuron interaction is a tightly regulated, fast release of transmitters from both neurons and glia cells. Previously, we examined how transmitter release is involved in the volume regulatory signalling cascade of retinal Müller glial cells. Growth factor-stimulated release of glutamate, activation of metabotropic glutamate receptors and subsequent release of adenosine -5'-triphosphate (ATP) are key steps of this pathway. Although the action of these transmitters on Müller cells is well described, little is known about release mechanisms. These experiments provide first evidence that Müller cells are capable to release glutamate via regulated exocytosis, while ATP is set free via alternative pathways. The most probable one appears to be the opening of connexin hemi-channels. To further characterize the glutamate release from Müller cells we used a fluorometric enzyme assay based on the Amplex® Red Glutamic Acid Kit to visualize glutamate release from acutely isolated murine Müller cells. In combination with a transgenic mouse line that expresses a dominant-negative SNARE (dnSNARE) protein to block the vesicular release of transmitters we demonstrate glutamate release via exocytosis and at least one alternative calcium-dependent pathway.

Purinergic signaling in the cochlea

Gary D. Housley^{1,2}, Rachel Morton-Jones², Ravindra S. Telang^{2,3}, Srdjan M. Vlajkovic^{2,3}, Allen F. Ryan⁴, Peter R. Thorne^{2,3,5}

¹Physiology and Translational Neuroscience, School of Medical Sciences, University of New South Wales, UNSW Kensington Campus, NSW 2052 Sydney, Australia, ²Department of Physiology and ³Centre for Brain Research, School of Medical Sciences, University of Auckland, New Zealand, ⁴Departments of Surgery and Neurosciences, University of California San Diego and VA Medical Center, La Jolla, CA 92037, USA, ⁵Section of Audiology, School of Population Health, University of Auckland, Auckland, New Zealand.

There is extensive evidence for expression of many different types of purinergic receptors in the cochlea. These include ionotropic P2X receptors, as well as metabotropic P2Y and P1 (adenoreceptors) receptors, activated by purine and pyrimidine nucleotides and nucleosides (1). Most subtypes of these receptor classes are broadly expressed in the cochlear partition, including the sensory hair cells and supporting cells of the organ of Corti, as well as Reissner's membrane. The P2X₂ receptor is prominent amongst the signal transduction elements strongly expressed in these structures, based upon mRNA and protein localization. This receptor is one of seven P2X subtypes, representing subunits that can form an ATP-gated ion channel via homo- or heteromeric assembly in a trimeric configuration. The P2X₂ receptor type ATP-gated ion channel is characterised by being selectively activated by ATP over other nucleotides and nucleosides and exhibits sustained activation in the presence of ATP, with potent non-selective cation conductance (including Ca²⁺ entry). ATP is known to be released into the cochlea when sound levels are elevated (2), and therefore this ligand is available to activate P2X₂ receptors. Using a transgenic mouse model null for the P2X₂ receptor (P2X2KO), we investigated the potential contribution of the P2X₂ receptor to known purinergic signaling properties in the cochlea. Using whole-cell patch clamp, we characterised the membrane conductances of inner and outer hair cells and Reissner's membrane epithelial cells isolated from the cochleae of wildtype and P2X2KO mice and found a substantial loss of ATP-activated inward currents in the cochlear cells from the knockout mice compared with the controls. Complementing this, we undertook measurements of the cochlear partition resistance in urethane anaesthetised wildtype and P2X2KO mice before, during and after microinjection of ATP into the endolymphatic compartment (facing the apically-localized P2X₂ receptors). We found substantial changes in CoPR in the wildtype mice, but not the P2X2KO mice, suggesting that P2X₂ receptors are a prominent element of the purinergic modulation of the CoPR and endocochlear potential. This is consistent with a role for purinergic signaling in modulating the electrochemical driving force for sound transduction, which likely reduces hearing sensitivity. ATP and other purine and pyrimidine species may complement this signaling via P2Y and P1 receptors to affect hearing function and serve as otoprotective pathways to preserve hearing function with acoustic overstimulation. Experiments were performed with approval from the University of Auckland and University of New South Wales animal ethics committees. Funded by National Health and Medical Research Council of Australia grant 630618 (G.H., A.R.); the Health Research Council of New Zealand and Deafness Research Foundation of New Zealand (P.T., G.H., S.V.); the Marsden Fund (Royal Society of New Zealand) (G.H.) and the VA Research Service and NIH grant DC000139 (A.R.).

1. Housley, G.D., Bringmann, A., Reichenbach, A. Purinergic signaling in special senses. *TINS* 32,128-141 (2009).
2. Muñoz, D. J., Kendrick, I. S., Rassam, M. & Thorne, P. R. Vesicular storage of adenosine triphosphate in the guinea-pig cochlear lateral wall and concentrations of ATP in the endolymph during sound

exposure and hypoxia. *Acta Otolaryngol* 121, 10-15. (2001).

Purinergic signalling in the olfactory bulb

Daniela Hirnet¹

¹University of Hamburg, Neurophysiology, Biocentre Grindel, Martin-Luther-King Platz, 20146 Hamburg, Germany

The olfactory bulb is one of the brain regions with the highest expression of proteins belonging to the purinergic transmitter system, yet it is not much known about the role of ATP and its metabolites in cellular communication or signal processing in this area. We could show that purines exert their functions at different levels of the olfactory pathway. Recently, we demonstrated that ATP is released along the axons of the olfactory receptor neurons on the way to their target glomeruli. This ectopic release, far away from any synapse, activates olfactory ensheathing glia in the adjacencies which are thought to support the axonal outgrowth and path-finding of newly built sensory neurons. Furthermore, ATP is used by the sensory neurons at the nerve terminal as co-transmitter with glutamate and activates astrocytes of the glomerular layer via P2Y1 receptors. In addition, ATP is degraded to adenosine and activates astrocytic A2A receptors. However, ATP is not only a regulator of neuron-glia interaction in the olfactory bulb, but is also modulating neuronal communication. We could reveal the sensitivity of the neuronal network to purinergic tuning by photolytic release of caged ATP, mimicking synaptic ATP release. The activation of P2Y1 receptors on glutamatergic neurons leads to an increase of network-activity, suggesting a role of the co-transmitter ATP in the regulation of the susceptibility of the network to incoming signals. On the other hand, we could demonstrate that after degradation to adenosine and activation of A1 receptors on mitral cells, the network activity is dampened, implying a bidirectional role of ATP and its metabolites in fine-tuning the processing of sensory signals.

A₁ receptor-mediated modulation of neuronal network activity in the olfactory bulb

Natalie Rotermund¹

¹University of Hamburg, Neurophysiology, Martin-Luther-King Platz 3, 20146 Hamburg, Germany

Neuromodulation by ATP, ADP and adenosine is unique with regard to its complexity and specificity, achieved by tissue-specific combinations of transmitters with a variety of receptor subtypes, second messenger systems, transporters and enzymes. ATP and its metabolites, in particular adenosine, are ubiquitous co-transmitters and neuromodulators, participating in synaptic transmission as well as in neuron-glia interactions. Proteins associated with the purinergic signalling system are highly expressed in the olfactory bulb of rodents, suggesting purinergic modulation of olfactory information processing. In the present study, we focus on the effect of adenosine on the neuronal network activity in the olfactory bulb. We monitored the activity of olfactory bulb neurons by recording postsynaptic whole-cell currents of mitral cells, the output neurons of the olfactory bulb. Bath application of adenosine reversibly reduced the frequency of spontaneous synaptic inputs in mitral cells. DPCPX, a specific antagonist of the A₁ receptor subtype, blocked the effect of adenosine. We used paired-pulse stimulation of receptor axons and imaging of vesicle fusion in OMP-synapto-pHluorin mice to test the effect of adenosine on synapses between receptor axons and mitral cells. Adenosine neither changed the amplitude of the EPSC response nor the paired-pulse ratio as compared to control stimulations. Similarly, vesicle fusion in presynaptic structures of ORNs did not change in the presence of adenosine. In contrast, analyses of mitral-to-granule cell connections suggest an influence of adenosine on the performance of this dendro-dendritic synapse. Current clamp recordings show a direct hyperpolarising effect of adenosine and a reduction of the excitability of olfactory bulb mitral cells. These effects seem to be mediated by the activation of a potassium conductance by A₁ receptors. Morphological and physiological evidence indicate that A₁ receptors are located on mitral/tufted cells and affect other olfactory bulb neurons indirectly by decreasing the excitability of these major output neurons.

Financial support for this project is permitted by the DFG (Lo779/6).

Purinergic signaling in the olfactory epithelium

Colleen Cosgrove Hegg¹

¹Michigan State University, Pharmacology and Toxicology, 1355 Bogue St, 48824 East Lansing, USA

In the olfactory epithelium, extracellular ATP is released constitutively by vesicular secretion, hemichannels, transporters, and also following cell damage. ATP activates P2X and P2Y purinergic receptors located on multiple cell types, evoking inward currents and increases in intracellular calcium. Purinergics have multiple roles in the nasal olfactory epithelium which will be discussed. (1) Extracellular ATP modulates sensitivity of neurons to odorants at the level of the olfactory epithelium, thereby contradicting a longstanding dogma that modulation was only at the level of the olfactory bulb. (2) Extracellular ATP induces the expression of heat shock proteins via purinergic receptor activation, suggesting a role in stress signaling. (3) Extracellular ATP induces the synthesis and release of multiple growth and trophic factors, including ATP, neuropeptide Y and fibroblast growth factor 2, suggesting a role for the regulation of neurogenesis and cell survival. (4) ATP reduces apoptosis. (5) In the adult olfactory epithelium, neurogenesis normally occurs to a small extent to replace a few olfactory neurons that have died. When there is significant chemical, infectious or traumatic damage to the olfactory epithelium, the rate of neurogenesis accelerates. Extracellular ATP increases proliferation of basal progenitor cells via activation of purinergic receptors and subsequent release of growth factors. ATP also induces progenitor cell differentiation into both neurons and glial-like sustentacular cells. Constitutive release of ATP maintains a population of progenitor cells and thus has a role in tissue homeostasis. Treatment with ATP post-injury significantly potentiates cell proliferation whereas treatment with purinergic receptor antagonists significantly compromises cell proliferation. Collectively, these data suggest purinergic signaling in the olfactory epithelium has broad roles in sensory transduction, regulation of tissue homeostasis and regenerative neurogenesis following injury, and the promotion of neuronal survival.

Symposium

S24: Practically profiting from the complexity of massively parallel electrophysiological data

- S24-1** Challenges in the statistical modeling of collective dynamics in neuronal ensembles
Wilson Truccolo
- S24-2** Linking the Spatial Structures of Precise Spike Synchronization and Local Field Potentials in Motor Cortex
Michael Denker, Thomas Brochier, Alexa Riehle, Sonja Grün
- S24-3** Provenance tracking for complex data analysis workflows in neuroscience
Andrew P. Davison
- S24-4** Object or grip type representation? A comparative population study of macaque hand grasping areas AIP, F5, and M1
Stefan Schaffelhofer, Hansjörg Scherberger
- S24-5** Identification of Associated Cell Assemblies in the Interconnected Brain Regions of the Hippocampus and the Entorhinal Cortex
Jozsef Csicsvari
- S24-6** Using large scale recordings in in primate ventral visual pathway to investigate signal routing by interareal gamma-band synchronization
Iris Grothe, Simon David Neitzel, David Rotermund, Sunita Mandon, Udo Alexander Ernst, Klaus Richard Pawelzik, Andreas Kurt Kreiter
- S24-7** Neuronal correlates of visual processing and perception revealed by VSDI in behaving monkeys
Hamutal Slovin

Challenges in the statistical modeling of collective dynamics in neuronal ensembles

Wilson Truccolo¹

¹Brown University, Neuroscience, 185 Meeting St, 02912 Providence, USA

I will review several challenges in the modeling and analysis of stochastic neuronal network dynamics based on multivariate point process observations. I will discuss implementation and interpretation issues regarding the fitting of conditional intensity functions in the contexts of measured covariates and latent state-space models. In addition, I will present new applications of conditional inference to the analysis of neuronal dynamics during seizures in people with intractable epilepsy.

Linking the Spatial Structures of Precise Spike Synchronization and Local Field Potentials in Motor Cortex

Michael Denker¹, Thomas Brochier², Alexa Riehle^{2,4}, Sonja Grün^{1,3,4}

¹Institute of Neuroscience and Medicine (INM-6), Computational and Systems Neuroscience, Jülich Research Center, Jülich, Germany

²Institut de Neurosciences de la Timone (INT), UMR 7289, CNRS - Aix Marseille Univ., Marseille, France

³Theoretical Systems Neurobiology, RWTH Aachen Univ, Aachen, Germany

⁴RIKEN Brain Science Institute, Wako-Shi, Japan

In primary motor (MI) and premotor (PM) cortex, local field potential (LFP) oscillations in the beta frequency range (15–30 Hz) during an instructed delay [1] tend to display wave-like characteristics across the cortical surface [2]. On the spiking level, we observe temporally precise excess coincident spikes between simultaneously recorded neurons in direct relationship to the behavioral paradigm [3]. Excess coincidences are identified by the Unitary Event analysis method [4] which compares the distribution of empirical coincidence counts to the expectation given by the neuronal firing rates. We review our recent findings that this expression of synchronization in the conceptual framework of neuronal assemblies exhibits a tight phase relationship to the LFP oscillation that cannot be explained on the basis of the phase preference of individual neurons [5]. Moreover, we demonstrate that co-varying firing rate modulations on the time scale of beta oscillations cannot account for the preferred locking of excess spike coincidences to the LFP phase.

Here, we investigate the spatio-temporal organization of spike synchronization across cortical distances on the order of observed space constants of the beta activity, and establish its relationship to the wave-like properties of the population dynamics. Two monkeys were trained to press a switch with one hand, and then to grasp and pull an object using either a Side Grip or a Precision Grip. The force on the object could be either low or high. To allow the monkey to prepare the movement, during grip-precue sessions the grip type was revealed using a visual cue at the beginning of an instructed delay of 1 s preceding the GO signal. In contrast, the force information was encoded by the GO signal itself. For force-precue sessions, the order of grip and force cues was reversed. LFP and single unit activity were recorded from 96 electrodes in parallel using a chronically implanted Utah array (Blackrock Microsystems, Salt Lake City).

We compute spike correlations between all pairs of single units on distinct electrodes (distances 0.4–5.7 mm) using the Unitary Event analysis [4] in a time-resolved manner. Time periods of significant correlations are transformed into a dynamic graph of functional connectivity between neurons. By mapping the neurons back onto cortical space, we analyze the connectivity matrix as function of temporal, spatial, and directional parameters in relation to the behavioral task. We find that the likelihood of synchronized spiking is behaviorally modulated in time, and decreases with distance of the neurons. Finally, we link the spatial distributions of spike synchrony and LFP beta oscillations (cf. poster by Zehl et al.) and discuss our findings in relation to occurrences of higher order spike patterns (see poster by Torre et al.).

Acknowledgments: This work was partly supported by Helmholtz Alliance on Systems Biology, European Union (FP7 -ICT-2009-6, BrainScaleS), Neuro_IC2010, CNRS -PEPS, Riken -CNRS Research Agreement.

References:

1. B.E. Kilavik et al. (2012) *Cereb Cortex*, 22, 2148-59.
2. D. Rubino et al. (2006) *Nature Neurosci*, 9:1549-1557.
3. A. Riehle et al. (1997) *Science*, 278:1950-1953. B.E. Kilavik et al. (2009) *J Neurosci*, 29, 12653-12663.
4. S. Grün et al. (2002) *Neural Comput*, 14:43-80, 81-119.
5. M. Denker et al. (2011) *Cereb Cortex*, 21:2681-2695.

Provenance tracking for complex data analysis workflows in neuroscience

Andrew P. Davison¹

¹UNIC, Centre National de la Recherche Scientifique, 1 avenue de la Terrasse, 91198 Gif sur Yvette, France

Experimental protocols in neuroscience are often highly complex, the source of complexity being multi-dimensional stimuli, multi-modal and/or highly parallel recording methods, behaviour, or any combination of these.

Data analysis inherits this unavoidable complexity, and may add further complexity due to heterogeneity of data formats and software tools, multiplicity of statistical tests, and inter-disciplinary collaboration.

Given this complexity, there are many places between the original experiment and publication of the results where error can creep in, so that meticulous record keeping is essential, to be able to demonstrate precisely how, through all the intermediate steps, a given result was obtained from the original data, and to be able to reproduce the analysis six months or six years later.

Such scrupulous record keeping, or provenance tracking, is time consuming and error-prone when done by hand. A number of software tools are available to assist with provenance tracking in computational science. In this talk I will review a number of these tools, with particular emphasis on their suitability for complex analyses of highly-parallel electrophysiology data.

Object or grip type representation? A comparative population study of macaque hand grasping areas AIP, F5, and M1

Stefan Schaffelhofer¹, Hansjörg Scherberger¹

¹German Primate Center GmbH, Neurobiology, Kellnerweg 4, 37077 Göttingen, Germany

In the primate brain, the hand area of the primary motor cortex (M1), the ventral premotor cortex (area F5), and the anterior intraparietal area (AIP) are crucial for the planning and execution of hand and finger movements.

To investigate the visual and motor representation in these areas, we trained macaque monkeys to grasp 55 different objects in a delayed grasping task. The monkey first placed its hand at rest and fixated a red LED before a randomly selected object was presented for grasping (cue epoch). The animal then had to withhold movement execution until, after a short delay (planning), the fixation LED dimmed. Spiking activity was recorded on 192 channels using chronically implanted electrode arrays while arm and finger kinematics (27 degrees of freedom) were recorded with a novel instrumented glove (Schaffelhofer et Scherberger, 2012). For correlating hand kinematics with activity of the neuronal population, we extracted the mean firing rates of all recorded cells and determined the principal components of the neuronal population activity in specific task epochs. To describe the difference of the neuronal population in the 44 grasp conditions, we performed a cluster analysis and calculated the Mahalanobis distance (MD) between individual pairs of grasp conditions. Similarly, the same analysis was applied to the population of joint angles of the hand kinematics.

Expressing all MDs in a distance matrix then allowed correlating the neuronal population activity in AIP, F5, and M1 with each other as well as with the hand kinematics. Using the Pearson Correlation coefficient (r), we could determine that M1 and F5 reflect hand kinematics best during motor planning ($r=0.5$) and execution ($r=0.64$). In comparison, hierarchical clustering revealed a predominant tuning of AIP to visual object features. Furthermore, between-area correlations were consistent with a strong collaboration of AIP and F5 for visuomotor transformation and of F5 and M1 during motor execution.

These results demonstrate for the first time clearly distinct roles of AIP and F5 for the sensorimotor transformation of hand grasping action at the population level.

Identification of Associated Cell Assemblies in the Interconnected Brain Regions of the Hippocampus and the Entorhinal Cortex

Jozsef Csicsvari¹

¹Institute of Science and Technology (IST) Austria, Systems Neuroscience, Am Campus 1, 3400 Klosterneuburg, Austria

In the hippocampus new cell assemblies are formed as a result of spatial learning. The activity patterns of these cell assemblies are reactivated in sleep and this process is thought to be involved in memory consolidation. This sleep reactivation-associated memory consolidation process would involve transfer of mnemonic information from the hippocampus to its gateway structure the entorhinal cortex. We have recorded data in parallel in both of these regions to test whether reactivated hippocampal assembly patterns are transferred to the EC during sleep. The talk will show different assembly analysis-based approaches to demonstrate the transfer.

Using large scale recordings in in primate ventral visual pathway to investigate signal routing by interareal gamma-band synchronization

Iris Grothe¹, Simon David Neitzel^{1,2}, David Rotermund^{2,3}, Sunita Mandon^{1,2}, Udo Alexander Ernst^{2,3}, Klaus Richard Pawelzik^{2,3}, Andreas Kurt Kreiter^{1,2}

¹University of Bremen, Theoretical Neurobiology, Hochschulring 16a, 28359 Bremen, Germany

²University of Bremen, Bernstein Group for Computational Neuroscience, Hochschulring 18, 28359 Bremen, Germany

³University of Bremen, Institute for Theoretical Physics, Hochschulring 18, 28359 Bremen, Germany

⁴Ernst Struengmann Institute for Neuroscience in Cooperation with Max Planck Society, Fries Lab, Deutschordenstrasse 46, 60528 Frankfurt am Main, Germany

A neuron receives synaptic input from thousands of other neurons. Successful processing of a specific content requires selection of the relevant signals, while suppressing irrelevant ones. This need for signal selection is particularly evident in visual cortex. Due to convergence, neurons in downstream areas have progressively larger receptive fields (RFs) than neurons in upstream areas. Their inputs deliver a mixture of behaviorally relevant signals and a great number of signals representing behaviourally irrelevant objects. In order to dynamically route the set of relevant signals through processing pathways, a fast and flexible mechanism is needed for changing effective connectivity between neurons and subsets of their inputs. Gamma-band synchronization fulfils these requirements and has thus been proposed to underlie selective information routing.

Here, we investigate if selective attention can dynamically change the interareal gamma-band synchrony between neurons in V4 and different subsets of their inputs from V1. We used large scale recordings in two macaque monkeys and recorded neuronal activity in area V1 and V4 simultaneously. In V1 we used chronical arrays to cover a large part of the cortex and only obtained local field potentials (LFPs). In V4 we used acute electrodes, by which we obtained single-, multi-unit activity and LFPs. The monkeys had to attend to one of two continuously morphing shapes and respond to reoccurrence of the initial shape in the attended stream, while maintaining their gaze on a fixation spot. Size and position of the shapes were adjusted such that both fit into a single V4 RF while covering two separate, non-overlapping V1 RFs. In order to demonstrate a direct link between selective interareal gamma-band synchronization and signal transfer we added "tractable information" on the stimuli. Every 10ms, the brightness of the filled shapes was randomly changed, independently for each stimulus. We computed spectral coherence between stimulus brightness and the LFPs as a measure of the effective contribution (EC) of each stimulus to the neuronal activity in V4. The EC serves as a direct and unambiguous quantification of coupling in terms of linear causation.

We found strong phase-coherence of gamma-band LFP between the V4 population and the V1 subpopulation representing the behaviourally relevant stimulus. At the same time, phase-coherence between this V4 population and the V1 subpopulation representing the non-relevant stimulus was only weak. This pattern could not be explained by changes in gamma-band power in V1 or V4. As expected, strong gamma-band LFP synchronization between the V4 population and the V1 input subpopulation was accompanied by a high EC of the attended stimulus to the V4 LFP. Simultaneously, the EC of the non-attended stimulus was several times lower. A switch in attentional locus was accompanied by a reversal of the stimuli's ECs to the V4 LFP. Moreover, we found dynamical coherence patterns even on the single neuron level: also the spike field coherence of V4 neurons with the gamma-band LFP of V1 was modulated by behavioral relevance of the stimulus.

Altogether, our study shows convincingly that interareal gamma-band synchrony is directly related to the

selective routing of attended stimulus signals through the visual cortex and thus supports the hypothesis that oscillatory synchrony between areas underlies the routing of information throughout neuronal processing systems.

Neuronal correlates of visual processing and perception revealed by VSDI in behaving monkeys

Hamutal Slovin¹

¹Bar Ilan Univ., Gonda Brain Research Center, North Campus, 52900 Ramat Gan, Israel

Visual processing shows a highly distributed organization, in which the presentation of a visual stimulus simultaneously activates neurons in multiple columns across several cortical areas. It has been suggested that precise spatio-temporal activity patterns within and across cortical areas play a key role in higher cognitive, motor and visual functions. In the visual system, these patterns have been proposed to take part in binding stimulus features into a coherent object, i.e. be involved in perceptual grouping. Using voltage-sensitive-dye imaging (VSDI) in behaving monkeys, we simultaneously measured neural population activity in the primary visual cortex (V1) and extrastriate cortex (V2, V4) at high spatial and temporal resolution. We detected time-point population events (PEs) in the VSDI signal of each pixel and found they reflect transient increased neuronal activation within local populations by establishing their relation to spiking and LFP activity. Then, we searched for repeating space and time relations between the detected PEs. We demonstrate that: (i) spatio-temporal patterns occurring within (horizontal) and across (vertical) early visual areas repeat significantly above chance level; (ii) information carried in only a few patterns can be used to reliably discriminate between stimulus categories on a single-trial level; (iii) the spatio-temporal patterns yielding high classification performance are characterized by late temporal occurrence and top-down propagation, which are consistent with cortical mechanisms involving perceptual grouping.

The pattern characteristics and the robust relation between the patterns and the stimulus categories suggest that spatio-temporal activity patterns play an important role in cortical mechanisms of higher visual processing

Poster Topics

- T1 Stem cells, Neurogenesis and Gliogenesis
- T2 Axon and Dendrite Development, Synaptogenesis
- T3 Developmental Cell Death, Regeneration and Transplantation
- T4 Neurotransmitters, Retrograde messengers and Cytokines
- T5 G Protein-linked and other Receptors
- T6 Ligand-gated, Voltage-dependent Ion Channels, and Transporters
- T7 Synaptic Transmission, Pre- and Postsynaptic organization
- T8 Synaptic Plasticity, LTP, LTD
- T9 Glia, Glia-Neuron Interactions
- T10 Aging and Developmental Disorders
- T11 Alzheimer's, Parkinson's and other Neurodegenerative Diseases
- T12 Neuroimmunology, Inflammation, and Neuroprotection
- T13 Cognitive, Emotional, Behavioral State Disorders and Addiction
- T14 Vision: Invertebrates
- T15 Vision: Retina and Subcortical Pathways
- T16 Vision: Striate and Extrastriate Cortex, Eye Movement and Visuomotor Processing
- T17 Auditory Mechanoreceptors, Vestibular, Cochlea, Lateral Line and Active Sensing
- T18 Auditory System: Subcortical and Cortical Processing
- T19 Chemical Senses: Olfaction, Taste, Others
- T20 Somatosensation: Touch, Temperature, Proprioception, Nociception

T21 Motor Systems

T22 Homeostatic and Neuroendocrine Systems, Stress Response

T23 Neural Networks and Rhythm Generators

T24 Attention, Motivation, Emotion and Cognition

T25 Learning and Memory

T26 Computational Neuroscience

T27 Techniques and Demonstrations

Poster Topic

T1: Stem cells, Neurogenesis and Gliogenesis

- T1-1A** Deletion of p75 receptors induces specific effects within the hippocampal formation
Oliver von Bohlen und Halbach, Ruben Busch, Miriam Vogt, Robert Poser, Marian Baldus, Peter Gass, Martin Dokter
- T1-2A** Developmental Dynamics of Igf-signaling in cortical progenitors: Control of and through Forkhead transcription factors
Tanja Vogel, Shalaka Wahane, Riccardo Vezzali, Stefan Weise, Kathrin Thedieck, Kerstin Krieglstein
- T1-3A** Migratory behavior of dentate granule cells
Shaobo Wang, Shanting Zhao, Xuejun Chai, Jiawei Li, Mirjam Sibbe, Gary L. Westbrook, Michael Frotscher
- T1-4A** A differential proteome analysis of the olfactory bulb, cerebellum and cerebral cortex of rats indicates changes of protein expressions during development.
Michael Wille, Oliver Schmitt, Grit Lessner, Antje Schümann, Norbert Ulfig, Stefan Mikkat, Michael Kreutzer, Michael Glocker, Andreas Wree
- T1-5A** The (pro)renin receptor / ATP6ap2 is expressed in the murine hippocampus by adult and newly generated neurons and is involved in adult hippocampal neurogenesis
Simon Thomas Schäfer, Jörg Peters, Oliver von Bohlen und Halbach
- T1-6A** Direct differentiation of human iPS cells into self-renewing neural progenitors by small molecules
Raul Bukowiecki, J. Adjaye, A. Prigione
- T1-7A** Neuronal differentiation of human induced pluripotent stem cells and establishment of appropriate analysis methods
Sandra Horschitz, Friederike Matthäus, Jochen Utikal, Patrick Schloss, Andreas Meyer-Lindenberg
- T1-8A** Temporal lobe epilepsy is associated with an irreversible change of the neurogenic niche
Ute Häussler, Carola A. Haas
- T1-9A** CNTF inhibits proliferation and promotes early differentiation of progenitor cells in neural stem cell cultures from the adult subventricular zone
Sarah Frerix, B.P.S. Chakrapani, H.-D. Hofmann, M. Kirsch
- T1-1B** CNTF promotes the maintenance of neural stem cells in cultures from the adult mouse subventricular zone

- T1-2B** Altered densities and compromised migration of cortical interneurons in polysialic acid-deficient mice
Tim Kröcher, Iris Röckle, Yuchio Yanagawa, Birgit Weinhold, Hannelore Burkhardt, Herbert Hildebrandt
- T1-3B** BAF155 Controls Neurogenesis by Potentiating Pax6-dependent Transcriptional Activity
Tran Cong Tuoc, Anastassia Stoykova
- T1-4B** Sunitinib - A crosstalk of antiangiogenic and neuroprotective effects
Stefan W. Hock, Zheng Fan, Tina Sehm, Michael Buchfelder, Ilker Y. Eyüpoglu, Nic E. Savaskan
- T1-5B** Analysis of polysialic acid expression by NG2 glia in development and during remyelination after cuprizone-induced demyelination
Sebastian Werneburg, Martina Mühlenhoff, Thomas Skripuletz, Martin Stangel, Herbert Hildebrandt
- T1-6B** Analyzing Schwann Cell development along growing axons
Stephan Heermann, Markus H. Schwab, Kerstin Krieglstein
- T1-7B** Neuronal migration illuminated: a look under the hood of the living neuron
David Joseph Solecki, Niraj Trivedi, Joseph Ramahi
- T1-8B** The Role of feedback Signaling during Corticogenesis
Srinivas Parthasarathy, Anjana Nityanandam, Santos Franco, Ulrich Mueller, Victor Tarabykin
- T1-9B** Functional Analysis of STAR-Family Proteins during Oligodendrogenesis in the rodent Forebrain
Sabrina Schröder, Alexander von Holst
- T1-1C** Chondroitinsulfotransferases and their role during forebrain development
Denise Harrach, Alexander von Holst
- T1-2C** CDK5RAP2 expression during murine and human brain development correlates with cellular phenotype in MCPH3 patients
Lina Issa, Nadine Kraemer, Christian H. Rickert, Olaf Ninnemann, Gisela Stoltenburg-Didinger, Deborah Morris-Rosendahl, Angela M. Kaindl
- T1-3C** Astroglial connexins in adult neurogenesis: Gap junctional coupling is more important than adhesion.
Jiong Zhang, Peter Bedner, Stephanie Griemsmann, Radek Dobrowolski, Karen Maass, Robert Pascal Requardt, Indra Lübke-meier, Klaus Willecke, Christian Steinhäuser, Martin Theis
- T1-4C** Glial cell development in *Drosophila*: from cell fate specification to function
Benjamin Altenhein, Christian M. von Hilchen, Jan Dietrich, Alvaro E. Bustos, Andres de Visser, Tina K. Altenhein
- T1-5C** Generation of Morbus Niemann-Pick Typ C1 Patient Specific Induced Pluripotent Stem Cells

Michaela Trilck, Rayk Hübner, Arndt Rolfs, Moritz J. Frech

- T1-6C** Roles of Neurod2/6 in Cortical Plate Formation and Establishment of Pyramidal Neuron Identity
Kuo Yan, Ingo Bormuth, Markus H. Schwab, Klaus-Armin Nave, Victor Tarabykin
- T1-7C** MCPH and Effects of Cdk5rap2 Downregulation in Murine Embryonic Stem Cells
Nadine Krämer, Lina Issa, Gerda Neubert, Andrea Seiler, Olaf Ninnemann, Angela M. Kaindl
- T1-8C** Interactions between the meninges and the cortical neuroepithelium during mouse embryonic neurogenesis
Richard Sturm, Alexander von Holst
- T1-9C** New insights on Tgf β and FoxG1 crosstalk during embryonic brain development
Riccardo Vezzali, Tanja Vogel
- T1-1D** Astrocyte-assisted Neuronal Differentiation of iPS Cells Derived from Skin Biopsies of Parkinson's Disease Patients with Genetic Alterations
Lisandro Jorge Falomir Lockhart, Michelle Gralle Botelho, Luis M.A. Oliveira, Sally K. Mak, Kun-Han Lin, Holger Taschenberger, Donna J. Arndt-Jovin, Birgitt Schuele, Thomas M. Jovin
- T1-2D** Tgf β -Igf signaling interplay in murine forebrain development
Shalaka Dhanraj Wahane, Riccardo Vezzali, Stefan Weise, Mirja T Prentzell, Kathrin Thedieck, Kerstin Krieglstein, Tanja Vogel
- T1-3D** Tgfbr2 conditional knock-out in developing telencephalon reveals neurovascular defects
Nicole Hellbach, Shalaka Wahane, Tanja Vogel
- T1-4D** Neuronal bHLH proteins Neurod2/6 regulate cortical commissure formation prior to midline interactions
Ingo Bormuth, Kuo Yan, Tomoko Yonemasu, Maike Gummert, Mingyue Zhang, Sven Wichert, Olga Grishina, Alexander Pieper, Weiqi Zhang, Sandra Goebbels, Victor Tarabykin, Klaus-Armin Nave, Markus Schwab
- T1-5D** Developmental changes in the composition of the olfactory bulb layers in the American Mink (*Neovison vison var. atratus*)
Elke Weiler, Willi Bennegger
- T1-6D** Role of histone modifications during cerebral cortex development
Deborah Roidl, Stefanie Heidrich, Jan Pruszk, Tanja Vogel
- T1-7D** STAR Family Proteins: Cortical Expression Pattern and Function in Mouse Cortical Neural Stem/Progenitor Cells
Alexander von Holst, Bettina Bertam
- T1-8D** Determination of the Tgfbr mediated proteome in the context of neurovascular development of the forebrain
Stefan Weise, Peer-Hendrik Kuhn, Nicole Hellbach, Stefan F. Lichtenthaler, Kathrin Thedieck, Tanja Vogel

Deletion of p75 receptors induces specific effects within the hippocampal formation

Oliver von Bohlen und Halbach, Ruben Busch¹, Miriam Vogt², Robert Poser¹, Marian Baldus¹, Peter Gass², Martin Dokter¹

¹Ernst Moritz Arndt Universität Greifswald, Institut für Anatomie und Zellbiologie, Friedrich Loeffler Str. 23c, 17487 Greifswald, Germany

²Zentralinstitut für seelische Gesundheit (ZI), J5, 68159 Mannheim, Germany

In vivo the p75 receptor is expressed in two splice variants, a full-length version and a truncated isoform, which lacks the neurotrophin binding site. Two knockout mice are available: in p75ExIII knockouts the full-length receptor is deleted, whereas in p75ExIV knockout both, the full-length and the truncated isoform are not expressed. These two knockout lines provide the opportunity to distinguish the possible roles of these two p75 receptors. The p75 binds all neurotrophins with low affinity. Depending on co-signaling with the high affinity trk-receptor and the availability of neurotrophins, p75 can signal survival and differentiation but also cell death. Since the p75 is highly expressed in the dentate gyrus (DG) and since the DG is a structure capable of spinogenesis and adult neurogenesis, we tried to identify possible roles of the p75 in these processes.

Using different markers for specific stages of adult neurogenesis, we could e.g. demonstrate an increase in the number of differentiated doublecortin-positive cells in the granule layer of the DG in p75 knockout mice. Measurement of spine densities in Golgi-stained sections revealed an increase in spine densities in the DG by comparing knockout and wildtype mice. Concerning possible roles of the p75 in apoptosis, we used active-caspase3 as antigen and could demonstrate a decreased number of active-caspase3-cells in the DG of knockout mice. Since the hippocampus is highly innervated by the cholinergic system, originating from e.g. the medial septal nuclei and since it is still a matter of debate whether there is a substantial loss of cholinergic fibers in the hippocampus during aging, we evaluated the involvement of p75 on the density of the cholinergic fibers in the hippocampus. To analyse the cholinergic fiber density (CFD) within the hippocampus we used adult and aged p75 deficient mice and their controls. The comparison of adult and aged wildtype mice revealed no significant age-related decrease in the CFD. On the contrary, our data indicate that both knockout lines showed increased CFD which, in case of p75ExIV, persisted with aging. To investigate whether p75 deficiency has an impact upon behavior, we designed a series of behavioral tests, including Open Field, Dark/Light Box, T-Maze, Holeboard, Morris Water Maze and Fear Conditioning. We only analyzed p75ExIII mice, since p75ExIV had to be precluded due to severe ataxia, which is familiar with this line. The p75ExIII knockout mice showed increased locomotor activity, altered exploratory behavior and decreased anxiety in the Open Field and the Dark/Light Box. Performance in the Water Maze was impaired in the probe trial. Thus, we could show that deficiency of p75 affects some, but not all, hippocampus dependent behavioral tasks and induces specific morphological alterations in the hippocampus. Moreover, we were able to demonstrate that p75ExIV knockout mice show specific alterations in adult neurogenesis that were not seen in p75ExIII knockout mice.

Supported by the DFG (BO 1971/5-1).

Developmental Dynamics of Igf-signaling in cortical progenitors: Control of and through Forkhead transcription factors

Tanja Vogel, Shalaka Wahane¹, Riccardo Vezzali¹, Stefan Weise¹, Kathrin Thedieck^{2,3,4}, Kerstin Krieglstein¹

¹Albert-Ludwigs-University Freiburg, Anatomy and Cell Biology, Molecular Embryology, Albertstr. 17, 79104 Freiburg/Breisgau, Germany

²Albert-Ludwigs-University Freiburg, Institute for Biology III, Bioinformatics and Mol. Genetics

³Albert-Ludwigs University Freiburg, BIOS Centre for Biological Signalling Studies Freiburg

⁴Albert-Ludwigs University Freiburg, Center for Systems Biology (ZBSA)

Insulin as well as Insulin-like growth factors 1 and 2 (Igf1, Igf2) are expressed during brain development. It has been recognised that early brain development is accompanied by higher Igf1 levels compared to Igf2. Later time points show opposing gradients, implicating that Igf2 has prominent roles in the adult while development is dominated by Igf1. However, precise data on establishment and function of this dynamic expression during mouse brain development is lacking. We show that Igf1 and 2 have distinct gradients of expression levels in developing cortical cells, that result in time-dependent differential activation of downstream signalling pathways. Using cortical cells of different developmental time points and isolated from different mouse mutants with defective Tgf β -signalling pathway or FoxG1-transcription factor, we elaborate a novel regulatory mechanism that establishes Forkhead transcription factors not only as downstream targets of PI3-Akt-signalling but also as regulators of Igf ligand expression and potential Igf bioavailability. Our results shed new light upon the Smad/FoxO/FoxG1-dependent transcription that has been elucidated in keratinocytes but which was so far not investigated in primary cells that express these transcriptional regulators under physiological conditions. In this context we did not confirm p21/Cdkn1a as primary target for Smad-dependent transcription.

Migratory behavior of dentate granule cells

Shaobo Wang, Shanting Zhao¹, Xuejun Chai¹, Jiawei Li¹, Mirjam Sibbe³, Gary L. Westbrook⁴, Michael Frotscher¹

¹Institute for Structural Neurobiology, Center for Molecular Neurobiology Hamburg (ZMNH), Falkenried 94 , 20251 Hamburg, Germany

²Faculty of Biology, University of Freiburg, 79104 Freiburg, Germany

³Institute of Anatomy and Cell Biology, University of Freiburg, 79104 Freiburg, Germany

⁴Vollum Institute, Oregon Health and Science University, Portland, Oregon 97239, USA

Neuronal migration is an important step in brain development. Reelin, an extracellular matrix protein, is required for proper neuronal migration. Previous research mainly focused on the migration of neurons in the neocortex and little is known about the migratory behavior of granule cells in the dentate gyrus.

Newly generated granule cells have to migrate to find their positions in the network of the dentate gyrus. In the present study, POMC-EGFP mice were used to identify newly generated dentate granule cells in slice cultures of hippocampus and to monitor their migratory behavior using real-time microscopy. We studied the migratory behavior of dentate granule cells in wild-type mice and reeler mutants deficient in Reelin, focusing on potential differences between genotypes in cell morphology, cell motility, migration direction and migration velocity. Newly generated granule cells of the dentate gyrus showed typical morphological features of migrating neurons with a long radially oriented leading process and a short trailing process, reminiscent of migrating neurons in the neocortex. The migration direction was towards the granule cell layer. During their migratory period, the motility of newly generated granule cells in reeler was clearly reduced when compared with wild-type granule cells and the cells did not show a preferred orientation of their migratory route.

Our results indicate that the migratory behavior of newly generated dentate granule cells in reeler mutants differs from that in wild-type mice, resulting in abnormal positioning and a scattered distribution all over the dentate gyrus. Moreover, our results provide evidence for Reelin playing a key role in the directed migration of granule cells in the dentate gyrus.

(Supported by the DFG: FR 620-12/1)

A differential proteome analysis of the olfactory bulb, cerebellum and cerebral cortex of rats indicates changes of protein expressions during development.

Michael Wille, Oliver Schmitt¹, Grit Lessner¹, Antje Schümann¹, Norbert Ulfig¹, Stefan Mikkat², Michael Kreutzer², Michael Glocker², Andreas Wree¹

¹University of Rostock, Department of Anatomy, Gertrudenstraße 9, 18055 Rostock, Germany

²Proteome Center Rostock, Schillingallee 69, 18055 Rostock, Germany

Many neurological disorders are caused by changes in the expression of proteins during brain development. Though, these variations in the developing proteome are not fully understood. In this study, Wistar rats were used for the standardized experiments. To analyze the different expression of proteins during development, three brain regions (olfactory bulb, cerebellum and cerebral cortex) were removed at three postnatal time points (7 days (P7), 90 days (P90) and 637 days (P637)). The total homogenates of brain regions (protein concentration 575 µg / ml) were separated by two-dimensional gel electrophoresis (2-DE) followed by a differential spot analysis. Proteins in spots with a differential expression were identified by MALDI-TOF-MS.

Most differential expressions of proteins of these regions were found in the period during P7 and P90 whereas changes in protein expression also could be observed at P637. Furthermore, differences in regulation and the total amount of expressed proteins between the three regions were detected.

Especially proteins for carbohydrate metabolism, protein biosynthesis, regulatory proteins and structural proteins were expressed differentially during development.

It could be shown that proteins which are important for synaptic plasticity and activity like *synapsin-2*, a protein involved in vesicular transport of specific neurotransmitters is absent in P7. Also other proteins with axonal locations turn out to be developmentally regulated. The protein *tubulin beta 2A* is absent in P7 and *tubulin folding cofactor B* in P90. They are localized in growth cones of outgrowing axons during neurogenesis where they are required for microtubule dynamics and plasticity. Moreover, a differential regulation of *sumo activating enzyme subunit 1* could be shown at early stages, which indicates an increased sumoylation which also plays a role during neuronal development and function.

Additionally, it could be demonstrated that proteins of other categories, e.g. chaperones, proteins involved in antioxidative mechanisms, transport proteins and degrading proteins display differences in their expression.

In conclusion, age related changes of proteins with axonal and synaptic locations or functions were found in P7, P90 and P637. These findings may indicate long-term development processes and/or neuronal plasticity that are still ongoing even in adult rats.

The (pro)renin receptor / ATP6ap2 is expressed in the murine hippocampus by adult and newly generated neurons and is involved in adult hippocampal neurogenesis

Simon Thomas Schäfer, Jörg Peters¹, Oliver von Bohlen und Halbach²

¹Institut für Physiologie, Greifswalder Str. 11 c, 17495 Karlsburg, Germany

²Institut für Anatomie und Zellbiologie, Friedrich-Löffler-Str. 23c, 17489 Greifswald, Germany

The (pro)renin receptor ((P)RR) is a single transmembrane domain receptor that has been shown to be involved in developmental processes. Recent data from *Drosophila* and *Xenopus* revealed essential functions in cellular physiology and signaling during fetal brain development.

In 2010, Cruciat and colleagues demonstrated that the (P)RR is capable of binding V-ATPase subunits and is required for V-ATPase mediated acidification of Wnt signaling in embryonic development. Adult neurogenesis shares many similarities with fetal and embryonic neuronal development, but is restricted to some brain areas, including the hippocampus. We investigated the expression of the (P)RR within the adult hippocampal formation and during different stages of adult neurogenesis within the dentate gyrus (DG). Furthermore we developed a mouse model possessing a DG-specific knockdown of the (P)RR protein using RNAi-based lentiviral (LV) approaches to perform functional analysis of adult neurogenesis.

To examine the expression of the (P)RR/ATP6ap2 during different stages of adult neurogenesis, we used appropriate markers, including SRY-related HMG-box gene 2 (Sox2), phosphohistone H3 (pH3), doublecortin (DCX) and neuron-specific nuclear protein (NeuN). Digital-image analysis-assisted manual counts of one-in-12 series of sections were made using ImageJ (NIH, USA). For co-localizing experiments, a LSM confocal imaging system (Leica TCS SP5) was used. For loss-of-function studies 1 μ l of vector concentrate (LV-(P)RR-shRNA vs. LV-NTC-GFP) was stereotactically injected into the right hippocampal DG of adult male C57Bl/6J mice. Areas infected by LVs were identified by the expression of GFP four weeks after infection. For *in vivo* neurogenesis experiments we counted DCX- and pH3-positive cells in a one-in-six series of 30 μ m thick sections throughout the rostrocaudal extend of the infected granule cell layer.

We could demonstrate that the receptor is predominantly expressed by neuronal cells in all subregions of the hippocampus, including the DG. The (P)RR was not expressed by stem cells or progenitor cells, as indicated by the absence of colocalisation with Sox2. However, (P)RR protein was detected in DCX-positive cells located both in the subgranular zone (SGZ) and in the granular layer of the DG, indicating that (P)RR is expressed by cells belonging to the neuronal lineage. The majority of neurons expressing (P)RR protein were NeuN-positive, indicating that (P)RR is mainly expressed by adult granule cells within the DG.

Referring to our mouse model, we could demonstrate that the injected lentiviruses exhibited the presumed cell tropism within the hippocampus. Both, Sox2-positive cells in the SGZ probably belonging to the pool of progenitor cells as well as proliferating pH3-positive cells were infected, indicated by the expression of the GFP reporter. Current results indicate that mice injected with LV-(P)RR-shRNA reveal a marked reduction in the number of DCX-positive neuroblasts per mm² infected area as compared to those injected with the control vector LV-NTC-GFP (non-target-control), whereas the number of pH3-positive cells remained unaffected. Together, these data suggest that the (P)RR may play a role in late stages of adult hippocampal neurogenesis.

Direct differentiation of human iPS cells into self-renewing neural progenitors by small molecules

Raul Bukowiecki, J. Adjaye^{2,3}, A. Prigione^{1,3}

¹Max Delbrueck Center for Molecular Medicine, Berlin

²Heinrich-Heine-Universität, Düsseldorf

³Max Planck Institute for Molecular Genetics, Berlin

Here, we report a rapid and feasible method to derive self-renewing neural progenitor cells (NPCs) from human pluripotent stem cells. The approach adapted from Li et al.(1) gives comparable results using human embryonic stem cells (ESCs) and human induced pluripotent stem (iPS) cells generated from fibroblasts (2). The protocol exhibits major advantages in comparison to standard approaches. First, it does not require the formation of embryoid bodies (EBs). Second, it is operator-independent, as it bypasses the need for tedious manually isolating neural rosettes.

The combination of, human leukaemia inhibitory factor (hLIF), a GSK3 β inhibitor (CHIR), and a TGF β inhibitor (SB) in chemically defined media is sufficient to induce the conversion of iPS cells to highly proliferating NESTIN-positive NPCs (98 %).

Inhibition of basic fibroblast growth factor (FGF) has been found important in driving neuronal conversion (3). Interestingly, FGF withdrawal coupled with the small molecule cocktail appears capable to efficiently derive NPCs. Importantly, the obtained NPC population shows distinct morphological changes within a very short time (7-10 days). NPCs could be cultured over several passages without loss of proliferation (split 1:10) as well as differentiated into TUJ1-positive neurons.

Overall, NPCs represent an inexhaustible source of neurogenic tissue exhibiting developmental potential for multiple neuronal subtypes after treatment with morphogens like retinoic acid (RA), sonic hedgehog (SHH), or FGF8. Further, the application of small molecules guarantees high reproducibility and genomic stability. Thus, after non-viral generation of iPS cells from patients, small molecule-based derivation of NPCs displays an advantageous approach to generate neurons with positional effect-free phenotypes for disease modelling.

(1) Li *et al.*(2011), PNAS, Vol. 108, 8299–8304

(2) Prigione *et al.*(2011), Stem Cells, Vol. 29, 1338–1348

(3) Greber *et al.*(2011), EMBO Journal, Vol. 30, 4874–4884

Neuronal differentiation of human induced pluripotent stem cells and establishment of appropriate analysis methods

Sandra Horschitz, Friederike Matthäus¹, Jochen Utikal², Patrick Schloss¹, Andreas Meyer-Lindenberg¹

¹Central Institute of Mental Health, Department of Psychiatry, Medical Faculty Mannheim/Heidelberg University, Mannheim, Germany

²Skin Cancer Unit, German Cancer Research Center (DKFZ), Heidelberg, Germany, and Department of Dermatology, Venereology and Allergology, University Medical Center Mannheim, Medical Faculty Mannheim/Heidelberg University, Mannheim, Germany

Induced pluripotent stem cells (iPSCs) can be generated from several differentiated mouse and human cell types through ectopic expression of transcription factors such as Oct4, Sox2, Klf4 and c-Myc. iPSCs have the features of embryonic stem cells including immortal growth and pluripotency, measured by their ability to differentiate into multiple cell types in teratomas and their contribution to germline-competent chimeras in mice. Patient-derived iPSCs provide an ideal source for studying complex diseases in vitro and potentially for treating disorders in the clinic in future.

In addition, human iPSCs give the possibility to establish human cell based models with a defined genetic background, especially for cellular systems that are not accessible in vivo as for example neuronal cells. Compared to the systems that have been used so far to analyze neuronal processes, i.e. lymphocytes, post-mortem studies, or animal models, human iPSC-derived neurons have the advantage that the molecular and cellular states closely reflect the human condition.

Here, human iPSCs that have been generated from skin biopsies were differentiated with a standardized protocol into functional glutamatergic neurons. This protocol is based upon the embryonic development of ectodermal cells into mature forebrain neurons with the addition of defined pathway agonists and antagonists. The protein expression of several marker proteins was analyzed in the developing neurons qualitatively and quantitatively. Neuronal growth was measured during differentiation and synapses were quantified in terminally differentiated neurons.

Temporal lobe epilepsy is associated with an irreversible change of the neurogenic niche

Ute Häussler, Carola A. Haas¹

¹Experimental Epilepsy Research, Dept. of Neurosurgery, Faculty of Medicine, Breisacherstrasse 64, 79106 Freiburg, Germany

Temporal lobe epilepsy (TLE) is characterized by increased structural plasticity in the dentate gyrus, including granule cell dispersion (GCD), mossy fiber sprouting and altered neurogenesis in the subgranular zone (SGZ). Using the intrahippocampal kainate (KA) model for TLE we have shown that in the septal hippocampus (close to the injection site) neurogenesis was completely lost and a large number of proliferating cells in the hilus took a glial fate (Häussler et al., 2012, Cerebral Cortex). Remarkably, the areas with lost neurogenesis overlapped with the septotemporal extent of GCD. In contrast starting from a transition zone in the intermediate hippocampus where granule cell layer width was back to normal, cell proliferation was significantly increased in the SGZ and resulted in increased neurogenesis in the intermediate and temporal ipsilateral and the entire contralateral hippocampus. Intrahippocampal recordings revealed that this region-dependent regulation of neurogenesis was due to differential strength of status epilepticus at the respective sites.

In our current study, we asked (a) whether cell proliferation in the SGZ is still increased at 3 weeks after KA injection when GCD and recurrent seizures have fully developed; (b) whether neurogenesis in the septal hippocampus can be reactivated with a strong proliferative stimulus and (c) whether the strong neurogenesis in the temporal hippocampus is exhaustive or can be further stimulated.

To this end, we performed a single unilateral intrahippocampal kainate injection (KA_{hipp}) in adult mice and three weeks later induced a second status epilepticus with a systemic (intraperitoneal) kainate injection (KA_{sys}), which was quantified according to Racine's scale. Controls received a saline injection (SA_{sys}). Another group received only a KA_{sys} injection. Mice were injected with bromodeoxyuridine (BrdU) 6 days after the KA_{sys} injection and perfused the next day. We performed immunocytochemistry for BrdU and doublecortin (DCX) and quantified BrdU -positive cells in the septal, intermediate and temporal hippocampus.

We show that cell proliferation in the KA_{hipp}+SA_{sys} group was comparable to (contralateral hippocampus) or below (ipsilateral hippocampus) control levels in untreated animals indicating that the increase in proliferation and neurogenesis shortly after KA_{hipp} was only transient. Yet, when adding the systemic KA injection, the KA_{hipp}+KA_{sys} group reached Racine stage 4/5 in shorter time than the KA_{sys} only group, indicating a higher sensitivity of the already epileptic network. While in the KA_{sys} group cell proliferation in the SGZ and neurogenesis was strongly increased at all septotemporal sites, comparable to previous results (Lugert et al., 2010, Cell Stem Cell), the KA_{hipp}+KA_{sys} group showed a completely different pattern. Cell proliferation in this group was comparable to the KA_{hipp}+SA_{sys} control group indicating that the second strong stimulus was not able to reactivate proliferation. Furthermore, neurogenesis in the ipsilateral areas with GCD could not be recovered and there was no further increase in neurogenesis in the temporal and contralateral hippocampus. Our results thus show that the neurogenic niche is irreversibly changed at 3 weeks after the intrahippocampal KA injection in the whole hippocampus.

This work was supported DFG SFB TR3 and SFB780.

CNTF inhibits proliferation and promotes early differentiation of progenitor cells in neural stem cell cultures from the adult subventricular zone

Sarah Frerix, B.P.S. Chakrapani¹, H.-D. Hofmann¹, M. Kirsch¹

¹Albert-Ludwigs-University, Institute of Anatomy & Cell Biology, Dept. of Neuroanatomy, Group of Hofmann/Kirsch, Albertstr. 23, 79104 Freiburg, Germany

Ciliary neurotrophic factor (CNTF) has been shown to be involved in the regulation of adult neurogenesis both in the dentate gyrus subgranular zone and in the subventricular zone. Previous studies suggested that the cytokine is required for the maintenance of neural stem cells (NSC) but may also influence the production of rapidly proliferating progenitor cells. We have used neurosphere cultures from the subventricular zone of adult mice to study the effects of CNTF on progenitor cell proliferation and differentiation. Neurospheres formed by adult NSC/progenitors reflect the neurogenic lineage in that they contain cells with stem cell properties and different types of proliferatively active progenitor cells.

Proliferation (cell number and neurosphere size) was massively (> 50%) reduced when CNTF was added to the culture medium that routinely contained EGF and bFGF as mitogens. Addition of CNTF resulted in a rapid reduction of BrdU-incorporating and Ki67-positive cells by 80% and 65%, respectively. In parallel, the expression of the cdk inhibitor p21 increased more than 4-fold indicating that the cytokine induced cell cycle exit in the majority of proliferating cells. This conclusion was supported by the observation that CNTF treatment resulted in a massive increase in the number cells expressing markers for astrocytes (GFAP; 45% of all cells) and immature neurons (Tuj-1; 40% of all cells). Many of these cells were double-labelled for both markers suggesting that they may represent a neuro-glial progenitor state. More differentiated neurons, e.g. DCX-positive cells, were very rare.

The effects of CNTF were reversible. After removal of CNTF the cultures regained normal proliferative activity and the number of BrdU-incorporating and Ki67-positive cells increased reaching levels of control cultures. Moreover, the expression of the differentiation markers decreased. This indicates that CNTF, despite the presence of the mitogens, can drive the neural progenitor cells to enter a reversible, postmitotic state of neural precursor cells but does not induce their terminal differentiation.

We further examined whether NSC cultures pre-treated with CNTF exhibit enhanced neuronal differentiation when subsequently switched to differentiation-promoting culture conditions (absence of EGF and bFGF). The results indicate that pretreatment with CNTF does not by itself direct the subsequent differentiation into neurons and glia but that this step requires the action of additional signals.

We conclude that CNTF negatively influences the amplification of rapidly proliferating SVZ progenitor cells by inducing their exit from the cell cycle and their reversible differentiation into neuron-glial precursors. As we can also show that CNTF stimulates the maintenance or self-renewal of a cell population with stem cell-like properties in the same cultures (see accompanying poster), the same signalling molecule seems to have distinct effects in different stages of the adult neurogenic lineage.

Supported by the Deutsche Forschungsgemeinschaft, Ki419/5-1.

CNTF promotes the maintenance of neural stem cells in cultures from the adult mouse subventricular zone

Judith M. Flurer, B.P.S. Chakrapani¹, H.-D. Hofmann¹, M. Kirsch¹

¹Albert-Ludwigs-University, Institute of Anatomy & Cell Biology, Dept. of Neuroanatomy, Group of Hofmann/Kirsch, Albertstr. 23, 79104 Freiburg, Germany

Ciliary neurotrophic factor (CNTF) has been shown to be involved in the regulation of adult neurogenesis both in the dentate gyrus subgranular zone and in the subventricular zone. Results from previous studies have indicated that CNTF or related cytokines may be important at various stages of embryonic and adult neurogenesis and gliogenesis. Here we studied the effects of CNTF on cell populations with neural stem cell properties in neurosphere cultures prepared from the SVZ of adult mice.

Addition of CNTF to neurosphere cultures routinely grown in the presence of the mitogens EGF and bFGF inhibited neurosphere growth and reduced the fraction of proliferatively active cells within 2 days from about 60% to less than 10% as determined by immunolabeling for Ki67 and by measuring BrdU incorporation. The decrease in proliferation was due to cell cycle exit induced by CNTF, most likely in rapidly proliferating progenitor cells (see accompanying poster). When CNTF-treated neurospheres were dissociated and reseeded, the cells showed an enhanced capacity to form secondary spheres indicating that CNTF increased the number of sphere-forming cells with stem cell-like properties.

To characterize the cell type(s) promoted by CNTF, we further analyzed changes in growth properties and cellular composition of the neurospheres in response to CNTF. Cells proliferating in the presence of the cytokine showed a reduced proliferation rate due to increased cell cycle duration. CNTF treatment resulted in a 5-fold increase in the percentage of cells expressing CD15/SSEA-1, a marker for stem cells and multipotent progenitors from 2.5% in controls to 12% and to more than 20%, when neurospheres were grown with CNTF for several passages. Similarly, the number of cells isolated by FACS as the so called side population that has been described to represent the stem cell population, was also 5-fold higher in the presence of CNTF (1.65% versus 0.35% in controls). These results indicate that CNTF promotes the maintenance and/or self-renewal of cells from the adult SVZ that exhibit characteristics of neural stem cells.

By pharmacological experiments and by studying neurosphere cultures derived from mouse mutants with deficiencies in cytokine receptor associated signalling pathways, we could demonstrate that all the in vitro effects of CNTF observed on stem cells and progenitors were dependent on the JAK-STAT3 pathway. The in vivo relevance of the results is presently examined in adult mice by electroporation of DNA constructs coding for dominant negative and constitutively active STAT3.

Supported by the Deutsche Forschungsgemeinschaft, Ki419/5-1.

Altered densities and compromised migration of cortical interneurons in polysialic acid-deficient mice

Tim Kröcher, Iris Röckle¹, Yuchio Yanagawa³, Birgit Weinhold¹, Hannelore Burkhardt¹,
Herbert Hildebrandt^{1,2}

¹Hannover Medical School, Cellular Chemistry, Carl-Neuberg-Str. 1, 30625 Hannover, Germany

²Center for Systems Neuroscience (ZSN) Hannover

³Gunma University, Japan

The neural cell adhesion molecule NCAM and its posttranslational modification with polysialic acid (polySia) are major determinants of cellular interactions during brain development and dysregulation of this system has been linked to schizophrenia. Polysialylation of NCAM is implemented by the two polysialyltransferases ST8SialII and ST8SialIV. Genetic ablation of these enzymes generates polySia-negative but NCAM-positive mice that are characterized by severe defects of major brain fiber tracts. In addition, polySia deficiency impairs migration of subventricular zone-derived interneuron precursors towards the olfactory bulb and of undefined progenitors during neocortex development. In the current study, we analyzed how loss of polySia affects selected interneuron populations in the prefrontal cortex, a brain region relevant to the pathophysiology of schizophrenia. Densities of cells immunopositive for major interneuron markers were analyzed comparatively in the forebrain of polySia-deficient mice at the age of 4 weeks and 3 months. Pronounced alterations of different GABAergic interneuron subtypes were detected in mouse lines with different degrees of polySia-deficiency. These findings may be explained by a compromised tangential migration of cortical interneuron precursors during development. Using live imaging of embryonic brain slice cultures, decreased velocities of interneuron precursors were observed after enzymatic removal of polySia in vitro. Thus, cortical interneuron migration depends on the presence of polySia and attenuation of polySia synthesis causes changes in defined interneuron subtypes, which are reminiscent to neuropathological findings in schizophrenia.

BAF155 Controls Neurogenesis by Potentiating Pax6-dependent Transcriptional Activity

Tran Cong Tuoc, Anastassia Stoykova^{1,2}

¹Max-Planck-Institute for biophysical Chemistry, Molecular Developmental Neurobiology, Am Fassberg 11, 37077 Göttingen, Germany

²Cluster of Excellence "Nanoscale Microscopy and Molecular Physiology of the Brain" (CNMPB)- Göttingen²

Chromatin remodeling factors play essential role in neurogenesis. However, elucidation of the link between chromatin changes and specific transcriptional program that control neurogenesis remains a challenge. Here, we identify a genetic interaction between BAF155 subunit of the chromatin remodeling BAF complex and transcription factor Pax6, a key regulator in neurogenesis of lens, olfactory epithelium and neocortex. We found that mice with conditional deletion of BAF155 have similar phenotypes to those of Pax6 -deficient mutants, including dysgenesis of eye and olfactory structures, and impaired neurogenesis in these structures as well as in developing cortex. The developmental defects of BAF155cKO mice were dramatically enhanced by additional heterozygous loss of one Pax6 allele. Moreover, we show that BAF155 is required for normal activation of Pax6-dependent transcriptional activity in stem/progenitor cells of olfactory neuroepithelium and cortex. Our findings reveal a novel molecular mechanism mediated by transcription factor Pax6 in epigenetic control of mammalian neurogenesis via chromatin remodeling mSWI/SNF complex.

Sunitinib - A crosstalk of antiangiogenic and neuroprotective effects

Stefan W. Hock, Zheng Fan¹, Tina Sehm¹, Michael Buchfelder¹, Ilker Y. Eyüpoglu¹, Nic E. Savaskan¹

¹Neurooncology Laboratory, Department of Neurosurgery, University Medical School Erlangen-Nuremberg, Schwabachanlage 6, D-91054 Erlangen, Germany

Sunitinib is a potent pan receptor tyrosine kinase inhibitor (RTKs) known to suppress cell signaling. Among the RTKs are the vascular endothelial growth factor receptors (VEGFRs) and the platelet-derived growth factor receptors (PDGFRs) which both play a pivotal role in the process of neovascular formation and tumor cell proliferation. In the organotypic glioma-induced invasion model (OGIM), which we established previously, we could show that under Sunitinib treatment (10, 50, 100 μ M) the vessel density is normalized in comparison to the control group. We were staggered with our second discovery: When treated with Sunitinib the cell death in the organotypic brain slices was diminished. In further proceeding, we were able to show that Sunitinib has indeed a neuroprotective effect. The tumor itself creates a microenvironment which damages the surrounding tissue and allows the tumor cells to proliferate and migrate. We imitated the toxic tumor microenvironment with high dosages of glutamate, mimicking the cellular stress normally caused by the tumor. Under Sunitinib-treatment cell death in neuronal and astrocytal cells was significantly lower. In contrast, cell death in tumoral cell culture (U87, U251, GL261, F98) was significantly higher, with lower proliferation rates. Sunitinib has therefore beside the know anti-angiogenic and anti-proliferative effects a newly discovered neuroprotective component.

Analysis of polysialic acid expression by NG2 glia in development and during remyelination after cuprizone-induced demyelination

Sebastian Werneburg, Martina Mühlenhoff¹, Thomas Skripuletz², Martin Stangel^{2,3},
Herbert Hildebrandt^{1,3}

¹Hannover Medical School, Institute for Cellular Chemistry, Carl-Neuberg-Straße 1, 30625 Hannover, Germany

²Hannover Medical School, Department of Neurology, Carl-Neuberg-Straße 1, 30625 Hannover, Germany

³Center for Systems Neuroscience (ZSN), Hannover, Germany

Polysialic acid (polySia) is regarded as a negative regulator of remyelination (Franklin, French-Constant 2008, *Nature Rev Neurosci* 9:839). Due to its well-described anti-adhesive properties the presence of polySia may prevent attachment of myelinating oligodendrocytes, to axons (Charles et al. 2000, *Proc Natl Acad Sci* 97:7585). As shown in mice lacking one of the two polySia-synthesizing enzymes ST8SialI and ST8SialIV, a partial loss of polySia accelerates remyelination after cuprizone-induced demyelination (Koutsoudaki et al. 2010, *Neuroscience* 171:235). This effect has been assigned mainly to enhanced differentiation of NG2 (neuron-gial antigen 2) -positive oligodendrocyte precursor cells (OPCs). Underlying mechanisms, however, are yet unresolved and the differential contribution of the two polysialyltransferases as well as the cells and protein substrates involved in presenting polySia in the context of remyelination are elusive. During the development of the mammalian brain the neural cell adhesion molecule NCAM is the primary target for posttranslational modification with polySia, but recently, the synaptic cell adhesion molecule SynCAM1 has been described as a novel, alternative polySia carrier. Strikingly, polySia-SynCAM1 was exclusively found on a subpopulation of NG2-expressing glia in the perinatal mouse brain (Galuska et al. 2009, *PNAS* 107:10250). These multifunctional precursor cells serve as the primary source of myelinating oligodendrocytes in development and during myelin repair after cuprizone-induced demyelination. Therefore, we studied the induction of polySia-SynCAM1 expression in the cuprizone animal model. To characterize the polySia-SynCAM1-positive subpopulation of NG2 cells and to elucidate their developmental potential, current work focuses on enrichment and immunocytological analysis of polySia-positive NG2 cells.

Analyzing Schwann Cell development along growing axons

Stephan Heermann, Markus H. Schwab², Kerstin Krieglstein^{1,3}

¹Institute of Anatomy and Cell Biology, University of Freiburg, Freiburg, Germany, Department of Molecular Embryology, Albertstrasse 17, 79104 Freiburg, Germany

²Max Planck Institute of Experimental Medicine, Department of Neurogenetics, Göttingen, Germany

³ FRIAS, University of Freiburg

Analysis of Schwann cell (SC) development has been hampered by lack of growing axons in many commonly used in vitro assays. As a consequence, molecular signals and cellular dynamics of SC development along peripheral axons are still only poorly understood. Here we use a superior cervical ganglion (SCG) explant SC development assay, in which the development of endogenous SC can be investigated along growing axons. With this assay we identified Nrg1 type III ErbB signaling to be important for SC development in the sympathetic nervous system. Interference with the ErbB receptor lead to reduced SC proliferation, increased SC apoptosis and to reduced SC colonization of distal axonal segments. However, our data suggest that the effect of ErbB signaling on SC colonization of distal axonal segments is mediated mainly via supporting SC survival in proximal axonal regions rather than by directly altering SC motility.

Notably GDNF, also suggested to be involved in SC migration, seems to be dispensable for embryonic SC migration in the murine sympathetic nervous system and also along the sciatic nerve.

Neuronal migration illuminated: a look under the hood of the living neuron

David Joseph Solecki, Niraj Trivedi¹, Joseph Ramahi¹

¹St. Jude Children's Research Hospital, Developmental Neurobiology, 262 Danny Thomas Place, 38105 Memphis, USA

During vertebrate brain development, migration of neurons from the germinal zones to their final laminar positions is essential to establish functional neural circuits. Whereas key insights into neuronal migration initially came from landmark studies identifying the genes mutated in human cortical malformations, cell biology and state of the art time lapse microscopy has recently expanded our understanding of how cytoskeletal proteins and molecular motors drive the morphogenic cell movements that build the developing brain. The work from a variety of laboratories suggests the neurons migrate with a two-stroke cadence where the centrosome or cytoplasmic organelles move toward the direction of migration before somal translocation that ultimately has served as an excellent model to explore cytoskeletal function in migrating neurons throughout the CNS. Recently, we have identified the proximal portion of the cerebellar granule neuron leading process a region possessing high acto-myosin contractility necessary for centrosomal and somal translocation during nucleokinesis. I will present the latest results from my laboratory further examining leading process acto-myosin and highlight its role in positioning the golgi complex, primary cilia and regulating leading process adhesion during nucleokinesis.

The Role of feedback Signaling during Corticogenesis

Srinivas Parthasarathy, Anjana Nityanandam², Santos Franco³, Ulrich Mueller³, Victor Tarabykin¹

¹Institute of Cell Biology and Neurobiology, NeuroCure Cluster of Excellence, Charité — Universitätsmedizin Berlin, Campus Mitte, D-10117 Berlin, Germany

²Dept. of Cell Biology, Dorris Neuroscience Center, The Scripps Research Institute, La Jolla, CA, USA.

³Dorris Neuroscience Center and Department of Cell Biology, The Scripps Research Institute, 10550 North Torrey Pines Road, La Jolla, CA 92037, USA.

Comprised of functionally distinct neurons, the mammalian neocortex develops from progenitors lining the dorsal aspects of the lateral ventricles. The fate and position of these neurons is decided by the time they leave the germinal zone. However, little is known about how cortical progenitors learn how many neurons of each type to produce and when to make the switch from producing one neuronal type to the next. One source of instructions to the progenitors comes from the cortical plate itself, creating a feedback loop. However, the molecular identity and mechanism of action of these cortical feedback signals is poorly understood. Previously, we identified Sip1 as a master regulator controlling the timing of corticogenesis. Here we present data on the molecular control of deep layer to upper layer neuron switch during neocorticalogenesis.

Functional Analysis of STAR-Family Proteins during Oligodendrogenesis in the rodent Forebrain

Sabrina Schröder, Alexander von Holst¹

¹University of Heidelberg, Institute for Anatomy and Cell Biology, AG von Holst, Im Neuenheimerfeld 307, 69120 Heidelberg, Germany

Oligodendrocytes are essential for the myelination of axons in the central nervous system. During development oligodendrocyte precursor cells (OPCs) generate oligodendrocytes in a controlled and regulated process through the activity of diverse intrinsic and extrinsic factors. The members of the STAR-family proteins are among the intrinsic factors involved in oligodendrocyte differentiation. The STAR family (Signal transducer and Activator of RNA Metabolism) consists of the members Sam68 (Src - associated during mitosis of 68 kDa), SIm -1 and SIm -2 (Sam -like mammalian protein -1, -2). Characteristic of these proteins is the structural RNA -binding domain GRP33/SAM68/GLD -1 (GSG), which is flanked by regulatory regions containing motifs for protein-protein interactions and residues that are posttranslationally modified to control the activity of the STAR family proteins (Sette 2010). Due to this GSG domain, STAR family proteins are able to regulate alternative splicing events, RNA-transport and, additionally engage via the interaction with SH3-domain-containing proteins in signal transduction processes.

Another crucial factor for not only oligodendrocyte development but in general for neural stem cell differentiation is the extracellular matrix (ECM). During both embryogenesis and adulthood neural stem cells reside in specific niches rich in ECM components such as Tenascin C. Using the gene trap technology Sam68 was identified as a Tenascin C-regulated target gene in neural stem cells (Moritz et al., StemCells 2008). Due to the multifunctional character of Sam68 and his related family members SIm-1 and SIm-2 further studies were done in which Sam68 and SIm-1 were identified as promoters of neural stem cell (NSC) differentiation. Both proteins promote the differentiation of NSCs into a neuronal fate but also enhance oligodendrocyte maturation. However, the mechanism(s) how Sam68, SIm-1 and SIm-2 control oligodendrocyte development are still unresolved.

Therefore, we currently assess several Sam68 constructs, which contain mutations in the RNA-binding site or the nuclear localisation signal to characterize the relevant domains of Sam68 that control oligodendrocyte development by transfection of OPCs. Further investigation of the Sam68 expression pattern and the future characterization of the Sam68 knockout mouse will increase our understanding of the complex signalling pathways and function of the STAR-family proteins during oligodendrogenesis.

Chondroitinsulfotransferases and their role during forebrain development

Denise Harrach, Alexander von Holst^{1,2}

¹University of Heidelberg, Department of Anatomy and Cell Biology, Im Neuenheimer Feld 307, 69120 Heidelberg, Germany

²Interdisciplinary Center for Neurosciences (IZN), University of Heidelberg, Germany

Chondroitin sulfate proteoglycans (CSPGs) and their sulfation by chondroitin-sulfotransferases (Chsts) appear to play a crucial role for the behaviour of neural stem cells (NSCs) in the embryonic neural stem cell niche during mouse forebrain development. It has been shown that the inhibition of the sulfation by sodium chlorate or the degradation of the CSPG glycosaminoglycans by Chondroitinase ABC leads to less proliferation and altered cell fate decisions of the NSCs (Sirko, von Holst et al. 2007; Akita, von Holst et al. 2008; Sirko, von Holst et al. 2010).

The proliferation and differentiation of cortical neural stem cells from E13.5 mouse embryos upon forced expression of distinct Chst-EGFP constructs was examined by neurosphere forming assay and differentiation assay *in vitro*. Furthermore, the Chsts overexpression by CMV promotor vs. chicken β -actin promotor was analyzed.

The overexpression of distinct Chsts in the NSCs was functional as revealed by an increased signal for the complex sulfated CS -epitope detected by the monoclonal antibody 473HD. In the differentiation assay an increase in neurogenesis at the expense of gliogenesis was observed. In consistence with previous observations, the sulfation of the CSPGs plays a role in the commitment of the NSCs within the neural stem cell niche and could function as a possible communication platform between the NSCs and their extracellular surrounding in the neural stem cell niche.

Acknowledgements: The authors thank the DFG (Ho -2476/3-1) and the Institute for Anatomy & Cell Biology (Medical Faculty, University of Heidelberg) for financial support.

CDK5RAP2 expression during murine and human brain development correlates with cellular phenotype in MCPH3 patients

Lina Issa, Nadine Kraemer^{1,2}, Christian H. Rickert³, Olaf Ninnemann¹, Gisela Stoltenburg-Didinger¹, Deborah Morris-Rosendahl⁴, Angela M. Kaindl^{1,2}

¹Institute of Cell Biology and Neurobiology, Center for Anatomy Charité-Universitätsmedizin Berlin, Philipstr. 12, 10115 Berlin, Germany

²Department of Pediatric Neurology, Charité – Universitätsmedizin Berlin, Germany

³Institute of Pathology - Department of Neuropathology and Paediatric Pathology, Vivantes Clinics Friedrichshain, Berlin, Germany

⁴Institute of Human Genetics, University Clinic Freiburg, Germany.

Primary autosomal recessive microcephaly (MCPH) is a genetically heterogeneous neurodevelopmental disorder that results in severe microcephaly at birth with pronounced reduction in brain volume, particularly of the neocortex, and intellectual disability. MCPH gene products localize to the centrosome, pericentriolar matrix and spindle apparatus. A current model for the microcephaly phenotype invokes a premature shift from symmetric to asymmetric cell divisions and thus premature neurogenesis with a subsequent depletion of the progenitor pool. Still, the exact underlying pathomechanism remains to be definitely established.

Homozygous mutations of the Cyclin dependent kinase 5 regulatory subunit-associated protein 2 gene CDK5RAP2 cause MCPH type 3 (MCPH3). We confirmed CDK5RAP2 to be highly enriched at the centrosome and describe its spatiotemporal regulation during murine and human brain development. High Cdk5rap2 levels were detected during early neurogenesis in the murine brain, in both symmetrically and asymmetrically dividing progenitor cells. The protein is present in glial cells and early neurons but rare in mature neurons. Within the neocortex, Cdk5rap2 -positive cells localize particularly within the Cux1-positive upper layers. Cdk5rap2 also localizes to other brain regions than the neocortex, such as the hippocampus and the cerebellum. As the brain matures, Cdk5rap2 levels significantly decrease, and its spatial localization is refined to proliferation zones of the adult brain. Our findings of the Cdk5rap2 spatiotemporal localization in the murine brain holds also true for the human brain. Our results, showing the presence of Cdk5rap2 in progenitor cells early in neurogenesis but also in proliferative zones of the adult brain highlights a possible role of Cdk5rap2 in neural progenitor proliferation. Additional results from our studies performed on immortalized lymphocytes from human MCPH3 patients show that a loss of CDK5RAP2 function results in mitotic spindle defects and centrosomal disorganization. Thus, taken all together, our results underline that cell division defects in progenitor cells, possibly on the basis of a disruption of centrosome integrity/function and spindle defects, may play a role in the development of microcephaly in MCPH.

Astroglial connexins in adult neurogenesis: Gap junctional coupling is more important than adhesion.

Jiong Zhang, Peter Bedner¹, Stephanie Griemsmann¹, Radek Dobrowolski², Karen Maass², Robert Pascal Requardt^{2,3}, Indra Lübke-meier², Klaus Willecke², Christian Steinhäuser¹, Martin Theis¹

¹Institute of Cellular Neurosciences, University of Bonn, Bonn, Germany

²Institute of Genetic, University of Bonn, Bonn, Germany

³Jena University Hospital, Center for Sepsis Control and Care (CSCC), Jena, Germany

Gap junctional channels are comprised of connexins. The astrocytic connexin43 (Cx43) is involved in metabolite supply of neurons and extracellular K⁺ homeostasis, thus modulating neuronal activity. In the hippocampus, Cx43 is also expressed in neural stem cells, the so-called radial glia- (RG-) like cells of the subgranular zone (SGZ) in the dentate gyrus (DG). Throughout adult life, RG-like cells give rise to new neurons. Our previous data showed that Cx43 and/or Cx30 are required for proliferation of RG-like cells and adult neurogenesis. We now demonstrate that Cx43, but not Cx30, is crucial for adult neurogenesis. Cx43 also mediates adhesive interactions via the cytoplasmic C-terminal tail which might be involved in neurogenesis. For further mechanistic insight into connexin function, we studied Cx43 mutations: Mice expressing the point mutation Cx43G138R show selective loss of intercellular coupling, but should maintain adhesive properties since the C-terminus is unaffected. Cx43K258stop mice carry a C-terminal truncation of Cx43, which still showed intercellular coupling in transfected Hela cells, but adhesive interactions should be absent. Cx43D378stop mice lacking the last five amino acid residues of the C-terminal binding motif for ZO-1 still reveal functional gap junction channels and normal coupling properties in cardiomyocytes. Astroglia-specific Cx43G138R mice lacking Cx30 displayed no coupling in the hippocampus, as expected. Surprisingly, astroglia-specific Cx43K258Stop mice lacking Cx30 also exhibited uncoupling in the hippocampus. With immunohistochemistry, we found that both the proliferative activity in the SGZ and the number of newborn neurons in the DG were significantly decreased in astroglia-specific Cx43G138R and Cx43K258stop mice. We are currently investigating if Cx43D378stop mice show alterations in adult neurogenesis. Our findings so far strongly favor a role of Cx43-mediated intercellular coupling between RG-like cells rather than Cx43-mediated adhesive interactions for adult neurogenesis in the hippocampus.

Glial cell development in *Drosophila*: from cell fate specification to function

Benjamin Altenhein, Christian M. von Hilchen¹, Jan Dietrich¹, Alvaro E. Bustos¹, Andres de Visser¹, Tina K. Altenhein¹

¹University of Mainz, Institute of Genetics, J.-J.-Becherweg 32, 55099 Mainz, Germany

Cell fate specification in the developing nervous system of the fruit fly *Drosophila melanogaster* is a combination of positional information of the Neuroblast (NB), temporal specification within NB lineages and asymmetric distribution of determinants during mitosis. Recent work in our lab revealed that nearly all 35 glial cells within an abdominal hemineuromere of the fly embryo represent individual cell identities as reflected by a combinatorial code of marker gene expression and a stereotyped positioning, the latter being a consequence of an individual migratory behaviour of these cells. These specification events eventually result in functional diversification of the entire glial population which again is reflected by differential gene expression and hence morphological and physiological changes. Though glial cells play crucial roles in development and function of the nervous system of both invertebrates and vertebrates, the molecular genetic events that trigger specification of these cells is only poorly understood. I will present our recent approaches towards a better understanding of these specification steps, however not yet fully unravelled. Furthermore, I will show that differential expression of specific genes already early in glial development regulates glial and neuronal function in the mature nervous system. These functions influence cell-cell connections between glia and neurons, neurons and muscles, and among neurons and glia themselves. Loss of function of these factors in glia result in structural and/or physiological deficits of the flies, which will be demonstrated by different cell labeling and behavioral approaches. One of these genes is *kon-tik* (*kon*), the fly homolog of mouse/human NG2. Kon is expressed in a subset of glial cells from early development on and is required for proper proliferation of glial cells (comparable to the function of NG2 in the mammalian CNS) and the establishment of intact neuromuscular junctions in the larva. Another fly gene, *nazgul* (*naz*), is expressed in a well defined subset of neuropil-associated glial cells in the brain and the ventral nerve cord. *naz* encodes an oxidoreductase with homology to human retinol dehydrogenase 13. Loss-of-function mutations of *naz* in glial cells result in behavioral defects and an aberrant neuronal integration of sensory information in these animals. Another pair of genes that encode for members of the Ly-6 protein superfamily are expressed in glial cells of the peripheral nervous system (analogous to Schwann cells in vertebrates). These proteins, though expressed in glial cells, are located at the neuromuscular junction and apparently regulate the connectivity between motoneurons and muscles. Knock -down of either of these two genes leads to impaired locomotion, while overexpression has an opposing effect and leads to an increase in larval crawling speed. Taken together our data show that a clear understanding of glial cell specification from early development on is indispensable in order to better understand the various functions of these cells (not only in *Drosophila*).

Generation of Morbus Niemann-Pick Typ C1 Patient Specific Induced Pluripotent Stem Cells

Michaela Trilck, Rayk Hübner¹, Arndt Rolfs¹, Moritz J. Frech¹

¹University of Rostock, Albrecht-Kossel-Institute for Neuroregeneration, Gehlsheimer Straße 20, 18147 Rostock, Germany

Niemann-Pick type C1 (NPC1) is a rare progressive neurodegenerative disease, which is caused by a mutation in the NPC1 gene and is inherited in an autosomal recessive manner. In this lysosomal storage disorder the intracellular transport and sequestration of several lipids like cholesterol is severely impaired resulting in their accumulation in the late endosome and lysosome (LE/ L). The neurological manifestation of the disease is caused by dysfunction and death of neurons, astrocytes and microglia. However, the pathogenic mechanism is not completely understood. Several animal models like mouse, cat and *Drosophila* were used to analyze the impaired pathways but the loss of neurons is still unexplained and the genetic variability in humans cannot be reflected. Therefore, human models using patient-specific induced pluripotent stem (iPS) cells provide a promising approach. Here, we reprogrammed human fibroblasts from Morbus Niemann Pick Type C1 patient by retroviral transfection with Sox2, Klf4, Oct4 and cMyc. The pluripotency of the cells was analyzed by detecting the expression of several stem cell markers where cells were found to be positive for e.g. Nanog, Tra1-81 and SSEA4. Furthermore, cells could be differentiated into cells of all three germ layers demonstrating the pluripotency. The accumulation of cholesterol in different tissues is the main hallmark of NPC1 and is used for clinical diagnostics. Here, the cholesterol accumulation was visualized in both fibroblasts and iPS cells by Filipin staining. In addition, cells could be differentiated into neuronal cells, providing a potential model to study the pathogenic mechanisms of NPC1.

Roles of Neurod2/6 in Cortical Plate Formation and Establishment of Pyramidal Neuron Identity

Kuo Yan, Ingo Bormuth^{1,2,3}, Markus H. Schwab³, Klaus-Armin Nave³, Victor Tarabykin^{1,2,3}

¹Institute of Cell and Neurobiology, Charité - Universitätsmedizin Berlin, AG Tarabykin, , Phillipstrasse 12, 10115 Berlin, Germany;

²NeuroCure Cluster of Excellence, Berlin, Germany;

³Max-Planck-Institute for Experimental Medicine, Department of Neurogenetics, Göttingen, Germany

Basic helix-loop-helix (bHLH) transcription factors regulate biological differentiation processes ranging from cell determination to complex organ development. Neurod2 (NDRF) and Neurod6 (NEX) are structurally related neuronal bHLH proteins expressed in pyramidal neurons following similar spatial and temporal pattern. Inactivation of either one gene in mice does not affect pyramidal neuron differentiation or cortex development. However, Neurod2/6 double-mutant mice display drastic defects in neocortical connectivity (see Bormuth et al.).

Here, we analyze neuronal differentiation and the establishment of cellular identity in Neurod2/6 double mutant mice. When compared to controls, formation and regression of the temporal subplate layer is delayed in double mutants. Additionally, a subset of pyramidal neurons, however, does not express any of the tested layer specifically expressed marker genes. These cells fail to migrate into the cortical plate and accumulate in the subventricular zone. In contrast, a subset of upper layer neurons over-migrates into the marginal zone leading to individual cajal retzius cells spread throughout the cortical plate.

Currently, we are analyzing cortical layer organization, neuronal proliferation, differentiation, and molecular mechanisms underlying the defects.

MCPH and Effects of Cdk5rap2 Downregulation in Murine Embryonic Stem Cells

Nadine Krämer, Lina Issa^{1,2}, Gerda Neubert^{1,2}, Andrea Seiler³, Olaf Ninnemann¹,
Angela M. Kaindl^{1,2}

¹Charité - Universitätsmedizin Berlin, Institute of Cell Biology and Neurobiology, Berlin, Germany ²Charité - Universitätsmedizin Berlin, Department of Pediatric Neurology, Berlin, Germany

³Federal Institute for Risk Assessment, Berlin, Germany

Homozygous mutations in the cyclin dependent kinase 5 regulatory subunit-associated protein 2 gene *CDK5RAP2* cause primary autosomal recessive microcephaly type 3 (MCPH3). MCPH is a rare, genetically heterogeneous disease, characterized by a pronounced reduction of brain volume and mental retardation. Patients with MCPH develop severe microcephaly *in utero*, affecting particularly the cerebral cortex. CDK5RAP2 is a centrosomal protein and plays a role in various cellular processes such as centrosome functions, spindle formation and dynamics, kinetochore attachment to spindles, spindle checkpoint control, DNA repair and apoptosis. While deregulation of these processes most likely contributes to the human MCPH phenotype, the exact pathomechanism is still unknown. The aim was to analyze the pathomechanism underlying MCPH in an *in vitro* model.

To analyze the effects of Cdk5rap2 deregulation, we established an *in vitro* model through lentiviral *Cdk5rap2*-shRNAi infection of murine embryonic stem cells (mESC). These cells showed a stable downregulation of Cdk5rap2 and were used to study the effects on proliferation, differentiation and apoptosis in mESC.

Downregulation of Cdk5rap2 resulted only in a slight reduction of proliferation in undifferentiated mESC and the stem cell character was maintained. After induction of neural differentiation of Cdk5rap2 deficient mESC, a severe phenotype appeared with a gross loss of cells, which will be further analyzed (reduced proliferation, increased cell death). While in undifferentiated wildtype mESC Cdk5rap2 is localized at the centrosomes and thereby associated with the nucleus, the differentiation induction leads to a significant change of Cdk5rap2 localization with an assembly of Cdk5rap2 signals in the center of cell clusters, far away from the nucleus. These results indicate an important role of Cdk5rap2 in regulating the transition between symmetric and asymmetric proliferation and in polarization of differentiating cells.

Interactions between the meninges and the cortical neuroepithelium during mouse embryonic neurogenesis

Richard Sturm, Alexander von Holst¹

¹Institute for Anatomy and Cell Biology Heidelberg, AG von Holst, Im Neuenheimer Feld 307, 69120 Heidelberg, Germany

The numerous neuronal and glial cells that assemble to the complex structure of the mammalian dorsal forebrain originate from a pool of neural stem cells that line the lateral ventricle as a single cell layer early in development. The fate of each neural stem cell depends on the interplay between intrinsic programs and extrinsic signaling cues. The meninges covering the dorsal forebrain appear as a source for such extrinsic signaling factors. For instance the switch from proliferative to neurogenic divisions of a neural stem cell type, the Pax6 positive radial glia cell, is initiated by meningeal secretion of retinoic acid towards the ventricular zone of the dorsal forebrain. Therefore it is likely that also other meningeal derived factors are crucial at the onset and during neurogenesis. So, the aims of this study are to identify further signaling molecules, which are crucial for the interactions between the meninges and the dorsal forebrain during neurogenesis. Furthermore, possible feedback mechanisms that act from the developing dorsal forebrain towards the meninges will be investigated. To achieve these goals, I use a model system, where magnetically sorted Prominin-1 positive neural stem cells are co-cultured with meningeal cells. This elegant in vitro system allows to examine the effects of meningeal cells on the fate of neural stem cells and vice versa.

Following the analysis of the cell differentiation and proliferation behavior in the co-culture the transcriptional networks that influence the cell fate decisions will be disclosed. So, Foxc1 regulates the secretion of retinoic acid by the meninges. In turn, Pax6 appears to regulate Foxc1 expression. By using Pax6 deficient small eye mice for the co-culture, the influence of Pax6 on cell fate decisions are investigated. Besides, the influence of Pax6 deficiency on the expression of different transcription factors, including Foxc1 are analyzed by immunohistochemical methods and in situ hybridization.

New insights on Tgf β and FoxG1 crosstalk during embryonic brain development

Riccardo Vezzali, Tanja Vogel¹

¹Albert-Ludwigs-Universität Freiburg, Institut für Anatomie und Zellbiologie, Abteilung für Molekulare Embryologie, AG Vogel, Albertstr. 19, 79104 Freiburg, Germany

The pleiotropic cytokine Transforming Growth Factor β (Tgf β) exerts an antiproliferative and differentiative role in embryonic neurogenesis by activating the Smad pathway. This ultimately leads to the formation of a transcriptional complex, whose members comprise activated Smads and Forkhead box O (FoxO), which is responsible for the regulation of cell cycle regulator Cdkn1a (p21) expression. Another Forkhead box protein, FoxG1, can directly interact with the aforementioned complex, antagonizing Tgf β effects.

Results from our lab show that loss of FoxG1 at E13.5, when neurogenesis normally does not occur, grants the cells the capability to respond to Tgf β -mediated differentiating signals.

To understand which genes are regulated in a Tgf β -dependent manner in absence of FoxG1, microarray analysis was performed on Tgf β -treated cortical cells dissected from E13.5 FoxG1^{-/-} mice and controls.

FoxG1, like FoxO and the other Forkhead box proteins, can bind DNA directly through a specific consensus sequence. Candidate genes for further validations were selected based on the presence in their promoters of FoxG1 binding sequence and generic Smad binding sequence within a range of 200 bp from each other.

To inspect the Tgf β /FoxG1 crosstalk from different perspectives, validation was performed through Real-time RT-PCR in three different mutant mouse lines: FoxG1^{-/-} mice, Tgf β receptor 2 (Tgfbr2) conditional knockout mice (FoxG1cre;Tgfbr2flox), and Tgf β 2/Tgf β 3 double knockouts.

A total of 5 candidate genes, involved in functions spanning from cognition to synaptic plasticity to vascular development, are regulated in at least another mutant line aside from FoxG1^{-/-}. These genes will be further analyzed for FoxG1 binding ability through chromatin immunoprecipitation and immunohistochemistry, so to evaluate also their regulation and localization *in vivo*.

Astrocyte-assisted Neuronal Differentiation of iPSC Cells Derived from Skin Biopsies of Parkinson's Disease Patients with Genetic Alterations

Lisandro Jorge Falomir Lockhart, Michelle Gralle Botelho¹, Luis M.A. Oliveira¹, Sally K. Mak², Kun-Han Lin³, Holger Taschenberger³, Donna J. Arndt-Jovin¹, Birgitt Schuele², Thomas M. Jovin¹

¹Max Planck Institute for Biophysical Chemistry, Laboratory of Cellular Dynamics, Am Fassberg 11, 37077 Göttingen, Germany.

²The Parkinson Institute, 675 Almanor Ave, 94085 Sunnyvale (CA), USA.

³Max Planck Institute for Biophysical Chemistry, Research Group of Activity-Dependent and Developmental Plasticity at the Calyx of Held, Am Fassberg 11, 37077 Göttingen, Germany.

Parkinson's disease (PD) is the second most common neurodegenerative disorder. Its pathologic hallmark is the loss of dopaminergic neurons and the appearance of intracellular amyloid aggregates known as Lewy Bodies and Lewy Neurites. Although the majority of PD cases are sporadic, some familial mutations are known and they may hold the key to unraveling the initial molecular triggers leading to neurodegeneration.

Difficulties with the differentiation and culture of dopaminergic neurons have been mayor impediments to study the biochemistry and biology of PD. The ability to reprogram human somatic cells to induced pluripotent stem cells (iPSCs) provides an invaluable disease -relevant tool, especially since animal models do not reproduce essential features of the human disease. We are investigating iPSCs derived from patients with the most common genetic alteration associated with PD, the G2019S mutation of LRRK2, and the very rare triplication mutant of the gene for α -synuclein (aSyn), leading to protein overproduction and early onset disease.

We are differentiating iPSCs derived from fibroblasts of PD patients and healthy age-matched controls to dopaminergic neurons so as to identify the specific metabolic pathways and cellular processes affected, particularly in early stages. After a first step of partial differentiation into Neuronal Stem Cells (NSCs), iPSCs are further differentiated into functional neurons through a two-step protocol employing defined media that contain recombinant factors and B27 neuronal supplement (Zhang XQ & Zhang SC, 2010 *Methods Mol Biol* 584: 355 -366). Recently, the use of small molecules has been shown to be also beneficial in this process (Mak et al., 2012 *Stem Cells Int*: Article ID 140427), and supplements like cAMP appear to be essential in the case of LUHMES cells for obtaining a major fraction of neurons with a dopaminergic phenotype (Scholz D et al., 2011 *J Neurochem*; 119:957-71).

In addition, the hypothesis of an immune component in the etiology and progression of PD implies an involvement of accessory glial cells that establish a molecular crosstalk with the affected neurons and mediate propagation of cellular pathology. In this context, co cultures of rat or human astrocytes with the differentiating iPSC lines are of interest because they better approximate the cellular complexity of the central nervous system and reduce the requirements for exogenous growth and differentiation factors.

We have used specific antibodies against aSyn, TH, MAP2, β III-Tubulin and other markers to compare the differentiation of control and patient derived NSCs lines in the presence and absence of astrocytes. Cellular functionality was assessed by electrophysiology, mitochondrial respiration profile determination

(Seahorse XF24) and microscopy utilizing fluorescent probes specific for the subcellular fractions. Preliminary results suggest that astrocyte-conditioned media are beneficial for neuronal differentiation of NSCs. However, supplementation with specific factors or drugs may be required in order to achieve a high yield of dopaminergic neurons, particularly in the case of the lines with PD associated genetic alterations that exhibit difficulties in differentiation.

Tgf β -Igf signaling interplay in murine forebrain development

Shalaka Dhanraj Wahane, Riccardo Vezzali¹, Stefan Weise¹, Mirja T Prentzell^{2,3,4},
Kathrin Thedieck^{2,5,6}, Kerstin Krieglstein¹, Tanja Vogel¹

¹Albert Ludwigs University, Freiburg, Molecular Embryology, Freiburg, Germany, ²Institute for Biology III, Bioinformatics and Mol. Genetics, Albert-Ludwigs University, Freiburg, Germany, ³Spemann Graduate School for Biology and Medicine, Freiburg, Germany, ⁴Faculty of Biology, Albert Ludwigs University, Freiburg, ⁵BIOSS Centre for Biological Signalling Studies, Albert-Ludwigs University, Freiburg, ⁶Center for Systems Biology (ZBSA), Albert-Ludwigs University, Freiburg

Tgf β has been implicated in multiple cellular processes, ranging from neuronal differentiation, cell cycle exit, tumor suppression to tumor progression. Most of these molecular cues are context based as well as age dependent.

Previous data from the lab show an inclination of E16.5 cortical progenitors to enter a differentiative state upon Tgf β treatment, as compared to younger ones. This effect was most pronounced when cells of embryonic stage E16.5 were compared to those of E13.5. Thus it was evident that Tgf β functions dynamically during murine forebrain development. To delve deeper into molecular cues governed by Tgf β in an age-dependant manner, we performed a microarray using cortical progenitors from E13.5 and E16.5 mice. The resulting data showed a number of genes differentially expressed between the two developmental stages, and amongst these, members of the Insulin-Igf cascade seem to play a prominent role.

Insulin-Igf signaling (IIS) pathway plays a role in cellular proliferation, differentiation, survival and inhibition of apoptosis. We show that Igf-1 and Igf-2 have distinct gradients of expression in developing cortical cells (as well as murine forebrains) that result in time-dependent differential activation of downstream signalling pathways. Igf levels are highest during early forebrain development, and reduce with age. A decrease in mTOR levels and its readout too, is observed at E16.5 as compared to E13.5. Further proof of evidence is seen where Igf-1 exerts a pro-survival effect at E13.5, but not at E16.5. Inhibition of downstream targets of the Igf-1 cascade display reduced proliferation, indicating a role of Igf-1 in either cell survival and/or differentiation.

Tgf β pathway is known to interact with the Igf cascade at multiple levels, namely at PI3K, Akt, and FoxO. Molecular impudence of Igf-1r cascade, showed reduction in levels of downstream signalling cascade members of the canonical Igf-1 pathway, but despite this there was an evident Akt activation. We speculate an involvement of Tgf β pathway at this juncture, and convergence of Igf-1 and Tgf β pathways interacting together, to govern cell fate decisions in early murine forebrain development.

This study was funded through grants from the Deutsche Forschungsgemeinschaft.

This study was also supported in part, by the Excellence Initiative of the German Federal and State Governments (GSC-4) Spemann Graduate School)

Tgfbr2 conditional knock-out in developing telencephalon reveals neurovascular defects

Nicole Hellbach, Shalaka Wahane¹, Tanja Vogel¹

¹Albert-Ludwigs-University Freiburg, Institute of Anatomy and Cell Biology, Department Molecular Embryology, Albertstraße 17, 79104 Freiburg, Germany

To understand the role of transforming growth factor beta (Tgf-beta) in forebrain development, we characterize the function of Tgf-beta signalling *in vivo*. Since FoxG1 is expressed in progenitors and neurons of telencephalon, we used a FoxG1-cre *knock-in* mouse line to conditionally *knock-out* Tgfbr2.

In subcortical area of FoxG1^{cre/+}; Tgfbr2^{flox/flox} mutants we observed impaired vasculature, namely an atypical glomeruloid-like tufted appearance of vessels, reduction in branching and vessel amounts. These defects were seen only upon combined reduction of FoxG1 and *knock-out* of Tgfbr2. Since FoxG1 is not expressed in endothelial cells as well as pericytes, Tgfbr2 is still present in these cells.

This leads to the hypothesis that vascular defects arise from a miscommunication between neurons and vessels, possibly involving secretion in this process. To analyse altered secretion in mutants, we harvested conditional medium from neuronal cultures of FoxG1^{cre/+}; Tgfbr2^{flox/flox} and control tissues. We then stimulated HUVEC with this conditional medium to assess tube formation on a 2D-matrigel and confirmed a branching defect *in vitro* as well as a reduced tube length. HUVEC also showed impaired migration ability towards conditional medium of mutants as compared to that of controls.

Thus, we are analysing molecular signals of neuronal as well as progenitor origin that potentially affect endothelial development and maturation. We observe no change in expression of Vegfa on protein and RNA level. Nevertheless we detect an enhanced accumulation of Vegfa-complexes in the subcortical area of mutants. This implies a reduced Vegfa availability for endothelial cells and could lead to a disorganised tip and stalk cell formation, accompanied by less branching.

In conclusion, towards identifying a cause of leaky and unstable vessels, we hypothesise a combination of defects in:

1. signalling from neurons and progenitors
2. differentiation of endothelial cells
3. proper arrangement of extracellular matrix components
4. cell-matrix adhesion protein expression and arrangement.

Neuronal bHLH proteins Neurod2/6 regulate cortical commissure formation prior to midline interactions

Ingo Bormuth, Kuo Yan^{1,2}, Tomoko Yonemasu¹, Maike Gummert¹, Mingyue Zhang³, Sven Wichert¹, Olga Grishina^{1,2}, Alexander Pieper¹, Weiqi Zhang³, Sandra Goebbels¹, Victor Tarabykin², Klaus-Armin Nave¹, Markus Schwab¹

¹Max-Planck-Institute of Experimental Medicine, Department of Neurogenetics, Hermann-Rein-Str. 3, 37075 Göttingen, Germany

²Charité - University of Berlin, Institute of Cell- and Neurobiology, Philippstr. 12, 10115 Berlin, Germany

³University of Münster, Department of Psychiatry, Laboratory of Molecular Psychiatry, Albert-Schweitzer-Str. 11, 48149 Münster, Germany

Establishment of long-range fiber tracts by neocortical projection neurons is fundamental for higher brain functions. The molecular control of axon tract formation, however, is still poorly understood. Here, we have identified basic helix-loop-helix (bHLH) transcription factors Neurod2 (NDRF) and Neurod6 (NEX) as key regulators of fasciculation and targeted axogenesis in the mouse neocortex. In Neurod2/6 double mutant mice, callosal axons lack expression of the cell adhesion molecule Contactin2, defasciculate in the subventricular zone, and fail to grow towards the midline without forming Probst bundles. Instead, mutant axons overexpress Robo1 and follow random trajectories into the ipsilateral cortex. In contrast to long-range axogenesis, generation and maintenance of pyramidal neurons, and initial axon outgrowth are grossly normal suggesting that these processes are under distinct transcriptional control. Our findings define a new stage in corpus callosum development and demonstrate that neocortical projection neurons require transcriptional specification by neuronal bHLH proteins to execute an intrinsic program of remote connectivity.

Developmental changes in the composition of the olfactory bulb layers in the American Mink (*Neovison vison var. atratus*)

Elke Weiler, Willi Bennegger¹

¹Maria-von-Linden-Schule, Lebenswissenschaften, Heckentalstr. 86, 89518 Heidenheim, Germany

²Faculty of Medicine, Institute of Anatomy, University of Leipzig, Liebigstr. 13, 04103 Leipzig, Germany

The olfactory bulb is composed of neurons, arranged in typical layers: I) the outermost layer, the fila olfactoria layer (FILA) constitutes the axons of the olfactory sensory cells carrying the olfactory information input; II) in the glomerular layer (GLOM) the olfactory information is synaptically transmitted to the mitral cell apical dendrite within the glomeruli, surrounded by periglomerular interneurons; III) the external plexiform layer (EPL) is a processing layer, comprising the external dendrites of the granule cells synapsing to the mitral cell secondary dendrites; IV) in the mitral cell layer (MCL), the somata of these relais neurons are located; V) the internal plexiform layer (IPL), is a connecting layer, where mitral cell axons and granule cell dendrites pass; VI) the granule cell layer (GCL) contains the granule cell somata, the major interneurons for information processing; VII) in the stratum album (STR) many centrifugal fibers reach the bulb; VIII) the subependymal layer (SUB) surrounds the ventricle; IX) the ventricle (VEN) is seen prenatally.

During the postnatal development, the bulb grows continuously until adulthood, thus we were interested if the layers expand proportionally indicating same functional activity from birth on, or if the layers develop asymmetrically, pointing to activity-dependent network compositions. Therefore, we investigated histologically the olfactory bulb of the American mink (*Neovison vison var. atratus*), a species born very altricial in which a major part of development takes place postnatally.

A total of 36 males (aged newborns, postnatal day 1, P1, up to seven months, P210) were analyzed using a computer-assisted graphic tablet to measure the layers in nissl-stained frozen sections.

The total bulb volume increases in size continuously from $1.85 \pm 0.04 \text{ mm}^3$ at P1 to $152.00 \pm 9.14 \text{ mm}^3$ in adults, a 82-fold increase, however the composition pattern is highly significantly different. The inner layers (SUB P1: $7.43 \pm 0.42\%$, P210: $0.92 \pm 0.72\%$; STR P1: $16.98 \pm 0.47\%$, P210: $8.61 \pm 1.26\%$) decrease in proportion possibly due to the retraction of the ventricle and reduction of centrifugal migration, whereas the outermost layer (FILA) increases significantly in proportion (P1: $15.92 \pm 1.08\%$, P210: $26.90 \pm 5.18\%$). As shown earlier, the fila volume is rather correlated to the size of the animal than to the size of the brain; with the fact that the postnatal body size increase is unproportionally higher compared to brain size increase, the earlier findings are in line with our current result of postnatal increase in the FILA-proportion.

Furthermore, layers containing the cell bodies increase less in volume compared to the whole bulb (MCL 24-fold; GCL 70-fold), whereas the processing plexiform layers increase unproportionally more (EPL 361-fold; IPL 188-fold) so their proportion on the whole bulb increases postnatally (EPL: P1 $4.57 \pm 0.32\%$, P210 $19.16 \pm 2.74\%$, IPL: P1 $1.45 \pm 0.17\%$; P210 $3.74 \pm 0.54\%$). This indicates that the major changes are less related to the number of cells but to the size of neurons especially the expansion and branching of their processes. This suggests that at birth a great number of cells are already present while the formation of the neuronal network connectivity develops predominantly postnatally.

Thus, the olfactory bulb layers do not expand proportionally during postnatal development but the composition of the layers change according to their information processing and functional activity.

Role of histone modifications during cerebral cortex development

Deborah Roidl, Stefanie Heidrich¹, Jan Pruszek¹, Tanja Vogel¹

¹Institute of Anatomy and Cell Biology, Department of Molecular Embryology, Albert-Ludwigs-University, Freiburg, Germany

Precursor cells residing in ventricular and subventricular zones give rise to the adult cerebral cortex, which consists of six layers formed in an “inside-out manner” during development. Functionally specialized areas of the neocortex are formed through a gradient of gene expression in the neuroepithelium. This composition relies on a time dependent cell fate decision of precursor cells. Two genes proposed to regulate arealization are the paired -box transcription factor Pax6 and the empty spiracles homologue 2 Emx2. Pax6 is usually expressed in a high rostralateral and low caudomedial gradient whereas Emx2 shows an opposite gradient across the ventricular zone.

Recent advances in neuroscience support the importance of epigenetic modifications, such as methylation, acetylation and ubiquitylation of histones, for function and development of the central nervous system. Histone modifications are known to regulate gene transcription and they can be inherited to subsequent cell generations.

The aim of our project is to investigate differences in histone modifications of progenitors in rostral and caudal cortex of the developing neocortex, namely motor and visual cortex, and to reveal correlations to the transcriptome. Our speculation is that regional as well as temporal identities of progenitors are correlated with specific patterns of modified histones and that these patterns are necessary for proper specification of cellular identity within a certain cortical area.

We started our analyses with isolation of motor and visual cortices of E14.5 and E18.5 embryonic mouse brains, applied FACS to purify Pax6 and Emx2 positive cells of E18.5 cortices using specific antibodies and intend to perform ChIP-Seq.

To decide upon which histone modification we will use for ChIP-analyses, we study different histone modifications for spatio-temporal differences using Western Blots. Thus far, we observed expression changes between rostral and caudal cortex for H3K4 trimethylation (H3K4me3). This modification is linked to transcriptional activation and will therefore be the start of our ChIP-Seq analyses.

H3K79 methylation is described as being associated with transcriptional activity but also with transcriptional inert genomic regions. Moreover it has been shown that H3K79 methylation depends on the monoubiquitylation of H2B (H2Bub). Since a crosstalk between H3K4me3, H3K79me2/3 and H2Bub is known, we will include these histone modifications into our ChIP-analyses as well.

STAR Family Proteins: Cortical Expression Pattern and Function in Mouse Cortical Neural Stem/Progenitor Cells

Alexander von Holst, Bettina Bertam²

¹University Heidelberg, Anatomy and Cell Biology, INF 307, 69120 Heidelberg, Germany

²Ruhr-University Bochum, Cell Morphology and Molecular Neurobiology, 44780 Bochum, Germany

Sam68, a member of the STAR Family (Signal Transduction and Activator of RNA Metabolism) is a multifunctional RNA-binding protein involved in signal transduction, alternative splicing, mRNA translation and mRNA transport. So far the role of Sam68 and the related STAR Family proteins Slm-1 and Slm-2 (Sam like mammalian protein 1 and 2) during forebrain development are not well understood. In this study, the functional importance of the STAR Family during mouse forebrain development was analyzed by overexpression experiments in E13.5 cortical neural stem/progenitor cells (NSCs) with respect to differentiation and proliferation. In addition, immunohistochemical stainings were performed to expose the endogenous expression pattern of Sam68, Slm1 and Slm2 in the forebrain at developmental stages E13.5 and P10. The results indicate that forced expression of Sam68 and Slm-1 resulted in facilitated neuronal differentiation of NSCs, while the overexpression of Slm-2 exhibited an effect on the maintenance of NSC proliferation. A possible intracellular mechanism by which STAR proteins may affect NSC behaviour is the activity of the MAPkinase pathway, given that EGF stimulated ERK phosphorylation is reduced upon overexpression of STAR proteins while the response the FGF-2 is unaltered. In addition, Slm-2 overexpression inhibits oligodendrocyte differentiation and maturation.

Determination of the Tgfbr mediated proteome in the context of neurovascular development of the forebrain

Stefan Weise, Peer-Hendrik Kuhn^{2,3}, Nicole Hellbach¹, Stefan F. Lichtenthaler^{2,3},
Kathrin Thedieck^{4,5,6,7}, Tanja Vogel¹

¹Anatomy and Cell biology, Molecular Embryology, Albert-Ludwigs-University, Freiburg, Germany

²DZNE-German Center for Neurodegenerative Diseases, Munich, Germany

³Technische Universität München, Munich, Germany

⁴Institute for Biology III, Albert-Ludwigs-University, Freiburg

⁵Bioinformatics and Mol. Genetics, Albert-Ludwigs-University, Freiburg

⁶BIOS Centre for Biological Signalling Studies, Albert-Ludwigs University, Freiburg

⁷Center for Systems Biology (ZBSA), Albert-Ludwigs University, Freiburg

Tgf- β signaling has been shown to play a pivotal role during embryonic development and shows different effects on tumorigenesis. Amongst others it induces signals for differentiation, apoptosis and proliferation depending on tissue type and developmental stage.

Our group investigates the role of Tgf- β during development of the forebrain using a conditional Tgfbr2 knockout. FoxG1^{cre/+};Tgfbr2^{flox/flox} mice show intracranial bleedings in the forebrain beginning at developmental stage E12.5. Responsible for these bleedings is a defect in the formation of the neurovasculature, but molecular mechanisms behind these malformations remain elusive.

Here we make proteomic approaches to reveal these molecular mechanism. One approach employs combination of Stable Isotope Labeling with Aminoacids in Cell Culture (SILAC) of neurospheres from FoxG1^{cre/+};Tgfbr2^{flox/flox} forebrains, and mass spectrometry for analyses of protein differences in comparison to control cells. The proteome that is revealed through this approach promises to uncover candidate molecules implicated in the intracerebral hemorrhages of Tgfbr2-deficient mice, and will give new insights into the signaling pathways of neuronal progenitors.

The second attempt targets secreted proteins. In this approach, cells are cultured with a mannose-azide derivative. Prior to mass-spectrometric analyses, newly synthesized and secreted proteins are enriched from the medium by a click-reaction. Differences between the secretome of FoxG1^{cre/+};Tgfbr2^{flox/flox} and control cells will reveal relevant molecules affecting the development of the neurovasculature.

Combining the knowledge obtained from both, the proteome and the secretome, will shed light on the complex interplay between intra- and extracellular mechanisms of Tgf- β mediated signal transduction and provide novel ideas of neuron dependent regulation of angiogenesis.

Poster Topic

T2: Axon and Dendrite Development, Synaptogenesis

- T2-1A** Serotonin gradient is important for correct guidance of pioneer axons during mollusc and polychaete development
Elena E. Voronezhskaya, Viktor V. Starunov, Vyacheslav A. Dyachuk
- T2-2A** Wiring up sensory neocortex under conditions of massive cellular disorganization: does the thalamus find its ectopic target cells in *reeler* mutant mice?
Robin J. Wagener, Jochen F. Staiger
- T2-3A** Role of DHHC3 tyrosine phosphorylation in the control of its expression and functional activity
Tatiana Kuznetsova, Patricia Maria-Jeanne Lievens, Natalia Gorinski, Gaga Kochlamazashvili, Evgeni Ponimaskin, Alexander Dityatev
- T2-4A** LAYER 6B AS A REMNANT OF THE DEVELOPING SUBPLATE - A MORPHOLOGICAL COMPARISON
Manuel Marx, Ileana Hanganu-Opatz, Werner Kilb, Heiko Luhmann, Dirk Feldmeyer
- T2-5A** Functional Analysis of LRP4 During Dendritic Development
Andromachi Karakatsani, Stephan Kröger
- T2-6A** Isoform-specific functions of profilin1 and profilin2a in the mouse hippocampus
Sabine Zessin, Anita Remus, Martin Rothkegel, Martin Korte, Kristin Michaelsen-Preusse
- T2-1B** Postembryonic development of the locust mushroom body
René Eickhoff, Gerd Bicker
- T2-2B** Different approaches to enhance neuronal fibre growth in organotypic dopaminergic brain slice co-cultures
Katja Sygnecka, Claudia Heine, Nico Scherf, Heike Franke
- T2-3B** Regulation of synaptic structure and function by the Cdc42 GAP, NOMA-GAP
Steffen Schuster, Marta Rosário
- T2-4B** Neddylation controls dendritic spine development and stability: critical role of PSD-95 neddylation
Marisa Brockmann, Annette Vogl, Sebastian Giusti, Valentin Stein, Damian Refojo
- T2-5B** Role of NeuroD transcription factors in pyramidal neuron differentiation
Olga Grishina, Ingo Bormuth, Kuo Yan, Tomoko Yonemasu, Sandra Goebbels, Klaus-Armin Nave, Victor Tarabykin, Markus H. Schwab

- T2-6B** mAChR signaling in perinatal neocortex promotes expression of synaptic proteins
Petra Wahle, Olga Arne, Mohammad IK Hamad, Janine R Neumann
- T2-1C** The survival promoting peptide Y-P30 induces src phosphorylation in axonal growth cones
Martin Meschkat, Janine R Neumann, Petra Wahle
- T2-2C** Reelin and the Cdc42/Rac1 guanine nucleotide exchange factor aPIX/Arhgef6 promote dendritic Golgi translocation
Eckart Förster, Georg Rosenberger, Maurice Meseke
- T2-3C** Growth patterns of sensory neuron axon terminals in the developing olfactory bulb
Thomas Hassenklöver, Ivan Manzini
- T2-4C** Deciphering the neurexin code in the neuronal circuitry
Dietmar Schreiner, Thi-Minh-Phuc Nguyen, Jovan Simicevic, Alexander Schmidt, Peter Scheiffele
- T2-5C** Developmentally regulated changes of local proteomes at synaptic structures
Elmer Antileo Ibarra, Peter Landgraf, Thilo Kähne, Karin Richter, Karl-Heinz Smalla, Daniela C. Dieterich
- T2-6C** A Precise Temporal Coherency Between Receptor Expression, Neuronal Activity, and AP-1 Dependent Transcription Regulates Dendrite Development in an Identified Drosophila Motoneuron
Carsten Duch
- T2-1D** Dynamic maturation of the axon initial segment in the rodent visual system
Annika Gutzmann, Nursah Ergül, Christian Schultz, Petra Wahle, Maren Engelhardt
- T2-2D** NOMA-GAP CONTROLS DENDRITIC DEVELOPMENT OF NEOCORTICAL NEURONS BY REGULATING CDC42 AND COFILIN
Marta Rosário, Steffen Schuster, René Jüttner, Srinivas Parthasarathy, Victor Tarabykin, Walter Birchmeier
- T2-3D** A Co -Culture of Chicken Cochlear Ganglion and Auditory Brainstem Neurons to Investigate Regulation of Endbulb Synapse Formation in Vitro
David Goyer, Stefanie Kurth, Kai-Oliver Seibel, Hermann Wagner, Thomas Kuenzel
- T2-4D** A mechanical coupling between N-cadherin adhesion and F-actin flow stabilizes dendritic spines
Olivier Thoumine, Anael Chazeau, Mikael Garcia, Katalin Czondor, Amelie Argento, Gregory Giannone
- T2-5D** Impairment of neurite outgrowth in NGF -stimulated PC12 cells by antibodies directed to Neisseria gonorrhoeae, can be reversed by neuroleptic drugs *in vitro*
Bernhard Reuss
- T2-6D** Egr2::Cre mediated conditional ablation of Dicer disrupts histogenesis of mammalian central auditory nuclei

Elena Rosengauer, Heiner Hartwich, Anna Maria Hartmann, Anya Rudnicki, Somisetty Venkata Satheesh, Karen B. Avraham, Hans Gerd Nothwang

Serotonin gradient is important for correct guidance of pioneer axons during mollusc and polychaete development

Elena E. Voronezhskaya, Viktor V. Starunov², Vyacheslav A. Dyachuk³

¹ Institute of Developmental Biology Russian Academy of Sciences, comparative physiology, Vavilov str 26, 119334 Moscow, Russia

² Zoological Institute Russian Academy of Sciences, St-Petersburg, Russia

³ A.V. Zhirmunsky Institute of Marine Biology Far Eastern Branch of Russian Academy of Sciences, Vladivostok, Russia.

In trochophore animals two sets of neurons are the earliest to differentiate: apical cells and pioneer neurons. While apical cells release their neurotransmitter serotonin (5-HT) and serve as humoral regulators of developmental tempo (Voronezhskaya et al, 2004) and metamorphosis (Leise et al., 2001), processes of pioneer neurons (PN) are laying down the scaffolding for the developing nervous system (Croll, 2009; Nezhlin, 2010; Voronezhskaya and Ivashkin, 2010).

We used larvae of marine polychaete *Platinereis dumerilii* and bivalve mollusc *Mytilus trossulus* to investigate the role of serotonin (5-HT) on pioneer neurons axon guidance during development. *Platinereis* first PN is unpaired, 5-HT immunoreactive and located in the posterior extreme of the larvae. During normal development from early trochophore to metatrochophore processes of PN form two paired ventral nerve cords, prototroch nerve and the cerebral commissure. *Mytilus* first PN are paired, FMRFamide immunoreactive and located in ventral part of the episphere. During normal development from blastula to veliger processes of PN form cerebral commissure and ventral cords including fibers connecting rudiments of cerebral, pedal and visceral ganglia. Incubation in 5-HT (1-100 μ M) induced increase of 5-HT level within the whole larvae. After 24 hours of incubation a dramatic fibers malformations and axonal sprouting occurred in both species in a concentration-dependent manner. To the contrary, incubation in immediate 5-HT precursor, 5-HTP (10-100 μ M), induced enhancement in 5-HT level in specific neurons only, slightly slowing developmental tempo and did not affect axon growing and formation of nervous system scaffolding. Incubation in FMRFa (1-100 μ M) has no effects at all. Our investigation represent a first experimental evidence that 5-HT gradient produced during early larval development by neurons of the apical organ is essential for correct navigation of pioneer neurons axons. We suggested that polychaete and mollusc larvae are convenient models to investigate cellular and molecular mechanisms underlying process of axonal guidance during development.

The work was supported by RFBR grants 12-04-90844, 12-04-10119, 12-04-01510 and 12-04-33169.

Wiring up sensory neocortex under conditions of massive cellular disorganization: does the thalamus find its ectopic target cells in *reeler* mutant mice?

Robin J. Wagener, Jochen F. Staiger¹

¹University Medicine Goettingen, Dept. Neuroanatomy, Kreuzberggring 36, 37075 Goettingen, Germany

Developmentally, the ingrowth of thalamic axons into the cortex participates in defining the areal and thus functional specification of the neocortex. This process is governed by genetically determined molecular cues which are activity -independent. Thalamic projections from the ventral posteromedial thalamic nucleus (VPM) to rodent primary somatosensory cortex are highly ordered. In the mouse they mainly project to layer IV of the primary somatosensory cortex. There they form elliptically shaped patches within the center of a layer IV cellular aggregate called “barrel” and are able to functionally activate layer IV cells. The molecular mechanisms enabling thalamocortical axons to reach their target cells are poorly understood. However, gradients of axonal guidance molecules like semaphorins and ephrins as well as cell adhesion molecules like cadherins seem to play an important role in the process of fiber ingrowth, synapse formation and stabilization.

The *reeler* mouse is a homozygous *reelin*-deficient mutant, which shows a severely impaired cortical organization. Contrary to the still prevailing view of an inversion of layers, we found that cells with different laminar fates are mixed up and become distributed all over the cortical thickness. This is also true for cells that are fated for layer IV. These cells cluster in a columnar compartment building barrel equivalents, which can be functionally activated by behavioral tasks (Wagener et al., 2010). This raises the question if layer IV cells receive a thalamic input even in their ectopic position in the disorganized cortex. We now reconstructed the barrel equivalent as the main input compartment of thalamic fibers, as well as the distribution of thalamic fibers within the columnar equivalent. Moreover, we examined the composition of activated cells within the *reeler* columnar equivalent concerning their affiliation to excitatory and various subgroups of inhibitory cells.

We found that the thalamic axons form asymmetric patches, which strictly correspond to asymmetric barrel equivalents being smeared out over the cortical plate. In the disorganized *reeler* column the same composition of excitatory and inhibitory cells participate in the activation of neuronal networks as in the wild type column. Thus, thalamic axons are capable to establish highly ordered connections with their proper (layer IV) target cells even if they are found in a nearly random position. These connections must be highly ordered since they are capable to innervate exactly the same excitatory and inhibitory cell groups as in their wild type counterparts.

Thus, we suggest that cell-autonomous molecular cues and not gradients of attractive and repulsive factors are responsible for correct wiring in the thalamocortical pathway. The search is on for the precise identity of these molecular cues, which -once found- will be manipulated with in utero-electroporation approaches to test this hypothesis.

Role of DHHC3 tyrosine phosphorylation in the control of its expression and functional activity

Tatiana Kuznetsova, Patricia Maria-Jeanne Lievens¹, Natalia Gorinski², Gaga Kochlamazashvili¹, Evgeni Ponimaskin², Alexander Dityatev^{1,3}

¹Italian Institute of Technology (IIT), NBT (Neuroscience and Brain Technology), Via Morego, 30, 16163 Genova, Italy

²Institut für Neurophysiologie, Hannover Medical School, Carl-Neuberg-Straße 1, 30625 Hannover Germany

³Molecular Neuroplasticity, Deutsches Zentrum für Neurodegenerative Erkrankungen, Magdeburg, Germany

S-palmitoylation is a posttranslational addition of palmitate, a 16-carbon saturated fatty acid to cysteine residues through a labile thioester linkage, which is catalyzed by protein acyl transferases (PAT). Recently the zinc finger DHHC (Asp-His-His-Cys) type-containing protein family has emerged as a large family of palmitoyl acyltransferases with 23 members in the mouse and human genomes. Among them DHHC3 (also known as Golgi-specific DHHC zinc finger protein, GODZ) was shown as a relatively promiscuous palmitoyltransferase, which palmitoylate a broad range of substrates. These substrates includes signaling proteins (as several G protein alpha subunits), synaptic vesicle proteins (as SNAP-25 and cysteine-signaling protein), scaffold proteins (PSD-95), ion channels (gamma2 subunit of GABAA receptor; GluR1 and 2) and cell adhesion molecules (as alpha6 and beta4 integrin subunits and NCAM). Palmitoylation of neurospecific substrates of DHHC3 was shown to be important for synaptic function, plasticity, neuronal migration and maturation of neurons. Considering this, lack or gain of DHHC3 function could be a key point in progression of neurodegenerative diseases. So the exploration of regulation of DHHC3 activity is of the particular interest. Tyrosine phosphorylation is one of the most common regulatory posttranslational modifications and turns many protein enzymes on and off, thereby altering their function and activity. DHHC3 has several tyrosines which are potential sites for src and FGFR mediated phosphorylation. First we have shown that WT DHHC3 cotransfected in N2a cells with src or FGFR1 became highly tyrosine phosphorylated. Treatment of the cells with PP2 – a selective src inhibitor - reduces the phosphorylation of DHHC3, which is even more decreased if PP2 is applied together with FGFR inhibitor PD 173074. The DHHC3 Y-F mutant in which all 5 tyrosines (Y) at the cytoplasmic domains were mutated to phenylalanines (F) shows tyrosine phosphorylation neither under basal conditions nor in response to src or FGFR1 overexpression. Generating single and triple Y-F mutants (two sites 295, 297 on the C-terminus of the protein were mutated together) we were able to dissect the contribution of each site to the basal level of tyrosine phosphorylation and also to src or FGFR1 mediated hyperphosphorylation. Two tyrosines 295, 297 at the C-terminus of DHHC3 are responsible for activation directly by src-mediated pathway, while tyrosine located at the N-terminus of the protein in the position 18 is important for phosphorylation in response to signaling downstream of FGFR1. Interestingly, tyrosines 295, 297 contribute probably also to stability of DHHC3, since mutants lacking this site are expressed at significantly lower level than WT. It appeared that DHHC3 tyrosine phosphorylation interferes with its autopalmitylation: the full DHHC3Y-F mutant is 2 times more palmitoylated than the WT. The autopalmitylation gives insight into understanding the catalytically function of the enzyme, because in accordance with the two-step ping-pong theory autopalmitylation is an intermediate step in transferring the palmitate to the protein substrate. Hence, our ongoing study aims to verify if a lack of tyrosine phosphorylation of DHHC3 would affect its activity towards its substrates and play a role in the neuronal development and plasticity.

LAYER 6B AS A REMNANT OF THE DEVELOPING SUBPLATE - A MORPHOLOGICAL COMPARISON

Manuel Marx, Ileana Hanganu-Opatz², Werner Kilb³, Heiko Luhmann³, Dirk Feldmeyer^{1,4,5}

¹Institute of Neuroscience and Medicine (INM-2), Research Centre Jülich, 52425 Jülich, Germany

²Centre for Molecular Neurobiology Hamburg (ZMNH), University Medical Centre Hamburg-Eppendorf, D-20251 Hamburg, Germany

³Institute of Physiology and Pathophysiology, Johannes Gutenberg-University, D-55128 Mainz, Germany

⁴Department of Psychiatry, Psychotherapy and Psychosomatics, Medical School, RWTH Aachen University, D-52074 Aachen, Germany

⁵Jülich Aachen Research Alliance, Translational Brain Medicine (JARA Brain)

Neocortical lamina 6B (L6B) is the innermost and earliest generated layer of the distinct six-layered neocortex and has a very heterogeneous neuronal composition. In a recent study we identified five excitatory neuronal cell types based on a quantitative morphological and physiological analysis [Marx and Feldmeyer, *Cereb Cortex*, 2012]. Even the subplate (SP) consists of different multiple neuronal cell types and plays an important role during early development [Hanganu et al., *J Neurosci*, 2002]. L6B neurons are believed to be a remnant cell population from the developing subplate. Therefore, we compared the morphology of SP neurons aged 0-4 postnatal days (P0-4) with that of neurons in layer 6B (aged P17-24) of rat somatosensory barrel cortex. All neurons were investigated using whole-cell patch-clamp recordings and simultaneous biocytin fillings. A quantitative morphological comparison of subplate and layer 6B neurons was performed based on their three-dimensional reconstructions, their dendritic and axonal length density as well as polarity. A classification of SP neurons was made using an unsupervised cluster analysis. It revealed similar neuronal cell types for the subplate as found in layer 6B. Both SP and L6B neurons could be categorized into three main groups, namely (1) pyramidal-like/vertical neurons with a prominent dendrite towards the pial surface, (2) neurons with a prominent dendrite that was not oriented towards the pial surface and (3) multipolar/tripolar neurons without any preferential dendritic orientation. Neurons in the second group could be further subdivided into those with an inverted, 'horizontally'- and 'tangentially'-oriented 'apical'-like dendrite. In addition, we found that a change in the relative fraction of the different neuronal cell types occurred: pyramidal cells were more prominent in layer 6B while neurons with an 'apical'-like dendrite were less common. The fraction of multipolar neurons remained unaltered. In conclusion, our data suggest that SP neurons are indeed comparable to the different neuronal cell types of layer 6B and persist at least in part into adulthood.

Functional Analysis of LRP4 During Dendritic Development

Andromachi Karakatsani, Stephan Kröger¹

¹Institute of Physiology, Department of Physiological Genomics, Pettenkoferstrasse 12, 80336 Munich, Germany

The low-density lipoprotein receptor-related protein (LRP) family of transmembrane proteins in mammals consists of ten members (Herz, 2001; May and Herz, 2003) which are well known for their roles in lipid metabolism, cholesterol homeostasis and Wnt signaling.

We have started to analyze the role of LRP4, during the development of the central nervous system. LRP4 is concentrated at the neuromuscular junction where it forms a complex with the tyrosine kinase MuSK and serves as the receptor for the synapse-inducing molecule agrin (Weatherbee et al., 2006; Kim et al., 2008; Zhang et al., 2008). Recently it has been shown that LRP4 also functions as a direct muscle-derived retrograde signal that is necessary and sufficient for presynaptic differentiation (Wu et al., 2012; Yumoto et al., 2012). Mice with a targeted deletion of LRP4 have no pre- and postsynaptic specializations at the neuromuscular junction (Weatherbee et al., 2006). LRP4 is also concentrated in the postsynaptic membrane of CNS synapses where it interacts with postsynaptic scaffold proteins, including PSD-95 (Tian et al., 2006).

Despite its widespread expression, and its concentration at adult interneuronal synapses, the role of LRP4 during development of the CNS is unknown. To test the hypothesis that LRP4 might have similar functions during CNS development as it has at the neuromuscular junction, primary neuronal cultures from mouse cortex were used to study the role of LRP4 during process formation, dendritic arborization and synapse formation in the CNS in vitro. We analyzed the effect of LRP4 overexpression and knock-down on dendritic process number, length and complexity as well as spine density. In order to visualize the details of neuronal morphology we expressed a GFP-Actin construct together with either LRP4 or microRNAs specifically directed against LRP4. Our data suggest an important role of LRP4 during development of synapses in the CNS and support a function for LRP4 in the CNS that is similar to its function at the neuromuscular junction.

Isoform-specific functions of profilin1 and profilin2a in the mouse hippocampus

Sabine Zessin, Anita Remus¹, Martin Rothkegel¹, Martin Korte¹, Kristin Michaelsen-Preusse¹

¹TU Braunschweig, Cellular Neurobiology, Spielmannstr. 7, 38106 Braunschweig, Germany

The dynamic reorganization of the actin cytoskeleton is believed to be crucial for activity dependent structural plasticity and therefore most likely of significant importance for processes of learning and memory formation. Structural remodeling of the actin cytoskeleton requires a sophisticated spatial and temporal regulation mediated by numerous actin binding molecules. Among these, profilin is of key interest as it facilitates actin polymerization. It is highly enriched in dendritic spines and the distribution of profilin has been shown to be regulated by neuronal activity. In the mammalian brain, there are two profilin isoforms: profilin1 (PFN1) which is ubiquitously expressed in all cells and the brain specific isoform profilin2a (PFN2a). Interestingly, we could show recently by RNAi-mediated knockdown of PFN2a that it has indeed an isoform-specific role in mediating dendrite stability (Michaelsen et al. 2010). In order to gain a more comprehensive understanding of the specific role of PFN1, we performed acute RNAi-mediated knockdown in organotypic slice cultures of the murine hippocampus via single-cell electroporation as well as biolistic transfection using the gene gun method. With these means we could show that the knockdown of either PFN1 or PFN2a results in distinct effects on neurite structure, spine morphology and spine dynamics.

Our hypothesis that both profilins serve at least in parts individual functions in mediating spine morphology and plasticity is further supported by the finding that both isoforms are regulated differentially in the mouse model of the Fragile X syndrome (FXS), a neurological disorder known to affect spine development and function. FXS is characterized by impairments in cognitive function and social behavior. In addition to this, it has an impact on spine size as well as structural dynamics in the neocortex and hippocampus. Therefore, we hypothesized that part of the phenotype is the result of misregulated actin dynamics in dendritic spines. The responsible mutation in the *fmr1* gene causes a loss of the Fragile X mental retardation protein (FMRP) involved in the regulation of mRNA transport. Previous studies in *Drosophila* showed an interaction of FMRP and the mRNA of chickadee (homolog of profilin).

Interestingly, western blot analysis of whole brain lysates of *fmr1* KO and WT mice revealed that the protein levels of PFN1 were decreased in the KO animals while in contrast to this finding PFN2 levels remained unaltered compared to WT mice. Moreover, the amount of cofilin, another major modulator of actin dynamics, was found to be increased in *fmr1* KO mice.

Taken together, our data further underline the fact that the two profilin isoforms fulfill distinct roles in regulating neuronal architecture. Future experiments will investigate the detailed mechanisms of an isoform-specific involvement in spine dynamics and structural plasticity. In this regard, the FXS mouse model can be used as a valuable tool to provide further insight into the specific functions of profilin isoforms in spine development and processes of synaptic plasticity.

Postembryonic development of the locust mushroom body

René Eickhoff, Gerd Bicker¹

¹Tierärztliche Hochschule Hannover, AG Zellbiologie, Bischofsholer Damm 15/102, 30173 Hannover, Germany

We have recently shown that developing mushroom bodies in the locust express the axonal guidance molecules Semaphorin 1a (Sema 1a) and Fasciclin I (Fas I). Whereas Sema 1a expression correlates with onset of neuropil formation Fas I expression in the mushroom bodies occurs rather late during embryogenesis. Consistent with what is known from other hemimetabolous species, locust Kenyon cells are generated throughout the larval stages. Lachesin immunolabeling of newborn Kenyon cells suggests that postembryonic growth of the locust mushroom bodies involves both olfactory and gustatory (Class III) Kenyon cells. Outgrowing Kenyon cells in larvae retain the embryonic expression pattern of Sema 1a and Fas I, indicating a role for these molecules in developmental mushroom body plasticity. This study provides the groundwork for functional experiments e.g. to examine the significance of Sema 1a and Fas I expression during locust mushroom body formation.

Here, we present preliminary results derived from a series of in vitro experiments with larval brain culture. Brains of L1 larvae were desheathed and then incubated for several hours to follow postembryonic mushroom body development. To test for the function of Sema 1a and Fas I in the developing locust brain we performed antibody blocking experiments. In addition we interfered with cyclic nucleotide pathways to better understand the mechanisms of Sema 1a signalling in the locust brain. We set the focus not only on Kenyon cell outgrowth but also on Kenyon cell proliferation.

Different approaches to enhance neuronal fibre growth in organotypic dopaminergic brain slice co-cultures

Katja Sygnecka, Claudia Heine^{1,2}, Nico Scherf³, Heike Franke²

¹Universität Leipzig, TRM Leipzig, Philipp-Rosenthal-Straße 55, 04103 Leipzig, Germany

²Universität Leipzig, Rudolf Boehm Institute of Pharmacology and Toxicology, Härtelstr. 16-18, 04107 Leipzig, Germany

³Dresden University of Technology, Institute for Medical Informatics and Biometry, Blasewitzer Strasse 86, 01307 Dresden, Germany

The regeneration of neuronal fibres and neuronal projection pathways are important processes in neuronal plasticity during development as well as after different kinds of acute CNS injury (e.g. mechanical tissue injury) and in neurodegenerative diseases (e.g. Parkinson's Disease).

With our organotypic brain slice co-culture model consisting of the ventral tegmental area/substantia nigra (VTA/SN) and either prefrontal cortex (PFC) or striatum (STR) we reconstruct the mesocortical and the nigrostriatal dopaminergic system, respectively under *ex vivo* conditions. As the dopaminergic projections in neonatal mouse or rat brains are cut during preparation, the co-cultures present all at once a model of mechanical injury. Moreover the situation in the established *ex vivo* model strongly correlates with the development of fibre projections of physiological neuronal circuits. Using this model, we investigated different approaches with regard to their fibre growth enhancing properties: (A) *enzyme inhibitors* (phosphodiesterase – inhibitors (PDE – I)), (B) *receptor agonists* (purinergic agonists), (C) *mesenchymal progenitors* (mesenchymal stem cells (MSC), very small embryonic like stem cells (VSEL)) and (D) *growth factors* (NGF; BDNF) as positive controls.

Therefore we applied biocytin tracing and a specially tailored automated image analysis to quantify the density of fibres interconnecting the dopaminergic VTA/SN with the target region PFC or STR, respectively. Furthermore culture medium was collected for LDH activity measurement after substance treatment. Immunofluorescence stainings were conducted to evaluate general morphological features of the brain slices after cultivation period and to reveal the presence of the correspondent compound targets in the brain slices, especially on fibres in the border region of the co-cultures.

We found that selected PDE2 – I are potent fibre growth enhancing substances in the nigrostriatal projection system. Moreover a fibre growth promoting effect has been observed after application of purinergic agonists on co-cultures of the mesocortical projection system. Likewise the cultivation of MSC or VSEL underneath the co -cultures (VTA/SN//PFC) promoted directed neuronal fibre growth. No significant changes of LDH release have been found in the investigated samples after substance treatment. Therefore a toxicological effect evoked by the substances can be excluded.

These exemplary studies show that the presented co-culture model perfectly meets the requirements to study neuronal fibre growth promoting properties of various compounds or selected cell populations.

Regulation of synaptic structure and function by the Cdc42 GAP, NOMA-GAP

Steffen Schuster, Marta Rosário¹

¹Charité-Universitätsmedizin Berlin, Institute of Cell Biology and Neurobiology, Charitéplatz 1, 10117 Berlin, Germany

The dendritic tree morphology and dendritic spine structure is critical for establishing neuronal connectivity and normal brain function. Alterations in dendritic arborization and dendritic spine morphology are associated with neurological disorders such as mental retardation. Recently we have shown that NOMA-GAP, a RhoGAP specific for Cdc42, is a major regulator of dendritic complexity in layer 2/3 pyramidal neurons in the murine neocortex.

Here, we find that NOMA-GAP is critical for spinogenesis and synaptogenesis in the murine neocortex. NOMA-GAP forms complexes with postsynaptic proteins localize to excitatory postsynaptic sites. Furthermore we assess the role of NOMA-GAP in dendritic spine and synapse formation using NOMA-GAP deficient mice and demonstrate various defects in this process. In addition NOMA-GAP deficient mice show abnormal behaviour and a change in excitatory postsynaptic currents.

These results show that NOMA-GAP plays an essential role in the specification of dendritic structures and synaptic function of pyramidal neurons of the murine neocortex.

Neddylation controls dendritic spine development and stability: critical role of PSD-95 neddylation

Marisa Brockmann, Annette Vogl¹, Sebastian Giusti¹, Valentin Stein², Damian Refojo¹

¹MPI für Psychiatrie, Molekulare Neurobiologie, Kraepelinstraße 2-10, 80804 München, Germany

²Institut für Physiologie, Universität Bonn, Nussallee 11, 53113 Bonn, Germany

The interaction and functional modulation of many proteins is required to orchestrate the complex process of neuronal development and synaptogenesis. Especially the interaction of postsynaptic proteins with AMPA and NMDA receptors has been studied in the past ten years. The modulatory effects of the well known posttranslational processes phosphorylation, sumoylation, and ubiquitylation have been studied in detail. Ubiquitylation and other Ubiquitin-like proteins (UBLs) pathways like sumoylation have in common the covalent binding of ubiquitin or UBLs to specific target proteins and thereby changing the function, localization, protein-protein interaction or stability of target proteins. Both Ubiquitin and Sumo are post-translational modifications involved in a myriad of neuronal functions e.g. neuronal survival, dendritic arborization, axonal growth, spine formation, synaptic pruning, and trafficking of glutamate receptors. However, the putative role of the ubiquitin-like protein Nedd8 in neurons remains unknown. Similar to other UBLs, the neddylation pathway requires three steps of activation (E1), conjugation (E2) and ligation (E3) of the UBL Nedd8. Nedd8 is 8% homologous to Ubiquitin.

Here we show that Nedd8 and the specific E1 enzyme Nae1 and the E2 enzyme Ubc12 are highly expressed in the brain. In addition, the expression profile of the proteins involved in the Nedd8 conjugation changes during postnatal development and the amount of neddylated proteins peaks with synaptogenesis. Furthermore, we found that many synaptic proteins are indeed neddylated and that inhibiting neddylation leads to massive effects on dendrite and spine morphology.

Importantly, we identified PSD-95 as a substrate of the neddylation pathway. Preventing the neddylation of PSD-95 by mutation of neddylated Lysine residues changes spine morphology and synaptic transmission.

In summary, we propose that neddylation is a new posttranslational modification pathway in neurons that regulates different aspects of synaptic development and function. These results as well as some of the mechanisms behind including potential synaptic targets will be discussed.

Role of NeuroD transcription factors in pyramidal neuron differentiation

Olga Grishina, Ingo Bormuth^{1,2}, Kuo Yan^{1,2}, Tomoko Yonemasu², Sandra Goebbels², Klaus-Armin Nave², Victor Tarabykin¹, Markus H. Schwab²

¹Charité - University of Berlin, Institute of Cell- and Neurobiology, Philippstr. 12, 10115 Berlin, Germany

²Max-Planck-Institute of Experimental Medicine, Department of Neurogenetics, Hermann-Rein-Str. 3, 37075 Göttingen, Germany

Basic helix–loop–helix (bHLH) transcription factors are involved in differentiation processes during the development of most tissues and species. Some of them can by themselves determine cellular fate as shown for Myogenin in muscle formation or the Neurogenins in early forebrain development. A group of closely related bHLH Proteins termed Neurod1, -2 and -6 are specifically expressed in already determined neurons of the cerebral cortex presumably driving terminal differentiation of these cells. It was shown that inactivation of Neurod1 is sufficient to halt granule cell differentiation in the dentate gyrus resulting in apoptosis of most of these cells. Pyramidal neuron differentiation, however, is not strongly affected by loss of either Neurod1, -2 or -6. We speculated that the three genes might share a common redundant function and generated double- and triple mutant mice. Only after simultaneous deletion of Neurod1, -2 and -6, postmitotic pyramidal neurons fail to differentiate terminally and instead undergo apoptosis. Using these triple mutant mice, we seek to identify and characterize the NeuroD-controlled molecular program of terminal pyramidal neuron differentiation in the hippocampus.

mAChR signaling in perinatal neocortex promotes expression of synaptic proteins

Petra Wahle, Olga Arne¹, Mohammad IK Hamad¹, Janine R Neumann¹

¹Ruhr University Bochum, Ag Entwicklungsneurobiologie, Universitätsstraße 150, 44780 Bochum, Germany

Cholinergic signalling via muscarinic receptors to the immature neocortex has been shown to evoke spindle oscillations and oscillatory network activity by triggering mainly glutamatergic transmission of subplate neurons. We have been asking whether perinatal repetitive mAChR signalling could alter acutely or long-term the expression of proteins. We used organotypic slice cultures of rat visual cortex prepared from the newborn. Slices were acutely stimulated with carbachol at day 5, or at day 10 for 0.25-4 h to assess the kinetics of protein expression. In addition, cultures were repetitively stimulated with daily pulses from days 1-5 followed by analysis <5h after the last pulse at day 5, or after another 5 and 15 days without further stimulation at day 10 and day 20. We found that one pulse of carbachol at day 5 activated p21 ras, evoked an ERK phosphorylation, and increased the expression of BDNF mRNA and c-fos. Further, one pulse of carbachol evoked within 15-30 min an increase in the protein expression of NMDA receptor subunits NR1, NR2B, NR2A, of GAD-65 and synaptophysin, but not of GAP-43 or GAD-67. The same experiment at day 10 resulted in an increase of only NR2A. After day 1-5 repetitive stimulation we observed an increased expression of NR1, NR2B, NR2A, PSD-95, GAD-65 and synaptophysin. NR2A and synaptophysin were still higher than untreated control at day 10 indicating a longer lasting increase, but none was different from control at day 20. The results suggest that a mAChR activation in the perinatal cortex triggers network activity and this increases- presumably by translational mechanisms - the expression of proteins important for activity-dependent differentiation and synaptic plasticity.

We thank the Schram Foundation for funding.

The survival promoting peptide Y-P30 induces src phosphorylation in axonal growth cones

Martin Meschkat, Janine R Neumann¹, Petra Wahle¹

¹Ruhr Universität Bochum, AG Entwicklungsneurobiologie, Universitätsstraße 150, 44780 Bochum, Germany

The survival promoting peptide Y-P30 has a variety of neurotrophic actions. It has been shown to promote survival of cortical neurons after stab wounding. It promotes the survival of adult rat retinal ganglion cells after optic nerve crush *in vivo*. It increases the speed of migration of T24 bladder carcinoma cells, PC12 cells and primary cortical astrocytes, and promotes the growth of axons. Y-P30 enhances the interaction of two Y-P30 binding partners, pleiotrophin and syndecan -2/3; both are implicated for instance in axonal growth. We aimed to further characterize the signaling mechanisms. Stimulating cortical organotypic slice cultures with Y-P30 induces within minutes the phosphorylation of src kinase and p42/p44 ERK kinases. In cortical microexplants cultured for 3 days and stained for actin or for GABA, we found that Y-P30 within 60-90 minutes decreases the fraction of collapsing and degenerating axonal growth cones. The action was prevented by the MEK inhibitor U0126 and the src inhibitor PP1. This suggested that Y-P30 stabilizes axonal growth cones in an ERK- and src-dependent manner. Using confocal imaging we quantified the immunofluorescence levels of selected proteins in axonal growth cones in DIV 3 cortical microexplant cultures stimulated with Y-P30 for 60-90 minutes or for 12-24 h followed by staining under identical conditions. The average level of total actin, growth-associated protein GAP-43, and cortactin remained unchanged at the levels seen in untreated control cultures. By contrast, the level of phosphorylated src was increased in acutely stimulated growth cones, but returned to the level of untreated cultures after 12-24 h. This suggested that Y-P30 exerts its axonal growth promoting action via src signaling.

Reelin and the Cdc42/Rac1 guanine nucleotide exchange factor aPIX/Arhgef6 promote dendritic Golgi translocation

Eckart Förster, Georg Rosenberger², Maurice Meseke¹

¹University Medical Center Hamburg-Eppendorf, Institute of Neuroanatomy, Martinistr. 52, 20246 Hamburg, Germany

²University Medical Center Hamburg-Eppendorf, Institute of Human Genetics, Martinistr. 52, 20246 Hamburg, Germany

In the cerebral cortex of reeler mutant mice lacking reelin expression, neurons are malpositioned and display misoriented apical dendrites. The development of an apical dendrite requires transient dendritic translocation of the Golgi apparatus, which has recently been shown to be promoted by reelin. However, the underlying signalling mechanisms are unknown. For instance, we have recently shown that reelin promotes the growth of microtubule plus ends in neuronal processes, as reflected by increased +TIP EB3 dynamics (Meseke et al., 2012). Here, we show that the Cdc42/Rac1 guanine nucleotide exchange factor aPIX/Arhgef6 promotes translocation of Golgi cisternae into developing dendrites. Reelin treatment further increased the aPIX-dependent effect. In turn, overexpression of exchange activity-deficient aPIX or of dominant-negative Cdc42 or Rac1 impaired dendritic Golgi positioning, an effect that was not compensated by reelin treatment. Reelin stimulation did not rescue the inhibition of Golgi translocation by dn-Cdc42 or dn-Rac1, suggesting that reelin promotes dendritic Golgi positioning via Cdc42/Rac1. Together, these data suggest that aPIX is involved in the promotion of dendritic Golgi translocation, optionally as a component of a reelin modulated signalling pathway.

Reference

Meseke M, Cavus E, Förster E. (2012). Reelin promotes microtubule dynamics in processes of developing neurons. *Histochem Cell Biol.* [Epub ahead of print]

Growth patterns of sensory neuron axon terminals in the developing olfactory bulb

Thomas Hassenklöver, Ivan Manzini^{1,2}

¹University of Göttingen, Neurophysiology and Cellular Biophysics, Humboldtallee 23, 37073 Göttingen, Germany

²DFG Research Center for Molecular Physiology of the Brain (CMPB), 37073 Göttingen, Germany

The developing, but also the mature, vertebrate olfactory system is a site of ongoing neurogenesis. Olfactory stem cells continuously generate new sensory neurons which extend long axons into the olfactory bulb where they face the challenge to integrate into existing circuitry. Synaptic contacts to second-order neurons are formed in distinct target regions, so-called glomeruli. In rodents, sensory neurons normally project only into one specific glomerulus of the olfactory bulb.

We investigated the growth patterns of sensory neuron axons in the developing olfactory system of the aquatic amphibian *Xenopus laevis*. To address the question how connectivity is reshaped during olfactory system maturation a range of larval stages and young postmetamorphic animals were included in the experiments. Fluophore-coupled dextrans or plasmid DNA, encoding for fluorescent proteins, were introduced into sensory neurons via electroporation. The main sensory projection fields within the olfactory bulb, namely the accessory olfactory bulb and a lateral, intermediate and medial glomerular cluster in the main olfactory bulb were visualized by electroporation of the whole olfactory organ. During metamorphosis the main olfactory system is completely reorganized, whereas the sensory neurons of the accessory olfactory system are maintained. The axonal branching patterns of sensory neurons, originating from both the vomeronasal and main olfactory epithelium, were investigated by sparse staining of sensory neurons. Synaptic connections were clearly visible as tufted axonal endings. Most sensory neurons showed a branched axonal pattern before terminating in tufted arborizations inside glomeruli. Surprisingly, a high percentage of cells terminated in multiple and not single glomerulus-like structures. This pattern was comparable in sensory neurons originating from both the vomeronasal and the main olfactory organ.

[Supported by DFG Research Center Molecular Physiology of the Brain (CMPB) to I.M.]

Deciphering the neurexin code in the neuronal circuitry

Dietmar Schreiner, Thi-Minh-Phuc Nguyen¹, Jovan Simicevic¹, Alexander Schmidt¹,
Peter Scheiffele¹

¹Biozentrum / Uni Basel, Cell biology / Neurobiology, Klingelbergstrasse 50-70, 4056 Basel, Switzerland

Neuronal circuits are comprised of a specific sets of neurons interconnected in a highly precise manner. It has been hypothesized that neuronal cell populations as well as individual neurons within a population carry molecular recognition tags which define their 'identity'. Such an identity would represent a key determinant of the selective wiring and functional properties of individual neurons in neuronal circuits.

Neurexins (NRX) are important synapse organizing molecules and were demonstrated to play a pivotal role in the synapse formation. Through alternative splicing of transcripts derived from three NRX genes thousands of isoforms can be generated, making these proteins good candidates as determinants of some aspect of neuronal identity, wiring specificity and/or synaptic properties. Understanding the spatiotemporal logic of NRX isoform expression in the brain as well as their biochemical properties represents an important step towards elucidating the function of NRX diversity. However, the complexity of the neurexin isoforms and the lack of suitable tools has greatly limited such analyses, in particular on the protein level.

By combining Selected Reaction Monitoring (SRM) mass spectrometry and mRNA analysis of different brain areas, biochemical preparations and specific neuronal cell populations we reveal highly specific patterns of NRX isoform and splice variant expression. Cell type specific alternative splicing of NRX transcripts could be uncovered by splice reporters. These expression patterns are complemented by functional experiments on binding and adhesive interactions of neurexin isoforms with synaptic interaction partners. In summary, our work provides important information for the understanding of the NRX alternative splicing in the regulation of the formation and specific properties of synaptic connections.

Developmentally regulated changes of local proteomes at synaptic structures

Elmer Antileo Ibarra, Peter Landgraf^{1,2}, Thilo Kähne³, Karin Richter⁴, Karl-Heinz Smalla², Daniela C. Dieterich^{1,2}

¹Institute for Pharmacology and Toxicology, Otto-von-Guericke University, Magdeburg, Germany. ²Leibniz Institute for Neurobiology, Magdeburg, Germany. ³Institute of Experimental Internal Medicine and, ⁴Institute of Biochemistry and Cell Biology, Otto-von-Guericke University, Magdeburg, Germany.

Synapses are the major mediators of neuronal communication in the nervous system. Their establishments during brain development, a process also known as synaptogenesis, as well as long lasting forms of synaptic plasticity are characterized by dynamic changes of the neuronal proteome. Besides posttranslational modifications and directed protein degradation, the synthesis of new proteins plays a vital role for synaptic function. Interestingly, neurons are capable of synthesizing proteins not only in the soma but also locally in distal parts of their dendrites. The feasibility of local protein synthesis is suggested both by the existence of all components of the translational machinery, including ribosomes, and mRNAs in dendrites. At present it is unclear if local protein synthesis in neurons plays a functional role during development. To address this question we started to investigate the developmental expression and subcellular localization of different components of the translational machinery in dendrites. In a concomitant approach newly synthesized proteins of synaptosomes, prepared from primary hippocampal cultures as well as of synaptoneurosomes (SNS) isolated from dissected rat brains are analyzed at different developmental stages. For these biochemical analyses of *de novo* synthesized proteomes we use the recently developed BONCAT (bioorthogonal non-canonical amino acid tagging) technology, followed by affinity purification and two-dimensional mass spectrometry. Thereby identified proteomes provide a comprehensive picture about the temporal and spatial characteristics of newly synthesized proteomes in both sub-cellular biochemical fractions. Comparative analysis between proteomes obtained from synaptosomes of primary hippocampal cultures and from the analysis of translation active SNS fractions supports the idea that local new synthesis plays already a role during development and is crucial for proper synapse function. The identified proteomes include members of diverse synaptic protein families, like scaffolding molecules, adhesion molecules, pre- and postsynaptic proteins, metabotropic and ionotropic receptors, synaptic vesicle proteins, components of both the protein synthesis and degradation machinery, signalling molecules as well as cytoskeletal proteins. Moreover, identified proteins are present in a wide range of to relevant molecular networks, including those for nervous system development and function, cell morphology, cellular assembly and organization. Our results clearly indicate that local protein synthesis in neurons is not restricted to late developmental stages, but also participates in complex changes of proteomes during early brain development.

Support provided by: DFG (Emmy-Noether Grant, DIP Grant to DCD)

A Precise Temporal Coherency Between Receptor Expression, Neuronal Activity, and AP-1 Dependent Transcription Regulates Dendrite Development in an Identified *Drosophila* Motoneuron

Carsten Duch

¹University Of Mainz, Neurobiology, Col.-Kleinmann-Weg 2 (SBII), 55099 Mainz, Germany

Neural activity has profound effects on the development of dendritic structure. Mechanisms that link neural activity to nuclear gene expression include activity regulated factors such as CREB, Crest, or Mef2 as well as activity regulated immediate early genes, such as fos and jun. This study investigates the role of the transcriptional regulator AP -1, a Fos/Jun heterodimer, in activity-dependent dendritic structure development. We combine genetic manipulation, imaging, and quantitative dendritic architecture analysis in a *Drosophila* single neuron model, the individually identified motoneuron MN5. First, Da7 nAChRs and AP-1 are required for normal MN5 dendritic growth. Second, AP -1 functions downstream of activity during MN5 dendritic growth. Third, using a newly engineered AP -1 reporter we demonstrate that AP-1 transcriptional activity is downstream of Da7 nAChRs and CaMKII signaling. Fourth, AP-1 can have opposite effects on dendritic development, dependent on the timing of activation. Enhancing excitability or AP-1 activity after MN5 cholinergic synapses and primary dendrites have formed causes dendritic branching, whereas premature AP-1 expression or induced activity prior to excitatory synapse formation disrupts dendritic growth. Finally, AP-1 transcriptional activity and dendritic growth are affected by MN5 firing only during development but not in the adult. Our results highlight the importance of developmental timing in the growth and plasticity of neuronal dendrites by defining a development period of activity-dependent AP-1 induction that is temporally locked to cholinergic synapse formation and dendritic refinement, thus significantly refining prior models derived from chronic expression studies.

Dynamic maturation of the axon initial segment in the rodent visual system

Annika Gutzmann, Nursah Ergül^{1,2}, Christian Schultz^{1,2}, Petra Wahle³, Maren Engelhardt^{1,2,3}

¹Medical Faculty Mannheim, Heidelberg University, Institute of Neuroanatomy, CBTM, Mannheim, Germany

²Interdisciplinary Center for Neuroscience, IZN, Heidelberg University, Germany

³Developmental Neurobiology, Faculty of Biology, Ruhr-University Bochum, Germany

Cortical neurons undergo a period of molecular plasticity, during which they can express neuroactive substances that are later downregulated. This phenotype specification is determined by epigenetic factors (e.g. electrical activity) as well as neurotrophins and other endogenous growth factors. Previous studies have demonstrated that the neurochemical phenotype and soma size of neurons in the visual system remains plastic during early postnatal development. One fundamental neuronal cellular microdomain that has so far not been studied in this regard is the axon initial segment (AIS), which spans the proximal part of the axon and is the site of action potential generation. Recent studies shed light on the molecular structure of the AIS, its development as well as its fundamental roles in neuronal function, showing that the AIS is dynamically regulated by e.g. electrical activity. We therefore hypothesized that the AIS shows equally dynamic regulation during development and maturation of visual system neurons. First, we analyzed normal AIS development in the murine visual cortex from embryonic day 14 to late adulthood. Brains were processed for immunofluorescence labeling with ankyrin-G, a key molecule for development and maintenance of the AIS as well as neuronal polarity. AIS length was determined in confocal z-stacks. AIS appeared as early as E14 and increased in length over the early postnatal period with a peak at P15. Then, a continuous shortening of the AIS in cortical layers II/III and V was observed, suggesting a dynamic maturation period. To determine whether neuronal activity is required for normal AIS maturation, we abolished electrical input by visual deprivation (same age groups housed in darkness for one week). Interestingly, now the previous P15 peak in AIS length was even greater than in control groups, indicating to a possible over-compensatory mechanism during AIS development when activity is depleted. In adult animals, visual deprivation did not result in significantly altered AIS length.

Next, we focused on the role of brain derived neurotrophic factor (BDNF) on AIS length during the critical period. Previous studies showed that BDNF increases electrical activity and accelerates dendritic growth. Furthermore, it was shown that when applied via osmotic mini-pumps into the visual cortex of P20-28 rats, BDNF evokes growth of pyramidal neurons in layers II/III and V. We analyzed AIS length in BDNF-infused and control animals as outlined above. Strikingly, when comparing AIS length in ipsilateral vs. contralateral hemispheres, we observed significantly longer AIS under BDNF infusion. The same was seen when comparing BDNF-infused samples with controls. We therefore conclude that BDNF potentially serves to maintain a longer critical AIS maturation period. This corresponds to our observations regarding the onset of a later AIS maturation under sensory deprivation in mice. Our study demonstrates that neuronal activity can influence the size of the AIS and hence possibly alter cellular excitability *in vivo*.

NOMA-GAP CONTROLS DENDRITIC DEVELOPMENT OF NEOCORTICAL NEURONS BY REGULATING CDC42 AND COFILIN

Marta Rosário, Steffen Schuster¹, René Jüttner², Srinivas Parthasarathy¹, Victor Tarabykin¹, Walter Birchmeier²

¹Charite Universitätsmedizin Berlin, Institute of Cell and Neurobiology, Phillipstr 12, 10115 Berlin, Germany

²Max Delbrück Center for Molecular Medicine, Robert Rössle-Str. 10
13092 Berlin

Cortical pyramidal neurons have characteristic well-defined dendritic trees, which are thought to be essential for their function. Indeed, defects in dendritic arborization are associated with human neurological disorders in particular with mental retardation. However, the molecular mechanisms that specify dendritic branching patterns have been poorly studied. We show, using genetically modified mice, in utero electroporation and primary cortical cultures that initiation of dendritic development of cortical neurons requires inactivation of the Cdc42 signaling pathway. Furthermore, we show that the novel signalling molecule, NOMA-GAP, is a critical and necessary mediator of Cdc42 inactivation during cortical development. Loss of NOMA-GAP, results in aberrant activation of Cdc42 during cortical development. We show using in vivo rescue experiments that Cdc42 hyperactivation directly leads to a reduction in dendritic complexity and of cortical volume. In addition, we show that these defects result, at least in part, from the inappropriate downstream inactivation of the actin polymerization regulator cofilin, thus showing for the first time that cofilin activity is required for dendritic arborization during cortical development. We propose that expression of NOMA-GAP in postmitotic cells induces a switch in signalling that permits cofilin activation and extensive dendritic arborisation.

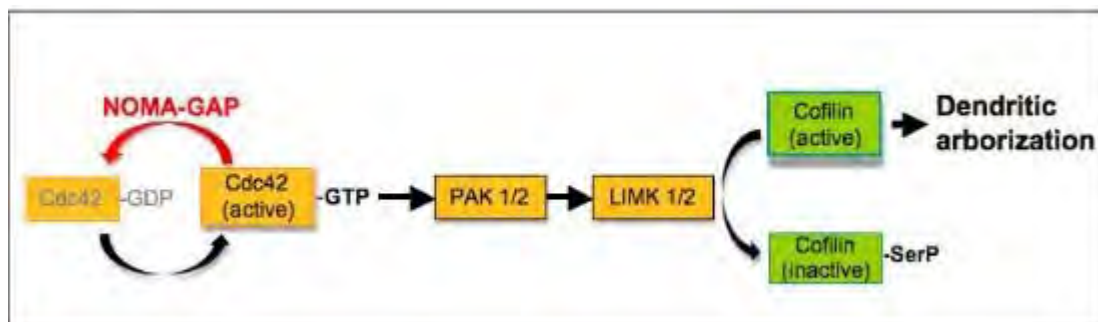

A Co-Culture of Chicken Cochlear Ganglion and Auditory Brainstem Neurons to Investigate Regulation of Endbulb Synapse Formation in Vitro

David Goyer, Stefanie Kurth¹, Kai-Oliver Seibel¹, Hermann Wagner¹, Thomas Kuenzel¹

¹RWTH Aachen University, Institute for Biology 2, Zoology/Animal Physiology, Lukasstraße 1, 52070 Aachen, Germany

In birds, the axons of cochlear ganglion neurons project into two subdivisions of the cochlear nucleus in the auditory brainstem, the nucleus magnocellularis and the nucleus angularis. Only in nucleus magnocellularis specialized axosomatic synapses, the Endbulbs of Held, are formed. These terminals are strongly enlarged, sometimes engulfing nearly three quarters of the postsynaptic cell. The molecular basis for the determination of this giant synapse during development is still largely unknown. To address this, we established a co-culture system of cochlear ganglion (CG) and auditory brainstem neurons of the embryonic chicken.

One cell culture well was divided by an upright glass coverslip with a thickness of 130µm, creating 2 separate compartments. In one compartment auditory brainstem neurons of embryonic day 7 were seeded out. Three days later, CG neurons of embryonic day 10 were explanted into the second compartment. The coverslip was lifted after the cells had settled to allow neurite growth between compartments. Neurons were characterized via immunocytochemical staining against neurofilament and synaptic vesicle protein 2 (SV-2) at various days in vitro. SV-2 puncta size for both neuron types was measured and the CG's neurite outgrowth onto auditory brainstem neurons was characterized.

Staining against neurofilament revealed a distinct bipolar morphology of the CG neurons and a strong axon growth, reminiscent of the in vivo situation. If there were brainstem neurons present, the CG neurons showed a profound axon outgrowth into the brainstem neurons' compartment, indicating that brainstem neurons may emit growth cues that attract CG neurons. We also could demonstrate the existence of SV-2 in the CG neurons' axon terminals, showing that these neurons already express and transport the machinery for synapse formation as early as E10. SV-2 puncta of CG neurons appeared to be larger than those of auditory brainstem neurons and even larger when axons of CG neurons are in vicinity of auditory brainstem neurons. Our results indicate that in vitro innervation of brainstem neurons by CG neurons is possible. The differential SV-2 puncta size shows that this co-culture system is a promising tool for further investigation of molecular aspects of Endbulb-formation and developmental control of synaptic terminal size.

A mechanical coupling between N-cadherin adhesion and F-actin flow stabilizes dendritic spines

Olivier Thoumine, Anael Chazeau¹, Mikael Garcia¹, Katalin Czondor¹, Amelie Argento², Gregory Giannone¹

¹CNRS - University of Bordeaux, Interdisciplinary Institute for Neuroscience, 146 rue Léo saignat, 33077 Bordeaux, France

² CYTOO SA, Minatec, Grenoble

The morphology of neuronal dendritic spines is regulated by both the actin/myosin cytoskeleton and N-cadherin adhesions, but how these components mechanically interact remains unclear. We hypothesized that engagement of a molecular clutch between trans-synaptic N-cadherin adhesions and the actin flow could underlay the stabilization of dendritic filopodia into mature spines. Dendritic spine motility, as measured by live imaging of actin-GFP in primary hippocampal neurons, was increased by expression of non-adhesive N-cadherin constructs. Furthermore, the rearward motion of F-actin structures upon pharmacological stimulation of myosin, and that of N-cadherin coated beads manipulated by optical tweezers, revealed a mechanical coupling between N-cadherin adhesions at the spine tip and the contractile actin/myosin network. Finally, stimulation of dendritic filopodia by N-cadherin coated beads or micropatterns induced the formation of stable spine-like structures enriched in F-actin. These data show that the connection between N-cadherin adhesions and the actin/myosin network stabilizes dendritic spines, a mechanism which may have important implications in synaptic development and plasticity.

Impairment of neurite outgrowth in NGF-stimulated PC12 cells by antibodies directed to *Neisseria gonorrhoeae*, can be reversed by neuroleptic drugs *in vitro*

Bernhard Reuss

¹University of Göttingen, Anatomy - Neuroanatomy, Kreuzberggring 36, 37075 Göttingen, Germany

Prenatal maternal infections with the Gram-negative bacterium *Neisseria gonorrhoeae* (NG) have been correlated to an increased risk for the offspring to suffer from psychotic disorder in later life ¹. Here I tested the effects of a commercially available polyclonal antiserum from rabbit directed to *Neisseria gonorrhoeae* (aNG) on neurite outgrowth in neuronally differentiating PC12 cells stimulated by nerve growth factor. Incubation of differentiating PC12 cells with 10µg/ml of aNG leads to a significant reduction in neurite outgrowth as compared to vehicle treated control cultures. In contrast the same amount of a polyclonal antiserum directed to *Neisseria meningitidis* has no such effect. Surprisingly, reduction in neurite outgrowth by aNG treatment can be reversed by parallel application of the typical antipsychotic drug Haloperidol (0,1µmol/l), or the atypical neuroleptic drugs Clozapine (0,1µmol/l), Olanzapine (10µmol/l) and Risperidone (1µmol/l). In contrast, neurites of terminally differentiated PC12-derived neuron like cells, are not affected by treatment with 10µg/ml of aNG. These results suggest that crossreactivity of bacteria-specific antibodies with neuronal antigens is able to impair neurite outgrowth *in vitro*, and that this impairment can be overcome by treatment with neuroleptic drugs.

¹ Sørensen et al., 2009, Schizophrenia Bull. 35, 631-637

Egr2::Cre mediated conditional ablation of Dicer disrupts histogenesis of mammalian central auditory nuclei

Elena Rosengauer, Heiner Hartwich¹, Anna Maria Hartmann¹, Anya Rudnicki², Somisetty Venkata Satheesh¹, Karen B. Avraham², Hans Gerd Nothwang^{1,3}

¹Carl von Ossietzky Universität Oldenburg, Department of Neurogenetics, Carl von Ossietzky Str. 9-11, 26129 Oldenburg, Germany;

²Sackler Faculty of Medicine, Tel Aviv University, Department of Human Molecular Genetics and Biochemistry, Tel Aviv 69978, Israel;

³Center for Neuroscience, Carl von Ossietzky University Oldenburg, 26111 Oldenburg, Germany.

Histogenesis of the auditory system requires extensive molecular orchestration. Recently, Dicer1, an essential gene for generation of microRNAs, and the microRNA miR-96 were shown to be important for development of the peripheral auditory system. Here, we investigated their role for the formation of the auditory brainstem. Egr2::Cre mediated early embryonic ablation of Dicer1, an essential gene for generation of miRNAs, caused severe disruption of auditory brainstem structures. In adult animals, the volume of the cochlear nucleus complex (CNC) was reduced by 73.5%. This decrease is in part attributed to the lack of the microneuronal shell. In contrast, fusiform cells, which similar to the granular cells of the microneuronal shell, are derived from Egr2 positive cells, were still present. The volume reduction of the CNC was already present at birth (67.2% decrease). The superior olivary complex was also drastically affected in these mice. Nissl staining as well as Vglut1 and Calbindin 1 immunolabeling revealed that principal SOC nuclei such as the medial nucleus of the trapezoid body and the lateral superior olive were absent. Only choline acetyltransferase positive neurons of the olivocochlear bundle were observed as a densely packed cell group in the ventrolateral area of the SOC. Mid-embryonic ablation of Dicer1 in the ventral cochlear nucleus by Atoh7::Cre -mediated recombination resulted in normal formation of the cochlear nucleus complex, revealing an early embryonic requirement of Dicer1. Quantitative RT-PCR analysis of miR-96 demonstrated low expression in the embryonic brainstem and up-regulation thereafter, suggesting that other microRNAs are required for proper histogenesis of the auditory brainstem. Together our data identify a critical window of Dicer activity during early development of the auditory brainstem and raise interesting perspectives as to the evolution of the auditory brainstem.

Poster Topic

T3: Developmental Cell Death, Regeneration and Transplantation

- T3-1A** Quantification of olfactory afferent regeneration in the locust brain
Hannah Wasser, Michael Stern
- T3-2A** Three-dimensional constructs of electrospun PCL-fibers in collagen gel as guidance structure for nerve regeneration
Andreas Kriebel, Muhammad Rumman, Miriam Scheld, Dorothee Hodde, Gary Brook, Jörg Mey
- T3-1B** An IP3R3- and NPY-expressing microvillous cell mediates tissue homeostasis and regeneration
Colleen Cosgrove Hegg, Cuihong Jia, Sebastien Hayoz, Chelsea Hutch, Tania Iqbal
- T3-2B** Molecular Mechanisms of Unconventional Secretion of Insulin-Degrading Enzyme
Marie Löchner, Olaf Merkel, Jochen Walter, Konstantin Glebov
- T3-3B** Deoxyribozyme to Xylosyltransferase-1 mRNA Promotes Functional Recovery after Spinal Cord Contusion
Barbara Grimpe, Owen Y. Chao, Donna L. Avison, Roderick T. Bronson, William J. Buchser, Andres Hurtado, Martin Oudega
- T3-1C** Effects of AAV-based gene therapy on axonal regeneration and motorical behaviour in a rat model of rubrospinal tract injury
Malleswari Challagundla, Thomas Ostendorf, Sebastian Kügler, Jan Christoph Koch, Uwe Michel, Mathias Bähr, Paul Lingor
- T3-2C** How the way of extirpation affects brain regeneration in the earthworm *Eisenia fetida*
László Molnár, Bálint Horváth, Anita Steib, Edit Pollák
- T3-3C** Neuronal regeneration in the midleg of *Schistocerca gregaria*
Alexander Schnurr, Reinhard Lakes-Harlan
- T3-1D** Morphological, physiological and neurochemical background of the ventral nerve cord regeneration in *Eisenia fetida*
Dóra Gunszt, Eszter Várhalmi, Ildikó Somogyi, Edit Pollák, Péter Engelmann, László Molnár
- T3-2D** Transplantation of neurons from the embryonal ganglionic eminences into matured mouse cortex
Marcel Isstas, Manuel Teichert, Jürgen Bolz, Konrad Lehmann

Quantification of olfactory afferent regeneration in the locust brain

Hannah Wasser, Michael Stern¹

¹University of Veterinary Medicine Hannover, Cell Biology, Bischofsholer Damm 15/102, 30173 Hannover, Germany

We study neuronal regeneration in the olfactory pathway of the locust (*Locusta migratoria*). Olfactory afferents are axotomized in adult locusts and 5th instar nymphs by crushing the base of one antenna, leaving the other antenna as an internal reference. We quantify the resulting degeneration and subsequent regeneration in the first olfactory processing center, the antennal lobe, by means of anatomical size measurements, quantitative immunofluorescence of cell surface markers, anterograde labeling, and intracellular recording.

In the antennal lobe of postembryonic locusts, the cell adhesion molecule Fasciclin I is exclusively expressed by olfactory receptor neurons. Thus, after degeneration of axotomized distal segments of sensory neurons, Fasciclin I staining vanished in the antennal lobe within two days following the deafferentation. The reappearance of Fasciclin I during the following days proved a valuable quantitative marker for the regeneration process. Olfactory receptor neurons of 5th instar nymphs regenerated faster than those of adults.

To describe the neuroanatomical changes during regeneration the ingrowing afferents were labeled anterogradely with neurobiotin through the scraped-off olfactory sensilla on individual antennal segments (annuli). Normally, fibers from individual annuli grow together as discrete bundles in the antennal nerve and innervate the antennal lobe in a conspicuous ring-shaped pattern. Such an ordered pattern of growth and innervation is not observed in regenerated fibers, despite their precise confinement to the antennal lobe.

Intracellular recording from olfactory interneurons in the antennal lobe revealed the first regenerated synaptic connections seven days after axotomy.

Three-dimensional constructs of electrospun PCL-fibers in collagen gel as guidance structure for nerve regeneration

Andreas Kriebel, Muhammad Rumman¹, Miriam Scheld¹, Dorothee Hodde², Gary Brook², Jörg Mey^{3,4}

¹Institute of Biology II, Department of Zoology and Animal Physiology, RWTH Aachen, Germany

²Institute of Neuropathology, UK Aachen, Germany

³Hospital Nacional de Paraplégicos, Toledo, Spain

⁴EURON Graduate School of Neuroscience, Maastricht, Netherlands

Introduction: In contrast to the CNS, where regeneration after injury is largely prevented by inhibitory molecules in myelin and the formation of a glial scar, the PNS has the inherent ability to regenerate after injury. The functional outcome of this regeneration process is strongly dependent on the severity of the preceding trauma and often has to be supported by a surgical intervention, like the suturation of the incidental nerve stumps or the inset of an autologous nerve graft. If the latter is not available, artificial implants have to be used. These are generally inferior to an autograft, because they lack guidance cues for Schwann cells and regenerating axons. To overcome this drawback different kinds of structures are investigated for their ability to serve as a guidance cue for axons and Schwann cells. We have shown that electrospun microfibers of poly-caprolactone (PCL) are able to guide Schwann cells and axons (Schnell et al., Biomaterials 2007) and offer the possibility to be functionalized with extracellular matrix (ECM) derived peptides (Bockelmann et al., Tiss. Eng. A, 2011). The goal of this project is the development of a three-dimensional guidance structure as a peripheral nerve implant. **Objectives:** Production and biological testing of three-dimensional arrays of electrospun PCL fibers. **Results:** We developed a novel way of electrospinning a three dimensional array of aligned PCL microfibers which were embedded into a collagen matrix. Since the dimensionality of substrates can influence cell morphology we addressed the question whether results gathered with 2D *in vitro* experiments could be reproduced within a 3D substrate. Using cultures of embryonic chicken dorsal root ganglia (DRG) in our composite scaffold we have established that PCL-microfibers dictate the direction of Schwann cell migration and axonal growth in the 3D matrix. This scaffold was then incorporated into biodegradable PCL -tubes that can be implanted as nerve bridges *in vivo*. **Conclusion:** With the achievement of a biologically useful 3D fiber array the present results represent an important step towards the goal of constructing an artificial implant for peripheral nerve repair strategies.

An IP3R3- and NPY-expressing microvillous cell mediates tissue homeostasis and regeneration

Colleen Cosgrove Hegg, Cuihong Jia¹, Sebastien Hayoz¹, Chelsea Hutch¹, Tania Iqbal¹

¹Michigan State University, Pharmacology and Toxicology, 1355 Bogue St, 48824 East Lansing, USA

Calcium-dependent release of neurotrophic factors plays an important role in the maintenance of neurons, yet the release mechanisms are understudied. The IP3 receptor is a calcium release channel that has a physiological role in cell growth, development, sensory perception, neuronal signaling and secretion. In the olfactory system, the IP3 receptor subtype 3 is expressed exclusively in a subtype of microvillous cell that is the predominant cell that expresses neurotrophic factor NPY. We hypothesized that this subset of IP3R3-expressing microvillous cells secretes the NPY needed for both the continual maintenance of the neuronal population and for neuroregeneration following injury. We addressed this question by assessing the release of neurotrophic factor NPY, olfaction behavior, and regenerative capabilities in wild type mice, IP3R3^{+/-} and IP3R3^{-/-} mice. Here, we provide evidence that the IP3 receptor mediates NPY release following injury simulation and that NPY release is impaired in IP3R3^{-/-} mice, suggesting that IP3R3 contributes to NPY release upon injury. IP3R3^{-/-} mice exhibit a 59% decrease in the number of progenitor cells and a 57% decrease in immature neurons ($p < 0.001$, unpaired Student's t-test). However, the number of mature neurons and the rate of proliferation are not altered ($p > 0.4$, unpaired Student's t-test). In addition, the proliferative response to injury is compromised in the olfactory epithelium of IP3R3^{-/-} mice (25% reduction in BrdU incorporation, $p < 0.02$, unpaired Student's t-test). These data suggest that the reductions in both NPY release and number of progenitor cells have functional consequences. Finally, IP3R3^{-/-} mice have altered olfactory behavior in the habituation-dishabituation assay. Collectively, these data suggest that IP3R3 may play a role in processing of sensory information by the olfactory system, and that IP3R3 expressing microvillous cells are actively responsive to injury and promote recovery.

Molecular Mechanisms of Unconventional Secretion of Insulin-Degrading Enzyme

Marie Löchner, Olaf Merkel¹, Jochen Walter¹, Konstantin Glebov¹

¹University of Bonn, Department of Neurology, Sigmund-Freud-Str. 25, 53127 Bonn, Germany

Deposition of amyloid- β (A β) plaques in the brain, the hallmark of Alzheimer's disease (AD), is attributed to an accumulation of A β that is based on an imbalance between production and clearance of A β . The Zn²⁺-dependent M16 metalloprotease insulin-degrading enzyme (IDE) is strongly involved in proteolytic degradation of monomeric A β and other substrates like insulin and endorphin. It is ubiquitously expressed and shows a cytosolic, nuclear and membrane-bound localization, and can be also found in extracellular fluids. The IDE-mediated hydrolysis of A β can occur extracellularly, but little is known about the detailed mechanisms of IDE secretion. Recent studies demonstrated that IDE could be released from microglia cells via the unconventional exosome-associated secretory pathway^{1,2}. Neuron-glia interaction in the brain plays an essential role for various processes from neuronal development and synaptic plasticity to glial activation. Among neurochemical signals that may have influence on microglia function we identified that 5-hydroxytryptamine (serotonin or 5-HT) can trigger the secretion of IDE from microglial cells. Application of 5-HT increased IDE release from BV-2 microglia cells. Gene expression analysis of 5-HT receptors (5-HTRs) in BV-2 cells demonstrated the presence of 5-HT_{2a}, 2b, 3a and 4 receptors. To examine the downstream signalling cascades that are responsible for the secretion of IDE we analysed how specific modulation of particular 5-HTRs and corresponding downstream effectors may affect the unconventional release of IDE; for confirmation of our pharmacological findings we utilised a siRNA gene silencing approach. Here we demonstrate that the activation of the 5-HT_{2a} and b receptors and their well-characterised PLC-dependent Ca²⁺ pathway is responsible for IDE release. To our surprise, 5-HT₄R-dependent increase in cAMP levels can also promote the PLC-mediated release of IDE. We show that 5-HT₄R-mediated PLC activation is caused by activation of Rap1 that is in turn activated by cAMP-GEF1/2 (Epac1/2). Co-culture experiments with mouse primary neurons and microglial cells indicated that neurons might influence IDE secretion from microglia. To further understand the mechanism of unconventional IDE release we are using yeast two-hybrid system to identify interaction partners of IDE that could be involved in IDE trafficking and secretion.

(¹ Bulloj *et al.* J Alzheimers Dis 2010 19(1): 79-95, ² Tamboli *et al.* J. Biol. Chem. 2010 285(48):37405-14)

Deoxyribozyme to Xylosyltransferase-1 mRNA Promotes Functional Recovery after Spinal Cord Contusion

Barbara Grimpe, Owen Y. Chao², Donna L. Avison³, Roderick T. Bronson⁴, William J. Buchser⁵, Andres Hurtado⁶, Martin Oudega⁷

¹Department of Neurology, Heinrich Heine University, Düsseldorf, 40225, Germany; ²Department of Experimental Psychology, Heinrich Heine University, Düsseldorf, 40225, Germany; ³Department of Surgery, Leonard M. Miller School of Medicine, University of Miami, Miami, FL, 33136, USA; ⁴Dana-Faber/Harvard Cancer Center, Boston, MA, 02115, USA; ⁵Department of Surgery, University of Pittsburgh School of Medicine, Pittsburgh, PA, 15213, USA; ⁶International Center for Spinal Cord Injury, Hugo W. Moser Research Institute at Kennedy Krieger, and Department of Neurology, Johns Hopkins University School of Medicine, Baltimore, MD, 21205, USA; ⁷Departments of Physical Medicine and Rehabilitation, Neurobiology, and Bioengineering, University of Pittsburgh School of Medicine, Pittsburgh, PA, 15213, USA.

Spinal cord injury (SCI) causes immediate motor and sensory function impairments and life-threatening secondary reactions. Therapeutics to treat SCIs are preferably easy to manufacture with flexibility in their targets and easy to administer with relative short half-lives. Deoxyribozymes (or DNA enzymes) fulfill these criteria. They are single-strand DNA molecules with a catalytic loop structure and sequence-specific binding arms that bind and digest targeted mRNA. After SCI, upregulation of growth-inhibitory proteoglycans within glial scar tissue surrounding the injury epicenter limits spontaneous axonal growth. Preventing or limiting proteoglycan upregulation may facilitate axonal sprouting/regeneration and thus plasticity after SCI. The formation of the growth-inhibitory glycosaminoglycan side chains (i.e., glycosylation) of proteoglycans is initiated by xylosyltransferase (XT).

In the present study, we investigated whether treatment with a deoxyribozyme to XT-1 mRNA (DNAXT-1as) would elicit an axonal response and functional recovery after SCI. DNAXT-1as was delivered intravenously, a clinically relevant non-invasive mode of administration. The effects of DNAXT-1as were assessed in a rat model of spinal cord contusion which is the most frequent mechanism of SCI in humans and thus clinically highly relevant. Our results demonstrate that intravenous DNAXT-1as administration significantly enhanced serotonergic axon sprouting/regeneration and functional restoration after spinal cord contusion. DNAXT-1as treatment did not aggravate neuropathic pain beyond what is normally observed after contusive SCI. Importantly, intravenous DNAXT-1as administration did not result in toxicological or pathological side-effects.

We argue that systemic administration of DNAXT-1as is a safe and effective approach to facilitate axonal and functional plasticity after contusive SCI. Our data support the inclusion of DNAXT-1as treatment in future therapies for SCI.

Support was provided by the Department of Physical Medicine and Rehabilitation at the University of Pittsburgh (MO); the German Research Foundation (DFG, BG); Forschungskommission of the HHU (BG); Ralph. Wilson Medical Research Foundation (BG); Buoniconti Fund (BG); and the Florida State Fund (BG).

Effects of AAV-based gene therapy on axonal regeneration and motorical behaviour in a rat model of rubrospinal tract injury

Malleswari Challagundla, Thomas Ostendorf¹, Sebastian Kügler¹, Jan Christoph Koch¹, Uwe Michel¹, Mathias Bähr¹, Paul Lingor¹

¹University medicine Göttingen, Neurology, waldweg-33, 37073 Göttingen, Germany

²GGNB doctoral program, "Center for Molecular Physiology of the Brain" (CMPB)

The rat rubrospinal tract lesion is a model for traumatic spinal cord lesion and results in atrophy of the red nucleus neurons and axonal dieback. In this study we evaluated the effects of AAV-based gene therapy on axonal regeneration, sprouting, axonal dieback and motorical behaviour after rubrospinal tract injury. We targeted the expression of GFP-tagged BAG1, miRNA-134 and sh.ROCK2, Reggie1 using AAV2/1-vectors to the red nucleus in order to trace and treat the rubrospinal tract after unilateral dorsal quadrant hemisection at T9.

Animals were followed up to 12 weeks after the lesion with various behavioural tests, such as BBB, horizontal ladder rung test and a CatWalk analysis. Spinal cords were then removed and prepared for an immunohistochemical analysis. We here present the quantification of the regeneration response at the lesion site and the collateral sprouting of rubrospinal tract axons on to the gray matter, which was observed at various levels of the spinal cord proximal to the lesion site. The data of the motorical analysis is correlated with the histological quantification.

How the way of extirpation affects brain regeneration in the earthworm *Eisenia fetida*

László Molnár, Bálint Horváth², Anita Steib¹, Edit Pollák¹

¹ University of Pécs, Department of General Zoology, Ifjúság u. 6., H-7624 Pécs, Hungary

²Department of Pathology, University of Pécs, Ifjúság u. 6. H-7624 Pécs, Hungary

The regeneration of the cerebral ganglion (so-called brain) was investigated in the earthworm *Eisenia fetida* applying two absolutely different extirpation methods, respectively. In the first group of animals both of the circumpharyngeal connectives (CCs) were transected with sharp steel blade, in the second group the left CC was transected and the right one was cauterized by glowing tungsten wire on the level of the second segmental nerves. During regeneration the concentration gradient of a known neuroprotective neuropeptide, pituitary adenylate cyclase-activating peptide (PACAP), along the central nervous system and the pattern of the characteristic GABAergic landmark structures were investigated.

Following brain extirpation a marked increase of PACAP synthesis was determined by radioimmunoassay in the ventral nerve cord ganglia. However, a decreasing gradient of PACAP from the subesophageal ganglion (SG) to cross-cut CC was found in regenerating earthworms while in the cauterized CC the PACAP concentration was significantly higher than in the SG suggesting that neural processes transport PACAP and other neuropeptides, transmitters etc. to the site of regeneration. By means of immunocytochemistry high number of PAC1-receptor expressing cells were found in the regenerating blastema developed close to the cross-cut surface of the CCs. Most of them proved to be stem cells (neoblasts) of earthworms.

When both circumpharyngeal connectives (CCs) were intersected prior to brain ablation the renewed brain became identical, both in size and GABA labelling, with the extirpated one on the third week of the regeneration. If one of the CCs was cut through and the other one cauterized during the brain extirpation, an absolutely asymmetric brain regenerated: neither its size and shape nor GABA labelling were identical with the excised ganglion. At the cross-cut side approximately a hemiganglion of normal size while at the cauterized side a significantly smaller one regenerated. In the former one the number and pattern of GABAergic landmark structures were the same as were seen in ablated hemiganglion while in the latter one the reduction of landmark structures, both in the number and position, was observed. In the cauterized CC neither GABA immunoreactive neurons nor migrating undifferentiated cells were found. However, its diameter often increased up to twofold of the original size because of the axon swelling as the consequence of the blocked axonal transport. These findings strongly suggest that the dedifferentiation of neurons and their migration along the ventral nerve cord pathways do not contribute to the brain regeneration. In contrast the elaboration of neuroactive substances (transmitters, neurohormones like PACAP, growth factors) from the central nervous system via the CCs could mediate the migration and attachment of earthworm stem cells (neoblasts) to the cut surface of CC and could mediate their differentiation to neuronal, glial, muscular and connective tissue cells resulting the formation of a new brain and its capsule. This hypothesis is supported by the results of pharmacological experiments, namely injection of PACAP-antagonist to the site of regeneration strongly inhibited differentiation of neural somata and growing of processes so the structure of the regenerated cerebral ganglion was significantly less organized than the original brain was.

Neuronal regeneration in the midleg of *Schistocerca gregaria*

Alexander Schnurr, Reinhard Lakes-Harlan¹

¹Justus-Liebig-Universität Gießen, Integrative Sinnesphysiologie, Heinrich-Buff-Ring 38, 35392 Gießen, Germany

The leg nerves of *Schistocerca gregaria* innervate the leg muscles and the various peripheral sensory organs. The cell bodies of the motoneurons are located in the CNS, whereas those of the sensory neurons are located in the periphery. Thus, an axotomy of a leg nerve might trigger different processes in distal and proximal direction. Since the neuronal environment is the same, such lesions will also indicate possible differences in the regeneration capacities of motoneurons and sensory neurons.

All experiments were performed with adult *Schistocerca gregaria* of both sexes. For the operation one leg nerve was crushed at distinct sites in the leg. After a post crushing period, neuronal tracing was done with either Cobalt chloride or Neurobiotin. The results show that the motoneurons seem not to regenerate lesioned axons. A lesion always impaired the movement of the leg, although the movability improved with time. A functional regeneration could not be shown by electrical stimulation.

Sensory axons, by contrast, regenerate their lesioned axons quite well. One of the sensory systems on a leg are trichoid hair sensilla, tested at the distal femur. Each of these sensilla is innervated by one sensory neuron whose axon runs within the nerve 5B1. It could be shown that hair sensilla of the distal femur regenerate a central projection in the mesothoracic ganglion ten days after crushing the nerve 5B1. The regenerated central projections are enlarged in comparison to non-operated animals. This enlargement is due to extensions in anterior-posterior and medial-lateral direction and is maintained at least to day 25 after the operation (end of observation). Furthermore, it could be shown that the femoral chordotonal organ (feCO) regenerates its axonal projections. However, the regenerated projections change their morphology from the first stages of regeneration (10 days after crushing) to 20 days after crushing. Only in the later stages the regenerated projection is similar to the control situation, indicating a refinement of projection. Immunohistochemical analyses show an enhanced expression of the cell surface molecule Fasciclin I in both scoloparia of the feCO. The enhanced expression was present in all investigated stages of regeneration. The results suggest the large neuronal regeneration potential of sensory axons and open the field for studies on the mechanisms of regeneration.

Morphological, physiological and neurochemical background of the ventral nerve cord regeneration in *Eisenia fetida*

Dóra Gunszt, Eszter Várhalmi¹, Ildikó Somogyi¹, Edit Pollák¹, Péter Engelmann²,
László Molnár¹

¹University of Pécs, Department of General Zoology and ² Immunology and Biotechnology, Pécs, Hungary

Some earthworm species have enormous capability to renew their lost ventral nerve cord ganglia. In this process, commonly named “neuroregeneration”, certain neural and non-neural structures (e.g. intact parts of the central nervous system, neoblasts, some coelomocytes) and several chemical substances (e.g. hormones, neurotransmitters, growth factors) are believed to be involved.

Applying radioimmunoassay (RIA) the amounts of the neuractive pituitary adenylate cyclase-activating peptide (PACAP) was determined in both intact and regenerating VNC ganglia showing that the concentration of both PACAP27 and PACAP 38 increased during the regeneration. By means of SELDI-TOF Mass Spectrometry the up-regulation of distinct peptide groups, characterized by 1-5 kDa mass intervals, was also shown in regenerating ganglia, suggesting that certain neuropeptides play a key-role in the mediation of the renewing of the extirpated ganglia.

Parallel morphological and histochemical examinations revealed the main steps of the regeneration: (1) inflammatory response in severed segments mediated by coelomocytes; (2) reorganization of nerve processes and perikarya in the injured ganglion; (3) migration and proliferation of blast cells that form regeneration blastema attached to the severed body parts; and (4) differentiation of blast cells to specific tissue cells like neural tissue cells, further development of cell connections between old and newly formed structures.

In the first step certain types of coelomocytes, characterized by high acid phosphatase content and phagocytotic activity, could play key-role because injured tissues were infiltrated with coelomocytes that clear away tissue debris and damaged structures further protect the wound against microbial infections elaborating antimicrobial substances. Next steps conduct the renewing of VNC ganglia that are thought to be absolutely identical with the amputated ones, both in structure and pattern. Focusing on the gross anatomy of the renewing VNC ganglia and the pattern of their GABAergic landmark structures normal and abnormal regenerating processes were identified. If the body was cross-cut at the segment border where connectives of VNC ganglia are situated the anatomy of both renewed segments and their ganglia showed the same characteristics that the removed ones. When the plane of transection crossed the chaetae row, where the neuron rich part of VNC ganglion was identified, seemingly normal segments renewed in which the shape and pattern of most internal structures like dissepiments, midgut and metanephridia showed the same characteristics as in amputated ones except for the first 1-4 regenerated ganglia in which frequently seen various malformations like less or more than three pairs of segmental nerves and, compared to intact ganglia, marked changes in both the number and pattern of GABAergic landmark neural structures. Behind these distorted ganglia all the regenerated ones showed the same characteristics as ablated ganglia/structures.

These findings show that transected VNC mediates normal segment regeneration in all cases; however its normal renewing depends on the site of transection suggesting that growing neural processes as landmark structures and extent of their damage have strong influence on genetically and neurochemically determined epimorphic regeneration of earthworms.

Transplantation of neurons from the embryonal ganglionic eminences into matured mouse cortex

Marcel Isstas, Manuel Teichert¹, Jürgen Bolz¹, Konrad Lehmann¹

¹Friedrich-Schiller-Universität Jena, Institut für Allgemeine Zoologie und Tierphysiologie, Erbertstrasse 1, 07743 Jena, Germany

Transplantation into the postnatal brain of a variety of different cell types has been used for experimental and therapeutic purposes in recent years. Neuronal precursors from the medial ganglionic eminence (MGE), which are destined to become GABAergic interneurons, have been shown to be efficient in ameliorating neuropathic pain (Braz et al., 2012) and epileptiform discharges (De la Cruz et al., 2011). If transplanted into the adult neocortex or striatum, cells derived from the MGE, but not the lateral ganglionic eminence (LGE), migrate away from the transplantation site (Wichterle et al. 1999). Moreover, during a well-defined time-window after transplantation, MGE cells trigger an artificial critical period for ocular dominance plasticity in the juvenile mouse brain (Southwell et al. 2010).

We wished to further characterize the migration and development of transplanted neuronal precursors in the mature (> 110 postnatal days) host brain, comparing not only cells derived from MGE and LGE, but also from the preoptic area (POA). Cells were dissected from EGFP+ mouse embryos at day 14 of gestation and transplanted into the occipital cortex of fully adult mice. At different time points after transplantation, the animals were perfused, and the brains were stained immunohistochemically.

As expected, we found that MGE derived cells migrated over several hundred micrometers in the mature brain, whereas cells from the LGE survived, but did not leave the injection site. POA cells were similar to MGE cells in that they dispersed throughout the cortex. Immunohistochemical staining showed that the majority (~ 95%) of transplanted MGE cells were GABAergic, with subpopulations expressing parvalbumin, somatostatin but not VIP. The majority of cells from the POA was likewise GABAergic, and many cells doublestained for VIP.

A new finding was that neurites of MGE derived cells branched extensively and formed clearly layered webs in the cortex. Some axons from cells of all origins travelled over remarkable distances, stretching over several millimeters in the ipsilateral cortex or even crossing the midline to hetero- and homotopic contralateral targets. E.g., after transplantation of LGE cells into the hippocampal hilus, a dense net of axonal terminals was found at the contralateral homotopic location.

Thus, it appears that even the adult and fully mature cortex maintains the guidance cues necessary for GABAergic neuronal precursors to migrate and to target their axons. These findings underscore the potential of neuron transplantation for therapeutic interventions in the mature and ageing brain.

References:

Braz JM, Sharif-Naeini R, Vogt D, Kriegstein A, Alvarez-Buylla A, Rubenstein JL, Basbaum AI. 2012. Forebrain GABAergic neuron precursors integrate into adult spinal cord and reduce injury-induced neuropathic pain. *Neuron* 74(4):663-75

De la Cruz E, Zhao M, Guo L, Ma H, Anderson SA, Schwartz TH. 2011. Interneuron progenitors attenuate the power of acute focal ictal discharges. *Neurotherapeutics* 8(4):763-73

Wichterle H, Garcia-Verdugo JM, Herrera DG, Alvarez-Buylla A. 1999. Young neurons from ganglionic eminence disperse in adult and embryonic brain. *Nat Neurosci.* 2(5):461-6

Southwell DG, Froemke RC, Alvarez-Buylla A, Stryker MP, Gandhi SP. 2010. Cortical plasticity induced

by inhibitory neuron transplantation. Science 327(5969):1145-8

Poster Topic

T4: Neurotransmitters, Retrograde messengers and Cytokines

- T4-1A** Imaging and analysis of serotonin release from stem cell-derived serotonergic neurons.
Thorsten Lau, Verena Proissl, Annabelle Schlüter, Patrick Schloss
- T4-2A** Serotonin inside and outside the cell during pre-nervous stages is essential for correct development and juvenile behavior
Evgeny G. Ivashkin, Igor I. Adameyko, Olga A. Kharchenko, Marina Yu. Khabarova, Elena E. Voronezhskaya
- T4-3A** Monoaminergic interactions with identified interneurons in the basolateral amygdala: comparative investigations in rats, wildtype and serotonin transporter (5Htt)-deficient mice
Christoph Renninger, Henning Schwert, Maria Steinke, Jonas Waider, Angelika Schmitt, Esther Asan
- T4-1B** Identification of donor and target cells of the NO/cGMP pathway in the brain of *Tribolium castaneum*
Björn Trebels, Carsten M. Heuer, Joachim Schachtner
- T4-2B** Nitric oxide/ cGMP -signaling regulates the excitatory/ inhibitory input onto hippocampal CA1 pyramidal cells
Angela Neitz, Thomas Mittmann
- T4-1C** Dissecting the role of serotonin in the feeding behavior of the adult *Drosophila melanogaster*.
Shreyas Venkataraman Jois, Henrike Scholz
- T4-2C** PKG and honey bee behavior
Markus Thamm, Ricarda Scheiner
- T4-1D** INFLUENCE OF THE EXTRACELLULAR MATRIX ON GLUTAMATE UPTAKE
Jose Francisco Alfaro Sanchis, Martin Heine, Artur Bikbaev, Renato Frischknecht
- T4-2D** Endocannabinoid Signalling in the Medial Superior Olive
Barbara Trattner, Sarah Berner, Benedikt Grothe, Lars Kunz
- T4-3D** Descending OA3/TA interneurons of the locust brain
Sergej Hartfil, Dr. Natalia Kononenko, Julia Willer, Prof. Dr. Hans-Joachim Pflüger

Imaging and analysis of serotonin release from stem cell-derived serotonergic neurons.

Thorsten Lau, Verena Proissl¹, Annabelle Schlüter², Patrick Schloss¹

¹Zentralinstitut für Seelische Gesundheit, Medizinische Fakultät Mannheim, Universität Heidelberg, Biochemisches Labor, 68159 Mannheim, Germany

²Zentrum für Biomedizin und Medizintechnik Mannheim (CBTM), Medizinische Fakultät Mannheim, Universität Heidelberg, Neuroanatomie, 68167 Mannheim

Due to their small number in the rodent brain as well as their extensive growth throughout the brain, serotonergic neurons cannot be isolated for primary cell cultures. Therefore, in-vitro systems of either neuronal or embryonic stem cell-derived serotonergic neurons were established to study molecular mechanisms of serotonergic neurotransmission on a cellular level. In the recent years, stem cell-derived serotonergic neurons provided new insights into regulation of serotonergic neurotransmission as well as the role of serotonergic dysfunction in mental diseases. In combination with confocal laser scanning microscopy, these cellular models allow to image and analyze serotonin release from stem cell-derived serotonergic neurons in live cell imaging experiments.

In order to perform such experiments we use two different approaches to monitor and track serotonergic neurotransmitter vesicles. In our first approach we directly label serotonin containing vesicles using either fluorescent ligands or fluorescent substrates of the vesicular monoamine transporter 2. In our second approach we apply the styryl dye FM4-64 which labels serotonin releasing vesicles during exocytotic events. In addition, this staining method also allows an immunofluorescence analysis of serotonergic neurons following live cell imaging experiments. Both methods were used to visualize (1) the stress-induced release of serotonin, and (2) the influence of psychoactive compounds on serotonergic neurotransmission. Here we were able to provide first evidence that dexamethason and nicotine induced exocytotic events in while methanandamide prevented depolarization of stem cell-derived serotonergic neurons.

Serotonin inside and outside the cell during pre-nervous stages is essential for correct development and juveniles behavior

Evgeny G. Ivashkin, Igor I. Adameyko², Olga A. Kharchenko¹, Marina Yu. Khabarova¹,
Elena E. Voronezhskaya¹

¹Institute of Developmental Biology RAS, comparative physiology, Vavilov str., 26, 119991 Moscow, Russia

²Karolinska Institute, Stockholm, Sweden

Recent data demonstrated that the function of neurotransmitters during animal's development does not reflect the existing classical view on neurotransmitters as molecules that just transmit the signal from cell to cell. Serotonin (5-HT) is involved in a variety of regulations based on the equilibrium of the intra- and extracellular 5-HT level. Examples of such regulations are known for different processes in adult mammals. Such equilibrium is provided by functioning of 5-HT system: enzymes of synthesis and degradation, transporters and 5-HT receptors. And the same proteins are known to be expressed at the very early pre-nervous stages. However do similar mechanisms exist in the early development? And if they exist are they conservative? We use models of different aquatic invertebrates and low vertebrates early development to answer this question.

Serotonin (5-HT) is expressed at very early developmental stages in a wide variety of animals and components of 5-HT system are functionally active starting from the oocyte stage up to blastocyst in mammals. We analyzed in detail expression and functional activity of 5-HT system components in aquatic animals (gastropod and bivalve mollusks, sea urchin and teleost fish) during early cleavage stages. We found that 5-HT synthesis and transport are differentially distributed among cells of early developing embryo and larvae. Injected 5-HT is actively transported to the cell membrane and release from the cell. Induced increase in 5-HT level in defined time window during early cleavage may result in irreversible developmental malformation in a concentration-dependent manner or modification in juvenile behavior. This sensitive time window positively correlated with changes in functions of 5-HT transporter. Our investigation demonstrated the functional importance of 5-HT equilibrium during early developmental stages for correct developmental pattern and behavior formation in model invertebrates and low vertebrate animals.

The work was supported by RFBR grants 12-04-90844, 12-04-10119, 12-04-01510.

Monoaminergic interactions with identified interneurons in the basolateral amygdala: comparative investigations in rats, wildtype and serotonin transporter (5Htt)-deficient mice

Christoph Renninger, Henning Schwert¹, Maria Steinke², Jonas Waider³, Angelika Schmitt³, Esther Asan¹

¹University of Würzburg, Institute of Anatomy and Cell Biology, Koellikerstr. 6, 97070 Würzburg, Germany

²University of Würzburg, Department for Tissue Engineering and Regenerative Medicine, Röntgenring 11, 97070 Würzburg

³University of Würzburg, Clinic for Psychiatry, Psychosomatics and Psychotherapy, Molecular Psychiatry, Fuchsleinstr. 15, 97080 Würzburg

The amygdala plays a central role in processing and memory of emotional stimuli. Afferent monoaminergic and intrinsic inhibitory interneuronal systems modulate information processing in the main amygdaloid target areas of telencephalic inputs, the lateral (La) and basolateral (BL) nuclei. Interactions between monoaminergic afferents and parvalbumin (PV) or neuropeptide Y (NPY)-producing interneurons are of particular functional interest. Numerous studies indicated significant inhibitory influence of PV-producing interneurons on output neurons, and strong anxiolytic effects of NPY in the La and BL. Moreover, the number of NPY-producing neurons was negatively correlated with anxiety-like behavior in rats. Immunohistochemical (IHC) and in situ hybridization (ISH) findings documented contacts of serotonergic (5-HT) and dopaminergic fibers with and expression of subtypes of 5-HT receptors in PV- and NPY-producing somata of rat La and BL, confirming interactions between monoaminergic afferents and these interneuron subpopulations.

To provide a basis for assessing the impact of alterations in monoamine homeostasis on amygdaloid circuits in genetic mouse models for emotional dysregulation, the present investigation was designed to extend analyses of monoaminergic innervation and receptor expression, and of PV- and NPY-producing interneuron distribution and density to the mouse La and BL. Additionally, interneuron innervation and density were assessed in 5-Htt deficient mice, which serve as an animal model for depression and anxiety disorders.

ISH using mouse-specific cRNA probes to detect mRNA of 5-HT receptor subtypes 1A, 2C and 3 documented the expression of these receptors in mouse La and BL cells with a distribution generally comparable with that found in rats. The notable concentration of strongly reactive 5-HT_{2C}-mRNA-labeled cells in the La of rats was not as obvious in mice. A combination of IHC and ISH in the rat confirmed dual ISH findings documenting coexpression of NPY- with 5-HT_{1A}- as well as 5-HT_{2C}-mRNA. As in the rat, dual ISH in mouse revealed a lack of 5-HT₃ mRNA in NPY-producing interneurons in La and BL; further analysis of coexpression of the other 5-HT receptors in NPY- and PV-producing interneurons in mice are ongoing.

IHC showed that while in rats the highest density of NPY-ir neurons was seen in the La, this was not obvious in mice. The distribution of PV-ir interneurons as well as the frequency of appositions of 5-Htt-ir serotonergic and tyrosine hydroxylase (TH)-ir, presumably dopaminergic, fibers on PV- and NPY-ir interneurons in the La and BL was comparable in both species. Comparative analyses of wildtype and 5-Htt deficient mice La and BL showed similar distribution of these interneuron subclasses and of dopaminergic afferent fibers, and similar frequency of dopaminergic appositions on interneuron somata. Interestingly, quantitative analysis indicated a reduced density of NPY-ir neurons in the La and BL in 5-

Htt deficient mice while no significant difference was found for the density of PV-ir neurons. The findings support a modulatory function of monoaminergic input on important inhibitory intrinsic networks in the La and BL in mice as in rats, and provide a basis for further studies into the function of monoaminergic transmission in the corticolimbic circuitry governing emotion processing.

Identification of donor and target cells of the NO/cGMP pathway in the brain of *Tribolium castaneum*

Björn Trebels, Carsten M. Heuer¹, Joachim Schachtner¹

¹Philipps-Universität Marburg, Dept. Biology, Animal Physiology, 35032 Marburg, Germany

The coleopteran model organism *Tribolium castaneum* takes a phylogenetically more basal place than the fruit fly *Drosophila melanogaster*. Similar to the fruit fly the genome of the beetle is fully sequenced and the beetle is amenable to advanced genetic manipulations.

As a pest of stored cereal products, *T. castaneum* mainly orientates through olfactory stimuli. The processing of olfactory but also of other sensory stimuli requires anterograde and also retrograde communication between different neurons. The gaseous molecule nitric oxide (NO) is considered to be an important anterograde but also retrograde signaling substance in the nervous system. NO-donor-cells (see figure) were localized using immunohistochemistry against L-citrulline and NADPH-diaphorase stainings. To detect putative target cells (see figure) of NO in *T. castaneum*, brains were stimulated using the NO-donor sodium nitroprusside and a variety of phosphodiesterase-inhibitors. Afterwards immunohistochemistry with an antibody against cGMP was performed.

Strong diaphorase signals could be detected within all subunits of the mushroom bodies. Furthermore distinct staining was observed in the central body and in the antennal lobe glomeruli. These results were confirmed by the L-citrulline immunohistochemistry which revealed staining of antennal lobe interneurons, the medial tritocerebrum, the optic lobes and the mushroom body neuroblasts.

Strong cGMP signals could be detected in subpopulations of local interneurons of the antennal lobes and the mushroom body calyces, especially in the neuroblasts and their immediate progeny. Various immunoreactive cell bodies and fibers could also be detected in the optic lobes. In addition, we located strong cGMP signals in the medial tritocerebrum.

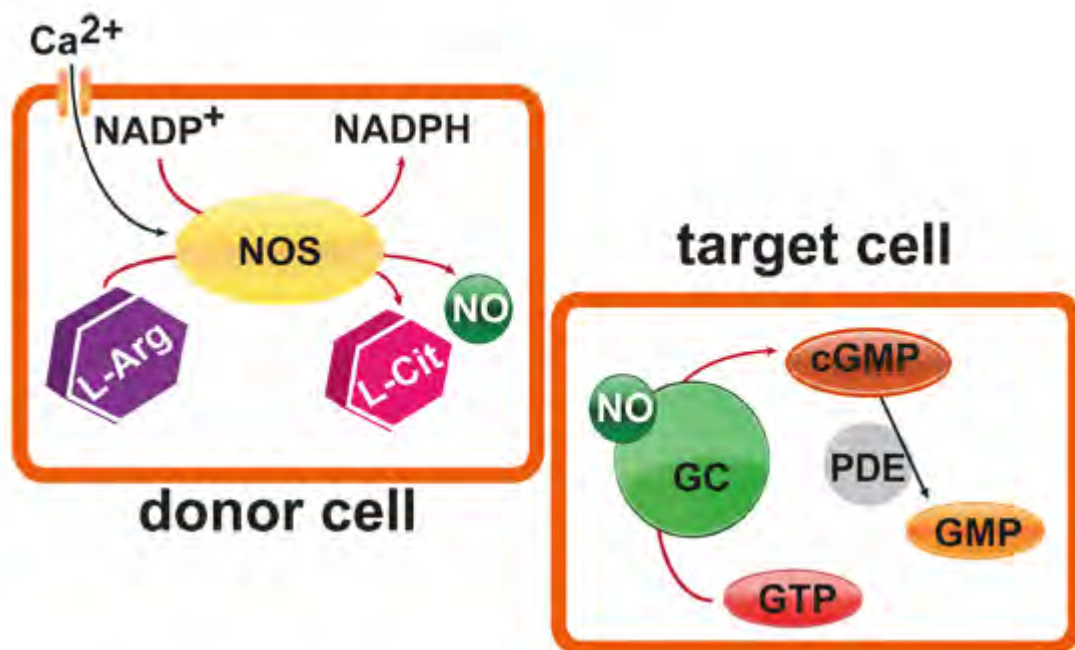

Nitric oxide/ cGMP-signaling regulates the excitatory/ inhibitory input onto hippocampal CA1 pyramidal cells

Angela Neitz, Thomas Mittmann¹

¹Johannes Gutenberg Universität, Inst. für Physiologie, Duesberweg 6, 55128 Mainz, Germany

An important feature of the brain is its potential to perform processes of learning and memory. In hippocampus synaptic plasticity has been shown to be the dominant cellular model for learning-associated changes in synaptic strength. This modulation comprises a variety of signaling molecules, in which nitric oxide (NO) has been proposed to act as a retrograde messenger during enhanced synaptic activity.

Most of its effects are mediated by two guanylyl cyclase NO-activated receptors (NO-GC1, NO-GC2), leading to a subsequent increase of intracellular cGMP levels. However, their physiological functions and their expression level in various cell types is still a matter of debate and rarely known.

The present work aimed to elucidate, how the NO-cGMP signaling pathway regulates the strength of excitatory and inhibitory inputs onto pyramidal cells in the hippocampal CA1 region. Knock-out (KO) mice, deficient in the NO- GC1 isoform were used to address this question. Analysis of the spatial expression of NO- GC1 defined a presynaptic localization in glutamatergic and GABAergic terminals in the stratum radiatum, the main input region of apical dendrites of CA1 pyramidal neurons.

Electrophysiological recordings revealed an increased inhibitory and a significantly reduced excitatory drive to pyramidal cells in NO- GC1 KO mice, as shown by alterations of spontaneous postsynaptic currents and stimulus evoked postsynaptic responses. This regulatory function of the NO- cGMP signaling pathway was verified in WT animals using the NO-GC inhibitor ODQ, resulting in KO-phenotyp. Vice versa the effects could be restored to WT-level in KO animals by cGMP application.

These results emphasize the important regulatory function of the NO-cGMP signaling pathway in the hippocampal network, resulting in an inhibition of the GABAergic input while strengthening the excitation. This regulatory mechanism is important for the initiation of long-term potentiation, an underlying mechanism of learning and memory consolidation. The present findings shed new light on the barely known physiological function of NO/cGMP signaling in regulation of neuronal network activity and synaptic plasticity.

Dissecting the role of serotonin in the feeding behavior of the adult *Drosophila melanogaster*.

Shreyas Venkataraman Jois, Henrike Scholz¹

¹Zoological institute, Animal physiology, Zülpicher straÙe 47b, 50674 Cologne, Germany

Extensive studies on the presynaptic serotonin transporter (5-HTT) strongly suggest that it is an important regulator of alcohol consumption in humans (Heinz et al., 2000). Also, studies show that the synaptic serotonin levels and alcohol consumption are inversely related; low brain serotonin levels correlate with high ethanol intake (Murphy et al., 1982; Higley et al., 1996), and drugs that increase synaptic serotonin levels either by preventing serotonin reuptake, such as selective serotonin reuptake inhibitors (SSRIs) (Borg et al., 1985, Naranjo et al., 1990, LeMarquand et al., 1994, Maurel et al., 1999), or by stimulating extracellular serotonin release, such as dexfenfluramine (Higgins et al., 1992) reduce ethanol intake in animal models of alcoholism. Knockout mice with targeted disruption of the 5-HTT gene adds to the information that long term inactivation of serotonin reuptake yields an obvious decrease in alcohol intake (Boyce-Rustay et al., 2006, Kelai et al., 2003). Later, in the larvae of *Drosophila melanogaster* it was also shown that increased 5-HT levels decreases feeding, while decreased 5-HT levels increases feeding (Neckameyer, 2010).

The aim of these studies is to investigate the function of 5HT on ethanol intake in *Drosophila*. Therefore we used *Drosophila* serotonin transporter (dSERT) mutants with varied levels of dSERT expression. These mutants were used to study the effect of altered serotonin levels in feeding. The capillary feeder assay (CAFE) was used to study the feeding behavior (Ja, et al., 2007; Devineni and Heberlein, 2009). Interestingly, our studies suggest that increased synaptic serotonin decreases feeding in adult flies. This is consistent with studies in mice. The data from dSERT mutants feeding behavior will be presented.

PKG and honey bee behavior

Markus Thamm, Ricarda Scheiner¹

¹Universität Potsdam, Zoophysiologie, Karl-Liebknecht-Straße 24-25, 14476 Potsdam, Germany

The honeybee foraging gene (*Amfor*) codes for a cGMP dependent protein kinase (PKG). An ortholog of this gene occurs in *Drosophila melanogaster* (*Dmfor*), where it is involved in regulating sucrose responsiveness, learning and food-searching behaviour. In honey bees, expression of *Amfor* was earlier shown to be involved in the transition from hive bee to forager, probably by mediating visual responsiveness through PKG. We suggest an additional role of this gene in regulating sucrose responsiveness, which reliably differs between nurse bees and foragers.

Here we show for the first time that *Amfor* occurs in two splice variants referred to as *Amfor a* and *Amfor β*. Expression analyses show differential expression of *Amfor a* but not of *Amfor β* in particular brain neuropiles of nurse bees and foragers. In addition, we have generated specific antibodies for each isoform. They work well in both Western blot analysis and immunohistochemistry. Both isoforms are differentially distributed throughout the honey bee: *Amfor_a*PKG is expressed in nearly all of the examined tissues, whereas *Amfor_β*PKG expression seems to be restricted to fat body and Malpighian tubules. These findings demonstrate a novel role for PKG in honey bee behaviour and help to elucidate the different functions of PKG genes in insects.

INFLUENCE OF THE EXTRACELLULAR MATRIX ON GLUTAMATE UPTAKE

Jose Francisco Alfaro Sanchis, Martin Heine¹, Artur Bikbaev¹, Renato Frischknecht²

¹RG Molecular Physiology, Leibniz Institute for Neurobiology; Brennekestr. 6, Magdeburg D-39118 Germany

²RG Brain Extracellular Matrix, Leibniz Institute for Neurobiology; Brennekestr. 6, Magdeburg D-39118 Germany

In the last years, it has been established that high concentrations of extracellular glutamate can contribute to the symptoms of several diseases such as Huntington or Alzheimer. Fast removal of glutamate from the synaptic cleft is therefore a crucial step in maintaining synapse function. Glutamate removal depends on the number and local density of the family members of the Excitatory aminoacid transporters (EAAT1, EAAT2...), the glutamate receptors and structural components as glia cell endfeet, size of synaptic cleft...The Extracellular Matrix (ECM), which embeds synaptic contacts, plays an important role in the regulation of synaptic functions and plasticity. Remarkable is also its ability to compartmentalize the neuronal surface and thereby acting as a passive diffusion barrier for cell surface molecules. Since the ECM is found at peri-synaptic sites where also glia endfeet are localized we wondered whether the ECM is involved in compartmentalization of the peri-synaptic volume and thus, diffusion and removal of glutamate. Here we are investigating specifically with EAAT2, who has been determined to play a major role in glutamate uptake at the synaptic cleft. In order to analyze the potential functional impact of the ECM on glutamate uptake we determined the changes in the network activity induced by modulation of the ECM density and EAAT2 function, using enzymatic digestion of ECM and pharmacology to antagonize transporter function. Network activity has been recorded from hippocampal cultures 21-28 days *in vitro* by the use of multielectrode arrays. Within these recordings we see strong correlation between neuronal activity and the ECM development. Further, in order to study in detail the spatial distribution of the EAAT2 in the synaptic and perisynaptic area of neuronal glia cells, we developed tools for single particle tracking of EAAT in neurons and glia cells.

Endocannabinoid Signalling in the Medial Superior Olive

Barbara Trattner, Sarah Berner^{1,2}, Benedikt Grothe^{1,3}, Lars Kunz¹

¹Division of Neurobiology, Department Biology II, Ludwig Maximilians University Munich, 82152 Planegg-Martinsried, Germany

²Graduate School of Systemic Neurosciences, 82152 Planegg-Martinsried, Germany

³Bernstein Center for Computational Neuroscience Munich, 82152 Planegg-Martinsried, Germany

For sound localisation animals exploit differences in arrival time of sound waves at both ears. These cues are computed in the medial superior olive (MSO), which is a nucleus located in the auditory brainstem. Despite the required temporal precision, dynamic changes induced by neuromodulators are of great importance in this system.

We studied the role of the endocannabinoid system in the MSO of the Mongolian gerbil using immunohistochemical stainings and patch-clamp recordings from neurones in acute brain slices.

Immunohistochemically, we found a predominantly presynaptic localisation of CB1 during the period of hearing onset, i.e. P10-P15. This distribution completely reverted during late postnatal development to almost exclusively postsynaptic localisation of CB1. In addition, a glial subpopulation expresses high amounts of CB1. The endocannabinoid-synthesising enzymes diacylglycerol lipase α/β ; were localised to the soma of postsynaptic cells at all developmental stages tested.

In accordance with immunohistochemical results, depolarisation-induced suppression of inhibition and excitation were successfully elicited between P10-P15. In animals older than P20 physiological evidence for presynaptically located CB1 receptors could not be found, however a CB1-dependent hyperpolarising effect on the resting membrane potential by endocannabinoids was found. This effect could be induced by high-activity action potential firing as well as by pharmacological activation of CB1 receptors. Voltage-clamp recordings suggest that an increased K^+ conductance underlies this hyperpolarisation. In addition, we could show that endocannabinoids modulate glycinergic currents by directly binding to postsynaptic glycine receptors.

Our results suggest that the endocannabinoid system plays an important role in the physiology of auditory neurones. In animals aged P10-P15 over-excitation of these neurones might suppress CB1 expressing inputs retrogradely. This mechanism could reduce the spontaneous activity occurring before hearing onset. In older animals, i.e. after the refinement of auditory connections by exposure to the acoustical environment, endocannabinoids seem to adjust the activity level of these neurones by postsynaptic mechanisms. This adjustment could represent a negative feedback regulation, dampening the neuronal activity upon increased excitement.

Descending OA3/TA interneurons of the locust brain

Sergej Hartfil, Dr. Natalia Kononenko², Julia Willer³, Prof. Dr. Hans-Joachim Pflüger⁴

¹Freie Universität Berlin, Institut für Biologie - Neurobiologie, Königin-Luise-Str. 28/30, 14195 Berlin, Germany

²Freie Universität Berlin, Institut für Chemie und Biochemie, Takustr. 6
14195 Berlin

³Freie Universität Berlin, Institut für Biologie - Neurobiologie, Königin-Luise-Str. 28/30, 14195 Berlin, Germany

⁴Freie Universität Berlin, Institut für Biologie - Neurobiologie, Königin-Luise-Str. 28/30, 14195 Berlin, Germany

In insects, octopamine and its precursor tyramine are both known to act as neurotransmitters and neuromodulators. Most cells are either purely tyraminergetic or tyraminergetic/octopaminergic. However, in locusts, Kononenko (Kononenko et al., 2009) identified descending interneurons of the brain, switching from tyramine to octopamine under stressful conditions, which we labelled as OA3/TA cluster. We currently aim to analyse cell properties, morphologies and sensory input of these cells by intracellular recordings, subsequent dye injection and immunocytochemistry. Preliminary data suggest, that neurons of the OA3/ TA cluster receive a wide range of mechanosensory input, especially from the abdominal and thoracic region, but also from legs. We suggest, that these cells may be interesting candidates for mediating modulating actions in the thoracic ganglia dependent on the specific behavioural conditions.

Poster Topic

T5: G Protein-linked and other Receptors

- T5-1A** Thrombin regulation of synaptic transmission: implications for seizures onset.
Nicola Maggio, Carlo Cavaliere, Michele Papa, Ilan Blatt, Joab Chapman, Menahem Segal
- T5-2A** Calcineurin – functional implications for a neuronal protein phosphatase in an insect model for fluid secretion
Kristoffer Heindorff, Bernd Walz, Otto Baumann
- T5-3A** Confocal Imaging of Receptor Mediated PI(4,5)P₂-Dynamics in CA1 Pyramidal Neurons
Sandra Hackelberg, Dominik Oliver
- T5-1B** GABA_B receptor-mediated inhibition of synaptic input onto somatostatin-immunoreactive interneurons in the hippocampus
Sam Anthony Booker, Annabelle L Gee, Jie Song, Akos Kulik, Imre Vida
- T5-2B** Cockroach GABA_B receptor subtypes
Stefanie Blankenburg, Wolfgang Blenau
- T5-1C** Differential sensitivity of two fluorescent biosensors to receptor-induced PIP₂ depletion.
Olga Nikolaevna Ivanova, Dominik Oliver
- T5-2C** The effects of stress on galanin peptide system in the rat pituitary: expression of mRNA and immunohistochemistry of galanin receptor subtypes
Vera Klenerova, Sixtus Hynie
- T5-1D** Biosensor Imaging shows that Inhibitors of Type 10 Phosphodiesterase Increase PKA activity Specifically in Striatal Neurons of the Indirect Pathway
Marina Polito, Liliana R.V. Castro, Danièle Paupardin-Tritsch, Pierre Vincent
- T5-2D** Alanine-87-Threonine polymorphism of the human P2Y₁₁ receptor impedes receptor internalization in HEK293 cells and impacts calcium signalling and ERK phosphorylation as well as receptor resensitization.
Georg Reiser, Michael Haas, Ahmed Shaaban

Thrombin regulation of synaptic transmission: implications for seizures onset.

Nicola Maggio, Carlo Cavaliere², Michele Papa², Ilan Blatt³, Joab Chapman³,
Menahem Segal⁴

¹The Chaim Sheba Medical Center, Neurology, Tel HaShomer, 52621 Ramat Gan, Israel

²Laboratory of Morphology of Neuronal Networks, Dipartimento di Medicina Pubblica, Clinica e Preventiva, The Second University of Naples, 80138 Naples, Italy.

³Department of Neurology and The Joseph Sagol Neuroscience Center, The Chaim Sheba Medical Center, 52621 Tel HaShomer, Israel; Department of Neurology, The Sackler Faculty of Medicine, Tel Aviv University, 69978 Tel Aviv, Israel.

⁴Department of Neurobiology, The Weizmann Institute of Science, 76100 Rehovot, Israel.

Seizures are a common outcome of cerebrovascular events as well as of traumatic brain injuries. Thrombin, a protease-activated receptor (PAR) agonist, has been implicated in the onset of seizures in these settings, yet its mode of action is not entirely clear. In this study, the effect of Thrombin and a PAR-1 agonist on neuronal excitability and synaptic currents was assessed by whole cell-patch recordings of pyramidal neurons in rat hippocampal slices. In addition, PAR-1 distribution in different hippocampal regions was assessed using immunohistochemistry. We found that thrombin caused an increase in spontaneous action potential discharges of CA3 but not of CA1 pyramidal neurons. When excitatory synaptic activity was blocked, thrombin caused a marked reduction in spontaneous IPSCs in CA3 neurons, and a marked increase in the frequency of IPSCs in CA1 neurons. These effects are likely to be local, as they were reproduced in TTX-treated slices. In parallel, thrombin increased both the frequency and the amplitude of mEPSCs only in CA3 neurons. These effects were blocked by a selective PAR-1 antagonist. The higher expression of PAR-1 in stratum lucidum of CA3 is correlated with the effects of thrombin in this region. These results suggest that thrombin triggers the generation of epileptic seizures by reducing the inhibitory and increasing the excitatory tone in CA3 neurons, providing a novel insight to the pathophysiology of seizures following cerebrovascular events and present new avenues for therapeutic intervention.

Calcineurin – functional implications for a neuronal protein phosphatase in an insect model for fluid secretion

Kristoffer Heindorff, Bernd Walz¹, Otto Baumann¹

¹University of Potsdam, Institute of Biochemistry & Biology, 14476 Golm, Germany

²current address: University of Saarland - School of Medicine, Department of Physiology, 66421 Homburg, Germany

Fluid secretion in salivary glands of the blowfly, *Calliphora vicina*, is induced by the neurohormone serotonin (5-HT). Binding of 5-HT to two distinct G-protein-coupled receptors leads to co-activation of the InsP₃/Ca²⁺ and the cAMP signalling pathways (Berridge and Heslop, 1981), thus promoting the secretion of a KCl-rich saliva.

Interestingly, there is evidence for extensive crosstalk between both pathways. Ca²⁺ positively affects cAMP signalling via a Ca²⁺/calmodulin-dependent adenylyl cyclase (Heindorff *et al.*, 2012). In turn, cAMP sensitizes 5-HT-induced Ca²⁺ release and signalling in a protein kinase A (PKA)-dependent manner (Schmidt *et al.*, 2008; Fechner *et al.*, 2012). In search for the protein phosphatase that antagonizes the effect of PKA on Ca²⁺ signalling, we found: (1) Inhibition of the Ca²⁺/calmodulin-dependent phosphatase 2B (calcineurin, PP2B) led to a sensitization of 5-HT-dependent Ca²⁺ signalling. (2) Inhibition of protein phosphatases 1 and 2A had no effect. These results imply an *in vivo* role of PP2B in desensitization of 5-HT-induced Ca²⁺ signalling. This mechanism might indeed antagonize the effect of PKA in our system. Further support for this hypothesis comes from ongoing pharmacological experiments, since the effect of an inhibition of PP2B on Ca²⁺ signalling seems to be dependent on the activity of PKA.

In summary, we propose a model, in which PP2B and PKA are functional antagonists that affect Ca²⁺ signalling in salivary glands of the blowfly and increase the regulatory complexity of this system.

Funded by Deutsche Forschungsgemeinschaft (Wa 463/9-6).

- Berridge and Heslop (1981) *Br J Pharmacol* 73: 729-738
- Fechner *et al.* (2012) *Cell Calcium* (in press)
- Heindorff *et al.* (2012) *Cell Calcium* 52: 103-112
- Schmidt *et al.* (2008) *BMC Physiol.* 8: 10

Confocal Imaging of Receptor Mediated PI(4,5)P₂-Dynamics in CA1 Pyramidal Neurons

Sandra Hackelberg, Dominik Oliver¹

¹Philipps Universität Marburg, Neurophysiologie, Deutschhausstraße 1-2, 35032 Marburg, Germany

Phosphoinositides (PI) contribute to the regulation of diverse cellular processes. Among these, the modulation of synaptic endocytosis and exocytosis and the activity of ion channels are of particular importance to neurons. Previous studies on the impact of phosphoinositides on ion channels indicated that various channel types can be modulated by phosphatidylinositol(4,5)biphosphate (PIP₂), including Kv, Cav, TRP, and HCN channels. Usually, PIP₂ dependence has been inferred from experiments involving application of exogenous phosphoinositides or from overexpression of PIP₂-metabolizing enzymes in heterologous expression systems or isolated neurons. Under physiological conditions, the activity of specific cellular lipid kinases, phosphatases and lipases may thus control neuronal excitability by dynamically altering PI levels. Yet, the extent to which changes in membrane PI concentrations actually occur during physiological neuronal activity has not been addressed in situ. However, knowledge of PI dynamics in neurons in their native environment is prerequisite for understanding the physiological importance of PIs. Thus, we aimed to analyze receptor-mediated phosphoinositide dynamics in acute brain slices, with the focus on PIP₂.

To approach this problem, we set out to visualize PIP₂ dynamics upon receptor activation in CA1 hippocampal pyramidal neurons. In these neurons, receptors employing Gαq proteins alter the activity of several ion channels and signaling is known to induce PIP₂ cleavage by activation of phospholipase C. Monitoring of PIP₂ levels was achieved by confocal imaging of GFP-coupled specific PI-binding domains (Tubby-C and PH domain).

These PI-probes were successfully expressed in vivo by stereotactic injection of lentiviral vectors into the hippocampal region of young rats. Observation of PI-probe localization allowed assessment of PIP₂ dynamics in acute hippocampal brain slices upon agonist application. Further refinement of the method may help to elucidate the physiological relevance of PI dynamics in neurons.

GABA_B receptor-mediated inhibition of synaptic input onto somatostatin-immunoreactive interneurons in the hippocampus

Sam Anthony Booker, Annabelle L Gee³, Jie Song¹, Akos Kulik², Imre Vida¹

¹Institute of Integrative Neuroanatomy, NeuroCure Cluster of Excellence, Berlin, Germany

²Institute of Anatomy, University of Freiburg, Freiburg, Germany

³School of Biology, University of Glasgow, Glasgow, UK

Somatostatin-immunoreactive (SSt-IR) interneurons in the neocortex play a pivotal role in feedback inhibition and the generation of theta-frequency oscillations. The somatodendritic domain of these interneurons are known to be strongly modulated by metabotropic glutamate receptors, however the role of GABA_B receptor (GABA_BR) mediated inhibition is not understood.

GABA_{B1} subunit immunofluorescent labelling in SSt-IR somata was higher than in CA1 pyramidal cells at the light microscopic level. Surprisingly, at the electron microscopic level, immunogold labeling against GABA_{B1}, in immunoperoxidase labeled SSt dendrites, was ~80% lower than on the dendrites of neighboring putative CA1 pyramidal cells. To confirm this finding we recorded GABA_BR-mediated IPSCs in identified SSt-IR interneurons. Extracellular stimulation to either str. oriens or str. radiatum, in the presence of blockers of fast ionotropic transmission revealed that GABA_BR-mediated slow IPSCs were small in SSt-IR interneurons, ~10% of the amplitude of slow IPSCs recorded in CA1 pyramidal cells. Consistently, bath application of the GABA_BR agonist baclofen induced only small changes in whole-cell currents of voltage-clamped interneurons. Both slow IPSCs and baclofen-induced whole-cell currents were blocked by the selective GABA_BR antagonist CGP-55,845. To assess whether GABA_BRs could modulate synaptic input onto SSt-IR interneurons, we evoked pharmacologically isolated fast monosynaptic EPSCs and IPSCs by extracellular stimulation to the alveus and str. oriens, respectively. Bath application of baclofen strongly inhibited both excitatory and inhibitory responses to approximately 20% of control amplitudes, both of which were fully recovered by application of CGP-55,845.

Our results suggests that while SSt-IR interneurons possess very low levels of functional post-synaptic GABA_BRs; GABAergic and glutamatergic synaptic input onto these cells are tightly modulated by the GABAergic system, via GABA_BRs.

Cockroach GABA_B receptor subtypes

Stefanie Blankenburg, Wolfgang Blenau²

¹University of Potsdam, Department of animal physiology, Karl-Liebknecht-Str. 24-25, Potsdam, Germany

²Goethe University Frankfurt, Institute for bee research (Polytechnische Gesellschaft), Karl-von-Frisch-Weg 2, Oberursel, Germany

The action of γ -aminobutyric acid (GABA), the predominant inhibitory neurotransmitter in the central nervous system, can be mediated via ionotropic GABA_A receptors and metabotropic GABA_B receptors. While much research has been done on characteristics and function of vertebrate GABA_B receptors, up to date little is known about insect GABA_B receptors.

In the American Cockroach *Periplaneta americana*, GABA has a modulatory effect onto saliva production. The innervation of the paired acinar -type salivary gland arises, among others, from the subesophageal ganglion (SEG). The SEG contains two paired salivary neurons (SNs) with thick axons and several thin neurons with thinner axons sending these axons through the salivary duct nerve. While SN1 is known to be dopaminergic, SN2 is GABAergic and the several thin fibers are serotonergic. The biogenic amines dopamine and serotonin elicit salivation, whereas GABA acts somehow presynaptic and enhances the fluid and protein secretion. The action of GABA can be mimicked or blocked by the application of GABA_B receptor agonists and antagonists, respectively.

Due to the evidence of the physiological relevance of this receptor, this project focuses on the characterization and precise localization of GABA_B receptors in *P. americana*. Due to the fact that the genome of *P. americana* is not sequenced yet, we used PCR with degenerate primers followed by RACE-PCR in order to isolate cDNA fragments encoding the full-length GABA_B receptor subtype 1 and the full-length GABA_B receptor subtype 2 (PeaGB1 and PeaGB2). The deduced amino acid sequences reveal characteristics common to all G protein-coupled receptors. Moreover they show a high degree of conservation to vertebrate and invertebrate GABA_B receptor subtypes. For a functional analysis the receptor subtypes will be heterologously expressed in HEK293 cells. In order to investigate the distribution of the GABA_B receptor subtypes we raised polyclonal antisera directed against selected regions of these receptor subtypes. This research gives new insights into GABA_B receptors in invertebrates.

This work was supported by the German Research Foundation (BL 469/4).

Differential sensitivity of two fluorescent biosensors to receptor-induced PIP₂ depletion.

Olga Nikolaevna Ivanova, Dominik Oliver¹

¹Institute of Physiology and Pathophysiology, AG Neurophysiology, Deutschhausstraße 2, 35032 Marburg, Germany

Depletion of membrane bound second messenger PIP₂ by PLC regulates many cellular processes such as activity of ion channels, cytoskeleton remodelling and vesicle trafficking.

Fluorescent biosensors based on PIP₂ binding domains are useful tools to address PIP₂ dynamics in living cells. Degree of membrane association of PH-domain or tubby-CT is a direct measure for the PIP₂ concentration within the membrane.

Fluorescently tagged PH-domain showed translocation from the membrane to the cytosol during PLC activation in CHO cells via the exogenous muscarinic M1 receptor indicating PIP₂ depletion. However, although tubby-CT showed translocation in some cells, responses were highly variable and loosely correlated to degree of PH-domain translocation. Moreover, EC₅₀ for Tubby-CT was about 5 fold higher than for PH-domain upon muscarinic stimulation and 3 fold higher upon purinergic stimulation of PLC.

These observations cannot be explained simply by differential affinity of the sensors. First, depletion of PIP₂ by a recruitable phosphatase or sequestering by neomycin shows no preferential unbinding of PH-domain. Second, in case of endogenous M1 receptor activation in CA1 pyramidal neurons both sensors translocate similarly.

Thus, a pool of PIP₂ inaccessible to exogenous M1 receptor-activated PLC in CHO cells exists. Tubby-CT is a promising tool to address the question which component of Gq-coupled signaling cascade in CHO cells is missing or misslocalized to mimic endogenous M1 receptor activation.

The effects of stress on galanin peptide system in the rat pituitary: expression of mRNA and immunohistochemistry of galanin receptor subtypes

Vera Klenerova, Sixtus Hynie¹

¹Charles University of Prague, 1st Faculty of Medicine, Neuropharmacology, Albertov 4, 128 00 Prague 2, Czech Republic

Galanin peptide system, mainly galanin-like peptide (GALP) and galanin (GAL), are widely distributed in the central nervous system and in the periphery. GALP and GAL have a wide spectrum of biological activities including the regulation/modulation neuroendocrine and behavior functions. Their dysfunctions are known to be involved in many pathologies, including regulation of feeding, gastrointestinal motility, learning and memory, pain perception, neuroendocrine control and also anxiety-like behaviors and stress responses. GALP is a 60-amino acid peptide and GAL is consisting of 29-30 amino acids and they exert its effects by activation of three receptor subtypes coupled to G regulatory proteins, GalR1, GalR2 and GalR3, using different messenger cascades.

Our previous results demonstrated that galanin increased locomotor behavior and this effect was antagonized by the drug called M40 (galanin fragment 1-13 Pro-Pro-Ala-Leu-Ala-Leu-Ala-amide). This finding indicates that both peptides, agonist as well as antagonist, penetrate the blood brain barrier. These results also suggest that galanin elicits the anxiolytic-related and anti-stress effects which are dependent on the activity of hypothalamic-pituitary-adrenal axis. Since the adenohypophysis (AH) is a crucial part of this axis and since there are many controversies about the involvement of GALP, GAL and individual galanin receptor subtypes in this tissue, we estimated presence of these proteins by expression of mRNA and immunohistochemically with specific antibodies under basal conditions and after stress. We used male Wistar rats (VELAZ, CR) and acute restraint stress lasted for 60 minutes. Expression of mRNA was estimated by real time qPCR with the use of specific primers for all three known galanin receptor subtypes, GALP and GAL, and as a house keeping gene we used beta actin. Relative expression ratios were calculated by using the method of Livak and Schmittgen 2001, and results were calculated by ANOVA. For immunohistochemical detection of galanin receptor subtypes we used primary polyclonal antibodies (Alomone Labs, Israel), GALP (Life Span, USA) and secondary antibodies Alexa Fluor 488 (Invitrogen, CA, USA). The images were analyzed by ImageJ software and specificity of antibodies was determined by the Western Blot procedure. By using qPCR we have demonstrated the presence of all three GAL receptor subtypes and the highest expression had GalR2. This might be due to the messenger cascade that is utilized by GalR2. The dynamics of acute restraint stress effects seems to be similar as the expression of all galanin receptor subtypes under basal condition. In our study with the immunohistochemistry procedure, we clearly demonstrated that AH expresses all galanin receptor subtypes. The specificity of the reaction was confirmed by the Western Blot. The effect of restraint stress revealed statistical increase of GalR2 receptor subtype with the increase of the number of positive cells as well as the specific signal density.

Acknowledgements: Supported by grants PRVOUK-P25/LF1/2, GAUK 85210 and SVV 264514.

Biosensor Imaging shows that Inhibitors of Type 10 Phosphodiesterase Increase PKA activity Specifically in Striatal Neurons of the Indirect Pathway

Marina Polito, Liliana R.V. Castro², Danièle Paupardin-Tritsch³, Pierre Vincent⁴

¹²³⁴CNRS UPMC, UMR7102 "Neurobiology of Adaptive Processes", 9 quai St Bernard, F-75005 Paris, France

The cyclic AMP (cAMP) / protein kinase A (PKA) signaling cascade modulates various aspects of neuronal functions. Phosphodiesterases degrade cAMP and thus play an important role in the negative regulation of the cAMP/PKA signaling pathway. Recent data have shown that inhibitors of type 10 phosphodiesterase (PDE10) have antipsychotic effects improving the animal correlates of both the positive and negative symptoms of schizophrenia, raising considerable hopes in finding a better treatment for schizophrenia. Surprisingly, while schizophrenia was generally considered a dysfunction in the prefrontal cortex, PDE10 is highly and exclusively expressed in striatal neurons. The cellular mechanism of action of PDE10 blockers remains however poorly understood.

The recent development of genetically-encoded sensors allows time-lapse imaging at the cellular level in live brain slice preparations, providing real-time access to the spatial and temporal characteristics of cAMP/PKA signaling. We expressed the AKAR3 and novel cAMP biosensors in neurons in striatal brain slices, and monitored with wide-field or two-photon ratiometric imaging the effects of PDE10 blockers on the cAMP/PKA cascade. In basal condition, inhibition of PDE10 (PQ10 or MP10) increased PKA activity reversibly, specifically in neurons of the indirect pathway which express the A2A adenosine and D2 dopamine receptors. This effect remains in the presence of blockers of all electrical activity and synaptic transmission, showing that it does not result from local network activity. However, PQ10 increased cAMP concentration equally in both types of medium spiny neurons, showing that tonic cAMP production and PDE10-mediated degradation is similar in both cell types. Using pharmacological blockade of phosphatases, we showed that protein phosphatase 1 is more active in spiny neurons of the direct pathway than in neurons of the indirect pathway.

In conclusion, the inhibition of PDE10 increases PKA-dependent phosphorylation level only in neurons of the indirect pathway, precisely where the inhibition of D2 receptors by antipsychotics would also lead to increased PKA activity. At the cellular level, our data provide the first functional link between the antipsychotics which target the D2 receptor and PDE10. These data will hopefully help understand the molecular underpinnings of antipsychotic drug action.

Alanine-87-Threonine polymorphism of the human P2Y₁₁ receptor impedes receptor internalization in HEK293 cells and impacts calcium signalling and ERK phosphorylation as well as receptor resensitization.

Georg Reiser, Michael Haas¹, Ahmed Shaaban¹

¹Otto-von-Guericke Universität, Institut für Neurobiochemie, Leipziger Str. 44, 39120 Magdeburg, Germany

A statistical link between the Alanine-87-Threonine (A87T) polymorphism of the human P2Y₁₁ nucleotide receptor and risk for acute myocardial infarction as well as elevated levels of C-reactive protein has been proposed (Amisten et. al 2007), as based on the Malmö diet and cancer study. In this study, the pharmacological and functional characteristics of the P2Y₁₁(A87T) receptor have been investigated in 1321N1 astrocytoma cells and HEK293 cells. For HEK293 cells, stably expressing the P2Y₁₁A87T receptor, we show a reduced potency of ATP, BzATP, and 2-MeS-ADP as well as a complete loss of nucleotide-induced receptor internalization. Furthermore, we found an increased ability for receptor resensitization in HEK293 cells expressing the P2Y₁₁A87T receptor after prolonged receptor desensitization. In 1321N1 and HEK293 cells, the increase of nucleotide-induced cAMP production was comparable for the P2Y₁₁ receptor and the A87T variant. However, the ATP-induced elevation of phospho-ERK concentration was significantly lower in HEK293 cells expressing the P2Y₁₁A87T receptor than in cells expressing the wildtype P2Y₁₁ receptor. In this study, we included the additional, engineered by us, variants of the P2Y₁₁ receptor, the Alanine-87-Serine (A87S) and Alanine-87-Tyrosine (A87Y) receptor, in order to elucidate whether a shift in amino acid polarity alone can account for the characteristics of the P2Y₁₁A87T receptor. We found that both variants can partly or completely rescue the calcium responses to BzATP and 2-MeS-ADP in HEK293 cells. The P2Y₁₁A87Y receptor, furthermore, is unable to undergo nucleotide-induced internalization in HEK293 cells, while the P2Y₁₁A87S receptor shows slight internalization. In summary, our data support the hypothesis of a possible physiological impact of this A87T receptor polymorphism and therefore on the development of acute myocardial infarction. We present a model for the involvement of this A87T receptor mutant in inflammatory reactions.

Poster Topic

T6: Ligand-gated, Voltage-dependent Ion Channels, and Transporters

- T6-1A** The extracellular matrix affects surface expression of GluN2B containing NMDA receptors
Barbara C. Schweitzer, Laurant Groc, Martin Heine, Renato Frischknecht
- T6-2A** Multiple binding sites enable a dynamic interaction of glycine receptors and gephyrin
Nora Grünewald, Vanessa Kress, Tobias Lamkemeyer, Günter Schwarz
- T6-3A** Aversion to nicotine is regulated by the balanced activity of $\beta 4$ and $\alpha 5$ nicotinic receptor subunits in the medial habenula
Silke Frahm, Marta Anna Slimak, Leiron Ferrarese, Julio Santos-Torres, Beatriz Antolin-Fontes, Sebastian Auer, Sergey Filkin, Stephanie Pons, Jean-Fred Fontaine, Victor Tsetlin, Uwe Maskos, Ines Ibanez-Tallon
- T6-4A** Acid-sensing Ion Channels and Hepatic Encephalopathy
Pia Bresenitz, Stefan Gruender
- T6-5A** Prevention of behavioral and cortical excitability in an M-channel dependent epilepsy phenotype
Stephan Marguet, Quyen Le, Andrea Merseburg, Axel Neu, Fabio Morellini, Dirk Isbrandt
- T6-6A** Trafficking analyses of the cation chloride cotransporter KCC2
Timo Beyer, Anna-Maria Hartmann, Hans Gerd Nothwang
- T6-7A** Developmental differences in pH regulation and influence of pH on neuronal excitability
Benedikt Salmen, Joerg Roesner, Dietmar Schmitz
- T6-8A** Which GABA_A Receptor Subunits Are Necessary for Tonic Inhibition in Central Amygdala?
Hector Romo-Parra, Tatyana Kanishkova, Pape Hans-Christian
- T6-1B** New aspects of Ca_v1.4 L-type calcium channel mutants linked to Congenital Stationary Night Blindness Type 2
Verena Burtscher, Klaus Schicker, Sakine Korkmaz, Christof Kugler, Anamika Singh, Thomas Stockner, Alexandra Koschak
- T6-2B** Modeling the Relations between Neuronal Membrane Potentials, Ion Currents and Ion Channel States
Aubin Tchaptchet, Hans Albert Braun
- T6-3B** Distribution and Functional Implication of Voltage-Gated Ca²⁺ Channels in the Septohippocampal System

Christina Henseler, Magdalena Elisabeth Siwek, Anna Papazoglou, Marco Weiergräber, Karl Broich

- T6-4B** Loop D of the human Glycine receptor $\alpha 1$ subunit – a susceptible site for mutations associated with Hyperekplexia
Natascha Schaefer, Christoph Kluck, Solveig Schulz, Carmen Villmann
- T6-5B** Reduced hippocampal GABAergic activity in a low birth weight rat model of depression
Zita Dosa, Jose Luis Nieto-Gonzalez, Betina Elfving, Karin S. Hougaard, Mai M. Holm, Gregers Wegener, Kimmo Jensen
- T6-6B** N- and C-termini of ASIC4 direct the channel into early endosomes
Katharina Friedrich, Georg Polleichtner, Stefan Gründer
- T6-7B** Inter-subunit disulfide bond formation indicates P2X3 receptor ectodomain movement
Maria Kowalski, Peter Illies, Thomas Riedel
- T6-8B** Differential expression of hyperpolarization-activated cyclic nucleotide gated channel isoforms (HCN1–4) in neocortical tissues from patients with temporal lobe epilepsy
Stephan Wierschke, Peter Horn, Christoph Dehnicke, Anja U Bräuer, Rudolf A Deisz
- T6-1C** Ca^{2+} channel promiscuity of small conductance Ca^{2+} -activated K^{+} channels (SK) in hippocampal pyramidal neurons
Felix Benninger, Shmuel Chen, Yoel Yaari
- T6-2C** Differential regulation of chloride transporter expression by bioelectric activity in chicken auditory brainstem *in vitro*
Marcus Joseph Wirth, Desirée Kupsch, Julia Krebbers, Hermann Wagner
- T6-3C** Modulatory effect of histamine on ligand-gated ion channels
Ulrike Thiel, Philipp Lorenz, Olaf Kletke, Hanns Hatt, Günter Gisselmann
- T6-4C** Alterations in input resistance, spike threshold and firing properties of layers 2/3 pyramidal neurons following focal laser lesions in the rat visual cortex
Barbara Imbrosci, Thomas Mittmann
- T6-5C** Hippocampal vesicular GABA transporters as targets for *in vivo* labelling of inhibitory synapses and immunolesioning of GABAergic neurons
Wolfgang Härtig, Alán Alpár, Flavia Antonucci, Johannes Kacza, Claudia Verderio, Henrik Martens, Jens Grosche, Dominik Michalski, Michela Matteoli, Tibor Harkany
- T6-6C** Immunocytochemical and electrophysiological characterization of GFP-expressing GABAergic interneurons of the adult mouse cingulate cortex
Maria-Therese Riedemann, Bernd Sutor
- T6-7C** Activation of glycine receptors modulates spontaneous epileptiform activity in the immature rat hippocampus
Rongqing Chen, Akihito Okabe, Haiyan Sun, Salim Sharopov, Sergei N. Kolbaev, Ileana L. Hanganu-Opatz, Atsuo Fukuda, Heiko J. Luhmann, Werner Kilb

- T6-1D** Optochemical control of genetically engineered glutamate and acetylcholine receptors in *C. elegans*
Jatin Nagpal, Jana Liewald, Tatsuya Urushima, Dirk Trauner, Alexander Gottschalk
- T6-2D** Suppression of HCN channel-mediated current (I_h) in forebrain neurons impairs early postnatal sensorimotor development and alters neonatal cortical network activity
Andrea Merseburg, Anna Katharina Schlusche, Stephan Marguet, Jasper Grendel, Zhuo Huang, Mala Shah, Fabio Morellini, Dirk Isbrandt
- T6-3D** Dual function of TRPM8 as an ion channel and G protein-activating receptor
Christian Wetzel
- T6-4D** Novel splice variant of calmodulin inhibits human $Ca_v2.3$ E-/R-type voltage-gated Ca^{2+} channels in HEK-293 cells
Toni Schneider, Marcel A. Kamp, Behzad Shakeri, Juergen Hescheler, Lucie Parent
- T6-5D** DISSECTING THE ACTIVATION OF AMPA RECEPTORS
Andrew John Plested, Miriam Chebli, Hector Salazar, Valentina Ghisi, Jelena Baranovic, Kajta Faelber, Oliver Daumke
- T6-6D** Rab8a mediates acidosis-induced trafficking of NBCe1-A in hippocampal neurons
Eleni Roussa, Jan Manuel Speer, Oliver Oehlke
- T6-7D** Regulation of acid-base transporters in epilepsy
Magdalena Schroedl, Oliver Oehlke, Jan Manuel Speer, Eleni Roussa
- T6-8D** Lysophosphatidic acid activates spinal nerv TRESK background potassium channels
Sina Kollert, Frank Döring, Erhard Wischmeyer

The extracellular matrix affects surface expression of GluN2B containing NMDA receptors

Barbara C. Schweitzer, Laurant Groc², Martin Heine³, Renato Frischknecht¹

¹Neurochem., LIN Magdeburg, Magdeburg, Germany

²Cell. Physiol., CNRS, Bordeaux, France

³Mol. Physiol., LIN Magdeburg, Magdeburg, Germany

In late postsynaptic development when neuronal networks are established, a drop in structural plasticity can be observed. On the molecular level, neurotransmitter receptors are recruited and stabilized at synaptic contacts, which determine the mature properties of synaptic transmission. Key events are changes in the subunit composition of glutamate receptors of the NMDA subtype from heterodimers containing mainly GluN1/GluN2B subunits to heterodimers containing predominantly GluN1/GluN2A subunits. It has been shown that during this period the mobility of GluN2B containing NMDA receptors change.

At the same time the brain-specific form of the extracellular matrix (ECM), the so-called perineuronal net (PNN) is formed, which marks the end of the so-called juvenile plasticity. The PNN has been shown to stabilize synaptic contacts and alter receptor mobility on the neuronal surface. With regard to these results and the overlap in timing of these two developmental changes, we hypothesize an influence of the ECM on the characteristics of the GluN2B containing NMDARs.

To investigate this, we first tested whether enzymatic digestion of the ECM by hyaluronidase changes the surface expression of GluN2B containing NMDAR. First experiments have shown that there is an up regulation of the GluN2B subunits on the surface of cultured hippocampal neurons after removal of the ECM. This increase in surface expression rise from a change in the balance of endo- and exocytosis and not from an increase in gene expression. In further experiments we will analyze the possible signaling mechanism behind. Taken together, these results will shed new light into the mechanisms leading to synapse and neuronal network maturation and the impact of the ECM in this process.

Multiple binding sites enable a dynamic interaction of glycine receptors and gephyrin

Nora Grünewald, Vanessa Kress¹, Tobias Lamkemeyer², Günter Schwarz^{1,2,3}

¹University of Cologne, Institute of Biochemistry ²CECAD Cologne Excellence in Aging Research ³Center for Molecular Medicine Cologne, University of Cologne, Germany

Synaptic strength depends on the amount of functional neurotransmitter receptors at the postsynaptic membrane. Their continuous diffusion into and out of synaptic sites allows a rapid regulation of receptor numbers at synapses (Lévi *et al.*, 2008). Within the central nervous system, synaptic localization of inhibitory neurotransmitter receptors is mediated by the scaffolding protein gephyrin, which provides binding sites for the immobilization of GABAA receptors and glycine receptors (GlyRs). Due to its oligomerization properties, which include trimerization of the G-domain and dimerization of the E-domain, it is assumed that gephyrin forms complex clusters underneath the postsynaptic membrane that provide binding sites for the β -subunit of GlyRs (reviewed in Fritschy *et al.*, 2008). Consequently, GlyR stability at synapses depends on two types of interactions that need to be taken into account to explain the dynamic equilibrium at glycinergic synapses: gephyrin-gephyrin and gephyrin-GlyR interactions. Recent studies on gephyrin-GlyR interactions identified two different binding sites (Sola *et al.*, 2004, Schrader *et al.*, 2004). According to this a gephyrin trimer can bind to one high (0.022 μ M) and two low affinity (2.94 μ M) sites (Specht *et al.*, 2011). We identified the N-terminal part of the GlyR β -loop as the low affinity binding site and additionally show that the C-terminal part is responsible for the high affinity binding. ITC measurements with a short peptide of the GlyR β -loop C-terminus did not offer comparable affinities like the high affinity site of the full-length receptor loop, indicating that conformation might have a distinct impact on the strength of binding. Moreover a recently identified interaction of the GlyR β -loop with the gephyrin C-domain might provide an additional explanation for the different binding sites between the receptor and the scaffolding protein. Using mass spectrometry, multiple peptides of the C-domain provided evidence that the interaction seems not to be constrained to the E-domain, as assumed so far. Since gephyrin is highly phosphorylated within the C-domain, we hypothesize that this region represents an additional site to dynamically regulate the interaction between gephyrin and GlyR β -loop.

Aversion to nicotine is regulated by the balanced activity of $\beta 4$ and $\alpha 5$ nicotinic receptor subunits in the medial habenula

Silke Frahm, Marta Anna Slimak¹, Leiron Ferrarese¹, Julio Santos-Torres¹, Beatriz Antolin-Fontes¹, Sebastian Auer¹, Sergey Filkin², Stephanie Pons³, Jean-Fred Fontaine⁴, Victor Tsetlin², Uwe Maskos³, Ines Ibanez-Tallon¹

¹Max-Delbrueck-Centrum, Molecular Neurobiology, Robert-Roessle-Str. 10, 13125 Berlin, Germany

²Shemyakin-Ovchinnikov Institute of Bioorganic Chemistry, Russian Academy of Sciences, Moscow, Russia.

³CNRS URA 2182, Département de Neurosciences, Institut Pasteur, 25 rue du Dr Roux, 75724 Paris Cédex 15, France.

⁴Computational Biology and Data Mining Group, Max-Delbrück-Centrum, Robert-Rössle-Str. 10, 13125 Berlin, Germany.

Nicotine dependence is linked to single nucleotide polymorphisms in the CHRNA3-CHRNA5 gene cluster encoding the $\alpha 3\beta 4\alpha 5$ nicotinic acetylcholine receptor (nAChR). Here we show that the $\beta 4$ subunit is rate-limiting for receptor activity, and that current increase by $\beta 4$ is maximally competed by one of the most frequent variants associated with tobacco usage (D398N in $\alpha 5$). We identify a $\beta 4$ specific residue (S435), mapping to the intracellular vestibule of the $\alpha 3\beta 4\alpha 5$ receptor in close proximity to $\alpha 5$ D398N, that is essential for its ability to increase currents. Transgenic mice with targeted overexpression of *Chrn4* to endogenous sites display a strong aversion to nicotine that can be reversed by viral-mediated expression of the $\alpha 5$ D398N variant in the medial habenula (MHb). Thus, this study both provides novel insights into $\alpha 3\beta 4\alpha 5$ receptor mediated mechanisms contributing to nicotine consumption, and identifies the MHb as a critical element in the circuitry controlling nicotine dependent phenotypes.

Acid-sensing Ion Channels and Hepatic Encephalopathy

Pia Bresenitz, Stefan Gruender¹

¹RWTH Aachen University, Institute of Physiology, Pauwelsstraße 30, 52074 Aachen, Germany

Acid-Sensing Ion Channels (ASICs) are activated by extracellular protons and abundantly expressed in the CNS. They play a critical role in synaptic signalling, learning and memory as well as in several neural disorders, e.g. ischemic brain injury.

Hepatic Encephalopathy (HE) is a neural disorder caused by acute or chronic liver failure and results in cognitive and motor impairments. While the physiological level of ammonium in the brain is low, in HE it reaches toxic concentrations and affects glial cells and neurons as well. It was shown that very high concentrations of extracellular ammonium induce ASIC currents in dopaminergic neurons.

Here, we investigated acute and chronic effects of pathophysiological ammonium concentrations on ASICs. Using the patch-clamp technique, we revealed an acute modulatory effect of ammonium on acid-induced ASIC current in cortical neurons. Heterologous expression of different ASIC subunits in CHO cells showed that this effect is specific for ASIC 1a. To elucidate chronic effects, we performed quantitative real-time PCR and found a down-regulation of all ASIC subunits present in cortical neurons after 10 days incubation with ammonium. Both effects, acute and chronic, were dose-dependent. Our results suggest an involvement of ASICs in the pathophysiology of hepatic encephalopathy.

Prevention of behavioral and cortical excitability in an M-channel dependent epilepsy phenotype

Stephan Marguet, Quyen Le¹, Andrea Merseburg¹, Axel Neu¹, Fabio Morellini¹, Dirk Isbrandt¹

¹Zentrum für Molekulare Neurobiologie, Experimental Neuropediatrics, Falkenried 94, 20251 Hamburg, Germany

The nervous system is vulnerable to perturbations during specific developmental periods. Insults during such critical time windows can have long-term consequences including neurological diseases, such as epilepsy. We report a pharmacological intervention timed during a critical neonatal period of cortex development which prevents pathology in a genetic epilepsy model.

We used mice with dominant-negative Kv7.2 subunits and suppressed Kv7/M currents, and by restricting Tet-off mediated transgene suppression to select time windows, we identified a critical period for M-currents. Mice with normal Kv7 expression during the first two postnatal weeks showed no phenotype, even if M-currents were suppressed during other periods. However, animals with dominant-negative Kv7.2 subunits expressed in early development were hyperactive and prone to seizures. Loss of M-currents in early development also disturbed hippocampal morphology, seen in the displacement and dispersion of CA1 pyramidal cells as well as the strong activation of microglia and astrogliosis.

To assess the effect of M-current suppression on network activity patterns we performed in-vivo silicon probe recordings in awake neonatal (P5-7) control and mutant mice. Visual cortical activity included spontaneous ~2-10s long oscillatory events in the beta frequency (12-28Hz) range, appearing predominantly in upper cortical layers. Such “spindle burst” events were significantly more frequent in mutants. In neonatal hippocampus, prominent activity patterns included sharp waves and “stratum radiatum oscillations” (SROs) of 2-5s in the 15-30Hz range, both of which had a tendency to follow movement twitches.

We tested whether we could prevent expression of the epilepsy phenotype by targeting treatment to the critical period of Kv7/M expression. Barbiturates and other GABA mimetics are typically used to treat seizures following neonatal insults, but control seizures in under fifty percent of infants and their prophylactic safety is questionable. Instead, we used the loop diuretic and sodium-potassium-chloride cotransporter (NKCC1) antagonist bumetanide, which has been proposed as a therapeutic option in neonatal epilepsy. Bumetanide reduces the intracellular chloride concentration of immature cortical neurons in vitro, attenuating GABA-mediated depolarization. We first checked bumetanide treatment was safe. Administration during the first two postnatal weeks revealed that except for a transient weight decrease in the 2nd to 4th weeks, which was fully recovered by the 8th week, bumetanide exhibited no deleterious effects in controls.

In Kv7/M-current-deficient mice, bumetanide treatment from P0 to P14 normalized neonatal in vivo cortical spindle burst rates, prevented structural damage in the hippocampus, and restored a wild-type behavioral phenotype. Our study shows that neonatal NKCC1 antagonism can effectively prevent the development of an M-current mediated chronic epilepsy phenotype. These results suggest that

prophylactically-safe interventions targeted to key developmental windows may be an effective strategy for protecting at-risk patients against disease pathology.

Trafficking analyses of the cation chloride cotransporter KCC2

Timo Beyer, Anna-Maria Hartmann¹, Hans Gerd Nothwang^{1,2}

¹Carl-von-Ossietzky-University Oldenburg, Department of Neurogenetics, Carl-von-Ossietzky-Strasse 9-11, 26111 Oldenburg, Germany

²Center for Neurosensory Research, Carl von Ossietzky University Oldenburg, Carl von Ossietzky Straße 9-11, D-26111 Oldenburg

The neuronal cation chloride cotransporter KCC2 is an integral plasma membrane protein, which transports chloride out of the cell. This activity causes an inwardly directed chloride gradient, thereby resulting in hyperpolarizing action of GABA and glycine. Transport by KCC2 is regulated on the transcriptional and the posttranscriptional level (Blaesse et al., 2009 Neuron review). On the protein level, phosphorylation and cell surface expression were shown to be intimately interweaved (Lee et al., 2007, Lee et al., 2010, Wake et al., 2007), and several regulatory phosphorylation sites have been identified. In contrast, not much is known about the internalization, recycling and degradation pathway of KCC2. Only recently, constitutive internalization via a dynamin - and clathrin -dependent pathway was reported in HEK-293 cells (Zhao B. et al., 2008). This process required a novel di-leucine motif at the C-terminus of KCC2 (Zhao B. et al., 2008). However, this study did not address the precise fate of internalized KCC2. To address this issue, we performed colocalization studies of KCC2 and different Rab-GTPases and Arfs in COS-7 and HEK293 cell lines. Both protein classes label specific subcellular compartments. In parallel, thallium-flux measurements were performed to indirectly measure cell surface expression of KCC2 via its transport activity.

Using confocal microscopy, we observed strong colocalization of KCC2 and Arf6 (clathrin independent endocytosis and recycling), Rab5A (early endosome marker), Rab4A/B (fast recycling pathway), and EHD-1 (slow recycling pathway) in COS-7 cells. Only weak colocalization was observed with Rab7A (lysosomal marker), as well as with Rab11A/B and Rab8A/B (slow recycling pathway). Finally, no changes in KCC2 distribution were observed after cotransfection with different dynamin1/2 (endocytosis marker, including clathrin dependent endocytosis) and EPS15 (clathrin dependent endocytosis marker) constructs.

These results were corroborated by thallium -flux measurements. Cotransfection of functional Rab4B, EHD-1 or Arf6 mutants in a HEK293 cell line, expressing stably KCC2, led to decreased KCC2 transport activity. In contrast, Rab11A/B functional mutant constructs had no effect on transport activity.

Our data are consistent with a model, in which Arf6 participates in a clathrin-independent internalization of KCC2. After internalization, most KCC2 is recycled via both the fast (Rab4) as well as slow recycling pathway (EHD1, Arf6) back to the cell surface, whereas only a small amount of KCC2 is degraded in lysosomes (Rab7). To further corroborate these data, we currently investigate the effect of several functional Rab and Arf6 mutants on KCC2 subcellular localization and transport activity.

Developmental differences in pH regulation and influence of pH on neuronal excitability

Benedikt Salmen, Joerg Roesner¹, Dietmar Schmitz¹

1

Neuroscience Research Center
Charité Campus Mitte
Charitéplatz 1
10117 Berlin
Germany

Changes in brain pH influence the neurons excitability, therefore regulation and tight control of the interstitial and intracellular pH in the brain is therefore of pivotal importance. Using the pH sensitive fluorophore BCECF-AM ester we compared immature and mature tissue of acute hippocampal slices. This revealed a shift to more alkalotic intracellular pH values in the immature slices at an ACSF pH of ~7.3 as compared to the mature ones. Changing the ACSF pH to ~8.0 resulted in a larger intracellular effect in immature neurons, suggesting thus a reduced buffering capacity. These changes only occurred in bicarbonate buffered ACSF, but not in a HEPES buffered extracellular solution, pointing to a carbonate-ion mediated mechanism. Using electrophysiological standard techniques such as patch-clamp recordings and extracellular field potential measurements we tested the influence of extracellular pH changes on neuronal excitability. Increasing the extracellular pH resulted in a selective increase in the neuronal excitability in the immature tissue, accompanied also by an increase in GABAergic inhibitory transmission. The first did occur only in bicarbonate based ACSF, but not when pH changes were induced by HEPES buffered solutions. This suggests an intracellular mode of action being responsible for the observed increase in excitability. The subcellular localization of this effect seems to be neither axonal or synaptic, but dendritic. Further investigations excluded NMDA-receptors, GABAergic transmission, H-currents and several K⁺ conductivities as the potential molecular target.

Taken together, we show developmental difference in resting pH as well as in pH dynamics with respect to enforced changes. In addition, alkalotic changes also have different consequences for mature and immature hippocampal tissue.

Which GABA_A Receptor Subunits Are Necessary for Tonic Inhibition in Central Amygdala?

Hector Romo-Parra, Tatyana Kanishkova¹, Pape Hans-Christian¹

¹Universitätsklinikum Münster, Institut für Physiologie I, Robert Kochstr. 27a, 48149 Münster, Germany

Aim: GABA_A receptors can mediate both phasic (synaptic) and tonic (extrasynaptic) forms of inhibition. It has been proposed that tonic inhibition plays a critical role in controlling neuronal and network excitability. Modulation of tonic receptors represents a promising strategy for the development of new anticonvulsant, anxiolytic, and anaesthetic drugs. Despite extensive research on the role of GABA_A extrasynaptic receptors (GABA-ER), no evidence of a functional expression in the Central Amygdala (CeA) was reported so far. Here we investigate i) the expression of GABA-ER in situ and ii) the functionality of GABA-ER in the CeA by the application of GABA_A agonists and antagonists in vitro.

Methods: PCR and immunostaining against GABA-ER alpha5 and delta subunits were developed. Current- and voltage-clamp (whole-cell) recordings in CeA neurons from adult BL6 mice were carried out. Gabazine (GBZ), Picrotoxin (PTX), GABA-ER alpha5 subunit antagonist (L-655-708), delta agonist (THIP) and GABA transporter 1 (GAT-1) antagonist (NCC-711) effects on firing frequency and on holding voltage and current shift were studied.

Results: i) In situ, the presence of both GABA-ER subunits alpha5 and delta was confirmed in CeA by PCR and immunoassays. ii) In vitro, PTX abolished the mIPSCs and evoked a large outward shift in the holding current. In contrast, the high-affinity antagonist GBZ (10 and 50 μM) produced no significant or small positive shift in the holding current, respectively. Nonetheless, GBZ (at both concentrations) completely abolished the mIPSCs. In current clamp mode it produced a depolarization with an increase in excitability, seen by the increase in firing frequency. GBZ at low dose (0.5 μM) produced small negative shift that was reversed by the further application of PTX. The GABA-ER alpha5 subunit antagonist (L-655-708 5-10 μM) prevented the outward shift produced by PTX. The delta agonist (THIP, 1-10 μM) induced a large inward shift on the holding current that was blocked by the posterior application of PTX (100 μM). Finally, the GAT-1 transporter blocker (NCC-711; 5 μM) induced a negative shift in holding current and it did not prevent PTX effect.

Conclusion: The present data demonstrate that GABA_A receptors subunits alpha5 and delta mediate tonic inhibitory currents in mice central amygdala neurons and they might represent a key role in the regulation of fear expression.

New aspects of Ca_v1.4 L-type calcium channel mutants linked to Congenital Stationary Night Blindness Type 2

Verena Burtscher, Klaus Schicker¹, Sakine Korkmaz¹, Christof Kugler¹, Anamika Singh², Thomas Stockner¹, Alexandra Koschak¹

¹Medical University of Vienna, Center for Physiology and Pharmacology, Department of Neurophysiology and Neuropharmacology, 1090 Vienna, Austria

²University of Innsbruck, Institute of Pharmacy, Department of Pharmacology and Toxicology, 6020 Innsbruck, Austria

Ca_v1.4 L-type calcium channels characteristically show slow inactivation due to the lack of calcium-dependent inactivation (CDI). This property makes Ca_v1.4 channels appropriate candidates for triggering persistent glutamate release at retinal photoreceptor cell synapses. Mutations in the *CACNA1F* gene encoding for the Ca_v1.4 α_1 subunit are described in patients with X-linked congenital stationary night blindness type 2 (*CSNB2*). Impaired transmission between rod photoreceptor cells and second-order neurons manifests as night blindness and various other visual symptoms in the affected individuals. The aim of this study was to investigate the functional properties of two Ca_v1.4 mutants, such as L849P and R1816stop, compared to wild-type (Wt) in transiently transfected tsA 201 cells ($\beta_3, \alpha_2\delta-1$) via whole-cell voltage-clamp technique using 15 mM Ba²⁺ and Ca²⁺ as charge carrier. Expression of mutant compared to Wt channel protein also analyzed biochemically in Western Blot experiments. For statistics, either Mann-Whitney (two groups) or Kruskal-Wallis test and Dunn's Post hoc test (multiple comparisons) were used. Wt Ca_v1.4 channels showed a very slow recovery from inactivation with a maximal recovery of approx. 90% after 2 min. No significant difference compared to Wt was detected in R1816stop channels. As expected R1816stop, which lacks the distal domain of its intrinsic C-terminal modulator (CTM), exhibited CDI (f-value: WT: 0.05 ± 0.03 (n = 8); R1816stop: 0.57 ± 0.05 (n = 14) p < 0.001) and shifted the voltage-dependence of activation to more negative voltages ($V_{0.5_{act}}$ in mV: WT: 1.4 ± 0.6 (n = 84), R1816stop: -13.2 ± 0.4 (n = 41); p < 0.001; Ca²⁺). In presence of the Ca_v1.4-CTM; comprising the last 122 C-terminal residues WT conditions were fully restored, e.g. $V_{0.5_{act}}$ 2.2 ± 1.0 mV (n = 14). Mutant L849P was mainly characterized by a reduced current density (pA/pF: WT: -13.9 ± 1.0 (n = 84), L849P: -2.5 ± 0.3 (n = 12), p < 0.001; Ca²⁺), only minor, not significant (p > 0.05) changes in the voltage-dependent activation properties were observed. In presence of the dihydropyridine-activator BayK8644 (5 μ M) the current density was increased ~10-fold (p < 0.001). The fold-increase in current density was comparable to WT. We therefore assume that the reduced current density observed in mutant L849P derives from decreased channel expression rather than a reduced open probability. This hypothesis was also supported by a homology model of Ca_v1.4 on the basis on Na_vAB, predicting a folding defect of channel protein which could be manifested either at ER or at plasma transmembrane level. The fact that the functional phenotype of the R1816stop can be rescued might bear a potential pharmacotherapeutic concept based to the C-terminal modulatory mechanism present in Ca_v1.4 channels. Financial support was given by the Austrian Science Fund (FWF, grant P22526 to A.K.).

Modeling the Relations between Neuronal Membrane Potentials, Ion Currents and Ion Channel States

Aubin Tchaptchet, Hans Albert Braun¹

¹Philipps University of Marburg, Institute of Physiology and Pathophysiology, Deutschhastr. 2, 35037 Marburg, Germany

Different types of modeling approaches are used for the examination of neuronal coding and brain dynamics. The physiologically most realistic modeling strategy is the Hodgkin-Huxley type approach [1]. Unfortunately, when facing larger scale problems the original Hodgkin-Huxley (HH)-type algorithms soon become unhandy and even have been considered as “computationally prohibitive” [2].

We present a significantly simplified HH-type modeling approach with focus on actually most relevant experimental and clinical measures [3]. As an example, the complicated and unhandy equations for the calculation of voltage dependent rate constants in the original HH-model have been omitted. Voltage dependencies of (in-)activation time constants can anyhow be neglected. The precise shape of an action potential, nowadays, is of minor interest. Especially, in agreement with conventional presentation of experimental data, the steady state voltage-dependencies of the ionic conductances can be given by easy adjustable Boltzmann functions. Nevertheless, whenever it is required, ion channel rate constants can be considered. These interdependencies, again, can be implemented in a simpler and easy adjustable way, i.e. by single exponential curves with unit values at the half activation voltage of the Boltzmann function.

The figure illustrates these relations by means of teaching tools (www.virtual-physiology.com) that are widely used in medical and other life-science faculties. While the original HH-equations, especially for the rate constants, are difficult to interpret, all curves of the current version are reflecting actual laboratory measures as they are described in conventional physiology textbooks.

Hodgkin and Huxley, 60 years ago (www.cnsorg.org/hodgkin-huxley60), have provided an explanation for action potential generation and conduction in the squid giant axon with exceptional success. However, the main reason for the enormous impact of their work in neurophysiology and beyond was the introduction of a revolutionary new concept that turned out to be physiologically appropriate and extraordinarily flexible for successful adjustment to other tasks, allowing simplifications where possible and extensions whenever required.

References

- [1] Hodgkin A.L. and Huxley A.F. (1952) A quantitative description of membrane current and its application to conduction and excitation in nerve, *J. Physiol.* 17: 500-544
- [2] Izhikevich, E.M. (2003) Simple model of spiking neurons, *IEEE Trans. Neural Netw.*, 14: 1569-1572
- [3] Postnova S., Finke C., Huber M.T., Voigt K., Braun H.A. (2011): Conductance-Based Models of Neurons and Synapses for the Evaluation of Brain Functions, Disorders and Drug Effects. In: *Biosimulation in Biomedical Research, Health Care and Drug Development*. Eds.: E. Mosekilde, O. Sosnovtseva, A. Rostami-Hodjegan. Springer, Wien - New York, pp 93 – 126

Figure: Action potentials (a) based on first order time delays (b) and sigmoid voltage dependencies (c), related exponential voltage dependencies of transition rates (blue) between open and closed states are shown (d). Black dots indicate relative open times (p) at different voltages (V) obtained from 40 ms

simulations runs as shown by examples in (e).

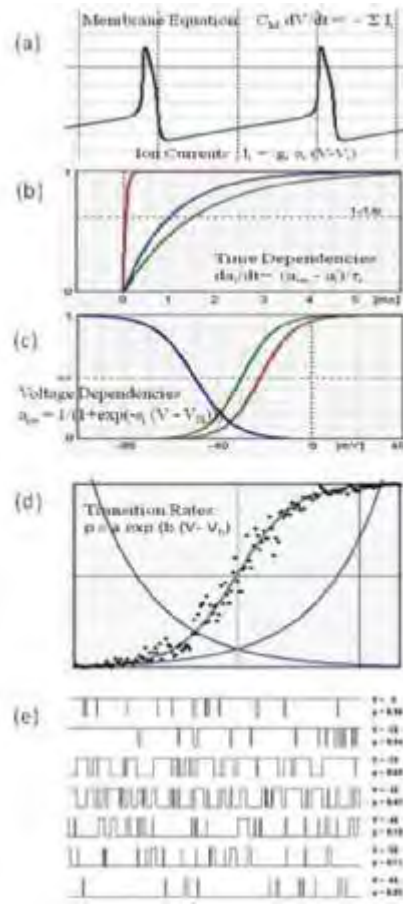

Distribution and Functional Implication of Voltage-Gated Ca²⁺ Channels in the Septohippocampal System

Christina Henseler, Magdalena Elisabeth Siwek¹, Anna Papazoglou¹, Marco Weiergräber¹, Karl Broich¹

¹Bundesinstitut für Arzneimittel und Medizinprodukte, Cellular and Systemic Neurophysiology, Kurt-Georg-Kiesinger-Allee 3, 53175 Bonn, Germany

Highly organized hippocampal theta activity is of central relevance in numerous cognitive and behaviourally related processes. The minimal substrate to induce and maintain theta-activity is the hippocampus and the medial septum-diagonal band of Broca (MS-DBB) with the latter likely to serve as rhythm generator (septal pacemaker – hippocampal follower model). According to the dualistic theory, theta oscillations can be differentiated into atropine-sensitive and atropine-resistant theta activity. Despite intense studies, the molecular and electrophysiological basis of hippocampal theta oscillation is still poorly understood. Voltage-gated Ca²⁺ channels were speculated to be of functional interest, due to their modulation by muscarinic signalling, their complex role in somatodendritic integration, e.g. in hippocampal pyramidal neurons or oscillatory processes in septal and hippocampal GABAergic interneurons. In this study we analyzed the distribution of voltage-gated Cav2.3 and Cav3.2 channels in the murine septohippocampal system using immunohistochemistry, microarray analysis and Real Time Quantitative RT-PCR. Our results provide new insight into the distinct roles of voltage-gated Ca²⁺ channels in septohippocampal rhythmicity.

Loop D of the human Glycine receptor $\alpha 1$ subunit – a susceptible site for mutations associated with Hyperekplexia

Natascha Schaefer, Christoph Kluck², Solveig Schulz³, Carmen Villmann¹

¹Institute for Clinical Neurobiology, AG Villmann, Versbacherstrasse 5, 97078 Wuerzburg, Germany

²Institut fuer Biochemie, Emil-Fischer-Centrum, Friedrich-Alexander-Universitaet Erlangen-Nuernberg

³Zentrum fuer Ambulante Medizin, Universitaetsklinikum Jena, Carl-Zeiss-Platz 8, 07743 Jena

Here we describe three human mutations that are associated with hyperekplexia, a rare neuromotor disease. The underlying cause for hyperekplexia can result from mutations in the postsynaptic glycine receptor (GlyR) $\alpha 1$ subunit, the presynaptic glycine transporter (GlyT2) or from mutations in associated proteins at the inhibitory synapse e.g. glycine receptor β subunit, which is part of the adult receptor complex or gephyrin, the GlyR anchor at the postsynapse.

In humans the first symptoms of hyperekplexia appear right after birth. Affected babies show an extreme startle response after an unexpected stimulus like being touched, changes of light or acoustic stimuli. The affected patients freeze within their actual posture, tremble because of an increasing muscle tone and often experience sudden drops they cannot break. The described symptoms resemble a sub-lethal strychnine poisoning, which hint to the involvement of the strychnine-sensitive inhibitory glycinergic system of the CNS. The inhibitory glycine receptor is predominantly found in the adult spinal cord where it controls the action of motoneurons.

With our clinical cooperation partners we are collecting blood samples from patients suffering from hyperekplexia. We have characterized three point mutations localized in the N-terminus of the GlyR $\alpha 1$ protein, which lead to amino acid exchanges in loop D. Although no crystal structure of the inhibitory glycine receptor exists so far, homology modeling onto the nicotinic acetylcholine receptor revealed a similar organization of the extracellular ligand binding domain. Compared to other members of the same superfamily loop D is not close to the glycine binding site, nor does loop D seem to be part of the known assembly boxes. But the three mutations D70N, W68C and R72H are in direct neighborhood of F63 and R65, which have been described to be important for ligand binding. More over the mouse mutant spasmodic shows an A52S mutation, also resulting in reduced ligand binding.

Using immunocytochemical, electrophysiological and proteinbiochemical methods, we investigate the effects of these mutations on GlyR function in comparison to the wild type GlyR $\alpha 1$. Following transfection of single mutants into the human cell line HEK293, all three mutant proteins were never detected at the cell surface. In turn no glycine-gated channels have been observed in whole-cell patch-clamp recordings. Expression studies in E.coli of the N-terminal domain of three loop-D variants followed by CD spectroscopy, demonstrated no distinct changes compared to wild type $\alpha 1$. Recently, we could show, that recessive hyperekplexia lead to less stable proteins and an ER-associated proteosomal degradation. In ongoing experiments the mutant variants are followed during assembly and transport. We concentrate on subcellular compartments as the ER-Golgi intermediate compartment, early and late Golgi compartment. Finally, the degradation pathway will be defined by blocking experiments. These data will help to understand the pathomechanism of hyperekplexia.

Reduced hippocampal GABAergic activity in a low birth weight rat model of depression

Zita Dosa, Jose Luis Nieto-Gonzalez¹, Betina Elfving², Karin S. Hougaard³, Mai M. Holm¹, Gregers Wegener^{2,4}, Kimmo Jensen^{1,5}

¹Synaptic Physiology Laboratory, Department of Biomedicine, Aarhus University, Aarhus, Denmark

²Center for Psychiatric Research, Aarhus University Hospital, Risskov, Denmark

³National Research Centre for the Working Environment, Copenhagen, Denmark

⁴Unit for Drug Research and Development, School of Pharmacy (Pharmacology), North-West University, Potchefstroom, South Africa

⁵The Lundbeck Foundation Research Center MIND, Department of Biomedicine, Aarhus University, Aarhus, Denmark

Background: Epidemiological studies have shown that low birth weight (LBW) increases the risk of developing neuropsychiatric disorders, such as depression in later life. Adverse genetic and environmental impact during early development, such as glucocorticoid hyper-exposure can lead to lower body size at birth. In a LBW rat model of depression, Sprague Dawley rats were exposed to dexamethasone, a synthetic glucocorticoid during the last week of fetal life. These rats have a low body weight at birth, and show depressive-like behavior in adulthood.

Aim: As the GABAergic inhibitory system is proposed to be involved in the pathophysiology of depression, the aim of the study was to examine the electrophysiology of GABAergic inhibition in the hippocampus of LBW rats.

Methods: Whole-cell patch-clamp recordings were performed from dentate granule cells of brain slices to examine GABA_A receptor mediated phasic and tonic inhibition.

Results: In young adult (4-week-old) rats, a significant decrease in the frequency of spontaneous inhibitory postsynaptic currents (IPSCs) was observed, while action potential independent miniature IPSCs were unchanged. With respect to IPSCs evoked by extracellular paired-pulse stimulation, in LBW rats, we observed a significantly higher paired-pulse ratio in 4-week-old rats compared to controls (LBW: 1.14 ± 0.126 , $n = 14$; control: 0.8 ± 0.042 , $n = 9$; $P < 0.05$, Figure). Extrasynaptic GABA_A receptor mediated tonic current showed no significant difference in LBW rats.

Conclusion: Our results demonstrate a dysfunction in the limbic GABAergic inhibitory system in LBW rats, which may contribute to the pathophysiology of depressive-like behavior in adulthood.

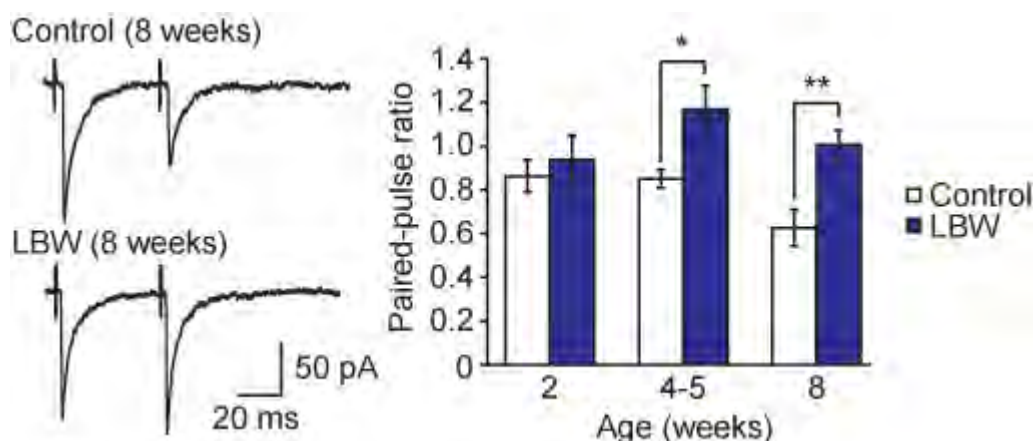

N- and C-termini of ASIC4 direct the channel into early endosomes

Katharina Friedrich, Georg Polleichtner¹, Stefan Gründer¹

¹UK Aachen, RWTH Aachen, Institute of Physiology, Pauwelsstraße 30, 52074 Aachen, Germany

Acid-sensing ion channels (ASIC) are voltage-independent proton-gated Na⁺ channels belonging to the DEG/ENaC superfamily. ASIC4 is a member of the ASIC family that is mainly expressed in the central nervous system with strong localization in the pituitary gland. It is not activated by a drop in extracellular pH and its function is still unknown.

In this study we investigated the subcellular localization and targeting of ASIC4. When transiently expressed in Cos7 or HEK293 cells, GFP-tagged ASIC4 accumulated in small vesicles in the cell. To identify the exact localization we stained the cells with fluorescent organelle markers and antibodies for examination with fluorescence microscopy. ASIC4 showed a colocalization with Rab5, a marker for early endosomes.

We then set out to identify the trafficking signals, which are responsible for the targeting of ASIC4 into early endosomes. ASICs have two transmembrane domains and intracellular amino- and carboxy-termini. We constructed ASIC4 mutants with truncated C- and N-termini, chimeras with the C- and N-termini of ASIC2a, an ASIC with a predominant location in the ER, and point mutations of di-leucine and di-arginine motifs at the termini, which are known trafficking signals. Our results revealed that both intracellular termini of ASIC4 influence its distribution.

Most of the truncated ASIC4 mutants and the chimeras mainly distributed in different intracellular compartments than ASIC4 wild type, most likely the ER. Especially the first 18 aminoacids at the N-terminus and a di-arginine motif on position 478 at the C-terminus seem to play an important role for the targeting of ASIC4 into early endosomes. Ongoing studies showed that the truncation of the C-terminus including the mentioned diarginine motif directed the channel into a third compartment, different from early endosomes and the ER. This suggests different roles of the amino- and the carboxy-termini for the targeting of ASIC4 that we are currently examining in more detail.

The ASIC4 point mutations of two di-leucine motifs on position 29 at the N-terminus and on position 519 at the C-terminus accumulated in vesicles, similar to ASIC4 wild type, showing that di-leucine motifs have apparently no role in trafficking of ASIC4.

In summary, our results identify trafficking signals at the amino- and carboxy-termini of ASIC4 directing the channel into early endosomes, suggesting that ASIC4 may have a role in this intracellular compartment.

Inter-subunit disulfide bond formation indicates P2X3 receptor ectodomain movement

Maria Kowalski, Peter Illes¹, Thomas Riedel¹

¹Universität Leipzig, Rudolf-Boehm-Institut für Pharmakologie und Toxikologie, Härtelstraße 16-18, 04107 Leipzig, Germany

The trimeric P2X3 receptor (P2X3R) is an ATP-gated ion channel, situated on sensory neurons such as dorsal root ganglia, and is involved mostly in pain sensation. In order to develop selective ligands as possible therapeutic agents, it is important to gather detailed knowledge about the receptor structure and function. Based on the published zebrafish (z)P2X4R crystal structure, we generated a homology model of the human (h)P2X3R. This model indicates movement within the ectodomain near the ATP binding pouch, whereby two neighbouring receptor subunits approach each other. To prove the hypothesis of a potential relevance of this movement for receptor behaviour, we used a mutagenesis-based approach, by creating cysteine mutants of the (h)P2X3R and expressing them in HEK293 cells.

By introducing two opposing cysteine residues at the supposed contact sites, we intended to enable the formation of a disulfide bond resulting in immobilization of the receptor in one state of operation. Therefore, we generated two different sets of cysteine double-mutants cross-linking adjacent receptor subunits at two varying positions via an inter-subunit disulfide bond. The influence of the inserted disulfide bonds on the functional consequences of ATP binding was measured by whole-cell patch clamp technique.

Within each set of cysteine mutants forming disulfide bonds we could identify one cysteine double-mutant showing an almost complete abolition of receptor functionality. In a second step, we restored the receptor mobility by reversing the disulfide bond formation using the reducing agent dithiothreitol (DTT). The application of DTT resulted in 8 to 14-fold increased currents compared to the non-reduced state, followed by a current decline after DTT washout.

In conclusion, the predicted receptor movement was confirmed by experimental results. We suggest that the inter-subunit disulfide bond either might prevent ATP binding in the nearby agonist binding pouch or affect the conformational change required for ion channel opening.

Differential expression of hyperpolarization-activated cyclic nucleotide gated channel isoforms (HCN1–4) in neocortical tissues from patients with temporal lobe epilepsy

Stephan Wierschke, Peter Horn², Christoph Dehnicke³, Anja U Bräuer¹, Rudolf A Deisz¹

¹Charité Universitätsmedizin Berlin, Center for Anatomy, Institute for Cell Biology and Neurobiology ²Charité Universitätsmedizin Berlin, Department for Neurosurgery

³Evangelisches Krankenhaus Königin Elisabeth Herzberge, Epilepsie-Zentrum Berlin-Brandenburg

Background: Hyperpolarization -activated cyclic nucleotide gated channels (HCN channels) crucially regulate the excitability of central neurons and have been implicated in epileptogenesis: in particular the fast gating isoform HCN1. HCN1 knock-out mice show an increased susceptibility to the convulsant kainate¹. In the hippocampus of rats, status epilepticus induced by pilocarpine entails a reduced HCN1 mRNA expression² or a misdirected trafficking of the HCN1 protein³ after kainate-induced status epilepticus. The alterations in human focal epilepsies are controversial. In neocortical tissues from patients with temporal lobe epilepsy (TLE) we reported a reduced density of the HCN-channel mediated cation current I_h in cases with higher seizure frequencies⁴. However, recent studies on the dentate gyrus revealed an increase in I_h and HCN1 expression in TLE with hippocampus sclerosis^{5,6}.

Methods: To elucidate the mechanisms underlying the deficits of neocortical I_h in TLE, we measured the I_h density (see⁴) and mRNA levels of the subunits HCN1–4 using quantitative RT-PCR with multiple reference gene normalization⁷. TLE tissues were segregated into two groups based on the frequency of complex partial seizures (CPS) and secondary generalized tonic-clonic seizures (GM): (i) Tissues from patients suffering “few” seizures <1 GM and <104 CPS per year (4 female, 8 male; age: 38.6 ± 18.5 years; mean ± SD) and, (ii) from patients with “many” seizures >1 GM or >104 CPS per year (6 female, 5 male; age: 34.7 ± 11.2 years). Age-matched *post mortem* control tissues (3 female, 8 male; age: 40.0 ± 10.3 years; PMD on average 6.7 h, range: 2–14 h) from temporal lobe neocortex without neurological findings were used for comparison of mRNA levels (kindly provided by the BrainNet Europe Consortium).

Results: Compared to controls (n=11), the HCN1 mRNA was significantly reduced in TLE tissues, by 40.6 % in tissues with “few” seizures (n=10; p<0.01) and by 48.3 % in tissues with “many” seizures (n=11; p<0.001). The HCN2 and HCN3 mRNA levels were indistinguishable between the three groups (p>0.05). The HCN4 mRNA, however, was increased by 147.6 % in tissues with “few” seizures (p<0.05) and by 125.5% in tissues with “many” seizures (p<0.01). Between the two TLE groups there were no significant differences in the HCN1 or HCN4 mRNA levels despite differences in the average I_h densities in these tissues (“few” seizures: 3.3 ± 0.9 pA/pF; “many” seizures: 2.5 ± 0.5 pA/pF; p<0.05).

Discussion: The observed reduction of HCN1 mRNA in TLE tissues compared to *post mortem* controls is in line with findings from the hippocampus (CA1) of pilocarpine-treated rats² but in contrast to findings from the dentate gyrus of TLE patients^{5,6}. The increased expression of HCN4, also found in the dentate gyrus of pilocarpine -treated rats⁵, might represent a compensatory albeit insufficient mechanism considering the slower gating of HCN4 vs. HCN1 channels. Our data suggest that transcriptional mechanisms contribute to different I_h densities in TLE tissues. Whether these changes account for

differences in protein levels and function remains to be tested.

References

1. Huang Z *et al.* 2009, J Neurosci 29: 10979–10988.
2. Jung S *et al.* 2011, J Neurosci 31: 14291–14295.
3. Shin M *et al.* 2008, Neurobiol Dis 32: 26–36.
4. Wierschke S *et al.* 2010, Epilepsia 51: 404–414.
5. Surges R *et al.* 2012, Biochem Biophys Res Commun 420: 156–160.
6. Stegen M *et al.* 2011, Cereb Cortex 22: 2087–2101.
7. Wierschke S *et al.* 2010, Biochem Biophys Res Commun 403: 385–390.

Ca²⁺ channel promiscuity of small conductance Ca²⁺-activated K⁺ channels (SK) in hippocampal pyramidal neurons

Felix Benninger, Shmuel Chen², Yoel Yaari^{2,3}

¹Rabin Medical Center, Campus Beilinson, Neurology, Jabotinsky, 49100 Petach Tikva, Israel

²Department of Medical Neurobiology, Institute for Medical Research Israel-Canada, The Hebrew University School of Medicine, Jerusalem, Israel

³The Interdisciplinary Center for Neuronal Computation, The Hebrew University, Jerusalem, Israel

Most types of CNS neurons decrease their firing rate during prolonged excitation, a phenomenon referred to as spike frequency adaptation (SFA). In most cases SFA is caused by activation of slow K⁺ conductances. In CA1 pyramidal cells, early SFA is mediated predominantly by perisomatic, low voltage-activated M-type K⁺ current, but when this current is compromised, perisomatic, apamin-sensitive SK channels become crucial in SFA. These channels are activated by spike Ca²⁺ entry via voltage-sensitive Ca²⁺ channels (VSCCs). Because these neurons express multiple subtypes of VSCCs, which may be differentially activated during repetitive discharge, the question arises whether SK channels are selectively coupled to a subset of these channel subtypes, as is the case in several other types of neurons (e.g., coupling of SK channels to P/Q-subtype VSCCs in cerebellar Purkinje neurons). Here, we have attempted to identify the VSCC subtype/s that activate perisomatic SK channels in CA1 pyramidal cells using voltage- and current-clamp recordings in acute hippocampal slices. SK current amplitudes were equally reduced by selective blockers of T/R-, L-, N- or P/Q-subtypes of VSCCs. Total block of SK current was achieved only by applying a mixture of all blockers. When neurons were filled with the fast Ca²⁺ chelator BAPTA, SK currents were eliminated entirely, indicating that SK channels are separated from the VSCCs. Filling neurons with the slow Ca²⁺ chelator EGTA caused reduction in SK current, but did not introduce selectivity for certain VSCC subtypes. Congruently, in current-clamp recordings in slices treated with XE991 to block M-channels, blocking individual subtypes of VSCCs had no notable effect on neuronal firing, whereas blocking all subtypes caused a prolonged burst followed by plateau depolarization. We conclude that in CA1 pyramidal cells, perisomatic SK channels contributing to SFA are promiscuously coupled to all subtypes of VSCCs.

Differential regulation of chloride transporter expression by bioelectric activity in chicken auditory brainstem *in vitro*

Marcus Joseph Wirth, Desirée Kupsch¹, Julia Krebbers^{1,2}, Hermann Wagner³

¹RWTH Aachen, Biologie 2 - Zoologie und Tierphysiologie, Lukasstrasse 1, 52070 Aachen, Germany

²Heinrich Heine Universität Düsseldorf, Molecular Neurobiology - Neurological Clinic, Moorenstraße 5, 40225 Düsseldorf

³RWTH Aachen, Biologie 2 - Zoologie und Tierphysiologie, Mies-van-der-Rohe-Str. 15, 52074 Aachen, Germany

Neurons in the auditory brainstem of chicken maintain an elevated chloride reversal potential even after hatching and show a depolarising effect of GABA. The GABAergic input to *Nucleus laminaris* (NL) and *Nucleus magnocellularis* (NM) from the *Nucleus olivaris superior* (SON) elicits a depolarisation, but is inhibitory due to shunting inhibition. The physiological relevance of this effect is to increase the accuracy of sound localization. Important regulators of chloride homeostasis are the transporters of the SLC12 family. It is likely that a differential activity of the inward directed sodium-potassium-chloride-cotransporter 1 (NKCC1) and the outward directed potassium-chloride-cotransporter 2 (KCC2) is responsible for the maintenance of the elevated reversal potential.

Our previous studies *in vivo* showed an expression of the inward transporter NKCC1 and the outward transporter KCC2 in neurons of NM and NL whereas the outward transporter KCC4 (potassium-chloride-co-transporter 4) is expressed exclusively in surrounding glia cells.

To analyze the regulation of the expression of chloride transporters, organotypic cultures have been prepared by the roller-tube technique (Gähwiler, 1981). Auditory brainstem was explanted at embryonic day 10 and kept *in vitro* for 7 days. Afterwards, immunofluorescent stainings against NKCC1, KCC2, and KCC4 together with glial as well as neuronal markers were performed. NKCC1 and KCC2 expression patterns are comparable to *in vivo* at embryonic day 18, although the level of bioelectric activity should be low due to the lack of the basilar papillae in these cultures. However, in contrast to *in vivo*, NKCC1 is localized more in the cytosolic compartment. To our surprise, the expression of KCC4 in glial cells surrounding the auditory nuclei was low. In cultures treated with 25 mM potassium chloride to increase the bioelectric activity, the expression of NKCC1 and KCC2 is largely unchanged. In detail, the localization of NKCC1 shifts to the membrane whereas KCC2 is now localized more in the cytosolic compartment. Unexpectedly, we now found a strong ectopic expression of KCC4 in auditory neurons additional to the glial expression.

Our data suggest some activity-dependent regulation of the chloride transporters analyzed.

Modulatory effect of histamine on ligand-gated ion channels

Ulrike Thiel, Philipp Lorenz¹, Olaf Kletke², Hanns Hatt¹, Günter Gisselmann¹

¹Ruhr University, Cell Physiological, Universitätsstrasse 150, 44801 Bochum, Germany²University Düsseldorf, UKD, Neuro- and sensory physiology, Universitätsstrasse 1, 40225 Düsseldorf, Germany

γ -Aminobutyric acid (GABA) is the most important inhibitory neurotransmitter in the mammalian brain, which regulates excitability in neuronal circuitries mainly through the fast ionotropic GABA_A receptors (GABA_ARs), heteropentameric proteins constructed from subunits derived from several related gene families. Subunit combinations are restricted in their number with the $\alpha 1\beta 2\gamma 2$ receptor-type being dominant in the brain (ca 60% of total brain GABA_ARs) followed by the $\alpha 2\beta 2/3\gamma 2$ receptor-type (ca 15%). Native receptors may contain two different β - and two different α -subunits co-assembled in one receptor, providing large heterogeneity of native GABA_ARs. Positive allosteric modulators of GABA_ARs are of high clinical importance as anxiolytics, anesthetics and sedatives. In total, the GABA_AR incorporates more than ten distinct modulatory binding sites targeted by anticonvulsive, antiepileptic, sedative, hypnotic and anxiolytic compounds belonging to chemically different structural classes. Recently, it has been shown that histamine is modulator and activator of GABA_ARs. Histamine mediates many physiological functions in the periphery and it is an important neurotransmitter in the brain. It is known that histamine acts on peripheral metabotropic H₁-H₄ receptors mediating vasodilation, bronchoconstriction and stimulation of gastric acid secretion. In the brain it is involved in sleep control through tuberomammillary nucleus neurons. In this study we investigated the effect of histamine on recombinant ion channels. We characterized several GABA_A and glycine receptors, constructed several point mutations as well as chimeras between GABA_A and glycine receptors. We expressed different channel subunits in *Xenopus laevis* oocytes and characterized the effect of histamine using the two electrode voltage clamp technique.

Alterations in input resistance, spike threshold and firing properties of layers 2/3 pyramidal neurons following focal laser lesions in the rat visual cortex

Barbara Imbrosci, Thomas Mittmann¹

¹University of Mainz, Institute of physiology and pathophysiology, Duesbergweg 6, D-55128 Mainz, Germany

Focal cortical injuries are often followed by alterations in the activity and function of the surviving neuronal networks. Previous studies suggested that this altered excitability arises from an unbalance between excitation and inhibition. Potential alterations in the intrinsic excitability of single cortical neurons received less attention instead. In the present study we used a well established in vivo- ex vivo model of infrared-laser lesion in the visual cortex of rats to explore the effect of the injury on the intrinsic functional properties of surviving layers 2/3 pyramidal neurons located at 1 and 2 mm lateral from the lesion border. All recordings have been performed in acute cortical slices prepared between the second to the fifth post-operative day. In order to recreate, at least to some extent, the high ongoing background activity found in vivo, cortical slices were perfused with an artificial cerebrospinal fluid (ACSF) slightly different in ionic composition from a standard perfusing medium. Remarkably, recent studies, using such “modified ACSF” (mACSF), were able to observe high neuronal activity in otherwise silent brain slices. This suggests that the usage of a mACSF constitutes a valid tool to reduce the gap between data obtained in vitro and in vivo. Interestingly, under these experimental conditions, we observed lesion-induced changes in input resistance, spike threshold as well as in the firing behavior of layers 2/3 pyramidal neurons. These changes were most likely unmasked by the usage of the mACSF since a recent paper from our laboratory failed to detect such changes when a standard ACSF was used. Our findings suggest that alterations in neuronal intrinsic properties, which have so far been underestimated, may have a great impact into the pathophysiological processes following brain injuries. Furthermore our data provide evidence that exciting “acute brain slices” with a mACSF might unmask physiological alterations otherwise not detectable in quiescent brain slices.

Hippocampal vesicular GABA transporters as targets for *in vivo* labelling of inhibitory synapses and immunolesioning of GABAergic neurons

Wolfgang Härtig, Alán Alpár², Flavia Antonucci³, Johannes Kacza⁴, Claudia Verderio³, Henrik Martens⁵, Jens Grosche¹, Dominik Michalski⁶, Michela Matteoli³, Tibor Harkany²

¹University of Leipzig, Paul Flechsig Institute for Brain Research, Pathophysiology of Neuroglia, Jahnallee 59, 04109 Leipzig, Germany,

²Karolinska Institutet, Division of Molecular Neurobiology, Stockholm, Sweden,

³University of Milan, CNR Institute of Neuroscience, Department of Medical Pharmacology, Milan, Italy,

⁴University of Leipzig, Institute of Anatomy, Histology and Embryology, Leipzig, Germany,

⁵Synaptic Systems, Göttingen, Germany,

⁶University of Leipzig, Department of Neurology, Leipzig, Germany

GABAergic inhibitory interneurons in the hippocampus and cerebral cortex control global firing rates by coordinating the activity of excitatory neurons along short time scales. The dysfunctional temporal activity of hippocampal interneurons is involved in the generation of epileptiform seizures and behavioural changes. Therefore, experimental tools selectively addressing the GABAergic system are of interest and could facilitate the elucidation of the underlying pathophysiology. However, such promising tools are still limited.

Here, we present data on a novel concept for selective targeting the vesicular GABA transporter, also known as vesicular inhibitory amino acid transporter (VIAAT) that loads GABA (or glycine) into synaptic vesicles at axonal endings. Recently, we found that this transporter displays a unique and unexpected topology, e.g., its C-terminus is located in the lumen of vesicles (Martens et al. 2008, J. Neurosci. 28: 13125-13131). We postulated that during transmitter release, when intraluminal epitopes are shortly exposed to the extracellular space, experimentally applied antibodies might bind VGAT-C followed by their internalisation. Three days after injection of carbocyanine (Cy)3- or Oyster550-tagged anti-VGAT-C conjugates into hippocampi of mice, we observed a red fluorescent labelling of GABAergic synapses *in vivo*. The specificity of the bright signal was confirmed by series of counterstaining, for instance involving glutamate decarboxylase (GAD) as marker enzyme for GABAergic neurons and parvalbumin occurring in fast-firing inhibitory neurons.

In a second set of experiments using mice and rats, the selective elimination of GABAergic interneurons was achieved by immunolesion after intrahippocampal immunotoxin injection (Antonucci, Alpár et al. 2012, J. Neurosci. 32: 1989-2001). Thereby, we used novel saporin-conjugated anti-vesicular GABA transporter antibodies (SAVAs), prepared by coupling the ribosome-inactivating protein saporin (from *Saponaria officinalis*) and antibodies against VGAT-C *via* a bifunctional cross-linker, followed by several purification steps mainly removing free saporin and unconjugated antibodies. Twelve days after unilateral injection of SAVAs, we were able to demonstrate the selective loss of GABAergic neurons and synapses by immunoperoxidase and immunofluorescence labelling of GAD and parvalbumin. Furthermore, other GABAergic subpopulations such as somatostatin and neuropeptide Y (NPY)-immunoreactive interneurons were also eliminated, confirming the efficacy of applied SAVAs. Ultrastructural analysis revealed degenerating parvalbumin-containing perikarya as exemplified for the immunolesioned dentate gyrus. On the other hand, glutamatergic, vesicular glutamate transporter (VGLUT)1-immunopositive

afferents appeared preserved 12 days and even 10 weeks after immunolesion.

The presented data identify SAVAs as a versatile tool to further investigate the role of GABAergic neurons to a broad range of neuronal circuits whose manipulation can recapitulate the underlying pathophysiological cascades of diseases like epilepsy, probably schizophrenia and other neuropsychiatric diseases.

Immunocytochemical and electrophysiological characterization of GFP-expressing GABAergic interneurons of the adult mouse cingulate cortex

Maria-Therese Riedemann, Bernd Sutor¹

¹Institute of Physiology, Physiological Genomics, Schillerstrasse 46, 80336 Muenchen, Germany

GIN mice are transgenic animals expressing EGFP in a subpopulation of GABAergic interneurons [1]. In the hippocampus and somatosensory cortex, these cells have been classified as somatostatin-expressing, regular -firing interneurons. In the somatosensory cortex, these cells were found predominantly in layer 2 and 3, but also in the deeper layers of the neocortex. We investigated the immunocytochemical and electrophysiological properties of these neurons in the mouse anterior and medial cingulate cortex.

All mice used in this study were older than four weeks. Immunocytochemistry was performed on 50- μ m-thick coronal brain sections. Cells were stained for GFP as well as somatostatin. The distribution of these GFP-expressing cells was analyzed in a volume of 0.018 mm³, comprising layer 1 – 6. Confocal pictures were taken with the Zeiss LSM710 laser scanning microscope using the ZEN software. The total cell number was assessed by DAPI staining. Colocalization of somatostatin and GFP was investigated in a volume of 0.006 mm³ of cortical layers 2 and 3. Electrophysiological experiments were performed in vitro using coronal slices (300 μ m thick) prepared from the cingulate cortex of GIN mice. Whole-cell patch clamp recordings were taken from fluorescent neurons located in layers 2 and 3.

Immunocytochemical analysis revealed that almost 90 % of the GFP-expressing cells were found to be located in layer 2 and 3. The remaining cells were randomly dispersed across the other layers. Altogether, GFP-expressing cells accounted for only 1 – 2 % of the total cell population. The vast majority (more than 80 %) of these interneurons, but not all of them, also expressed somatostatin. In addition, a significant population of somatostatin-positive but GFP-negative cells has been identified in deeper but also in superficial layers of the cingulate cortex. Cells expressing only somatostatin made up 2 – 3 % of the total cell population.

For electrophysiological recordings, fluorescent neurons with a polygonal to spherical shape of the soma were chosen. The resting membrane potential of these neurons ranged between -65 and -70 mV and the input resistance between 300 - 550 MO. The current-voltage relationship was characterized by inward rectification in both, the depolarizing and hyperpolarizing direction. The amplitude and duration of current-induced action potentials were found to be 80 – 90 mV and 0.7 – 1 ms, respectively. Each action potential was followed by a fast and short-lasting afterhyperpolarization. Upon injection of long-lasting (1 – 4 s) suprathreshold depolarizing currents steps, two discharge patterns were observed: (1) repetitive firing with a high initial frequency, a steadily declining interspike interval (so-called regular -spiking pattern associated with spike adaptation), and a relatively high trial-to-trial reproducibility, (2) repetitive firing with a high initial frequency, with irregularly occurring pauses of variable duration (up to 1 s), and a low trial-to-trial reproducibility. Application of low concentrations of tetraethylammonium chloride (TEA, 1 or 3 mM) led to a block of the fast spike afterhyperpolarization, a prolongation of action potential duration and an inhibition of the irregular, long-lasting interspike intervals. Voltage-clamp recordings revealed TEA-induced significant reductions of outward currents activated around -40 mV.

In conclusion: our immunocytochemical results suggest a relatively homogeneous population of GFP- and somatostatin-expressing neurons in the cingulate cortex of GIN mice. However, electrophysiological recordings revealed at least two subgroups distinguished by their discharge behavior and, probably, by their potassium channel expression.

[1] Oliva AA et al., J. Neurosci. 20: 3354, 2000

Activation of glycine receptors modulates spontaneous epileptiform activity in the immature rat hippocampus

Rongqing Chen, Akihito Okabe², Haiyan Sun¹, Salim Sharopov¹, Sergei N. Kolbaev¹, Ileana L. Hanganu-Opatz³, Atsuo Fukuda⁴, Heiko J. Luhmann¹, Werner Kilb¹

¹Johannes Gutenberg-University, Institute of Physiology and Pathophysiology, Duesbergweg 6, D-55128 Mainz, Germany

²Department of Molecular Anatomy, School of Medicine, University of the Ryukyus, 207 Uehara, Nishihara, Okinawa 903-0215, Japan

³Center for Molecular Neurobiology, University Medical Center Hamburg-Eppendorf, Falkenried 94, D-20251 Hamburg, Germany

⁴Department of Physiology, Hamamatsu University School of Medicine, Hamamatsu, Shizuoka 431-3192, Japan

Activation of glycine receptors promotes an anticonvulsant effect in the adult hippocampus. Since the glycinergic system plays a particularly important role during early cortical development, when glycine receptors mediate depolarizing membrane responses, we addressed the question whether an activation of glycine receptors mediate pro- or anticonvulsive effects in the immature hippocampus. Therefore we examined the effect of glycinergic agonists and antagonists in the CA3 region of an intact corticohippocampal preparation of the immature (postnatal day 4-7) rat using field potential recordings. Bath application of the glycinergic antagonist strychnine (0.5-3 μ M) induced epileptiform discharges, suggesting that glycine receptors contribute to the inhibitory tone preventing excess excitation. In accordance with this suggestion, bath application of glycine (100 μ M) or glycinergic agonists taurine (= 1 mM) attenuated recurrent epileptiform activity induced by 20 μ M 4AP in low-Mg²⁺ solution. Because taurine is a partial agonist of GABA_A receptors, we also investigated the effect of taurine in the presence of the GABA_A antagonist gabazine. The anticonvulsive effect of taurine maintained in the presence of gabazine and was attenuated by 3 μ M strychnine, suggesting that it was partially mediated by glycine receptors. In contrast to this stable anticonvulsant effect of higher glycine and taurine concentrations, we observed that bath application of 10 μ M glycine or 100 μ M taurine enhanced the occurrence of recurrent epileptiform discharges. This proconvulsive effect was prevented in the presence of 3 μ M strychnine, suggesting that it directly depends on glycine receptor activation. In order to investigate whether a glycinergic membrane depolarization is required for these proconvulsive effects or low glycine and taurine concentrations, we inhibited the active NKCC1-dependent Cl⁻ accumulation with the loop diuretic bumetanide (10 μ M). These experiments revealed that the proconvulsive effect of glycine and taurine was completely abolished under this condition, suggesting that it directly depends on depolarizing membrane responses. In summary, we conclude from these results that in the immature hippocampus activation of glycine receptors can mediate both pro- and anticonvulsive effects, but that a persistent activation of glycine receptors is required to suppress epileptiform activity.

Optochemical control of genetically engineered glutamate and acetylcholine receptors in *C. elegans*

Jatin Nagpal, Jana Liewald¹, Tatsuya Urushima², Dirk Trauner², Alexander Gottschalk¹

¹Buchmann Institute for Molecular Life Sciences, Goethe University, Frankfurt, Germany.

²Department of Chemistry, Ludwig Maximilians University, Munich, Germany.

Optical control of neural activity using ChR2 and other microbial rhodopsins is highly useful, yet does not allow accurate localized control of membrane potential, as these tools diffuse along the plasma membrane. For 'natural' depolarization, endogenous ion channels were rendered photoactivatable using photoswitchable tethered ligands (Szobota et al, 2007). We aim to establish light activated glutamate and nicotinic acetylcholine receptors (LiGluR and LiAChR, respectively) as novel optochemical genetic tools in *C. elegans*.

Locomotion command interneurons integrate sensory information likely by glutamatergic innervation, thus a LiGluR expressed in these cells would enable to better understand sensory transduction. We introduced cysteines in putative *C. elegans* kainate (KA-) receptors, in positions analogous to those used in the original LiGluR (i.e. rat iGluR6), in the clamshell ligand binding domain. The photoactivatable tethered ligand maleimide-azobenzene-glutamate (MAG) is covalently linked to these cysteines, allowing the receptor to be photoswitched. KA-receptor cysteine mutants were expressed in muscles and the animals incubated with MAG. First attempts to photodepolarize the muscle cells were only mildly positive. We now are expressing *C. elegans* kainate (KA-) receptor in their native neuron environment to provide the accessory subunit support which may be required for functional expression of the receptor on the plasma membrane of the cell.

The in vivo function of the homomeric nAChR consisting of ACR-16 subunits is poorly understood. Deletion of *acr-16* causes strong reduction of neuromuscular junction (NMJ) currents in response to ACh, however no behavioral defects are apparent in *acr-16* mutants. Hence for analyzing NMJ function in vivo, LiAChR would be a useful tool. We generated several cysteine mutants based on sequence alignments and modelling of ACR-16 onto the structure of ACh binding protein. Functionality of the mutated proteins is assessed by mutant rescue and electrophysiology. Photoswitching will be achieved with a novel carbachol containing ligand, MAC, or with MACh, containing ACh.

Suppression of HCN channel-mediated current (I_h) in forebrain neurons impairs early postnatal sensorimotor development and alters neonatal cortical network activity

Andrea Merseburg, Anna Katharina Schlusche¹, Stephan Marguet¹, Jasper Grendel¹, Zhuo Huang², Mala Shah², Fabio Morellini¹, Dirk Isbrandt¹

¹Zentrum für Molekulare Neurobiologie Hamburg, DFG Heisenberg Team: Experimental Neuropediatrics, Falkenried 94, 20251 Hamburg, Germany

²Dept. of Pharmacology, School of Pharmacy, University of London, U.K.

Oscillations in the central nervous system result from a delicate interplay of individual neurons. The intrinsic properties of neurons are greatly influenced and determined by the expression of different ion channels. Changes in the expression and/or function of ion channels can affect oscillatory properties of individual neurons and neuronal populations and, as a consequence, behavior. The developing brain is especially vulnerable to perturbations in neuronal properties and function. Here, we investigate whether the H-current, which is mediated by hyperpolarization-activated cyclic nucleotide-gated, non-selective cation (HCN) channels, plays a role in central nervous system (CNS) development. Given that HCN channels are expressed as early as embryonic day 15, we sought to investigate the contribution of I_h -deficiency to prenatal and early postnatal development of the CNS.

Suppression of HCN-channel activity in projection neurons of the murine forebrain was achieved via a dominant-negative HCN subunit (HCN4DN) conditionally expressed under control of the calcium-calmodulin dependent kinase II (CaMKII) promoter.

Transgene expression resulted in the suppression of endogenous H-currents and in enhanced dendritic and somatic excitability of CA1 pyramidal cells and entorhinal cortex (EC) layer III stellate cells *in vitro*.

To monitor early postnatal development, we assessed the sensorimotor reflexes of neonatal mice. Early *in vivo* network activity in the hippocampus and primary visual (V1) cortex of 7-day-old awake pups was recorded using 16-channel linear silicon probes. In adult mice, we investigated learning and memory abilities and *in vivo* hippocampal network activity in chronically implanted animals.

We found that the development of sensorimotor reflexes of neonatal I_h -deficient mice was impaired. Loss of forebrain HCN-channel function resulted in a reduced rate of slow activity transients (SATs) and spindle bursts (SB) in the V1 cortex. In contrast, early hippocampal network activity was not significantly affected. Adult mutant mice showed persistent deficits in learning and memory tasks, and preliminary results of sleep recordings suggest changes in sharp wave/ripple properties during non-REM sleep, as well as alterations in theta (4-10 Hz) and gamma (30-100Hz) oscillations during REM sleep.

In summary, forebrain-specific loss of HCN-channel function impairs early postnatal development with long-term effects in adult mutant mice.

Dual function of TRPM8 as an ion channel and G protein-activating receptor

Christian Wetzel

¹Universität Regensburg, Lehrstuhl für Psychiatrie und Psychotherapie, Universitätsstr. 84, 93053 Regensburg, Germany

The transient receptor potential (TRP) family of ion channels comprises receptors that are activated and regulated by a vast variety of physical as well as chemical stimuli. TRP channels interact in a complex manner with several intracellular signalling cascades, both up- and downstream of receptor activation. A huge variety of mechanisms lead to the activation of TRP channels which then communicate their signal into the cell by gating ion fluxes through their intrinsic pores. In the present study, we set out to investigate the downstream signalling pathways triggered by stimulation of TRP channels and investigated the direct or indirect impact of TRP channel signalling on intracellular metabotropic cascades. We found evidence for both, a functional and structural interaction of TRPM8 with Gαq in a heterologous expression system. We demonstrated a menthol-evoked increase in intracellular Ca²⁺ under extracellular Ca²⁺-free conditions, which was blocked by the PLC inhibitors U73122 or edelfosine. This metabotropic Ca²⁺ signal could also be mediated by a channel-dead (i.e. non-conducting; V976D) or chloride-conducting TRPM8 pore mutant (V976K). The intracellular metabotropic Ca²⁺ signal was absent in Gαq deficient cells or in the presence of dominant-negative GαqX. Evidence for physical interaction of TRPM8 and Gαq was provided by acceptor bleaching experiments demonstrating FRET (Förster resonance energy transfer) between TRPM8-CFP and Gαq-YFP. In addition, a Gαq-YFP mobility assay (fluorescence recovery after photobleaching, FRAP) revealed a restricted diffusion of Gαq-YFP under conditions when TRPM8 is immobilized in the plasma membrane. Further FRET experiments with cytosolic TRPM8 fragments indicate that the C terminus of the protein is involved in the binding of Gαq. Moreover, the menthol-induced and TRPM8-mediated activation of a heterotrimeric G protein was established by FRET experiments monitoring the dissociation of Gαq-YFP from a Gβ/γ-CFP complex. G protein activation by menthol was also shown by the exchange of radioactive [³⁵S]GTPγS for GDP in membrane preparations of cells heterologously expressing TRPM8. In another approach using native cells, we performed experiments in adenovirus-transduced trigeminal ganglion neurons, also demonstrating a menthol-mediated stimulation of a metabotropic pathway in these cells. Our findings show that a member of the TRP ion channel family, TRPM8, is not only an ion channel and target of metabotropic signalling, but might directly and functionally interact with Gα subunits to interfere with downstream metabotropic pathways. The observations lead to a view that extends the operational range of the TRPM8 receptor from its function as a pure ion channel to a molecular switch with additional metabotropic capacity, contributing to an extended understanding of the complex mechanisms of signal transduction in sensory systems.

Novel splice variant of calmodulin inhibits human $\text{Ca}_v2.3$ E-/R-type voltage-gated Ca^{2+} channels in HEK-293 cells

Toni Schneider, Marcel A. Kamp², Behzad Shakeri³, Juergen Hescheler¹, Lucie Parent³

¹University of Cologne, Institute for Neurophysiology, Robert-Koch-Str. 39, 50931 Köln, Germany.

²Department of Neurosurgery, University Hospital, Heinrich-Heine-University, Moorenstraße 5, D-40225 Düsseldorf, Germany.

³Department of Physiology, Groupe d'étude des protéines membranaires, Université de Montréal, P.O. Box 6128, Downtown Station, QC, H3C 3J7, Canada.

After activation of metabotropic acetylcholine and glutamate receptors pharmacoresistant voltage-gated calcium channels containing $\text{Ca}_v2.3$ as ion conducting pore affect excitability of hippocampal CA1 pyramidal neurons. Their expression remote from the fast release sites leads to the accumulation of presynaptic Ca^{2+} which can both, facilitate and inhibit the influx of Ca^{2+} ions through $\text{Ca}_v2.3$. The facilitated Ca^{2+} influx was recently related to hippocampal postsynaptic facilitation and long term potentiation. To analyse Ca^{2+} mediated modulation of cellular processes more in detail, protein partners of the carboxy terminal tail of $\text{Ca}_v2.3$ were identified by yeast-2-hybrid screening, leading in two human cell lines to the detection of a novel, extended and rarely occurring splice variant of calmodulin-2 (CaM-2), called CaM-2-extended (CaM-2-ext). CaM-2-ext interacts biochemically with the C-terminus of $\text{Ca}_v2.3$ similar to the classical CaM-2 as shown by co-immunoprecipitation. Functionally, only CaM-2-ext reduces whole cell inward currents significantly. The insertion of the novel 46 nts long exon and the consecutive expression of CaM-2-ext must be dependent upon a new upstream translation initiation site which is only rarely used in the tested human cell lines. The structure of the N-terminal extension is predicted to be more hydrophobic than the remaining CaM-2-ext protein, suggesting that it may help to dock it to the lipophilic membrane surroundings.

DISSECTING THE ACTIVATION OF AMPA RECEPTORS

Andrew John Plested, Miriam Chebli¹, Hector Salazar¹, Valentina Ghisi¹, Jelena Baranovic¹, Kajta Faelber², Oliver Daumke²

¹FMP Berlin, Molecular Neuroscience and Biophysics, Robert-Roessle-Str 10, 13125 Berlin, Germany

²MDC Berlin, Robert-Roessle-Str 10, 13125 Berlin, Germany

Ionotropic glutamate receptors are tetrameric ion channels that are activated by the neurotransmitter glutamate at excitatory synapses. It is known that after the binding of glutamate, the AMPA-subtype of glutamate receptors transits through distinct functional states to become fully activated, however, the conformations sampled by the tetramer during activation remain unknown. We have subjected plausible models of the tetramer of ligand binding domains to a panel of trapping bridges combined with electrophysiology, biochemistry and crystallography. These experiments were designed to probe the geometry of the different states sampled by the ligand binding domains during receptor activation. We show that the mutant A665C is preferentially crosslinked in the presence of the partial agonist, kainate. In addition, the same crosslink trapped a much more stable conformation in the desensitized state. We also resolved fast disulfide trapping on the millisecond time scale in the resting state of the glutamate receptor, providing insight into dynamics of the receptor complex at rest. Finally, we present engineered metal trapping bridges that trap conformations distinct from those observed in the full-length resting state crystal structure (Sobolevsky et al, 2009 Nature). Overall, our results reinforce the idea that the ligand binding domains are highly flexible and sample a surprisingly large conformational space.

Rab8a mediates acidosis-induced trafficking of NBCe1-A in hippocampal neurons

Eleni Roussa, Jan Manuel Speer¹, Oliver Oehlke¹

¹University of Freiburg, Anatomy and Cell Biology; Molecular Embryology, Albertstr. 17, 79104 Freiburg, Germany

The electrogenic sodium-bicarbonate-cotransporter (NBCe1) is a key player in regulation of intracellular pH in several cell types. In the CNS however, modes of intracellular pH regulation reveal considerable differences, compared to other tissues, because both neuronal activity and several pathological conditions are accompanied by pH shifts. We have previously shown expression of the NH₂-terminal variant NBCe1-A in neurons of hippocampus, cerebral cortex, olfactory bulb and cerebellum. However regulation of NBCe1-A during changes of extracellular pH has not been addressed so far.

In the present study we have investigated regulation of NBCe1-A in neurons after changes of extracellular pH in vitro, using mouse hippocampal primary cultures as model.

The results show that extracellular acidosis or alkalosis had no impact on transcript expression and protein expression of NBCe1-A in mouse hippocampal neurons in vitro, as determined by quantitative real-time PCR and western blot, respectively. However, acute extracellular acidosis caused NBCe1-A redistribution from the cytosol and increased membrane expression of NBCe1-A. Quantification of NBCe1-A translocation following extracellular acidosis has been performed by determination of co-localization between NBCe1-A and the Golgi marker Golgi58K using the Pearson's correlation coefficient. Challenging the cells with acidotic culture medium significantly decreased Pearson's correlation coefficient for NBCe1-A and Golgi58k, compared to the controls. Moreover, biotinylation of surface proteins showed increased surface expression of NBCe1-A during acidosis, compared to the untreated controls. The results also show that NBCe1-A co-localizes and interacts with Rab8a in hippocampal neurons in vitro and in vivo. In addition, acidosis-induced NBCe1-A redistribution in neurons is mediated by Rab8a. Transient knock down of Rab8a with specific Rab8a siRNA prevented acidosis-induced NBCe1-A translocation to the membrane in mouse hippocampal neurons in vitro.

The results suggest redistribution of acid-base transporters as potent regulatory mechanism during changes of extracellular pH. Moreover, NBCe1-A may be involved in neuronal modulation and intracellular pH regulation.

Regulation of acid-base transporters in epilepsy

Magdalena Schroedl, Oliver Oehlke¹, Jan Manuel Speer¹, Eleni Roussa¹

¹University of Freiburg, Anatomy and Cell Biology; Molecular Embryology, Albertstr. 17, 79104 Freiburg, Germany

Changes of extracellular pH (pH_o) are events associated with both physiological conditions and pathological states in brain function. Physiological processes in the brain are however mostly associated by transient pH_o changes, while loss of pH homeostasis can lead to severe pathological conditions. Moreover, significant changes of pH_o have also been observed during seizures and spreading depression. Whether extracellular pH changes can influence intracellular pH depends on the effectiveness of the mechanisms of intracellular pH regulation, among them the membrane transport of acid-base equivalents. Vice versa, acid-base transporters may affect neuronal excitability and synaptic transmission by regulating the local pH in the brain. However, regulation of neuronal acid-base transporters during pH shifts under physiological and pathological conditions is far from being understood.

In the present study, we sought to investigate regulation mechanisms of the NH₂-variants of the electrogenic sodium/bicarbonate cotransporter 1, NBCe1 -A and NBCe1 -B and of the vacuolar H⁺-ATPase (V-ATPase) in hippocampal neurons following kainic acid-induced status epilepticus in vivo and using the 4-aminopyridine (4-AP) model of epilepsy in vitro.

We show activity-dependent differential regulation of acid-base transporters in the hippocampus during seizures, determined by quantitative real-time PCR and western blot. Moreover, immunofluorescence showed increased membrane expression of NBCe1-A in CA1 and CA3 region, but not in the granule cells of the dentate gyrus of the hippocampus during seizures. The results also show that activity-dependent upregulation and membrane expression of NBCe1-A was dependent on Src/ERK signaling. Either inhibition of Src with PP2 or ERK with U0126 prevented seizures-induced NBCe1-A upregulation and trafficking to the membrane.

These data propose transcriptional and post-translational modification of acid-base transporters as putative regulatory mechanisms in neurons to cope with changes of pH and provide first evidence for a molecular mechanism that could also account for post seizure maintenance of pH homeostasis.

Lysophosphatidic acid activates spinal nerve TRESK background potassium channels

Sina Kollert, Frank Döring¹, Erhard Wischmeyer¹

¹Universität Würzburg, Physiologisches Institut, AG Molekulare Elektrophysiologie, Röntgenring 9, 97070 Würzburg, Germany

Lysophosphatidic acid (LPA) is a small, ubiquitous phospholipid that acts as an extracellular molecule by binding to and activating at least five known G protein-coupled receptors (LPA₁-LPA₅). These receptors are coupled to different signaling pathways that, among others, include trimeric G-proteins of the Ga_{q/11}-type. The biological roles of LPA are diverse and affect developmental, physiological and pathophysiological processes. In the nervous system LPA signaling influences cortical development, survival, migration and proliferation of cells as well as neurological disorders such as schizophrenia and neuropathic pain (Choi et al., 2010). During tissue injury LPA is released from activated platelets or microglia, thereby altering the activity of ion channels that regulate the excitability of neurons.

In a previous study we demonstrated that the tandem-pore potassium channel TRESK constitutes a substantial current component in dorsal root ganglion (DRG) neurons (Dobler et al., 2008). TRESK channels were found to be activated by Ga_{q/11}-coupled receptors in a Ca²⁺-dependent manner, which involves binding and activation of calcium-calmodulin-dependent phosphatase 2B (Calcineurin; Czirják et al., 2004). Here, we investigate the regulation of TRESK channels by LPA and its G-protein coupled receptors.

After molecular cloning in vitro transcripts of LPA₂ receptors were coexpressed with mouse TRESK channels in *Xenopus* oocytes. Under control condition two electrode voltage clamp recordings display robust outwardly rectifying potassium currents (1.83µA at +30mV), which were increased by almost 8-fold upon application of 0.5µM LPA (14.05µA at +30mV, n=8). As *Xenopus* oocytes endogenously express LPA receptors, heterologous expression of TRESK channels alone allows to investigate their regulation by LPA. Augmentation of TRESK currents under these conditions was slightly lower but with a 5-fold increase still very prominent (control: 2µA at +30mV; after application of 0.5µM LPA: 11.4µA at +30mV; n=11). Increasing the extracellular LPA-concentration in the range from 0.05 to 2µM proportionally increased TRESK current with an EC₅₀ of 0.204µM. Because LPA₂ receptors were found to couple to Ga_{q/11}-type proteins we used an inhibitor of phospholipase C (PLC) to block this signaling pathway. Preincubation of oocytes (20 min.) in a bath solution containing the selective PLC inhibitor U73122 (10µM) totally abolished the potentiation of TRESK currents by application of 0.2 or 2 µM LPA, respectively.

In a former study we found TRESK transcripts to be expressed in DRG neurons together with TRPV channels known as a marker for nociceptive cells. Moreover, depolarising TRPV currents strongly increase after direct channel interaction with LPA. As TRESK currents are also augmented by LPA receptor signaling, we suggest that simultaneous activation of both ionic conductances might constitute a novel mechanism to protect nociceptive neurons from overexcitation by painful stimuli.

References:

- Choi et al., 2010, Annu. Rev Pharmacol. Toxicol. 50, pp187-86.
- Czirják et al., 2004, J. Biol. Chem. , 279, pp18550-18558.
- Dobler et al., 2007, J. Physiol. (Lond), 585.3, pp 867-879.

Poster Topic

T7: Synaptic Transmission, Pre- and Postsynaptic organization

- T7-1A** Amyloid precursor proteins are constituents of the presynaptic active zone derived from murine brain
Melanie Laßek, Jens Weingarten, Ilaria Lunger, Teresa Schubach, Kristine Gampe, Ulrike Müller, Walter Volkandt
- T7-2A** The proteome of the presynaptic active zone derived from mouse brain
Jens Weingarten, Melanie Laßek, Benjamin Müller, Ilaria Lunger, Simone Dudek, Patrick Vancura, Michael Karas, Walter Volkandt
- T7-3A** Development of tools for real-time simultaneous visualization of ECM, glial, pre- and postsynaptic structures
Mikhail Filippov, Svetlana Korotchenko, Alexander Dityatev
- T7-4A** The novel TrkB receptor agonist 7,8-Dihydroxyflavone (7,8-DHF) inhibits GABAergic neurotransmission and increases intrinsic excitability in pyramidal neurons of mouse visual cortex
Daniele Marongiu, Barbara Imbrosci, Thomas Mittmann
- T7-5A** NMDA receptor dependence of complex spike bursts in CA1 hippocampal neurons in vivo
Christine Grienberger, Xiaowei Chen, Arthur Konnerth
- T7-6A** Generation of a First Comprehensive Protein Interaction Map for the Chemical Synapse
Philipp Trepte, Angeli Möller, Martin Schäfer, Miguel Andrade, Erich E Wanker
- T7-7A** Structure-function analysis of the vesicular glutamate transporter 1 C-terminus
Julia Jordan, Melissa Herman, Thorsten Trimbuch, Christian Rosenmund
- T7-8A** Heterogeneous effects of adenosine on layer 4 synaptic transmission in rat barrel cortex
Guanxiao Qi, Karlijn van Aerde, Dirk Feldmeyer
- T7-9A** Mechanisms of kHz-transmission at a central synapse
Andreas Ritzau-Jost, Annika Weyhersmüller, Igor Delvendahl, Johannes Hirrlinger, Hartmut Schmidt, Jens Eilers, Stefan Hallermann
- T7-10A** Protein distributions underlying differential dendritic calcium signaling in cerebellar Purkinje cells
Christian D Wilms, Tiago Branco, Kristina D Micheva, Stephen J Smith, Michael Häusser

- T7-11A** Isolation and characterization of new active zone proteins
Christina Hollmann, Harald Depner, Christine Quentin, Henning Urlaub, Matthew Holt, Stephan Sigrist
- T7-1B** Dynamin 1-dependent endocytosis at the inner hair cell synapse
Jakob Neef, Sangyong Jung, Christine Lenz, Rebecca M Boumil, Wayne N Frankel, Pietro De Camilli, Nicola Strenzke, Tobias Moser
- T7-2B** The Role of PSD-95 and Kinase Interactions in Synaptic Function
Seniye Derya Akad, Oliver M. Schlüter
- T7-3B** The role of complexin I in synaptic transmission and short-term plasticity at the calyx of Held synapse
Shuwen Chang, Meike Pedersen, Kerstin Reim, Holger Taschenberger
- T7-4B** Activity of NPS-neurons is modulated by dynorphin A – Indications for a central amygdalar negative feedback
Kay Jüngling, Hanna Szkudlarek, Frank Erdmann, Hans-Christian Pape
- T7-5B** microRNA137 regulates the expression of synaptic proteins and is involved in synaptic plasticity and learning and memory
Sandra Siegert, Ester J Kwon, Andrii Rudenko, Jinsoo Seo, Sukhee Cho, Wenyuan Wang, Zachary Flood, Li-Huei Tsai
- T7-6B** From Pattern Generator to Sound Receptor, Hair Cells Adjust Ca²⁺ Signaling to Their Function during Development
Aaron Benson Wong, Mark Allen Rutherford, Zhizi Jing, Thomas Frank, Tina Pangrsic, Nicola Strenzke, Carolin Wichmann, Tobias Moser
- T7-7B** Abundance of synapsin proteins regulates the size of synaptic vesicles and active zones
Mariya Vasileva, Robert Renden, Heinz Horstmann, Daniel Gitler, Thomas Kuner
- T7-8B** Neuroplastin-65 regulates structure and maintenance of excitatory synapses and GABAA receptor localization at inhibitory synapses
Rodrigo Herrera-Molina, Martin Heine, Karl-Heinz Smalla, Constanze I. Seidenbecher, Eckart D. Gundelfinger, Dirk Montag
- T7-9B** Membrane targeting of collybistin is required for gephyrin clustering at inhibitory postsynapses
Simone Mayer, Tolga Soykan, Nils Brose, Heinrich Betz, Theofilos Papadopoulos
- T7-10B** The role of Neurobeachin and SAP102 Interaction in the synapse
Fatima Farzana, Juliane Lauks, Ruud Toonen, Matthijs Verhage
- T7-11B** THE CHOLINERGIC MODULATION OF LAYER 6A PYRAMIDAL CELL IN THE SOMATOSENSORY 'BARREL' CORTEX DEPENDS ON THEIR AXONAL PROJECTION PATTERN
Robert Heinz Günter, Gabriele Radnikow, Dirk Feldmeyer
- T7-1C** Molecular regulation of Ca²⁺-dependent neurotrophin secretion in hippocampal neurons by

CAPS1

Robert Eckenstaler, Thomas Munsch, Tanja Brigadski, Volkmar Leßmann

- T7-2C** Mechanisms underlying heterogeneity of Ca²⁺ signaling among hair cell active zones
Tzu-Lun Wang, Mark.A. Rutherford, Tobias Moser
- T7-3C** Extra Cellular Matrix differently affects mobility of AMPA receptors in spiny and aspiny synapses
Yulia Klyueva, Renato Frischknecht, Martin Heine
- T7-4C** Gene expression profiling of globular bushy cells during synaptic maturation
Christoph Körber, Anna Dondzillo, Gisela Eisenhardt, Oliver Wafzig, Thomas Kuner
- T7-5C** Functional and dynamic properties of dendritic versus perisomatic inhibition in hippocampal neuronal networks
Shakuntala Savanthrapadian, Imre Vida, Marlene Bartos
- T7-6C** Regulation of presynaptic Ca²⁺ influx during trains of action potential-like stimuli
Kun-Han Lin, Holger Taschenberger
- T7-7C** Characterisation of the transport of Active Zone proteins to Synapses
Tina Ghelani, Thomas Dresbach, Nina Wittenmayer
- T7-8C** Super resolution imaging of brain -derived neurotrophic factor in synapses of hippocampal neurons *in vitro*
Robert Blum, Thomas Andreska, Sarah Aufmkolk, Sebastian van de Linde, Markus Sauer
- T7-9C** Analysis of compartment-specific and cell autonomous loss-of-function of MeCP2
Avani Shukla, Oliver Schlüter
- T7-10C** Dendritic origin of axons in CA1 pyramidal neurons
Christian Thome, Tony Kelly, Maren Engelhardt, Martin Both, Sidney Cambridge, Andreas Draguhn, Heinz Beck, Christian Schultz, Alexei V. Egorov
- T7-11C** Compartmentalization and single cell anatomy of a larval peptidergic circuit in *Drosophila melanogaster*
Gergely Karsai, Christian Wegener, Gergely Berta, László Molnár, Edit Pollák
- T7-1D** A new vertebrate-specific presynaptic protein as molecular component of the endbulb of Held
Friederike Wetzel, Thomas Dresbach
- T7-2D** CHARACTERIZATION OF THE FUNCTIONAL DOMAINS OF A NOVEL PRESYNAPTIC PROTEIN:MOVER
Asha Kiran Akula, Saheeb Ahmed, Camin Dean, Thomas Dresbach
- T7-3D** Changes in the synchrony of cross-synaptic output of a retinal neuron
William N Grimes, Fred Rieke

- T7-4D** Novel genetic mouse model for Bassoon and Piccolo allowing functional studies in developing and adult brain
Sabrina Müller, Anil Annamneedi, Anna Fejtová, Eckart D. Gundelfinger
- T7-5D** Presynaptic targeting of Mover involves a self-interaction domain
Thomas Dresbach, Asha Kiran Akula, Nina Wittenmayer, Jan Höber
- T7-6D** GABA related proteins persist beyond the developmental GABA to glycine shift at inhibitory auditory brainstem synapses of mice
Alexander Fischer, Jennifer Smuda, Matthew A. Xu-Friedman, Eckhard Friauf, Désirée Griesemer
- T7-7D** Mechanisms of neurotransmitter release at the inner hair cell ribbon synapses
Nikolai M. Chapochnikov, Hideki Takago, Elisabeth Auge, Caroline Wichmann, Tobias Moser, Fred Wolf
- T7-8D** Analysis of the balanced state in a 2-population network by mean-field theory
Alexander Schmidt, Fred Wolf, Michael Monteforte
- T7-9D** Properties of Synaptic Transmission at a Corticothalamic Giant Synapse in Mice
Francisco José Urra Quiroz, Thomas Kuner
- T7-10D** Functional changes of presynaptic Active Zone induced by endogenous Amyloid beta
Maria Andres-Alonso, Vesna Lazarevic, Eckart Gundelfinger, Anna Fejtova
- T7-11D** C-terminal Binding Protein 1: a novel neuronal metabolic sensor involved in the activity-dependent gene expression
Anika Dirks, Daniela Ivanova, Cornelia Schoene, Denny Schanze, Anna Fejtova, Eckart D. Gundelfinger

Amyloid precursor proteins are constituents of the presynaptic active zone derived from murine brain

Melanie Laßek, Jens Weingarten¹, Ilaria Lunger¹, Teresa Schubach¹, Kristine Gampe¹,
Ulrike Müller², Walter Volkandt¹

¹Institute for Cell Biology and Neuroscience, Biologicum, Goethe University, Frankfurt am Main, Germany

²Department of Pharmacy and Molecular Biotechnology, University Heidelberg, Germany

The hallmarks of Alzheimer's disease, like synaptic dysfunction and cognitive decline are associated with amyloid β plaques derived from the amyloid precursor protein (APP). Since APP has been cloned in the 1980s extensive research has been performed to unravel the physiological functions of APP and its mammalian homologues the amyloid precursor like protein 1 (APLP1) and amyloid precursor like protein 2 (APLP2).

All proteins of the amyloid precursor protein family are type 1 transmembrane proteins characterized by a large extracellular ectodomain, one transmembrane domain and a short cytoplasmatic tail. Enzymatic cleavage by α -, β - and γ -secretase leads to similar proteolytic fragments although the A β sequence is absent in APLP1 and APLP2. Regarding the mRNA expression in developing and adult mouse tissue APP and APLP2 are ubiquitously expressed while the APLP1 mRNA is restricted to the CNS. Employing subcellular fractionation of synaptosomes derived from murine brain and making use of a monoclonal antibody directed against the integral synaptic vesicle protein SV2, we recently immunopurified synaptic vesicles being docked to the presynaptic active zone. The immunisolated fractions were analyzed by electron microscopy and individual protein bands were separated by SDS-PAGE, dSDS-PAGE and DIGE and further subjected to mass spectrometry or Western blotting.

Upon subcellular fractionation of synaptosomes derived from rat and mouse brain, the APP family members were detected in the denser fractions of the sucrose gradient revealing an overlap with the migration pattern of presynaptic plasmamembrane constituents. Subsequent immunoisolation of fractions containing either free synaptic vesicles or fractions containing synaptic vesicles docked to the presynaptic active zone exhibited that APP and its family members are present in the presynaptic active zone fractions. Our results clearly demonstrate that APP and the APLPs are constituents of the presynaptic active zone derived from murine brain and enable a further proteomic analysis of APP/APLP mutant mice compared to control mice.

The proteome of the presynaptic active zone derived from mouse brain

Jens Weingarten, Melanie Laßek¹, Benjamin Müller², Ilaria Lunger¹, Simone Dudek¹,
Patrick Vancura¹, Michael Karas², Walter Volkandt¹

¹Institute for Cell Biology and Neuroscience, Biologicum, Goethe University, Frankfurt am Main, Germany

²Pharmaceutical Chemistry, Biocenter, Goethe University, Frankfurt am Main, Germany

The proteome of the presynaptic active zone regulates neurotransmitter release as well as structural and functional dynamics of the nerve terminal. This highly complex and dynamic compartment provides a challenge to identify the proteinaceous inventory to pinpoint important protein candidates for further studies. The refinement and downscaling of the experimental approaches for the preparation and purification of the presynaptic active zone from distinct brain areas like the olfactory bulb, cerebellum and hippocampus will extend new experimental investigations.

In our group the analysis of a presynaptic subproteome is based on subcellular fractionation and immunopurification using a monoclonal antibody directed against the ubiquitous synaptic vesicle protein SV2. Employing different gel based or non-gel based separation techniques with mass spectrometric analysis e. g. nanoLC ESI and MALDI-TOF allows the identification of the proteinaceous constituents making synaptic vesicles the best characterized organelles. In previous studies we purified and characterized the proteome of the presynaptic active zone derived from rats using docked synaptic vesicles as targets for immunoisolation. Comparing the proteome of the presynaptic active zone from rat and mouse we observed a high overlap in the proteinaceous composition. Interestingly, the immunoisolated active zone derived from mouse brain contains attached patches of the postsynaptic density. Unraveling the complex protein network of the active zone will provide the basis for a better understanding of the underlying mechanisms regulating the assembly of this subproteome and its structural and functional plasticity in adult mouse brain.

Development of tools for real-time simultaneous visualization of ECM, glial, pre- and postsynaptic structures

Mikhail Filippov, Svetlana Korotchenko^{1,3}, Alexander Dityatev^{1,4}

¹Laboratory of Brain ECM Research, University of Nizhny Novgorod, Russia, 70 Prospekt Gagarina, 603059 Nizhni Novgorod, Russia

²Cellular Neurophysiology, Medical School Hannover, Hannover, Germany

³Department of Neuroscience and Brain Technologies, Istituto Italiano di Tecnologia, Genova, Italy

⁴Molecular Neuroplasticity Group, DZNE, Universitätsklinikum Magdeburg, Germany

Recent studies point to the extracellular matrix (ECM) as important player in the synaptic signaling. Understanding the interactions between ECM and other synaptic components - presynaptic, postsynaptic, and glial - may challenge our current view of synaptic plasticity and homeostatic regulations in health and disease. We have developed a system of viral vectors, which allows us to follow up the dynamics of components of the tetrapartite synapse (Dityatev and Rusakov, *Curr Opin Neurobiol* 2011; 21:353-9) in living neural cells. This is achieved by expression of fluorescent proteins that are used to tag proteins specific for the presynapse (synaptophysin), postsynapse (GluA or fEGFP) or ECM (brevican or LGI1). We used the viruses carrying the minimal promoter of synapsin I and engineered GFAP (GfaABC1D). We demonstrate here that using the following fluorescent tags - TagBFP, EGFP, TagRFP and TurboFP650 - we can simultaneously visualize the perineuronal nets, postsynaptic content, presynaptic boutons and astroglia, respectively, without overlapping of emission spectra and other technical restrictions. We can monitor these markers for a long time in living synapses in vitro. The turnover of perineuronal nets in vitro could be additionally assessed using a *Vicia villosa* lectin repetitive labeling. In summary, the system opens new possibilities to monitor the synaptogenesis and synaptic plasticity in physiological and pathological conditions, e.g., in response to epileptogenic stimulation. Supported by IIT and the RF government grant No. 11.G34.31.0012.

The novel TrkB receptor agonist 7,8-Dihydroxyflavone (7,8-DHF) inhibits GABAergic neurotransmission and increases intrinsic excitability in pyramidal neurons of mouse visual cortex

Daniele Marongiu, Barbara Imbrosci¹, Thomas Mittmann¹

¹Johannes Gutenberg-Universität, Institut für Physiologie und Pathophysiologie, Duesbergweg 6, 55128 Mainz, Germany

The neurotrophin Brain-Derived-Neurotrophic-Factor (BDNF) exerts a pleiotropic effect on synaptic transmission in different brain regions through the activation of TrkB receptors. Interestingly, alterations in the BDNF-TrkB signalling pathway have been reported in several psychiatric and neurodegenerative diseases such as Parkinson's disease, Alzheimer's disease, schizophrenia and depression. Therefore, this pathway represents a key target in the treatment of these disorders. Clinical trials using recombinant BDNF have been disappointingly negative presumably because of the poor pharmacokinetic profile of BDNF, that limits its therapeutic potential. Although many efforts have been made to circumvent this problem, no exogenous agents have been identified that act as potent and selective *in vivo* agonists of TrkB receptors. Recently, Jang et al (2010) screened a library of new chemical compounds and isolated a small molecule, 7,8-Dihydroxyflavone (7,8-DHF), which possesses a potent neurotrophic activity. It belongs to the Flavonoids family, natural compounds present in fruits and vegetables with different biological properties ranging from antioxidant and anti-inflammatory to anxiolytic and antidepressive. Due to their lipophilic structure they can pass the blood-brain-barrier and act directly on the central nervous system. The existing literature shows that 7,8-DHF shares many of these properties. *In vitro*, 7,8-DHF binds TrkB receptors with high affinity and provokes its dimerization and autophosphorylation, leading to the activation of the downstream intracellular signalling cascades. When administered systemically *in vivo*, 7,8-DHF causes a substantial activation of TrkB receptors in the whole brain. Furthermore like BDNF, this substance has been shown to be neuroprotective against excitotoxic and ischemic damage, to influence the emotional behaviour as well as to rescue memory and cognitive deficits in aged animals. Despite all these findings its precise mechanism of action at the cellular level has not been yet clarified. In the present study we investigated the effects of this agent on synaptic and intrinsic neuronal properties by performing whole cell patch clamp recordings from layer 2/3 pyramidal neurons in mouse visual cortex. Incubation of acute cortical slices with 7,8-DHF (20 μ M) for 30 minutes caused a selective reduction in the strength of GABAergic inhibition, which is most likely due to a decrease in presynaptic GABA release, as suggested by the observed reduced mIPSCs frequency and increase in the PPR of eIPSCs. Surprisingly, the glutamatergic transmission was unaffected. Moreover, 7,8-DHF was able to alter the intrinsic excitability of neurons. 7,8-DHF treated neurons exhibited a higher spike frequency, most likely caused by an increased input resistance. Remarkably, all the reported effects were abolished in presence of K252a (a TrkB receptor antagonist) indicating a direct involvement of TrkB receptors in the action of 7,8-DHF. Our findings could contribute in paving the way for the development of a new class of drug "BDNF mimetics", which can be used as a tool for the treatment of cognitive disorders and neurodegenerative diseases.

NMDA receptor dependence of complex spike bursts in CA1 hippocampal neurons in vivo

Christine Grienberger, Xiaowei Chen¹, Arthur Konnerth¹

¹Technical University Munich, Institute of Neuroscience, Biedersteiner Str. 29, 80802 Munich, Germany

Complex spike bursts are an essential feature of hippocampal CA1 pyramidal cell activity. They were observed in vivo for a long time in rodents and cats (e.g. Kandel and Spencer, 1961; Ranck, 1973; Harris, Hirase, Leinekugel, Henze, Buzsaki, 2001). Recently, their functional relevance for the formation and stabilization of spatial maps has been established (Epszstein, Brecht, Lee, 2011). On the circuit level, burst firing has a strong impact on downstream neurons and may be critically involved in the induction of synaptic plasticity (Sjöström and Nelson, 2002). In vitro studies have highlighted the role of voltage-gated conductances in burst firing of CA1 hippocampal neurons, particularly TTX-sensitive sodium conductances (Azouz, Jensen, Yaari, 1996; Golomb, Yue, Yaari, 2006). In addition, there is evidence that the coincidence of back-propagating action potentials with strong and synchronous synaptic inputs can produce plateau potentials which may underly burst firing (Takahashi and Magee, 2009). However, the mechanisms underlying complex spike bursts in vivo remained unknown.

Here, we used in vivo two-photon microscopy to perform targeted whole-cell recordings and imaging of calcium signals in dorsal hippocampal CA1 pyramidal cells in head-fixed anesthetized mice. In these mice, the hippocampus had been made accessible for imaging experiments by removing a small portion of the covering cortical tissue. We found that all neurons recorded (30/30) were endowed with the capability of exhibiting complex spike bursts. These consisted of high-frequency spikes riding on an underlying large depolarizing wave (groups of about 4-8 spikes at 200-300 Hz and depolarizing wave of about 30 mV). Importantly, bursting was linearly dependent on the membrane potential. While above about -50 mV all neurons exhibited reliably bursts, below -65 mV bursting was completely abolished. When neurons were depolarized by current injection to levels above -40 mV, spike firing disappeared due to the inactivation of voltage-gated sodium channels. Nevertheless, depolarizing waves, indistinguishable to those associated with complex burst firing, persisted. Furthermore, similar depolarizing waves were observed also in the presence of the antagonist of sodium channels QX-314 inside the neurons. Finally, complex spike bursts were completely abolished in neurons that were dialyzed with the NMDA receptor antagonist MK-801. Thus, our results firmly establish the synaptic origin of complex spike bursts and the requirement for NMDA-R activation in vivo.

Generation of a First Comprehensive Protein Interaction Map for the Chemical Synapse

Philipp Trepte, Angeli Möller¹, Martin Schäfer², Miguel Andrade², Erich E Wanker¹

¹Proteomics and Molecular Mechanisms of Neurodegenerative Diseases, Max Delbrück Center for Molecular Medicine, Robert-Rössle-Str. 10, 13125 Berlin, Germany

²Computational Biology and Data Mining, Max Delbrück Center for Molecular Medicine, Robert-Rössle-Str. 10, 13125 Berlin, Germany

Synapses are highly structured compartments that enable information processing and transfer between neurons. Recent proteomic studies have dramatically increased our knowledge of the protein-composition of the synapse. Correct synaptic function relies on protein-protein interactions (PPIs) and the assembly of multiprotein complexes. Synaptic dysfunctions can lead to severe neurological disorders like schizophrenia, epilepsy or neurodegenerative diseases that might arise in part from abnormal PPIs. Large-scale human PPI maps have already been created previously for several signaling pathways, human diseases and whole organisms.

Analyzing interactions specifically between synaptic proteins will not only give new insights in key synaptic processes but also sheds light on disease mechanisms and molecular dysfunctions occurring at the synapse. Therefore, we combined the classical yeast-two hybrid method with a recently developed split-ubiquitin system to identify over 3,000 high-confidence PPIs connecting 705 synaptic proteins. This approach allowed the generation of a large, highly connected interaction network for the chemical synapse. Furthermore, we validated 451 out of 756 tested high-confidence PPIs (~60%) using a mammalian cell -based co -immunoprecipitation assay. Network analyses will be applied to predict proteins involved in key synaptic processes like synaptic vesicle cycling, receptor trafficking or synaptogenesis. Finally, proteins interacting with known disease proteins or proteins participating in disease processes will be defined. We suggest that our network biology strategy will allow the prediction of potential drug targets for the development of novel therapeutic approaches.

Structure-function analysis of the vesicular glutamate transporter 1 C-terminus

Julia Jordan, Melissa Herman², Thorsten Trimbuch³, Christian Rosenmund⁴

¹Charite Berlin, Neurowissenschaftliches Forschungszentrum - AG Rosenmund, Chariteplatz 1, 10117 Berlin, Germany

Vesicular glutamate transporters (Vgluts) are essential for filling synaptic vesicles with glutamate at presynaptic nerve terminals of excitatory neurons. Recent studies could also show an additional role of Vgluts in regulating synaptic efficacy in mice (Weston et al., 2011), but the underlying mechanism are not completely solved.

Mammalian Vglut isoforms show close similarities related to substrate specificity and kinetics. According to their amino acid sequences, the membrane-spanning segments are nearly identical, but the N- and C-terminal tails, which face the cytoplasm, have little homology. From other vesicular neurotransmitter transporter we know that C-terminal structures such as internalization motifs and phosphorylation sites are involved in transporter activity and trafficking. For VGLUTs a dileucine-like motif (FV) has been identified and shown to be critical for the transporter trafficking (Voglmaier et al., 2006), but little is known if differences in trafficking might influence the release probability of neurotransmitter release. Also multiple phosphorylation-sites are predicted for the Vglut C-terminus.

To find out whether phosphorylation is required for Vglut recycling and if transporter trafficking might regulate release probability we started to do structure-function studies of the Vglut 1 C-terminus using whole-cell patch clamp electrophysiology and pHlourin imaging in hippocampal autaptic culture.

Heterogeneous effects of adenosine on layer 4 synaptic transmission in rat barrel cortex

Guanxiao Qi, Karlijn van Aerde¹, Dirk Feldmeyer^{1,2,3}

¹Institute of Neuroscience and Medicine, INM-2, Research Centre Jülich, D-52425 Jülich, Germany

²Department of Psychiatry, Psychotherapy and Psychosomatics, RWTH Aachen University, D-52074 Aachen, Germany

³Jülich-Aachen Research Alliance-Brain, Translational Brain Medicine, D-52074 Aachen, Germany

The neuromodulator adenosine is considered to be a key regulator of sleep homeostasis. Its concentration increases over the course of the day and in particular during sleep deprivation. However, little is known about adenosine effects on synaptic transmission between identified neurons.

In most neocortical layer 4 (L4) spiny neurons adenosine (100 μ M) caused a hyperpolarisation (-6.0 \pm 3.4 mV) while L4 interneurons were nearly unresponsive. Therefore, we studied how this differential modulation affected synaptic transmission in four different types of identified L4 synaptic connections in the primary somatosensory (barrel) cortex of 3 to 4 week old rats using paired recordings and simultaneous biocytin fillings.

Connections between pairs of L4 spiny neurons showed a marked decrease in EPSP amplitude (from 1.38 \pm 1.21 mV to 0.66 \pm 0.70 mV) and decay time constant (from 38.9 \pm 14.3 to 19.5 \pm 7.5 ms) in the presence of 100 μ M adenosine while the coefficient of variation (CV; from 0.33 \pm 0.18 to 0.59 \pm 0.23) and the paired-pulse ratio (PPR; from 0.92 \pm 0.12 to 1.17 \pm 0.37) increased significantly. EPSPs at L4 spiny neuron-L4 interneuron connections also decreased in amplitude (from 2.68 \pm 1.82 mV to 1.11 \pm 0.83 mV) while the decay time constant was not affected (9.5 \pm 1.8 vs. 9.0 \pm 1.6 ms); the CV at this connection increased from 0.27 \pm 0.10 to 0.47 \pm 0.16 and the PPR from 0.95 \pm 0.31 to 1.05 \pm 0.30. In contrast, IPSPs at the L4 interneuron-L4 spiny neuron connection showed only a slight reduction of the IPSP amplitude (from -2.56 \pm 2.38 to -2.43 \pm 2.25) while they decayed markedly faster (34.6 \pm 15.7 vs. 24.7 \pm 7.0 ms). The CV and PPR at this connection were unaffected by adenosine. In addition, the IPSP characteristics at L4 interneuron-L4 interneuron connections remained virtually unaltered.

Adenosine suppressed L4 excitatory transmission in a dose-dependent manner (IC₅₀ ~ 10 μ M). Heterogeneous effects of adenosine were regulated by adenosine A₁ receptors, as they could be blocked by the selective A₁ receptor antagonist CPT (5 μ M). Furthermore, they could also be blocked by caffeine (a non-selective, low affinity blocker for adenosine receptors) but at much higher concentrations (>1 mM).

The data show that adenosine differentially affects inhibitory and excitatory connections by causing an overall shift to a lower excitability. These effects result from a selective decrease of the release probability and the synaptic efficacy of excitatory connections as well as an acceleration of the EPSP and IPSP time course in postsynaptic spiny neurons indicative of a less effective PSP summation. This suggests that sleep need acts at several different levels of the cortical microcircuitry.

Mechanisms of kHz-transmission at a central synapse

Andreas Ritzau-Jost, Annika Weyhersmüller^{1,2}, Igor Delvendahl¹, Johannes Hirrlinger^{2,3}, Hartmut Schmidt², Jens Eilers², Stefan Hallermann^{1,2}

¹European Neuroscience Institute, University Medical Center Goettingen, Grisebachstr. 5, 37077 Goettingen, Germany

²Carl-Ludwig-Institute for Physiology, University of Leipzig, Liebigstr. 27, 04103 Leipzig, Germany

³Department of Neurogenetics, Max-Planck-Institute for Experimental Medicine, Hermann-Rein-Str. 3, 37075 Göttingen, Germany

To maximize the speed of information processing, some synapses can sustain high-frequency transmission. However, the limited number of synapses allowing direct recordings has hampered our understanding of the mechanisms of high-frequency synaptic transmission. Here, we establish two-photon microscopy guided recordings from fluorescence labeled presynaptic cerebellar mossy fiber boutons (cMFBs) paired with recordings from postsynaptic granule cells to analyze high-frequency signaling. Remote stimulation of the mossy fiber axon can elicit action potentials at >1 kHz frequency in cMFBs with mean half-width of $123 \pm 9 \mu\text{s}$ ($n = 11$) and minimal action potential broadening during high-frequency transmission. Paired recordings show that frequencies as high as 1 kHz can be transmitted at these synapses. Furthermore, deconvolution of postsynaptic currents in combination with presynaptic capacitance measurements indicates heterogeneous release probabilities and rapid vesicle reloading kinetics. Finally, elevation of the calcium buffer EGTA to 5 mM in the presynaptic terminal had little effect on the initial fast release component, indicating tight coupling between calcium channels and sensors of exocytosis in a subset of vesicles. These data suggest that a variety of functional specializations permits kHz-transmission at a central synapse.

Protein distributions underlying differential dendritic calcium signaling in cerebellar Purkinje cells

Christian D Wilms, Tiago Branco¹, Kristina D Micheva², Stephen J Smith², Michael Häusser¹

¹Wolfson Institute for Biomedical Research, University College London, Gower Street, WC1E 6BT London, UK

²Dept. of Molecular and Cellular Physiology, Stanford University, Stanford, CA, USA

Cerebellar Purkinje cells (PC) receive on the order of 150,000 glutamatergic parallel fiber (PF) inputs onto their dendrites. Recent *in vivo* experiments have shown that sensory stimulation recruits PFs in bursts of 2 – 5 action potentials, and that recruited PFs are spatially clustered. It is not known how PC dendrites integrate this spatio-temporal activation pattern – both electrically and biochemically.

Here we describe how physiological spatio-temporal PF activation patterns are integrated by PC dendrites. We used patterned two-photon uncaging of MNI-glutamate in cerebellar slices, in combination with somatic whole-cell recording and two-photon calcium imaging. Based on results from *in vivo* measurements of PF and granule cell activity, we stimulated groups of 8 diffraction-limited spots within a radius of 10 μm , delivering two uncaging pulses per spot at 100 Hz. We found calcium transients resulting from activation of both voltage-gated calcium channels ("early") and metabotropic glutamate receptors ("delayed"). Individual branches reproducibly displayed very different combinations of these two components, even when belonging to the same parent dendrite. Surprisingly, dendritic calcium signals were not directly correlated with the corresponding electrical somatic response. Furthermore, the calcium response type did not correlate with morphological parameters (branchlet length, density of the stimulated spines within the branchlet, or distance of the stimulated spine group from the tip or base of the dendrite). These findings suggest that differential expression of voltage-gated channels and proteins involved in mGluR1 signal transduction might underlie the branch-specific calcium signaling we observe. We are probing this potential mechanism by combining functional and immunohistological microscopy: After response properties of dendritic branchlets were determined by glutamate uncaging, the relative density of calcium signaling molecules in these dendrites are assessed using Array Tomography. Initial experiments indicate that at least two involved proteins (mGluR1 and P/Q -type channels) are differentially distributed.

Inter-branch variations in calcium signaling suggest that PC dendritic branches can individually regulate and compartmentalize their integrative properties. Our approach will allow identification of cellular mechanisms responsible for implementing this compartmentalization.

Isolation and characterization of new active zone proteins

Christina Hollmann, Harald Depner^{1,2}, Christine Quentin^{1,2}, Henning Urlaub³, Matthew Holt⁴, Stephan Sigrist^{1,2}

¹Freie Universität Berlin, Takustraße 6, 14195 Berlin, Germany

²CharitéCrossOver, Charitéplatz 1, 10117 Berlin, Germany

³Bioanalytical Mass Spectrometry Group Max-Planck-Institut für biophysikalische Chemie, Am Faßberg 11, 37077 Göttingen

⁴VIB Center for the Biology of Disease, KU Campus Gasthuisberg, Herestraat 49, 3000 Leuven

At the synapse, transmitter release takes place at specialized areas of the cell membrane called active zones (AZ). A complex release machinery is involved in the fusion process of synaptic vesicles (SV). In *Drosophila*, one major component of this machinery is Bruchpilot (BRP) (homologue to ERC/CAST), an elongated protein known to be essential for proper transmitter release. It is a central part of the cytomatrix of the AZ (CAZ) which in electron micrographs is represented by an electron-dense structure called T-Bar. For a better understanding of the molecular composition and function of the CAZ the identification of other key players involved in SV exocytosis is under intense investigation. We addressed this question by isolating subcellular fractions of *Drosophila* head tissue enriched in AZ membranes. Immunoprecipitation of BRP followed by mass-spectrometry based protein identification provided us with a list of novel putative AZ components. We started to analyze 56 candidate genes in an RNAi based loss-of-function assay employing the GAL4/UAS system for nervous system specific expression. Established behavioral assays (survival, larval and adult locomotion) as well as a physiological assay (electroretinography) of high-throughput to probe for defects in synaptic transmission were applied. Structure/morphology of the larval neuromuscular junction (NMJ) and its synapses was examined by fluorescence light microscope (using pre- and postsynaptic markers).

Candidate genes with phenotypic manifestations were selected for electrophysiological recordings of the neuromuscular junction as well as ultrastructural analysis of NMJ synapses by electron microscopy. Finally, as many phenotypes are very subtle and some genes may not give rise to an easily detectable phenotype (e.g. genetic or functional redundancy) we furthermore raised antibodies against selected candidate proteins in order to screen for proteins localizing at the synapse.

Dynamin 1-dependent endocytosis at the inner hair cell synapse

Jakob Neef, Sangyong Jung¹, Christine Lenz¹, Rebecca M Boumil², Wayne N Frankel², Pietro De Camilli³, Nicola Strenzke¹, Tobias Moser¹

¹Inner Ear Lab, University of Goettingen Medical School, Robert-Koch-Str. 40, 37075 Göttingen, Germany

²The Jackson Lab., Bar Harbor, ME

³Department of Cell Biology, Yale University School of Medicine, New Haven, CT

Synaptic vesicle recycling sustains neurotransmission at the ribbon-type active zones of auditory inner hair cells (IHCs), where graded receptor potentials drive vesicle release at rates of hundreds per second over prolonged periods of time. Thus release in hair cell ribbon synapses greatly surpasses the amount of release from most conventional synapses requiring robust mechanisms of membrane retrieval and vesicle replenishment to the active zone. However, little is known on the mode(s) of endocytosis and the underlying molecular mechanisms.

Functionally, evidence has been presented for two kinetic modes of endocytosis in hair cells: rapid (time constant of 0.3 s) and slow (compensatory, time constant of 7-15 s), whereby the slow mode is predominant following Ca²⁺ influx -triggered exocytosis. Rapid hair cell endocytosis required high intracellular Ca²⁺ concentrations usually exceeding 15 μ M.

We have started to characterize the expression of endocytic proteins in mouse inner hair cells, demonstrating the presence of key proteins such as the adaptor proteins, dynamin and clathrin. Moreover, we have observed a hearing impairment in a mouse line carrying a hypomorphic allele of dynamin 1 (fitful). Here, we report an impaired endocytic membrane retrieval in IHCs of fitful mice and knock-out mice lacking dynamin 1. The mutations caused a slowing of compensatory endocytosis following exocytosis of the readily releasable pool in response to brief depolarizations, while endocytosis seemed unaffected following prolonged depolarization. Interestingly, none of the manipulations of endocytosis affected exocytosis even if probed by repetitive stimulation. In conclusion, IHCs require functional dynamin 1 for normal endocytosis following short stimuli but seem to employ an alternative mechanism for retrieval of larger amounts of membrane.

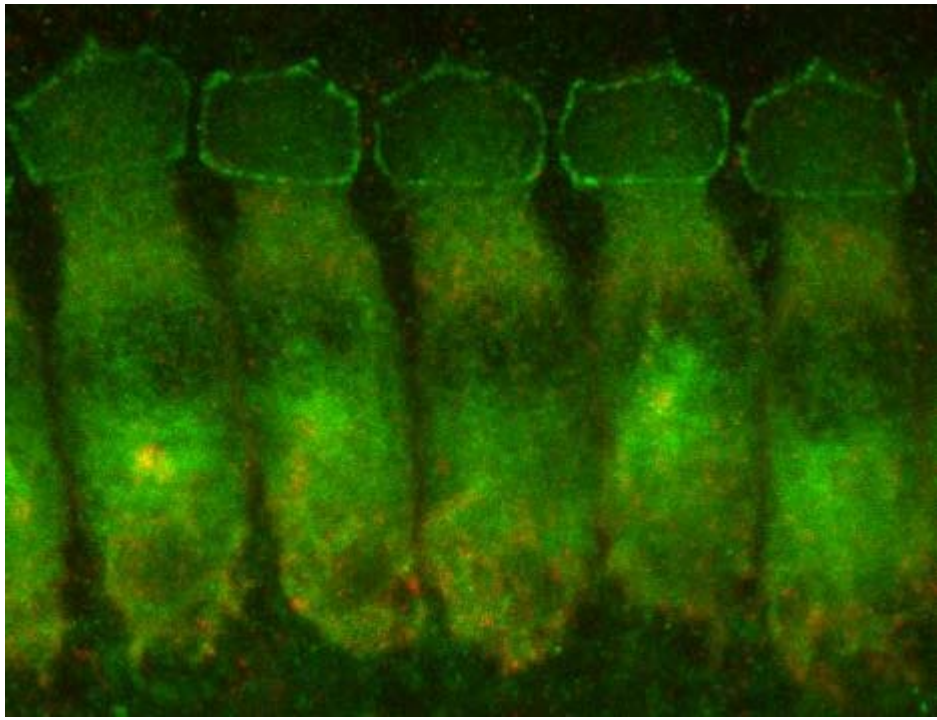

The Role of PSD-95 and Kinase Interactions in Synaptic Function

Seniye Derya Akad, Oliver M. Schlüter^{1,2}

¹European Neuroscience Institute, Molecular Neurobiology, Göttingen, Germany

²International Max-Planck Research School, PhD Neuroscience Program, Göttingen, Germany

Wiring the brain during development to bring it into a mature state involves major changes. One of them is the developmental NMDAR subunit switch observed in both hippocampus and visual cortex (VC). NR2B containing NMDARs predominate at birth, whereas preferentially NR2A containing ones increase steeply after 2-3 weeks of birth. This is prominent in the VC, where the switch coincides with eye opening. Additionally, the levels of PSD-95, a major post-synaptic scaffold increase in parallel. This increase was postulated to be causative, as in PSD-95 KO mice, the NR2B levels remain high. In this project, we focused on the CDK5-PSD95 and Src kinase interaction. CDK5 is known to phosphorylate PSD-95. This phosphorylation mediates PSD-95 interaction with Src kinase which in turn regulates the NR2B containing NMDAR surface expression in hippocampal neurons. Using a lentivirus based molecular replacement technique, we performed biochemical assays as well as electrophysiological recordings on rat hippocampal organotypic slices and acute mouse visual cortex slices. We demonstrated the effect of CDK5 phosphorylation on PSD-95 regarding basal synaptic transmission in hippocampal CA1 pyramidal neurons. A PSD-95 mutant mimicking the phosphorylated state enhanced both AMPAR and NMDAR transmission while another non-phosphorylatable mutant did not alter basal synaptic transmission significantly. By applying specific blockers targeting NR2B subunit and Src kinase, we could show that the enhancement observed in NMDAR transmission is both NR2B and Src kinase dependent. In addition, we investigated the role of PSD-95 in NMDAR subunit composition in VC layer2 pyramidal cells, before (BEO) and after eye opening (AEO). We revealed that PSD-95 KO mice preserve a juvenile state of NMDAR subunit composition even in AEO period. Performing in-vivo molecular replacements, we aim to identify the mechanism, how PSD-95 regulates the NMDAR subunit composition.

The role of complexin I in synaptic transmission and short-term plasticity at the calyx of Held synapse

Shuwen Chang, Meike Pedersen¹, Kerstin Reim², Holger Taschenberger¹

¹Max-Planck Institute for Biophysical Chemistry, Membrane Biophysic, Am Fassberg 11, 37077 Goettingen, Germany²Max-Planck Institute for Experimental Medicine, Hermann-Rein-Str. 3, 37075 Goettingen³GGNB doctoral program "Sensory and Motor Neuroscience" Göttingen, Germany

Complexins are small synaptic proteins which cooperate with the SNARE-complex during synaptic transmission. Different roles of complexins in the regulation of vesicle exocytosis have been proposed. Based on the results of genetic mutation or knock down/out studies, it is generally agreed that complexins are involved in vesicle priming and exocytosis during fast synchronous release and in clamping vesicles to prevent asynchronous release. However, depending on cell type, organism and experimental approach used, complexins appear to either facilitate or inhibit vesicle fusion. Here, we study the function of complexin I at the calyx of Held synapse. By taking advantage of the large size of the calyx terminal, allowing direct patch-clamp recordings, we investigate the consequences of the loss of function of complexin I. We demonstrate a developmentally aggravating phenotype of reduced EPSC amplitudes and enhanced asynchronous release. We provide evidence for a role of CPX I in recruiting Ca²⁺ channels to docked vesicles which may determine their release probability. The enhanced asynchronous release in complexin-deficient mice slowed-down the recovery of synchronous EPSCs after stimulus trains suggesting both, synchronous and asynchronous release events, were fed by a common pool of vesicles.

Activity of NPS-neurons is modulated by dynorphin A – Indications for a central amygdalar negative feedback

Kay Jüngling, Hanna Szkudlarek¹, Frank Erdmann¹, Hans-Christian Pape¹

¹Westfälische Wilhelms-Universität, Institut für Physiologie I, Robert-Koch Str. 27a, 48149 Münster, Germany

The neuropeptide S (NPS) system is involved in a variety of cognitive functions such as fear extinction, memory formation, and stress coping. In mice expression of NPS is limited to two small clusters of neurons in the brain stem while neuropeptide S receptor (NPSR) is expressed in a variety of CNS regions. Previously, we have shown that NPS -neurons at the locus coeruleus are activated by the corticotropin-releasing factor (CRF), a prototypic member of stress -related peptides (Jüngling et al., 2012).

Here we use transgenic NPS-GFP expressing mice to analyze the modulation of NPS-neurons by the endogenous opioid, dynorphin-A (DynA), which has been shown to be involved in e.g. stress and addiction. We provide evidence by electrophysiological recordings that NPS -neurons are 1) hyperpolarized by a direct postsynaptic effect of DynA and 2) that GABAergic input onto NPS-neurons is reduced by a presynaptic action of DynA. Additionally, we used fluorescent dye coupled cholera toxin subunit B (ChTx) for retrograde tracing studies. Local injection of ChTx into clusters of NPS-GFP neurons resulted in retrogradely labeled neurons in the (ipsilateral) lateral nucleus of the central amygdala (CeL), indicating a functional connection between CeL and NPS-neurons. Of the retrogradely labeled CeL -neurons ~60% were positive for prodynorphin, from which DynA is produced by proteolytic cleavage.

These data suggest that prodynorphin positive neurons of the CeL project onto NPS-neurons and might reduce activity of their target neurons by release of DynA, and form a negative feedback loop between amygdala and NPS-neurons.

microRNA137 regulates the expression of synaptic proteins and is involved in synaptic plasticity and learning and memory

Sandra Siegert, Ester J Kwon¹, Andrii Rudenko¹, Jinsoo Seo¹, Sukhee Cho¹, Wenyan Wang¹, Zachary Flood¹, Li-Huei Tsai^{1,2}

¹MIT/ The Picower Institute for Learning and Memory, Department of Brain and Cognitive Science, 77 Massachusetts Avenue, Cambridge, MA 02139, USA

²Howard Hughes Medical Institute, Massachusetts Institute of Technology, Cambridge, MA 02139, USA

Schizophrenia is a developmental neurological disorder accompanied by cognitive dysfunction such as deficiencies in working and long-term memory. The origin of this disease is likely to involve epigenetic factors combined with adverse environmental influences. Short, noncoding RNAs, such as microRNAs, are among the top candidates for factors that can be affected by environmental influences, and function by binding to complementary sequences of target mRNAs and repressing translation. MicroRNA137 (miR137) has been implicated in adult neurogenesis and neuronal maturation, but has also been linked to schizophrenia and autistic disorders by genome-wide association studies. Here, we show that miR137 overexpression impacts presynaptic neurotransmitter release, impairs synaptic plasticity, and reduces cognitive performance on an associative memory task. Mice overexpressing miR137 in the dentate gyrus showed normal locomotion and anxiety behavior, as indicated by the open field and elevated plus maze test. However, these mice showed impaired performance in the contextual fear-conditioning task, a hippocampal-dependent test of associative memory. When we assessed long-term potentiation (LTP) by stimulating the mossy fiber pathway and recording from hippocampal area CA3, we found that both short- and long-term potentiation was abolished upon miR137 overexpression. In addition, overexpression of miR137 altered the paired-pulse ratio, suggesting the potential for a presynaptic deficit. Together with our behavioral data, these electrophysiological findings indicate that miR137 may play an important role in the regulation of synaptic function. Accordingly, we analyzed potential synaptic targets of miR137, and found that the vesicular protein synaptotagmin-1 is a miR137 target. Currently, we are investigating synaptic release properties following the overexpression and downregulation of miR137 using imaging and electrophysiological approaches. These ongoing studies are aimed towards elucidating the mechanism by which alterations in miR137 leads to synapse modulation and, as a consequence, to cognitive dysfunction.

From Pattern Generator to Sound Receptor, Hair Cells Adjust Ca^{2+} Signaling to Their Function during Development

Aaron Benson Wong, Mark Allen Rutherford¹, Zhizi Jing¹, Thomas Frank^{1,2}, Tina Pangrsic^{1,3}, Nicola Strenzke^{1,3}, Carolin Wichmann^{1,2}, Tobias Moser^{1,3}

¹InnerEarLab, Department of Otolaryngology, University Medical Center Göttingen, 37075 Göttingen, Germany

²Friedrich Miescher Institute for Biomedical Research, Basel, Switzerland

³Collaborative Research Center 889, University of Göttingen, Göttingen, Germany

Ca^{2+} -triggered transmitter release from cochlear inner hair cells (IHCs) drives pre-sensory and sensory activity in spiral ganglion neurons (SGNs). During postnatal development in mice, IHCs switch from a spontaneously spiking cell to mechanoreceptors which transduce vibration into graded potentials. Although it has been shown that both transmitter release and immature spontaneous action potentials (APs) were mainly mediated through $\text{Ca}_v1.3$ channels, the changes in synaptic Ca^{2+} signal as well as their implication on synaptic transmission were not well documented. Here, we studied the development of IHC Ca^{2+} signaling, afferent synaptic structure and SGN activity in mice.

Using patch-clamp recordings and fast confocal Ca^{2+} -imaging, robust synaptic Ca^{2+} signals driven by spontaneous APs at IHC active zones (AZs) were observed before the onset of hearing. Concomitantly, we found bursting SGN activity *in vivo*, which markedly differed from the Poisson-like spontaneous activity in hearing animals. Immunofluorescence and electron microscopy showed that at each synapse, several small appositions of AZs and postsynaptic densities (PSDs) were initially formed, while after maturation a single AZ/PSD pair was present. Capacitance measurements revealed that coupling between Ca^{2+} influx and vesicle fusion progressively tightened in postnatal IHCs (decrease in apparent cooperativity), while flash photolysis was used to investigate the intrinsic Ca^{2+} dependence of release. In parallel, immunohistochemistry reported a progressive loss of extrasynaptic Ca^{2+} channels. In contrast to the decreasing whole-cell Ca^{2+} current and total channel number, synaptic Ca^{2+} signals increased in strength and heterogeneity, reflecting the emergence of AZs with more Ca^{2+} channels. Computational modeling suggested that these stronger AZs may drive the activity of SGN sub-population with low thresholds and high spontaneous rates.

In conclusion, we characterized the synaptic Ca^{2+} signal associated with naturalistic electric activity of IHCs before and after the onset of hearing, namely, spontaneous APs and receptor potentials. We also demonstrated the presence of bursting activity in the postsynaptic SGNs *in vivo*. The change in IHC function from spiking driver of pre-sensory activity to faithful encoder of graded potentials is accompanied by a confinement synaptic organization and function. Moreover, we propose that maturing IHCs heterogeneously distribute their Ca^{2+} influx among AZs, in order to decompose auditory information to functionally diverse SGNs for encoding for a broad dynamic range of sound pressure.

Abundance of synapsin proteins regulates the size of synaptic vesicles and active zones

Mariya Vasileva, Robert Renden¹, Heinz Horstmann¹, Daniel Gitler², Thomas Kuner¹

¹Universität Heidelberg, Medical Cell Biology, INF 307, 69120 Heidelberg, Germany

² Ben Gurion University of the Negev, Department of Physiology, Faculty of Health Sciences, Beer-Sheva 84105, Israel

Synapsins are abundant neuronal phosphoproteins, associated with the cytoplasmic surface of synaptic vesicles (SVs). In mammals, three distinct synapsin genes encode more than eight neuronal isoforms. Synapsins have been proposed to anchor SVs of the reserve pool thereby forming a cluster of vesicles that are reluctant to release but can be mobilized upon high-frequency stimulation. Synaptic activity disperses synapsins from the vesicle cluster and makes them available to the readily-releasable pool. Here, we correlate the abundance of synapsin expression in the calyx of Held nerve terminal with synaptic morphology and function. We compare three conditions of synapsin abundance: deletion (no synapsin proteins in triple knock-out (TKO) mice), normal synapsin expression (wild type mice) and increased expression (viral overexpression of synapsin Ia).

Deletion of synapsins resulted in lower amounts of the synaptic vesicle protein vGluT1 while the level of the active zone marker bassoon was unchanged in TKO terminals (3D immunohistochemistry of entire calyces). Examination of brain lysates by ELISA revealed a strong reduction in the level of several synaptic vesicle proteins, while proteins of the active zone cytomatrix or postsynaptic density were unaffected. Serial section scanning electron microscopy of large 3D-reconstructed segments confirmed a decrease in the number of SVs to approximately 50% in TKO calyces. Calyces lacking synapsins showed an increased active zone (AZ) size and increased SV diameter. Short-term depression at stimulus frequencies > 100 Hz was accelerated and the time course of recovery from depression was slowed down in calyces lacking synapsins.

Overexpression of synapsin Ia in the naïve rat calyx of Held had opposite effects and led to a decrease of SV diameter, AZ size and redistribution of SV clusters proximal to the AZ. The number of SV at individual AZs was strongly reduced, an effect that can only partially be explained by the reduced AZ size. These structural alterations resulted in accelerated short-term depression at stimulation frequencies exceeding 10 Hz followed by faster recovery. Hence, the reduced density of SV per AZ may impair SV recruitment to the AZ and thereby affect transmission during high-frequency stimulation.

Our data strongly support a model of synapsins organizing approximately 50% of the reserve pool vesicles and their activity-dependent transition into the recycling pool or RRP. The latter mechanism may only account for a small fraction of SV replenishment during high-frequency synaptic transmission. In addition to this 'classical' function of synapsins, we observed that SV and AZ size both scale inversely with the abundance of synapsin proteins: lack of synapsin caused large SVs and AZs while increased expression of synapsin resulted in small SVs and AZs. Hence, we propose that synapsin proteins are prominent regulators of synaptic vesicle biogenesis and active zone size.

Neuroplastin-65 regulates structure and maintenance of excitatory synapses and GABAA receptor localization at inhibitory synapses

Rodrigo Herrera-Molina, Martin Heine², Karl-Heinz Smalla³, Constanze I. Seidenbecher³, Eckart D. Gundelfinger³, Dirk Montag⁴

¹Leibniz Institute for Neurobiology, Neurochemistry and Molecular Biology, Brenneckestraße 6, 39118 Magdeburg, Germany

²Leibniz Institute for Neurobiology, Research Group Molecular Physiology, Brenneckestraße 6, 39118 Magdeburg, Germany

³Leibniz Institute for Neurobiology, Department of Neurochemistry and Molecular Biology and Center of Behavioral Brain Sciences (CBBS), Brenneckestraße 6, 39118 Magdeburg, Germany

⁴Leibniz Institute for Neurobiology, Neurogenetics Special Laboratory, Brenneckestraße 6, 39118 Magdeburg, Germany

The neuronal cell adhesion molecule Neuroplastin-65 (Np65) is highly expressed during formation and stabilization of synapses. In contrast to its smaller splice variant Np55, it is regulated by neuronal activity and potentially mediates adhesion between synaptic membranes via homophilic trans-interactions. Moreover, Np65 can interact with GABAA receptors, which might target these neurotransmitter receptors to synapses. Here, we compared formation and stability of dendritic protrusions and excitatory and inhibitory contacts, and GABAA receptor distribution in hippocampal neurons derived from Neuroplastin-deficient (Np^{-/-}) and wild-type (Np^{+/+}) mice. We observed increased numbers and length of filopodia-like dendritic protrusions in Np^{-/-} neurons at 7-12 days in vitro (DIV). At 21 DIV, Np^{-/-} neurons displayed less excitatory postsynaptic structures matching presynaptic sites. The Np^{-/-} phenotype was confirmed using function-blocking recombinant Np65-Fc extracellular fragment, which also led to decreased matching between excitatory post- and presynaptic structures in Np^{+/+} neurons. Coincidentally, Np65-Fc, but not Np55-Fc, was found to be associated with synaptic sites of CA1 and DG neurons, which highly expressed endogenous Np65. Interestingly, the number of inhibitory synapses was unchanged in Np^{-/-} neurons and in Np65-Fc-treated Np^{+/+} neurons but the excitatory-to-inhibitory synapse ratio was lower in Np^{-/-} than in Np^{+/+} neurons. On the other hand, Np^{-/-} neurons exhibited less co-localization of GABAA receptor alpha-subunits and the vesicular inhibitory amino acid transporter VIAAT as compared to wild-type neurons. Finally, functional consequences of the mutation were revealed by evaluating mEPCs and mIPSCs using patch-clamp recording. Our data indicate that Np65 is a promising candidate to mediate both structural integrity of excitatory synapses and correct synaptic localization of GABAA receptors.

Membrane targeting of collybistin is required for gephyrin clustering at inhibitory postsynapses

Simone Mayer, Tolga Soykan¹, Nils Brose¹, Heinrich Betz^{2,3}, Theofilos Papadopoulos^{1,2}

¹Max Planck Institute of Experimental Medicine, Department of Molecular Neurobiology, Hermann-Rein-Str. 3, 37075 Göttingen, Germany

²Emeritus Group Inhibitory Synapse Formation, Max Planck Institute for Brain Research, 60528 Frankfurt am Main, Germany

³Max-Planck Institute for Medical Research, Jahnstrasse 29, 69120 Heidelberg, Germany

Collybistin (Cb) is a brain-specific guanine nucleotide exchange factor (GEF) that interacts with gephyrin, a scaffolding protein essential for the anchoring of postsynaptic glycine receptors (GlyRs) and gamma-aminobutyric acid receptors (GABA_ARs) to the subsynaptic cytoskeleton. Data from mice carrying an inactivated Cb gene indicate that Cb is required for the formation and maintenance of gephyrin and gephyrin-dependent GABA_AR clusters at inhibitory postsynapses in selected regions of the mammalian forebrain. The molecular mechanisms through which Cb specifies the formation and stabilization of inhibitory postsynapses are not well understood. It has been previously shown that Cb activates the small Rho-like GTPase Cdc42. However, the GEF-activity of Cb towards Cdc42 is not required for inhibitory synapse formation. In contrast, the interaction of Cb with phosphatidylinositol-3-phosphate [PI(3)P] seems to be essential for the formation of inhibitory postsynapses, since the substitution of arginine residues in the PH domain of Cb that are required for PI(3)P binding abrogates the ability of Cb to recruit gephyrin to postsynaptic sites. PI(3)P is known to be enriched in subdomains of the endosomal system, suggesting that the Cb-PI(3)P interaction confers a first layer of specificity for Cb's subcellular targeting. Here, we show that downregulation of hVps34, the major endosomal PI(3)P-synthesizing enzyme, in neurons reduces gephyrin clustering at inhibitory postsynapses. Furthermore, we demonstrate that the PI(3)P binding PH-domain of Cb interacts with the small Rho-like GTPase TC10. Consistent with an important role of this interaction in gephyrin clustering, the co-expression of GTP-bound TC10 with Cb results in efficient recruitment of gephyrin to submembranous microclusters.

The role of Neurobeachin and SAP102 Interaction in the synapse

Fatima Farzana, Juliane Lauks¹, Ruud Toonen¹, Matthijs Verhage¹

Dept. of Functional Genomics,
Center for Neurogenomics and Cognitive Research,
Neuroscience Campus Amsterdam,
VU University Amsterdam
Amsterdam
The Netherlands

Neurobeachin (Nbea) is a multidomain scaffold protein abundant in the brain, where it is highly expressed during development. We found that Nbea controls the trafficking of membrane proteins to both, pre- and post- synaptic sites in central synapses. Neurons deficient for Neurobeachin have >50% reduced glutamate and GABA responses and a concomitant reduction in surface expression of glutamate and GABA-receptors. Immature AMPA-receptors accumulate early in the biosynthetic route and mature NMDA, Kainate and GABA receptors do not reach the synapse. Maturation and surface expression of other proteins, as well as synapse formation and presynaptic functions are unaffected in these neurons.

Using mass spectrometry we have identified Synapse-Associated Protein 102 (SAP 102), a membrane-associated guanylate kinases (MAGUK) protein implicated in trafficking of AMPA- and NMDA-receptors during synaptogenesis, as a novel Nbea interacting protein in mouse brain. Experiments in heterologous cells confirmed the interaction and revealed that SAP102 binds to the C-terminal part of Nbea. We found that a mutation E2218R in Nbea's PH domain abolishes this binding.

To understand how Nbea regulates glutamate receptor transport and membrane-incorporation via its interaction with SAP102, we rescued Nbea-null neurons with this point mutation and analysed glutamate and GABA-responses. Vice-versa, we analysed whether Neurobeachin localization is affected in SAP102 knock-out mice.

Reference:

Neurobeachin Regulates Transmitter Receptor Trafficking to CNS Synapses

Ramya Nair, Juliane Lauks, SangYong Jung, Nancy E. Cooke, Heidi de Wit, Nils Brose, Manfred W. Kilimann, Matthijs Verhage & JeongSeop Rhee (Accepted in JCB)

THE CHOLINERGIC MODULATION OF LAYER 6A PYRAMIDAL CELL IN THE SOMATOSENSORY 'BARREL' CORTEX DEPENDS ON THEIR AXONAL PROJECTION PATTERN

Robert Heinz Günter, Gabriele Radnikow¹, Dirk Feldmeyer^{1,2,3}

¹Institute for Neuroscience and Medicine, INM-2, Research Centre Jülich, D-52425 Jülich, Germany. ²Department of Psychiatry and Psychotherapy and Psychosomatics, Medical School, RWTH Aachen University, D-52074 Aachen, Germany and ³Jülich Aachen Research Alliance, Translational Brain Medicine (JARA Brain).

Acetylcholine (ACh) plays an important role in sleep-wake-transitions. The concentration of ACh in the neocortex increases during wakefulness and becomes maximal in periods of sustained attention. Neocortical ACh release enhances signal processing by increasing the amplitude and reducing the signal-to-noise ratio of sensory responses. Up to now it is known that larger sensory responses are caused by a persistent increase in the excitability of all cortical excitatory neurons except spiny neurons in layer 4 (L4).

Layer 6 (L6), the second major target region of thalamic input, is suggested as a modulator of sensory input and can be subdivided in two sublayers, L6A and L6B. Thalamic innervation is mainly found in the upper part of layer 6A and for that reason chosen as our region of interest.

Two main groups of excitatory neurons can be found in L6A, so called cortico-cortical (CC) and cortico-thalamic neurons (CT). Neurons of these groups can be distinguished by their axonal projection pattern. While the axon of CT neurons targets the thalamic nuclei and projects predominantly within their home column, the axon of CC pyramidal cells has long range collaterals within layer 6 that interconnect adjacent brain areas.

We performed whole cell recordings with simultaneous biocytin fillings of L6A excitatory neurons in ex-vivo brain slices of rats (aged P17 -P21) before, during and after the application of ACh to analyse cholinergic modulation. Specific blockers were used to identify the ACh -receptors underlying the response. The morphology of biocytin-filled neurons was reconstructed to distinguish both L6A pyramidal cell subtypes.

Excitatory neurons in upper L6A showed either a depolarising or a hyperpolarising response to ACh application. The type of voltage response was closely correlated to the axonal arborisation pattern of these neurons. Similar to pyramidal neurons in other cortical layers, L6A CT pyramidal cell depolarised in response to acetylcholine while L6A neurons of the CC type displayed a hyperpolarising response, in a fashion observed for L4 spiny neurons. Both the de- and the hyperpolarising effects were mediated by muscarinic ACh receptors (mAChRs) and not by nicotinic AChRs.

Experiments with pirenzepine (M1 blocker) and tropicamide (M4 blocker) suggested that the depolarising effect of CT neurons is mediated by mAChR subtype M1 whereas the hyperpolarising of CC pyramidal cells is mediated by M4 AChRs, as found for L4 spiny neurons.

The data suggests differential modulation of L6A pyramidal neurons depending on their postsynaptic target structures. On acetylcholine release the activity of the CT pathway is enhanced while the CC signal flow is reduced.

Molecular regulation of Ca²⁺-dependent neurotrophin secretion in hippocampal neurons by CAPS1

Robert Eckenstaler, Thomas Munsch¹, Tanja Brigadski¹, Volkmar Leßmann¹

¹Institute of Physiology, Otto von Guericke University, Leipziger Straße 44, 39120 Magdeburg, Germany

The mammalian neurotrophin Brain-derived neurotrophic factor (BDNF) is an important regulator of a variety of brain functions including neuronal development, survival and synaptic plasticity. The protein is stored in secretory granules and is released upon specific patterns of electrical activity which also induce long-term potentiation (LTP) of glutamatergic synaptic transmission. Although the activity-dependent secretion of BDNF is assumed to be a key element for the induction of synaptic plasticity processes in neurons, the molecular mechanisms of secretory granule exocytosis in neurons largely remained elusive.

We have now investigated the relevance of the priming factor CAPS1 for the release of BDNF-containing secretory granules in hippocampal neurons from mice. Dissociated hippocampal cultures were transfected with plasmids coding for BDNF-GFP and shRNA directed against CAPS1. The depolarisation-induced fusion pore opening of secretory granules and release of BDNF-GFP was analysed by monitoring the intragranular GFP-fluorescence intensity using time lapse video microscopy. The characteristics of fusion pore opening were studied in the presence of the low-molecular weight dye bromphenol blue which rapidly diffuses into vesicles after fusion pore opening, thereby quenching intravesicular fluorescence of BDNF-GFP. In addition, the role of CAPS1 during transmitter release from synaptic vesicles was analysed by destaining of the styryl dye FM1-43. In our hippocampal neurons, CAPS1 immunoreactivity was colocalized with BDNF-GFP in dendritic postsynaptic structures as well as with the presynaptic marker protein VAMP. CAPS1 knockdown had an inhibitory effect on transmitter release. The rate of transmitter release was significantly reduced by 28.6 ± 3.1 % after CAPS1 knockdown. However, the average size and density of synaptic boutons were unchanged. In addition, the fusion pore opening of secretory granules was affected by CAPS1 knockdown. The number of fusion pore opening events of BDNF-GFP containing secretory granules was significantly reduced 57.3 ± 6.2 % in hippocampal neurons transfected with CAPS1 shRNA. Although the average size of single vesicles and their BDNF-GFP loading was not changed by CAPS1 knockdown, the intragranular pH value was significantly higher in hippocampal neurons transfected with the CAPS1 shRNA.

The present results suggest that endogenous CAPS1 plays an important role in regulating, both, synaptic vesicle exocytosis as well as secretory granule exocytosis and that CAPS1 has an additional function in the regulation of vesicular pH.

This project was funded by the DFG GRK1167 and the DFG LE 1020/1.

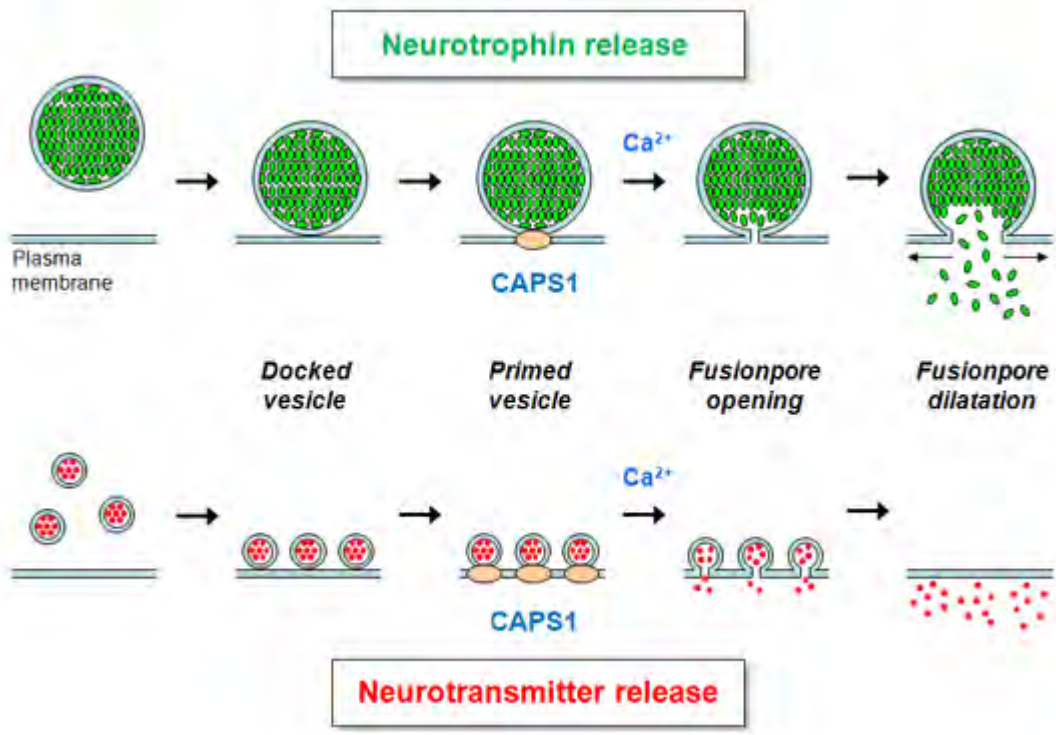

Mechanisms underlying heterogeneity of Ca^{2+} signaling among hair cell active zones

Tzu-Lun Wang, Mark.A. Rutherford¹, Tobias Moser¹

¹ Inner Ear Lab, Dept. of Otolaryngology and and Sensory Collaborative Research Center 889, Universität Medizin Göttingen, Robert-Koch-Str. 40, 37075 Göttingen, Germany

Sound intensity is encoded as the firing rates of spiral ganglion neurons. These neurons show different rate-level functions and are thought to collectively encode the large dynamic range of the auditory stimuli. We investigated the heterogeneous properties of presynaptic Ca^{2+} microdomains and their relationship to synaptic ribbons. We tried to explain how hair cells decompose auditory information at their heterogeneous ribbon synapses driving neurons with different rate-level functions.

Postnatal (14-18 days) mouse inner hair cells from the apical half-turn of the organ of Corti were voltage clamped in whole-cell mode. A fluorescent Ca^{2+} indicator (Fluo-8FF) and a ribbon reporter (TAMRA-conjugated CtBP2-binding peptide) were perfused into the hair cells via the pipette solution. Step or ramp depolarization protocols were used to evoke Ca^{2+} influx and analyze the resulting Ca^{2+} microdomains. A spinning disk confocal microscope was used to image each cell in 3D, and to characterize each Ca^{2+} microdomain over time.

Synaptic Ca^{2+} microdomains and ribbons exhibited strong heterogeneity, and their fluorescence intensities were positively correlated. Additionally, we assessed the spatial distribution of ribbon and Ca^{2+} hotspot intensities within individual inner hair cells. Larger ribbons and stronger Ca^{2+} microdomains tended to localize to the modiolar (neural) side.

Our results imply that larger synaptic ribbons are associated with more Ca^{2+} channels, which is expected to enhance neurotransmitter release at those synapses. Interestingly, previous studies (Merchan-Perez & Liberman, 1996) on cat cochlea suggested that high spontaneous rate auditory nerve fibers mainly innervate the pillar (abneural) face of inner hair cells. If conserved among species our finding of weaker Ca^{2+} microdomains on the pillar face seems in conflict with this view. Further investigation is required to solve this apparent discrepancy.

Extra Cellular Matrix differently affects mobility of AMPA receptors in spiny and aspiny synapses

Yulia Klyueva, Renato Frischknecht², Martin Heine³

Leibniz Institute for Neurobiology ,

¹Department of neurochemistry,

²Extracellular matrix

³Molecular physiology,

Brennekestrasse 6, 39118 Magdeburg, Germany

AMPA receptors constitutively move in and out synapses and have a significant impact on the effectiveness of synaptic transmission and plasticity. In excitatory neurons glutamatergic synapses localize on membrane protrusions known as dendritic spines enwrapped by a loose extracellular matrix (ECM). Inhibitory neurons mostly have glutamatergic synapses present on the shafts of the dendrite that are often enwrapped by dense form of ECM. How the structural discrepancies and different matrix distribution between spiny and aspiny neurons influence lateral mobility of AMPA receptors remains unclear. Using fluorescence recovery after photo bleaching (FRAP) and single particle tracking (SPT) we show that the mobile fraction of AMPA receptors is larger in aspiny than in spiny synapses. Patch-clamp recordings combined with fast iontophoretic application of Glutamate revealed slower recovery from desensitization, faster kinetic and higher rectification index at aspiny synapses compared to spiny in hippocampal cultures, which reflect differences in subunit composition of AMPA receptors between spiny and aspiny neurons. Lower content of GluA2 subunits in AMPA receptors at aspiny synapses was confirmed by immunocytochemistry and partial block of the currents by Philantotoxin 433. Acute digestion of the ECM with hyaluronidase increased to a higher extent lateral mobility of synaptic and extrasynaptic AMPA receptors on shafts than on spines measured in FRAP and SPT experiments. Corroborating this fact, digestion of the ECM speeded up the recovery from desensitization and increased paired-pulse ratio at the half of spiny synapses. The same time ECM digestion slowed down kinetic parameters and had no effect on recovery from desensitization and paired pulse ratio at the majority of shaft synapses. In contrast to spiny synapses, where cross-linking of AMPA receptors by antibody led to the longer recovery from desensitization and robust decrease in the paired pulse ratio, it had no more effect on the slow recovering shaft synapses. These results confirm the idea that the mobility of differently assembled at shaft and spiny synapses AMPA receptors could be differently affected by the ECM. Lateral diffusion, playing important role in short-term and long-term plasticity, is restricted at the excitatory synapses not only by the ECM but also by spine itself, whereas on shaft synapses ECM and dense matrix can play a similar role, preserving the subunit receptors composition at the synapse by restriction of lateral receptor diffusion.

Gene expression profiling of globular bushy cells during synaptic maturation

Christoph Körber, Anna Dondzillo¹, Gisela Eisenhardt², Oliver Wafzig², Thomas Kuner¹

¹Heidelberg University, Institute of Anatomy and Cell Biology, Im Neuenheimer Feld 307, 69120 Heidelberg, Germany

²SYGNIS Bioscience, Im Neuenheimer Feld 515, 69120 Heidelberg, Germany

Neurons undergo specific, cell type dependent morphological and functional changes during development that are reflected in changes in their gene expression profile. Here we correlate the changes in gene expression in a specific cell type, the globular bushy cells (GBCs) of the anterior ventral cochlear nucleus (aVCN), with the changes in the properties of synaptic transmission during postnatal maturation from day 3 (P3) to P21. This developmental period is characterized by fundamental changes in both, synaptic morphology and function, as it includes the onset of hearing at ~P11 and the achievement of nearly mature firing patterns at P10. The GBCs give rise to the calyx of Held, a giant axosomatic synapse in the contralateral medial nucleus of the trapezoid body (MNTB) of the auditory brainstem. The calyx initially contacts the principal cell of the MNTB at P2 and develops from this so called proto-calyx into a cup-shaped synapse which later on fenestrates to achieve its mature morphology. These morphological changes are paralleled by a number of functional changes that optimize the synapse for high fidelity, high frequency synaptic transmission and include e.g. decreases in action potential (AP) half-width and synaptic delay as well as increases in active zone and synaptic vesicle number.

Gene expression profiles of GBCs of different maturational stages were obtained by selective retrograde labelling of GBCs with Cholera toxin B (ChTx) coupled to Alexa488. To achieve this, ChTx was stereotaxically injected into the MNTB of rats at P2, P8 and P20. Labelled GBCs in the contralateral aVCN were harvested 24h after injection by laser micro dissection and subjected to Affimetrix GeneChip profiling. The specificity of the labelling was confirmed by recording of the firing pattern as well as reconstructing the morphology of labelled cells.

Comparison of the expression profiles between developmental stages yielded 2093 genes regulated between P3 and P9 (940 up, 1153 down) and 1372 genes regulated between P9 and P21 (678 up, 694 down). When comparing the extreme stages of P3 when the calyx has just formed to the adult synapse at P21, we found a total of 7315 genes regulated (3387 up, 3928 down). This number is by far greater than the sum of genes regulated from P3 to P9 and from P9 to P21. Thus, a large number of genes was only slightly regulated over a rather long period, which prevented them from being classified as regulated when comparing either P3 or P21 with P9 data. Among the developmentally regulated genes, we found a large number that has been implicated in the optimization of both, AP propagation and synaptic transmission, for high frequency firing, such as voltage activated sodium and potassium channels (up-regulated e.g. Na_v 1.1, $Nav\beta$ 4, K_v 3.1, K_v 3.3; down-regulated e.g. Na_v 1.2, $Nav\beta$ 3, K_v 4.2, K_v 4.3), synaptic calcium buffers (calretinin and parvalbumin up-regulated) and proteins of the endocytic machinery (up-regulated e.g. dynamin1 and 3, synaptojanin1, amphiphysin2, clathrin light chain b, AP1 B-subunit).

In summary, we, for the first time, correlate the developmental changes in gene expression with the changes of firing properties and synaptic neurotransmission in a defined cell type of the central nervous system.

Functional and dynamic properties of dendritic versus perisomatic inhibition in hippocampal neuronal networks

Shakuntala Savanthrapadian, Imre Vida², Marlene Bartos¹

¹Physiologisches Institut I, Albert-Ludwigs-Universität Freiburg, Hermann-Herder-Straße 7, 79104 Freiburg, Germany

²Institute for Integrative Neuroanatomy, Charite Berlin, Phillipstraße 12; 10115 Berlin, Germany

Computation in cortical networks depends on the balance between excitation and inhibition (Isaacson and Scanziani 2011, Neuron 72). Timed inhibition on specific somatodendritic domains of GABAergic neurons is needed to control the integration of their excitatory inputs and spike output. On the network level these functions support the generation of network oscillations and the recruitment of synchronously active principal cell assemblies (Klausberger et al. 2003, Nature 421). In the dentate gyrus, the primary input region of the hippocampus, a variety of inhibitory neurons are present which could participate in these tasks. These include perisoma-inhibiting interneurons (PIIs), proximal dendrite-inhibiting hilar commissural/associational pathway associated (HICAP) interneurons and distal dendrite-inhibiting hilar perforant pathway associated (HIPPA) interneurons. Of these interneurons, the specific functions and contributions of the dendrite inhibiting interneurons (DIIs) still remain unclear. To address this question, we performed paired whole-cell recordings of synaptically connected DIIs in hippocampal slices to determine the functional and dynamic characteristics of synaptic GABA_A receptor-mediated signalling. Cells were labelled during recordings for subsequent morphological evaluation. Our data indicate that in contrast to strong, fast and reliable inhibitory signalling among PIIs (peak amplitude, 101 ± 35 pA; latency, 1.4 ± 0.2 ms; failure rate, 2 ± 2 %; decay, 3.9 ± 0.8 ms), GABAergic transmission among mutually connected HICAP and HIPPA cells is characterized by significantly weaker strength (HICAP pairs, 21 ± 11 pA; HIPPA pairs, 7 ± 0.2 pA), higher failure rates (HICAP pairs, 58 ± 7 %; HIPPA pairs, 45 ± 15 %) and markedly slower time courses (HICAP pairs, 7.2 ± 1.2 ms; HIPPA pairs, 15.2 ± 1.8 ms) which may be explained by marked electrotonic attenuation and deceleration of synaptic signals (Nörenberg et al. 2010, PNAS 107). DIIs also demonstrate unique dynamic characteristics in their inhibitory signalling in response to 50 Hz trains. HICAP pairs show a continuous facilitation during the course of the train while HIPPA pairs demonstrate an initial facilitation followed by depression. Coefficient of variance analysis indicates that both dynamic patterns are mediated by presynaptic mechanisms. Furthermore, DIIs also inhibit PIIs, such that the reliability and dynamics of inhibitory signalling are significantly affected by the identity of the presynaptic cell. In summary, our data show distinct kinetic and dynamic properties of compartment-specific dendritic inhibitory synapses. They further indicate a domain-specific inhibitory control of pathway-specific excitatory inputs onto target cells. Dendritic inhibition of interneurons could in effect 'disinhibit' the principal cell population specifically during activation by inputs from distinct extrahippocampal pathways. However, the precise roles of DIIs in controlling information processing will be the main focus of our future investigations.

Regulation of presynaptic Ca^{2+} influx during trains of action potential-like stimuli

Kun-Han Lin, Holger Taschenberger¹

¹Max Planck Institute for Biophysical Chemistry, Dept. of Membrane Biophysics, Am Fassberg 11, 37077 Göttingen, Germany

During repetitive synapse activation, synaptic strength can be rapidly adjusted. Synaptic vesicle depletion and changes in release probability are the key mechanisms underlying this short-term synaptic plasticity. Because transmitter release is highly nonlinearly related to the intraterminal Ca^{2+} concentration, even minute changes in presynaptic Ca^{2+} influx can strongly influence release probability. At the calyx of Held, a large glutamatergic synapse that allows direct presynaptic patch-clamp recordings, at least three mechanisms that reduce presynaptic Ca^{2+} influx through voltage-gated Ca^{2+} channels (VGCCs) have been identified: (1) extracellular Ca^{2+} depletion from the synaptic cleft by activation of Ca^{2+} -permeable ion channels, (2) Ca^{2+} -dependent Ca^{2+} current inactivation (CDI), and (3) feedback inhibition of VGCCs via G-protein coupled receptors (GPCRs). Here we studied how these three pathways of presynaptic Ca^{2+} current attenuation are recruited during trains of action potential-like depolarizations of various frequencies.

To separate CDI from mechanisms that require glutamate release from the terminal, we recorded presynaptic Ca^{2+} currents ($I_{\text{Ca(V)}}$) with botulinum toxin in the pipette solution and in the presence of a cocktail of antagonists blocking the activation of both ionotropic Ca^{2+} -permeable GluR channels as well as metabotropic GluRs. Under these conditions, inactivation of $I_{\text{Ca(V)}}$ during trains of presynaptic depolarizations was greatly diminished indicating that CDI plays only a minor role. Inactivation of $I_{\text{Ca(V)}}$ during low-frequency stimulation (5–10 Hz) was highly sensitive to manipulations that block the action of GPCRs whereas such treatment had little effect on the degree of inactivation of $I_{\text{Ca(V)}}$ measured during short high-frequency trains (100–200 Hz). In contrast, inactivation of $I_{\text{Ca(V)}}$ during high-frequency trains was strongly attenuated when blocking postsynaptic Ca^{2+} -permeable GluR channels but insensitive to GPCR antagonists. Taken together our results suggest that presynaptic $I_{\text{Ca(V)}}$ during action potential-like trains is attenuated primarily by synaptically released glutamate acting on ionotropic and metabotropic GluRs while CDI contributes only little. During synapse maturation, the clearance of released glutamate from the synaptic cleft is accelerated and the number of Ca^{2+} permeable NMDAR channels is reduced. These developmental changes strongly limit the activation of GPCRs and reduce the depletion of Ca^{2+} ions from the synaptic cleft and may thereby explain the significantly reduced inactivation of $I_{\text{Ca(V)}}$ during trains observed in more mature calyx terminals.

Characterisation of the transport of Active Zone proteins to Synapses

Tina Ghelani, Thomas Dresbach¹, Nina Wittenmayer¹

¹University Of Göttingen, Anatomy and embryology, Kreuzberggring 36 , 37075 Göttingen, Germany

The presynaptic cytomatrix is a meshwork of proteins in which synaptic vesicles are embedded. A specialized subcompartment of this meshwork is called the Cytomatrix of Active Zones (CAZ). At the electron microscopy level the CAZ appears as a dense structure composed of filamentous material originating at the active zone plasmamembrane, i.e. the site of neurotransmitter release. Five CAZ-proteins have been identified, including Bassoon, Piccolo, RIM, Munc13 and CAST/ERC. In immature neurons, these proteins are associated with vesicles named Piccolo-Bassoon-transport vesicles (PTVs) which may deliver pre-assembled CAZ-precursors to synapses.

By using fluorescence and electron microscopy we are investigating the transport of PTVs from the Golgi apparatus to synapses in primary hippocampal cultures. We show the localization of CFP-tagged Bassoon via photooxidation driven generation of electron dense diaminobenzidine (DAB)-deposits which were visualized by electron microscopy. This method allows for novel insights into the subcellular localization of recombinant Bassoon. CFP- Bassoon photoconversion results in dark, fuzzy coat surrounding vesicles which appear in clusters in the soma and axon. These data indicate that recombinant Bassoon associates with clear core vesicles in the soma, and that overexpression of Bassoon either promotes the generation of these vesicles or inhibits their exit from the soma. CFP-Bassoon vesicles colocalise with other active zone proteins such as Piccolo and Munc13-1. We see high colocalisation of endogenous CAZ proteins in developing axons of immature neurons, supporting the model that AZ proteins are partially travelling together on specific transport organelles to synaptic sites.

Super resolution imaging of brain-derived neurotrophic factor in synapses of hippocampal neurons *in vitro*

Robert Blum, Thomas Andreska¹, Sarah Aufmkolk², Sebastian van de Linde², Markus Sauer²

¹University of Würzburg, Institute for Clinical Neurobiology, Würzburg, Germany ²Department of Biotechnology & Biophysics, Julius-Maximilians-University Würzburg, Würzburg, Germany

The neurotrophin brain-derived neurotrophic factor (BDNF) is a modulator of synaptic morphology, synaptic efficiency and neuronal plasticity. BDNF acts through its high-affinity receptor TrkB (tropomyosin-receptor kinase B). At several key synapses of the trisynaptic hippocampal circuit activity-dependent secretion of BDNF influences long-term potentiation, a cellular correlate of learning and memory. There is increasing evidence that disturbed hippocampal BDNF signaling and secretion is involved in the development of severe mood disorders such as depression and anxiety in humans. A polymorphism in the human BDNF gene (Val⁶⁶Met) has been found to be associated with reduced regulated secretion of BDNF thus affecting its functionality in fear learning and emotional disorders. Downstream phosphorylation cascades induced by BDNF release are beginning to be well defined, while attempts to localize BDNF release sites in adult central neurons were complicated by the low amounts of endogenous BDNF normally found in adult neurons. Thus, neuronal cultures from rodents became a routine tool to investigate BDNF synthesis, trafficking, synaptic steady-state localization and BDNF-release sites. Numerous studies mimicked BDNF trafficking and release with recombinant BDNF or tagged-versions of BDNF upon recombinant overexpression. Most of these studies came to the conclusion that BDNF is stored and released from axonal and dendritic compartments. Some studies using GFP-tagged versions of BDNF propose that postsynaptic secretory granules at glutamatergic synapses are a preferential release site of BDNF. These data are in striking contrast to recent and earlier data that visualize endogenous BDNF in brain sections and come to the conclusion that BDNF exerts its action on postsynaptic neurons by anterograde release from presynaptic sites.

We took up this controversy and investigated the steady-state localization of endogenous BDNF in hippocampal neurons (>21 days old). The neurons exhibit pre- and postsynaptic specializations and react with sustained network-driven, glutamate receptor-dependent oscillations in Ca²⁺ upon short term depolarization. We first screened 12 different antibodies and identified one monoclonal anti-BDNF antibody that provides a high labeling density at synapses, is background free on BDNF-deficient hippocampal neurons and colocalizes with a second, independently verified polyclonal anti-BDNF serum. High-resolution confocal microscopy shows strong BDNF labels close to glutamatergic synapses. However, confocal microscopy was not able to ultimately resolve BDNF within the fine structure of synapses. Thus, we used super resolution imaging by direct stochastic optical reconstruction microscopy (*dSTORM*) allowing us to perform colocalization analysis of two independent immunolabels with precision in the range of 10 nm. *dSTORM* images identified BDNF in small granule-like vesicles within presynaptic glutamatergic terminals. Quantitative analysis calculated more than 40% and up to 60% of all BDNF imaging signals in an x-y area that was encircled by immunoreactivity signals of a presynaptic marker for glutamatergic synapses (vGlut). Little amounts of BDNF were found close to postsynaptic, homer-positive synaptic bars (about 5%). In conclusion, super resolution imaging of endogenous BDNF supports concepts of anterograde release of BDNF from glutamatergic synapses.

dSTORM images of hippocampal synapses *in vitro*

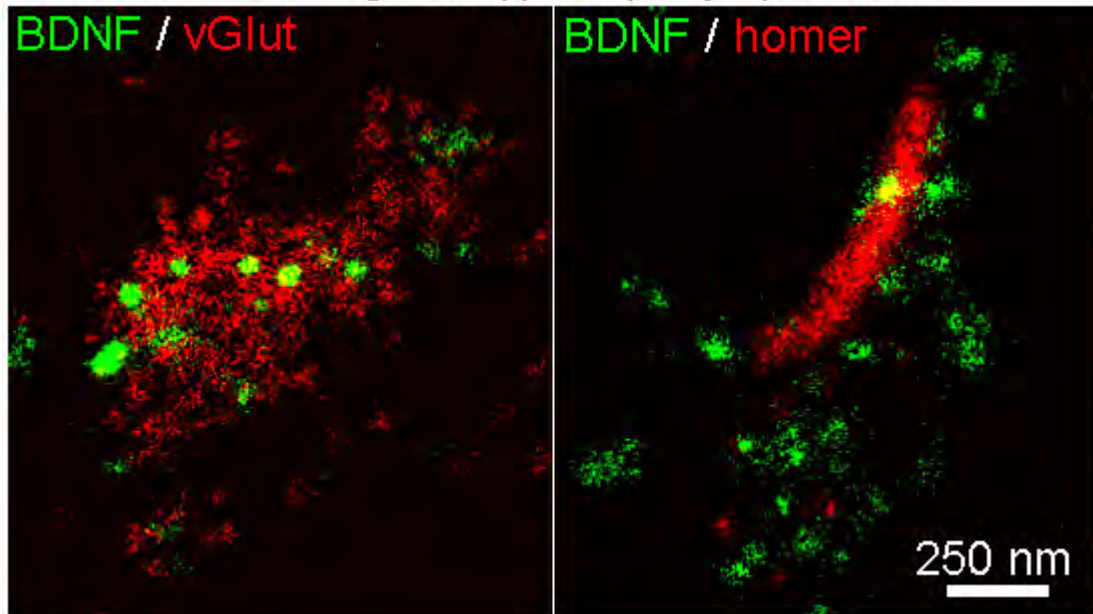

Analysis of compartment-specific and cell autonomous loss-of-function of MeCP2

Avani Shukla, Oliver Schlüter¹

¹European Neuroscience Institute- Göttingen, Molecular Neurobiology, Grisebach Str. 5, 37077 Göttingen, Germany

Rett syndrome (RTT) is a postnatal neurological disorder which affects 1 in 10,000 females. It is characterized by normal development till 6-18 months of age, followed by an onset of developmental stagnation and progressive decline in cognitive functions. Using mouse models of Rett syndrome, it has been established that a functional loss of MeCP2 (methyl-CpG-binding protein-2) causes RTT. The X-linked MECP2 gene encodes for a protein that mediates transcriptional repression by means of chromatin remodeling. To perform a thorough analysis of MeCP2 loss-of-function on synaptic function, I use pathway-specific optical stimulation and cell-restricted manipulations of MeCP2. I established a viral system of shRNA-mediated knockdown of MeCP2 and overexpression of channelrhodopsin, in individual neurons. This allows the analysis of cell-autonomous alterations specific to the neuronal pre- and post-synaptic compartment for specific synaptic connections.

Dendritic origin of axons in CA1 pyramidal neurons

Christian Thome, Tony Kelly², Maren Engelhardt³, Martin Both¹, Sidney Cambridge⁴,
Andreas Draguhn¹, Heinz Beck², Christian Schultz³, Alexei V. Egorov¹

¹Institute of Physiology and Pathophysiology, University of Heidelberg, Germany

²Department of Epileptology, University of Bonn, Germany

³Center for Biomedicine and Medical Technology Mannheim, University of Heidelberg, Germany

⁴Institute for Anatomy and Cell Biology, University of Heidelberg, Germany

Neurons are classically described as highly polarized cells with a dendritic input region, signal integration in the soma and axonal output. In this scheme, the axon initial segment (AIS) is usually located immediately adjacent to the cell soma. However, recent evidence has revealed complex functions of the AIS in signal processing, including activity-dependent changes in excitability and morphology. Here we report an unusual location of AIS at basal dendrites of principal hippocampal neurons which might cause asymmetric input processing.

We analyzed the functional architecture of murine CA1 pyramidal cells. These excitatory projection neurons provide a major output pathway from the hippocampus. Cell morphology was visualized with Alexa-488 (filling by whole-cell recording) or DsRed (Brainbow 2.0 line O; Livet et al, 2007) and immunostaining of the AIS performed with antibodies against ankyrin-G or β 4-spectrin. Quantitative analysis revealed that about 50% of axons originated from a basal dendrite, instead of the soma. About half of these axon-carrying dendrites showed additional branching points proximal to the axon initial segment. The highest prevalence of axon-carrying dendrites was found in the middle portion of CA1, while there were much less axons branching off dendrites in CA3 or in the subiculum. Computer simulations suggest that the axon-carrying basal dendrite is functionally privileged: action potential threshold is reached more easily upon depolarization of this dendrite. Simulations of somatic shunting indicated that excitatory input to the axon-carrying dendrite is much less sensitive to perisomatic GABAergic inhibition than input to "normal" dendrites. Experiments utilizing multiphoton glutamate uncaging revealed that basal dendrites carrying axons were more likely than simple dendrites to trigger action potentials and exhibit dendritic spikes.

Taken together, our data reveal a surprisingly frequent dendritic origin of axons of CA1 pyramidal neurons. The resulting subpopulation might be important for signal integration and assembly formation in this hippocampal network.

Supported by the German Ministry of Education and Research (BMBF, 01GQ1003A, BCCN Heidelberg-Mannheim).

Compartmentalization and single cell anatomy of a larval peptidergic circuit in *Drosophila melanogaster*

Gergely Karsai, Christian Wegener³, Gergely Berta², László Molnár¹, Edit Pollák¹

¹Department of General Zoology, University of Pécs, Hungary

²Department of Medical Biology, University of Pécs, Hungary

³Department of Neurobiology and Genetics, Theodor-Boveri Institute, Biocenter, University of Würzburg, Germany.

Revealing synaptic connectivity in the nervous tissue is a major goal in neuroscience. Most anatomical dissections of synaptic circuits implicitly assume a clear polarity of neurons, which makes it easy to predict the direction of information flow once pre- and postsynaptic compartments are identified.

It is now interesting to ask whether peptide synthesizing interneurons ("modulatory neurons") are -like other neuron types- polarised and have different functional compartments.

Earlier confocal microscopic observations of peptidergic cell populations in the ventral nerve cord of the fruit fly larva suggested that some parts of peptidergic cells may function as typical dendritic regions with several input surfaces while other neurites represent peptide release sites [1]. However, we lack a detailed fine structural morphological studies of in- and output compartmentalization as well as neural connections indicating synaptic control of peptidergic cells. In part this may be caused since handling samples at this level is posing many methodological challenges.

In *Drosophila*, ecdysis-controlling peptidergic CCAP neurons represent a limited number of neurochemically similar but functionally different cells, with differential and subset-specific functional importance [2]. We first analysed the spatial characteristics of the CCAP neurons using GAL4/UAS-directed ectopic expression of GFP-tagged pre- and postsynaptic marker molecules and immunostaining of ectopically expressed CAPA-peptides in the larval CNS. This identified putative in- and output compartments, but overlapping structures made it impossible to identify the polarity of each individual cells. We therefore applied the flip-out technique and dissected the branching pattern of the larval CCAP neurons down to the single cell level.

In order to correlate the distribution of GFP-tagged synaptic markers with the ultrastructure, we are currently comparing our data obtained by confocal laser scanning with immuno-electron microscopy. Advantages and drawbacks of different methods employed in the morphological analysis of a selected model peptidergic cell population are discussed.

[1] Santos et al. 2007 PLoS ONE 2:e695. [2] Luan et al. 2006 J Neurosci 26:573.

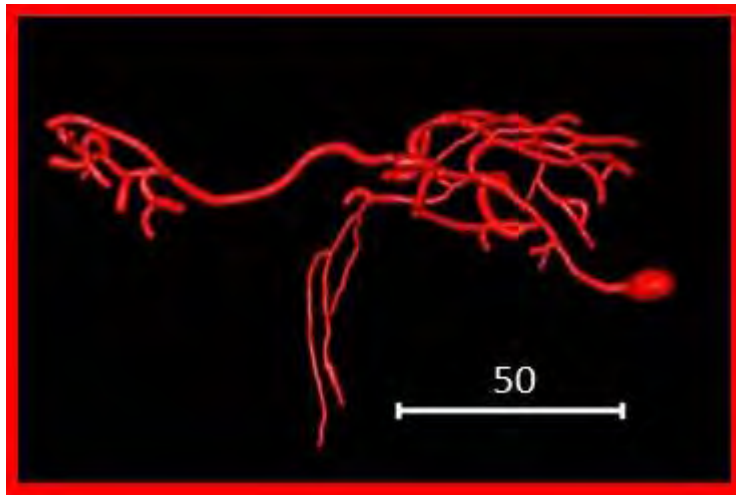

A new vertebrate-specific presynaptic protein as molecular component of the endbulb of Held

Friederike Wetzel, Thomas Dresbach¹

¹University of Göttingen, Anatomy and Embryology AG Synpatogenesis, Kreuzberggring 36, 37075 Göttingen, Germany

The endbulb of Held's exceptional size has made it an important model system for the study of synaptic transmission. Furthermore, the structure of the endbulb of Held has been extensively studied to gain more insight into the process of synaptic differentiation. However, little is known about the molecular composition of endbulbs of Held. We have recently identified Mover, a vertebrate-specific 266 kDa protein, as a component of the calyx of Held. Here, we have begun to study the molecular composition of endbulbs of Held with a particular focus on vertebrate-specific presynaptic proteins, assuming that this relatively small family of proteins may confer specific features to specialized presynaptic nerve terminals. To initiate this study, we characterized the localization of Mover within the auditory pathway. Using immunohistochemistry we find abundant Mover immunoreactivity in auditory nuclei of the brainstem, e.g. the cochlear nucleus, lateral superior olive, medial nucleus of the trapezoid body, inferior colliculus. In the anteroventral cochlear nucleus (AVCN) the immunoreactivity for Mover exhibits a punctate pattern surrounding the somas of bushy cells. The pattern of Mover is similar compared to other synaptic markers, i.e. Synapsin or Synaptophysin, but not to a glia cell marker, i.e. glial fibrillary acidic protein (GFAP). To further examine the cellular localization of Mover in presynaptic terminals in the AVCN we performed immunofluorescence staining with anti-VGLUT1, anti-VGAT and anti-Mover antibodies. At synaptic terminals ending on bushy cells we find co-localization of Mover with both VGLUT1 and VGAT. Hence, we conclude that Mover is a molecular component of presynaptic endings in the anteroventral cochlear nucleus, including the endbulbs of Held.

CHARACTERIZATION OF THE FUNCTIONAL DOMAINS OF A NOVEL PRESYNAPTIC PROTEIN: MOVER

Asha Kiran Akula, Saheeb Ahmed², Camin Dean², Thomas Dresbach¹

¹Georg August Universität Göttingen, Anatomy, Kreuzberggring 36, 37075 Göttingen, Germany

²European Neuroscience Institute, Göttingen

Mover (also called TPRGL and SVAP30) is a novel vertebrate specific presynaptic protein that has been identified as a binding partner for the presynaptic scaffolding protein Bassoon in a yeast-2-hybrid assay. Mover exhibits differential distribution among synapses of the central nervous system, suggesting that Mover may play a role in generating functional heterogeneity among synapses. Moreover, exon 2 of Mover appears to be alternatively spliced, giving rise to a long and a short isoform of Mover. Preliminary data suggests that Mover is targeted to presynaptic nerve terminals and co-localizes with the synaptic vesicle protein Synaptophysin and with Bassoon. Mover is partly soluble and partly membrane bound in biochemical assay. As Mover has been recently identified, little is known about its expression, regulation and function. The aim of this study is to begin to characterize the functional domains of Mover and their role in targeting to presynaptic nerve terminals. Recombinant full length Mover is found to be targeted to synapses and shows co-localization with Synaptophysin, Synapsin and Synaptobrevin. To this end, four recombinant GFP-Mover deletion constructs were constructed with deletions introduced either at both N- and C-terminus, within the HSac2 homology domain or deleting Exon2. Upon over-expression of the above mentioned recombinant Mover GFP deletion constructs in cultured hippocampal neurons, we found that deleting the N-terminal 50 amino acids did not impair targeting, but deleting Exon2 or the HSac2 domain impaired targeting. In addition we found that a short C-terminal peptide was required for targeting.

This suggests that the short isoform of Mover does not undergo presynaptic targeting; moreover a short C-terminal peptide is crucial for the association of Mover with presynaptic nerve terminals.

Changes in the synchrony of cross-synaptic output of a retinal neuron

William N Grimes, Fred Rieke¹

¹HHMI/UofWa, Physiology and Biophysics, 1705 N.E. Pacific Street, 98195 Seattle, USA

Specific patterns of synchronous signaling within neural networks shape the efficacy of synaptic transmission, the development of highly-specific wiring configurations and computations that rely upon correlated network activity. Correlations in spontaneous network activity (i.e. in the absence of stimulus correlations) are driven by divergent output from upstream signaling/circuit components. Cross-synaptic synchrony -- correlations in transmitter release across output synapses of a single neuron—underlies network noise correlations and is a key determinant of the noise sources that limit the fidelity of signals traversing a neural circuit, yet it has been technically challenging to study cross-synaptic synchrony separately from other forms of synchrony. The anatomical connectivity between the rod bipolar and A17 amacrine cells in the mammalian retina provides a rare opportunity to make direct measurements of cross-synaptic synchrony under near-physiological conditions.

Unlike many neurons in the CNS, rod bipolar cells do not produce all-or-none spikes in presynaptic membrane potential, a mechanism for synchronizing transmitter release across synaptic boutons/outputs. Instead rod bipolar cells, in addition to many other sensory neurons, convey visual signals via graded changes in membrane potential. In the absence of a synchronizing mechanism, such as action potentials, it is largely unclear how synchronized output synapses would be under physiological conditions. By combining a quantitative inner-retinal wiring assessment with electrophysiological recordings from pairs of highly-overlapping A17 amacrine cells we assess the cross synaptic synchrony of the rod bipolar cell's output across a range of physiological conditions. We find that the output synapses of individual rod bipolar cells are near-perfectly synchronized in the dark, thus faithfully transmitting upstream signals and noise to all postsynaptic targets. Dim background lights desynchronize release, which causes a fundamental, but also reversible, change to the inputs to downstream circuit components.

Novel genetic mouse model for Bassoon and Piccolo allowing functional studies in developing and adult brain

Sabrina Müller, Anil Annamneedi¹, Anna Fejtová¹, Eckart D. Gundelfinger¹

¹Leibniz Institute for Neurobiology, Department Neurochemistry and Molecular Biology, Brenneckestraße 6, 39118 Magdeburg, Germany

The chemical synapse is a highly specialised compartment of a neuron. It is designed for efficient transmission of signalling information between the neurons and their target. The basic events for neurotransmitter release are priming and fusion of synaptic vesicles to the plasma membrane. These processes are restricted to a specialised area of the membrane of presynapse called the active zone (AZ). AZ is determined by presence of a electron-dense structure named cytoskeletal matrix assembled at the AZ (CAZ). Two important proteins within the CAZ are Bassoon and Piccolo. They are proposed to spatially and functionally organize the neurotransmitter release (1). They are large proteins sharing a high sequence homology leading to a number of common interaction partners and highly overlapping cellular functions. Knockout mice for Bassoon have shown strong epileptic seizures, impairment of vision and hearing, and a reduction of life expectancy (2-3). These severe phenotypes prevent the performance of behavioural studies. Deletion of both Bassoon and Piccolo is essential to address their functional redundancy. However, constitutive double knockout for both Bassoon and Piccolo die within several hours, which restrict the possibility of functional analysis in this model. For this reason we generated a constitutive knockout mice for Bassoon where exon 2 is floxed. The transcription start codon is located in exon 2 and the excision of this exon leads to a frame shift of the coding DNA of the Bassoon gene downstream. To use the capacity of the Bassoon conditional gene targeting it is necessary to choose Cre transgenic mouse strains in which Cre activity is tightly controlled in space and time. We chose the Emx1-Cre (4) that is expressed in excitatory neurons of the telencephalon during embryogenesis to study the effect of Bassoon deletion on neurite outgrowth and synaptogenesis during the early development. On the other hand, we used the CamKII-Cre mouse strain (5) that express Cre at P15 in the same brain areas for assessing the postnatal effects of the knockout of Bassoon in a mature brain networks, where synapse formation was not affected by deletion of Bassoon. In case that Cre-driven deletion of Bassoon in telencephalon in Piccolo knockout background would be lethal or show a strong phenotype preventing functional analysis we additionally established a more sophisticated inducible knockout using SLICK V-Cre system (6). The knockout of Bassoon is here triggered in random subpopulation of neurons throughout the brain by injection of Tamoxifen which can be given at any time point of development and also in adult mice. These genetic strategies allow us to finally create a system, where effect of double knockout of Bassoon and Piccolo can be investigated in physiological circuits.

1. E. D. Gundelfinger, A. Fejtova, *Curr Opin Neurobiol* 22, 423 (Jun, 2012).
2. W. D. Altmann et al., *Neuron* 37, 787 (Mar 6, 2003).
3. O. Dick et al., *Neuron* 37, 775 (Mar 6, 2003).
4. J. A. Gorski et al., *J Neurosci* 22, 6309 (Aug 1, 2002).
5. L. Minichiello et al., *Neuron* 24, 401 (Oct, 1999).
6. P. Young et al., *Nat Neurosci* 11, 721 (Jun, 2008).

Presynaptic targeting of Mover involves a self-interaction domain

Thomas Dresbach, Asha Kiran Akula¹, Nina Wittenmayer¹, Jan Höber¹

¹University of Goettingen Medical School, Center of Anatomy, Synaptogenesis Group, Kreuzbergring 36, 37075 Goettingen, Germany

Neurotransmission at chemical synapses occurs at specialized sites of the presynaptic plasma membrane called active zone. At these sites, synaptic vesicle proteins act in concert with active zone proteins to provide the machinery responsible for the regulated fusion of synaptic vesicles with the presynaptic plasma membrane and synaptic vesicle recycling. Mover (also called TPRGL and SVAP30) is a vertebrate specific 266 kDa protein that has been found in a yeast-two hybrid screen using the cytomatrix of the active zone scaffolding protein Bassoon as bait. Initial studies found Mover to be differentially localized to subsets of mature presynapses in the central nervous system. Here, immunocytochemistry of developing hippocampal neurons shows endogenous Mover to be colocalized with Bassoon and synaptic vesicle proteins prior to synapse formation in cell culture, raising the question as to what trafficking mechanisms are involved in Movers localization to presynapses and at what step Mover becomes associated with presynaptic organelles. With the help of a yeast-2-hybrid screen, in conjunction with a cell-based optical assay of homo-oligomerization, we find that Mover undergoes homophilic interactions, whereas regions within both the N- and C-terminus of the protein are required for this interaction. Transfection of hippocampal neurons with Mover deletion constructs that are unable to homomers resulted in a complete loss of recombinant Mover at presynaptic terminals compared to wild type Mover. Taken together, these data delineate two distinct targeting domains in Mover and suggest that homo-oligomerization is crucial for its presynaptic localization.

GABA related proteins persist beyond the developmental GABA to glycine shift at inhibitory auditory brainstem synapses of mice

Alexander Fischer, Jennifer Smuda¹, Matthew A. Xu-Friedman², Eckhard Friauf¹,
Désirée Griesemer¹

¹TU Kaiserslautern, Biology Department, Animal Physiology Group, Erwin-Schrödinger-Str. 13, 67663 Kaiserslautern, Germany;

²University at Buffalo, Department of Biological Sciences, 109 Cooke Hall, Buffalo, NY 14260

While GABA is the main inhibitory neurotransmitter in the cerebral cortex its presence in the brainstem is sparse. Yet one exception is the highly organized inhibitory projection from the medial nucleus of the trapezoid body (MNTB) to the lateral superior olive (LSO) within the auditory brainstem. Due to its unique structural features this projection is a favorable model system for inhibition, compared to diffuse interneuronal connectivity of cortical brain regions. It has been described for rats (Kotak et al., J Neurosci, 1998) and gerbils (Nabekura et al., Nat Neurosci, 2004) that the MNTB-LSO synapse undergoes a transition from a predominantly GABAergic to a glycinergic character until the end of postnatal week two. However, a detailed description in mice is still lacking. To reveal the relative contribution of GABA- and glycine-mediated inhibition whole-cell voltage-clamp recordings were obtained from LSO principal neurons in acute brainstem slices of mice at postnatal day (P) 4 ± 1 and $P11 \pm 1$. Both transmitter systems were pharmacologically isolated during electrical stimulation of MNTB fibers. In addition potential extrasynaptic modes of GABAergic inhibition were tested during focal pressure application of GABA. Despite a much earlier developmental shift towards glycinergic transmission (90% at P4; 100% at P11) compared to rats and gerbils, we found that many GABA-related proteins, like GABA_ARs, GABA_BRs and GABA transporters (GATs) are still functional present in pre- and extrasynaptic locations of the LSO at P11. While repetitive pressure application of GABA (24 pulses at 0.2 Hz) at P11 displayed constant amplitudes of 820 ± 71 (1st pulse) to 773 ± 63 pA (24th pulse), pharmacological treatment with specific GAT blockers (GAT1: NO-711 & GAT3: SNAP5114) resulted in a strong depression by 55 ± 4 % (1st vs. 24th pulse; $p < 0.001$). Concomitantly, the average current decay time significantly increased 3.4-fold from 265 ± 23 to 904 ± 77 ms ($p < 0.001$). GAT1 or GAT3 blocker alone displayed no or only mild effects (depression: 17 ± 4 %, $p < 0.001$; decay time: 1.6-fold increase, $p < 0.001$), suggesting a mutual compensation of both transporters. Since the observed GABA_A-mediated currents were not completely blocked by the GABA_AR antagonist GABA_Azine, we further investigated if GABA_BRs also contribute to postsynaptic inhibition. Preliminary experiments revealed that LSO neurons are indeed sensitive to the GABA_BR agonist baclofen. Potential expression of presynaptic GABA_BRs was also tested in an exclusively presynaptic calcium imaging assay. Application of baclofen during MNTB fiber stimulation resulted in a significant decrease (20.1 ± 3.3 %, $p < 0.01$) of presynaptic calcium influx. Given the functional presence of postsynaptic GABA_{A/B}- and presynaptic GABA_B- receptors, together with GAT1 and GAT3 dependent modulation of GABAergic currents during focal transmitter application in the LSO, we will now focus on GAT-dependent modulation of synaptic (glycinergic) transmission at the MNTB-LSO synapse.

Mechanisms of neurotransmitter release at the inner hair cell ribbon synapses

Nikolai M. Chapochnikov, Hideki Takago², Elisabeth Auge⁴, Caroline Wichmann⁴,
Tobias Moser^{2,3}, Fred Wolf^{1,3}

¹Department of Nonlinear Dynamics, Max Planck Institute for Dynamics and Self-Organization, Am Faßberg 17, 37077 Göttingen, Germany

²InnerEarLab, Department of Otolaryngology, University of Göttingen Medical School, Robert-Koch-Strasse 40, 37075 Göttingen, Germany

³Bernstein Center for Computational Neuroscience, University of Göttingen, 37073 Göttingen, Germany

⁴Molecular Architecture of Synapses Junior Research Group, University of Göttingen Medical School, Robert-Koch-Strasse 40, 37075 Göttingen, Germany

Inner hair cell (IHC) ribbon synapses encode sound via the temporal pattern of vesicle exocytosis. Although EPSCs recorded in auditory nerve fibers (ANF) are known to be highly heterogeneous in shape and amplitude, almost each EPSC reliably triggers an action potential. This is supported by their very large amplitude (mean ~300 pA). The large amplitude and heterogeneity of EPSCs was attributed to the fact that IHC ribbon synapses synchronize the release of multiple neurotransmitter quanta (multiquantal release, MQR) in the absence of presynaptic spiking.

This unconventional mode of exocytosis challenges the traditional framework of synapse functioning. Two alternative scenarios have been proposed for how MQR is accomplished: (1) Release site-coordination/coupling, which could be biophysically realized by synchronized exocytosis of multiple vesicles triggered by a Ca²⁺-nanodomain from a single channel and (2) compound exocytosis fueled by vesicle-to-vesicle fusion. Here we combine multiple modeling and experimental approaches to study the mechanism of exocytosis at IHC ribbon synapses.

For mechanism (1), using biophysical modeling we found that a [Ca²⁺] concentration above 0.2 mM is required at the release site to reproduce the synchrony and efficacy of MQR. We thus performed patch clamp recordings of ANF boutons at 0 and 1.3 mM exterior [Ca²⁺]. In the 0 mM condition, the mean EPSC amplitude and charge were decreased by about two-fold and the fraction of multiphasic EPSCs was reduced. However, EPSCs with amplitudes up to several hundreds of pA persisted, suggesting that Ca²⁺-synchronized exocytosis is unlikely to be the mechanism triggering high amplitude EPSCs.

The model of mechanism (2) predicts that during synaptic activity, the majority of synaptic vesicles at the active zone would be multiquantal (mean diameter at least twice larger than the one of uniquantal vesicles). Using high-pressure freeze electron microscopy, we measured the diameter distribution of ribbon-associated vesicles in inhibited and stimulated IHC ribbon synapses. After inhibition, the mean diameter was 36 ± 4 nm. After 15 min stimulation, the mean diameter increased by ~10 % and only ~2% of vesicles exceeded 70 nm (twice the uniquantal vesicle diameter). This slight increase in vesicle size seems insufficient to account for MQR.

We thus examined a fundamentally different release mechanism that is shaped by vesicle fusion pore dynamics and that relies on uni-/subquantal release. Using modeling, we show that this scenario could account for experimental observations at IHC ribbon synapses. In fact, their large glutamate postsynaptic receptor clusters seem well-suited to generate large EPSCs even for uniquantal release. In addition, small and multiphasic EPSCs can result from one and multiple short pore openings, respectively. To further test this interpretation, we analyzed the multiphasic EPSC shapes. Our deconvolution suggests that these EPSCs are more compatible with a uni-/subquantal interpretation rather than with a MQR one.

Analysis of the balanced state in a 2-population network by mean-field theory

Alexander Schmidt, Fred Wolf^{1,2,3}, Michael Monteforte^{1,2,3}

¹Georg-August-University, Goettingen, Germany

²Max Planck Institute for Dynamics and Self-Organization, Goettingen, Germany

³Bernstein Center for Computational Neuroscience, Goettingen, Germany

We analyse the firing rate distributions of sparsely connected, externally driven neuronal networks with an inhibitory and an excitatory population in the balanced state. For the excitatory population we implement two different receptor types by superpositioning single receptor kernels and include the possibility to change their ratio continuously.

Therefore, we study heterogeneous networks with gaussian distributed threshold inhomogeneity. Phasediagrams of different statistical parameters are obtained to examine the predicted firing rate distributions and dark matter transitions. Throughout our work, we introduce weight parameters to scale the impact of the inter- and intrapopulation's current inputs and analyse the resulting differences in the firing rate distributions of the inhibitory and excitatory populations. The different temporal and quenched variances of the populations, as well as the networks dependence on them are examined.

We find that the synaptic timeconstants of the inhibitory and excitatory current input strongly influence the networks behaviour. Applying different receptor types changes the temporal and quenched variances and, especially for evenly mixed receptors, one observes big regions of dark distributions.

Properties of Synaptic Transmission at a Corticothalamic Giant Synapse in Mice

Francisco José Urra Quiroz, Thomas Kuner¹

¹ Institute of Anatomy and Cell Biology, Dept. of Functional Neuroanatomy, Universität Heidelberg, Im Neuenheimer Feld 307, 69120, Heidelberg¹

The thalamus relays sensory information from the periphery to the cortex, but also links primary to secondary sensory cortices. Layer 5B (L5B) pyramidal neurons of the somatosensory cortex connect via relay neurons of the posteromedial nucleus (POm) to neurons of higher order somatosensory cortex. Synaptic transmission between L5B pyramidal neurons and POm relay cells is mediated by a giant synapse harboring multiple synaptic contacts. This 'Rosebud' synapse acts as a driver synapse in situations of low spontaneous activity of the L5B neuron, but can also function as a coincidence detector at high activity levels. To place the functional properties of this synapse in the context of behavioral abilities developing during the first two months of postnatal life, it is required to know the profile of changes in structure and function during that time period.

We labeled Rosebud giant terminals by stereotaxic delivery of adeno-associated virus particles encoding synaptophysin-EGFP into the somatosensory cortex of mice (ages P2 - P20). Rosebud giant terminals in mice of different ages were identified in the POm and directly stimulated with a double-barrel electrode after establishing whole-cell patch-clamp recordings from the postsynaptic relay neurons (mice ages P10-P60). This allowed us to study the maturational changes in synaptic transmission of identified rosebud giant synapses.

Voltage-clamp recordings of POm relay cells at different ages, at a holding membrane potential of -60 mV, revealed a postsynaptic current amplitude of approximately 0.2 nA in response to single terminal stimulation. The amplitude of spontaneous activity shows similar values starting from the second week, but the frequency of the spontaneous activity decreased over time: from 6 Hz at the second week, to 2 Hz at week six. Upon high-frequency stimulation, the EPSCs showed a strong frequency-dependent short-term depression starting with the 4th postnatal week. This may result in a low-pass filtering of incoming signals thereby limiting the bandwidth of information transfer. The NMDA/AMPA composition also was analyzed at different ages. The AMPA/NMDA ratio tended to increase over time. Finally, we found that the number of branches of the relay cells tended to decrease after the 2nd postnatal week.

In conclusion, Rosebud synapses exhibit minor changes in structure and function during the first weeks of postnatal maturation. In comparison to the rat Rosebud synapse, the amplitude of the EPSC was markedly smaller yet sufficient to drive the postsynaptic neuron. The mouse Rosebud synapse appears to attain adult properties already early in postnatal life.

Functional changes of presynaptic Active Zone induced by endogenous Amyloid beta

Maria Andres-Alonso, Vesna Lazarevic^{1,2}, Eckart Gundelfinger¹, Anna Fejtova¹

¹Leibniz Institute for Neurobiology, Neurochemistry and Molecular Biology, Brenneckestraße, 6, 39118 Magdeburg, Germany

²German Center for Neurodegenerative Disorders (DZNE), Magdeburg Branch, Magdeburg, Germany

Amyloid beta (Abeta) is a key player in the development of Alzheimer's disease. Recently it was suggested to contribute to synaptic plasticity by regulating the efficacy of presynaptic neurotransmitter release in healthy brain. The major aim of this study is to investigate molecular and cellular mechanisms underlying Abeta-induced modulation of presynaptic efficacy. Thereby we focused on Abeta-driven structural and functional remodeling of presynaptic active zone. We used primary cortical neurons as convenient cellular model accessible for the modulations of basal Abeta level by pharmacological manipulations and allowing investigation using biochemical and imaging methods. Treatment of cortical cells either with the Neprylisin antagonist thiorphan (TH) to elevate endogenous Abeta levels or by inhibition of secretase BACE responsible for APP processing to reduce them, revealed fast and robust regulation of presynaptic composition and function by Abeta. Strikingly, elevated endogenous Abeta level (that is still within the physiological range) induce the rearrangement of distinct presynaptic scaffolds and synaptic vesicle proteins and increases the efficacy of neurotransmitter release in cortical synapses. Furthermore, we could show that increased synaptic vesicles release probability is dependent on activation of alpha-bungarotoxin-sensitive nicotinic receptors (alpha7nAChR), presence of Ca²⁺ in cultured medium and ongoing network activity. Our study bring new knowledge regarding synaptic function of Abeta in normal, physiological conditions, which help us to better understand the effects of its chronic elevation on synaptic failure that precedes cognitive decline in AD.

C-terminal Binding Protein 1: a novel neuronal metabolic sensor involved in the activity-dependent gene expression

Anika Dirks, Daniela Ivanova¹, Cornelia Schoene¹, Denny Schanze², Anna Fejtova¹,
Eckart D. Gundelfinger¹

¹Leibniz Institute for Neurobiology, Dept. of Neurochemistry and Molecular Biology, Brenneckestraße 6, 39118 Magdeburg, Germany

²Institute for Human Genetics, Leipziger Straße 44, 39120 Magdeburg, Germany

C-terminal Binding Protein 1: a novel neuronal metabolic sensor involved in the activity-dependent gene expression

Anika Dirks, Daniela Ivanova, Cornelia Schoene, Diana Huebler, Denny Schanze*, Anna Fejtova and Eckart D. Gundelfinger

Leibniz Institute for Neurobiology (LIN), Magdeburg, Germany

*Institute for Human Genetics, Magdeburg, Germany

C-terminal Binding Protein 1 (CtBP1) is a multifunctional protein having nuclear and cytoplasmic functions. In mammals CtBP1 gene locus codes for two protein isoforms: CtBP1-L (long) and CtBP1-S/BARS50 (short). As a transcriptional co-repressor CtBP1 is essential for the normal animal development and cell differentiation. In cytoplasm CtBP1-S/BARS 50 drives the fission of membrane vesicles in the endocytic and exocytic pathways that do not require dynamin. CtBP1 binds to NAD and NADH and this binding stimulates the interaction of CtBP1 with its interaction partners. In promoting binding NADH was reported to be several orders of magnitude more effective than NAD. Thus changes in the intracellular NAD/NADH ratio, reflecting the metabolism state of the cell, modulate binding of CtBP1 to its target proteins. In neurons CtBP1 can interact with the two highly homologous components of the presynaptic cytomatrix at the active zone- Bassoon and Piccolo and was found to be localized to cell bodies and synapses. We found that the synapto-nuclear distribution of CtBP1 was strongly regulated by synaptic activity and that modulation of global network activity in turn significantly influenced the intracellular NAD/NADH levels. The pharmacological modulation of both neuronal activity and cellular NAD/NADH levels affected the molecular dynamics of CtBP1 at synapses assessed by fluorescence recovery after photobleaching imaging. One way in which neuronal activity and cellular metabolic state might modulate the synaptic dynamics of CtBP1 is via regulating its interaction with the synaptic scaffolding proteins Bassoon and Piccolo. Indeed we discovered the changes in the NAD/NADH ratio significantly affected the interaction between CtBP1 and Bassoon, as revealed in a CoIP analysis. To further prove the hypothesis of Bassoon- and Piccolo dependent anchoring of CtBP1 to the synapse we demonstrated that the sub-cellular localization of CtBP1 critically depends on expression of Bassoon and Piccolo. In neurons depleted for both Piccolo and Bassoon CtBP1 was not present at synapses. Moreover, the CtBP1 nuclear levels were elevated in these neurons, which led to changes in the CtBP1-controlled gene expression. Thus, the Bassoon and Piccolo function as a synaptic anchor for CtBP1, which might be dynamically regulated by metabolic status of the cells. Taken together, we identified a novel cellular pathway, in which overall metabolic status controls neuronal activity-dependent modulation of gene expression.

Support: Deutsche Forschungsgemeinschaft (GRK1167, AL1115/1)
CBBS/ZVOH and LSA

Poster Topic

T8: Synaptic Plasticity, LTP, LTD

- T8-1A** Heterosynaptic plasticity at neocortical pyramidal neurons: mechanisms and possible role in neuronal networks
Marina Chistyakova, Chris Lee, Jen-Yung Chen, Maxim Bazhenov, Maxim Volgushev
- T8-2A** Activity dependent processing of Brevican by extracellular proteolysis
Jeet Bahadur Singh, Juan-Carlos Valenzuela, Eckart D. Gundelfinger, Constanze Seidenbecher, Renato Frischknecht
- T8-3A** Role of metabotropic glutamate receptor subtype 5 in synaptic plasticity and cognition
Hamdy Shaban, Marie Pollard, Erik De Prins, Thomas Steckler
- T8-4A** Global deprivation of BDNF reveals its cell type-specific effect on neuronal architecture
Anita Remus, Marta Zagrebelsky, Martin Korte
- T8-5A** Dendrite structure and synaptic plasticity are altered in the hippocampus of cortactin knockout mice
Kristin Michaelsen-Preusse, Melissa O'Brien, Ulrike Herrmann, Klemens Rottner, Martin Korte
- T8-6A** Electrical activation of the locus coeruleus induces hippocampal LTD in the dentate gyrus
Niels Hansen, Denise Manahan-Vaughan
- T8-7A** Nogo-A orchestrate actin dynamics within dendritic spine of mature hippocampal neurons
Yves Kellner, Martin E. Schwab, Martin Korte, Marta Zagrebelsky
- T8-8A** MicroRNA expression in the barrel cortex after sensory stimulation
Ines Khadimallah, Nathalie Wenger, Rudolf Kraftsik, Romano Regazzi, Guylène Kirschmann, Egbert Welker
- T8-1B** Electrophysiological characterization of the inhibitory MNTB-LSO connection upon prolonged high frequency stimulation: the effect of intermittent stimuli
Martin Fuhr, Eckhard Friauf
- T8-2B** "Functional Role of Metabotropic Group I Glutamate Receptors in Synaptic Plasticity at Granule Cell – Basket Cell Synapses"
Thomas Hainmüller, Akos Kulik, Marlene Bartos
- T8-3B** Mossy fiber – CA3 and associational/commissural CA3 synapses reveal differences in the protein synthesis-dependency of persistent plasticity in vivo
Hardy Hagera, Denise Manahan-Vaughan

- T8-4B** Pheromonal regulation of synaptic plasticity in the mushroom-body calyx during adult behavioral maturation in the honeybee
Thomas Sebastian Muenz, Claudia Groh, Alban Maisonnasse, Kornelia Grübel, Yves Le Conte, Wolfgang Rössler
- T8-5B** Long-term plasticity at the olfactory bulb mitral – granule cell synapse
Mahua Chatterjee, Fernando Pérez de los Cobos Pallarés, Veronica Egger
- T8-6B** Ependymin: Expression studies of a Microheterogeneous Sialoprotein in the Nervous System
Donato Penninella, Rupert Schmidt
- T8-7B** Enhancement of cholinergic output in *C. elegans* by the *Beggiatoa* sp. photo -activatable adenylyl cyclase.
Wagner Steuer Costa, Jana Fiona Liewald, Peter Hegemann, Alexander Gottschalk
- T8-8B** Dissecting the mechanisms of long-term depression in visual cortex.
Plinio das Neves Favaro, Oliver M. Schlüter
- T8-1C** Differential pre- and postsynaptic contribution to t-LTP expression in hippocampal CA1 region depends on induction paradigm
Martin Wilhelm Erich Franck, Volkmar Leßmann, Elke Edelmann
- T8-2C** Metaplasticity by ryanodine receptor activation promotes the recovery of synaptic impairments in the APP/PS1 mouse model of Alzheimer's disease
Qin Li, Martin Korte, Sreedharan Sajikumar
- T8-3C** Effects of a spatial learning task on the mammalian ependymin related protein (MERP).
David Hinchliffe, Rupert Schmidt
- T8-4C** Dynamics of the synaptic fucosyl proteome
Nicole Höche, Karin Richter, Thilo Kähne, Wolfgang Tischmeyer, Karl-Heinz Smalla, Daniela C. Dieterich
- T8-5C** Nogo-A signaling plays a major role in modulating dendritic spine dynamics in CA3 hippocampal neurons
Marta Zagrebelsky, Martin E. Schwab, Martin Korte
- T8-6C** Norepinephrine Gates Hippocampal Std-Ltp By Potassium Channel Inactivation
Yanling Liu, Oliver M Schlueter
- T8-7C** Alteration of inhibitory feedback mechanisms in the cochlea and dorsal root ganglion by KCC2 and NKCC1 after injury. A model for neuropathic pain and tinnitus?
Dario Campanelli, Annalisa Zuccotti, Wibke Singer, Lukas Rüttiger, Jeremy Tsung-Chieh Chen, Jing Hu, Marlies Knipper
- T8-1D** Analysis of conditional APP/APLP2 double knock-out mice reveals a strong hippocampal CA3-CA1 LTP defect
Ulrike Herrmann, Meike Hick, Ulrike Müller, Martin Korte

- T8-2D** Synaptopodin regulates denervation-induced homeostatic synaptic plasticity of dentate granule cells in mouse entorhino-hippocampal slice cultures.
Andreas Vlachos, Benno Ikenberg, Maximilian Lenz, Kurt Reifenberg, Carlos Bas Orth, Thomas Deller
- T8-3D** mGluRs contribute to somatic $[Ca^{2+}]_i$ rises elicited in cerebellar molecular layer interneurons by parallel fiber stimulation in vivo
Jin Bao, Guadalupe Astorga, Abdelali Jalil, Jonathan Bradley, Isabel Llano
- T8-4D** Repetitive magnetic stimulation induces coordinated functional and structural changes of excitatory postsynapses in mouse entorhino-hippocampal slice cultures
Maximilian Lenz, Johannes Rosskopp, Ulf Ziemann, Thomas Deller, Florian Müller-Dahlhaus, Andreas Vlachos
- T8-5D** Regional metabolite distribution in the human corpus callosum
Sabine Hofer, Jens Frahm
- T8-6D** Recruitment of BDNF signaling in hippocampal mossy fiber LTP induced by different high frequency stimuli
Elke Edelmann, Petnoi Petsophonsakul, Angela Jahn, Sandra Schildt, Volkmar Leßmann
- T8-7D** Dopaminergic regulation of spike -timing dependent plasticity in CA1 of the hippocampus depends on the induction protocol
Efrain A Cepeda, Elke Edelmann, Volkmar Leßmann

Heterosynaptic plasticity at neocortical pyramidal neurons: mechanisms and possible role in neuronal networks

Marina Chistyakova, Chris Lee¹, Jen-Yung Chen², Maxim Bazhenov², Maxim Volgushev¹

¹University of Connecticut, Psychology, 406 Babbidge road, 06269 Storrs, USA

²Department of Cell Biology and Neuroscience, University of California, Riverside, CA, USA

Spike-timing dependent plasticity (STDP) and other conventional Hebbian-type plasticity rules are prone to produce runaway dynamics of synaptic weights. Once potentiated, a synapse would have higher probability to lead to spikes and thus to be further potentiated, but once depressed a synapse would tend to be further depressed. Heterosynaptic plasticity may solve this problem by complementing plasticity at synapses that were active during the induction, with opposite-sign changes at non-activated synapses. A potential candidate mechanism for normalization is plasticity induced by purely postsynaptic protocol, intracellular tetanisation. We show that modifications at synapses to layer 2/3 pyramidal neurons from rat visual and auditory cortices in slices can be induced by intracellular tetanization: bursts of spikes evoked by short depolarizing pulses applied to postsynaptic cell without presynaptic stimulation. Intracellular tetanisation could induce either potentiation, or depression, or did not change the strength of synaptic inputs. The proportion of inputs which underwent LTP, LTD or did not change after intracellular tetanisation was comparable in the visual cortex (42%, 33% and 25%) and in the auditory cortex (28%, 42% and 30%). The direction of plasticity correlated with the initial release probability: inputs with initially low release probability tended to be potentiated, while inputs with high release probability tended to be depressed. Thus, intracellular tetanisation had a normalizing effect on synaptic efficacy.

Induction of plasticity by intracellular tetanisation required rise of intracellular $[Ca^{++}]$, because it was impaired by chelating intracellular calcium with EGTA. The long-term changes induced by intracellular tetanisation involved both pre- and postsynaptic mechanisms. EPSP amplitude changes were correlated with changes of release indices: paired pulse ratio and the inverse of the coefficient of variation (CV-2). Presynaptic components of plastic changes were abolished in experiments with blockade of NO-synthesis and spread, indicating involvement of NO-signalling.

We suggested that this type of plasticity may serve as a mechanism that normalizes synaptic weights and prevents their runaway dynamics. To test this hypothesis, we developed a cortical neuron model, in which homosynaptic plasticity was implemented as STDP, and heterosynaptic plasticity was implemented to match the observed experimental data. In the model with STDP alone, correlated spike trains induced runaway synaptic dynamics over a broad range of STDP parameters and input patterns. Runaway dynamics manifested itself as saturation of all or a significant portion of synaptic inputs at maximum or minimum weights. Heterosynaptic plasticity effectively prevented runaway dynamics for the tested range of STDP and input parameters. Synaptic weights, although shifted from the original, remained normally distributed and non-saturated within their operating range.

Our experimental and theoretical results show that heterosynaptic plasticity induced by intracellular tetanization may prevent runaway synaptic dynamics but keep synaptic weights unsaturated and thus susceptible for further plastic changes.

Activity dependent processing of Brevican by extracellular proteolysis

Jeet Bahadur Singh, Juan-Carlos Valenzuela¹, Eckart D. Gundelfinger¹, Constanze Seidenbecher¹, Renato Frischknecht¹

¹Leibniz Institute for Neurobiology, Magdeburg, Germany, Extra cellular matrix, Neurochemistry, Brennecke street 6 , 39118 Magdeburg, Germany

The extracellular matrix (ECM) of the brain appears at the second postnatal week and embeds proximal dendrites and the axon initial segments of many neurons in a mesh-like structure that interdigitates with synaptic contacts. Removal of the ECM using the glycosidase hyaluronidase (Hyase) that digests hyaluronic acid, the backbone of the ECM alters short-term plasticity in dissociated hippocampal neurons. Maintenance of long-term potentiation (LTP) is dramatically impaired in brevicin mutants, a phenotype that can be mimicked by application of anti-brevican antibody. Treatment of hippocampal slices with the bacterial enzyme chondroitinase ABC (ChABC), which removes chondroitin sulfates from CSPGs, leads to a reduction in LTP expression. However, injections of ChABC into the visual cortex in deprived adult rats abolish the ocular dominance and differences in spine densities in the contra-compared to the ipsi-lateral side. These results indicate that on one hand the ECM is blocking synaptic plasticity by stabilizing synaptic contacts and preventing synaptogenesis in the adult, and on the other hand they provide important instructive information necessary for LTP, a measure for synaptic plasticity. Therefore, endogenous mechanisms that alter locally the structure of the ECM may be a mechanism to allow for juvenile plasticity in the adult in a restricted area and time.

The chondroitin sulfate proteoglycan Brevican is one of the main components of the mature ECM. It is the smallest member of the family of lecticans. Together with other proteoglycans or glycoproteins such as tenascin-R the lectican form a tight meshwork around neurons. It has been shown that brevicin and the other lecticans can undergo proteolytic cleavage, mainly by ADAMTS4 (a disintegrin and metalloprotease with thrombospondin motifs). It has been reported that during the first minutes to hours after LTP induction neurons show enhanced structural plasticity. Therefore we wondered whether brevicin as a representative of the ECM is particularly proteolytically cleaved during LTP. To this end we induced chemical LTP in acute slices and performed quantitative western blotting to measure brevicin cleavage. We found a marked increase in brevicin cleavage compared to control slices 15-60 min after LTP induction. Cleavage was reduced to basal level when a broad-spectrum protease inhibitor was used during the experiment. This indeed indicates that proteolytic cleavage and therefore remodeling of the ECM may be involved in learning and memory processes that require structural plasticity.

Role of metabotropic glutamate receptor subtype 5 in synaptic plasticity and cognition

Hamdy Shaban, Marie Pollard¹, Erik De Prins¹, Thomas Steckler¹

¹Janssen Pharmaceutica, Neuroscieicne, Turnhoutsweg 30, 2340 Beerse, Belgium

Metabotropic glutamate receptors (mGluRs) have been implicated in a diverse variety of neuronal Functions related to cognition. Specifically mGluR5 is a key player in modulating synaptic function and plasticity during cognitive tasks.

mGluR5 plays an important role in both long-term potentiation (LTP) and long-term depression (LTD), suggesting that mGluR5 PAMs may also have utility in improving impaired cognitive function. Highly selective positive allosteric modulators (PAMs) of metabotropic glutamate receptor subtype 5 (mGluR5) have emerged as a

potential approach to treat positive symptoms associated with schizophrenia. Here we tested different mGluR5 ligands on multielectrode array in hippocampal brain slices.

DHPG dose dependently decreased basal synaptic transmission where mGluR5 antagonist MTEP and MPEP showed minor changes.

Postive allosteric modulator showed preference to enhancements of LTD.

At the prefrontal cortex brain slice mGluR5 agonist and PAM showed similar effect on neuronal spiking, more experiments would be needed to clarify the role of mGluR5 during cognitive activities.

Global deprivation of BDNF reveals its cell type-specific effect on neuronal architecture

Anita Remus, Marta Zagrebelsky², Martin Korte^{1,2}

¹Helmholtz Zentrum für Infektionsforschung, Neuroinflammation und Neurodegeneration, Spielmannstraße 7, 38106 Braunschweig, Germany

²TU-Braunschweig, Zoologisches Institut, Zelluläre Neurobiologie, Spielmannstraße 7, 38106 Braunschweig, Germany

Many *in vitro* studies indicate that Brain-Derived Neurotrophic factor (BDNF) regulates the neuronal differentiation, synaptic plasticity as well as dendritic arborization. However, as the *bdnf* null mutation leads to death soon after birth, its role during CNS postnatal development is difficult to assess *in vivo*. This question is even more crucial as BDNF levels markedly increase in the postnatal brain. The anterograde axonal transport of BDNF between brain areas complicates the interpretation of previously made areas-specific conditional mouse mutants. We used a new conditional mouse mutant (*cbdntf ko*), provided by Yves-Alain Barde, Basel, in which BDNF is lacking throughout the CNS using the Cre-loxP recombination system under the control of the tau promoter (Rauskolb et al., 2010). These BDNF-depleted animals survive for several months and while the size of their brain is generally reduced, the effect of BDNF deprivation is surprisingly area-specific. The volume of the hippocampus is not affected, while the size of the cortex is reduced by 20% and the volume of the striatum is even smaller by 35%. Detailed analysis of dendritic complexity and spine density in inhibitory medium spiny neurons (MSN) of the striatum showed a highly significant reduction. On the contrary, the analysis of CA1 pyramidal neurons revealed only minimal effects on dendritic branching as well as on spine density, while the proportion of mushroom-type spines is significantly decreased (Rauskolb et al., 2010). The results leave two possible interpretations open: 1) the effect of BDNF could be area-specific (hippocampus vs. striatum) or 2) it could be cell type-specific (excitatory hippocampal pyramidal neurons vs. MSNs in the striatum).

To address this question we compared excitatory neurons in the cortex of wt and *cbdntf ko* mice. The pyramidal neurons of layer II/III and layer V showed no effect on dendritic complexity. However, the spine density and the spine types showed the same reduced proportion of mushroom-type spines as seen for the CA1 pyramidal neurons. Furthermore, we used viral induced BDNF deletion in *bdnf^{flox/flox};tau^{wt}* primary neurons to study the effects of BDNF deletion on inhibitory and excitatory neurons within the same area. Interestingly, BDNF acts in a cell type-specific way to regulate neuronal dendritic architecture. While inhibitory neurons of BDNF depleted cultures of the cortex and hippocampus revealed a highly significant reduced dendritic complexity, the dendritic architecture of excitatory neurons in the same brain areas is not affected. Interestingly, besides BDNF, we found Zinc to be involved in regulating neuronal morphology of excitatory neurons but not of inhibitory neurons. This effect might be achieved via the transactivation of the TrkB receptor in a neurotrophin-independent manner (via Src). The Zinc mediated regulation is different in dendrites and spines. BDNF and Zinc cooperate to regulate dendritic structure, while the spine density can be regulated by either one or the other. In contrast, the spine shape modulation seems to be done exclusively by BDNF.

In summary, BDNF acts in a cell type-specific way to regulate the neuronal architecture. While inhibitory neurons depend on BDNF for their dendritic development, the neuronal morphology of excitatory neurons can be regulated via BDNF activating the TrkB receptor and via Zinc possibly through the transactivation of the TrkB receptor.

Dendrite structure and synaptic plasticity are altered in the hippocampus of cortactin knockout mice

Kristin Michaelsen-Preusse, Melissa O'Brien¹, Ulrike Herrmann¹, Klemens Rottner²,
Martin Korte¹

¹TU Braunschweig, Cellular Neurobiology, Spielmannstr. 7, 38106 Braunschweig, Germany

²University of Bonn, Actin Dynamics and Motility Unit, Karlrobert-Kreiten-Str. 13, 53115 Bonn, Germany

Actin dynamics in neurons are equally important for structural stability, allowing proper signal transduction, and for plastic changes of neuronal structure. This tremendous task is fulfilled with the help of an ever increasing number of factors discovered to tightly regulate actin polymerization and F-actin structure in space and time. Among these, cortactin may play an important role, as it is known to directly interact with and regulate actin filaments and the actin-related protein 2/3 complex (Arp2/3). Moreover, cortactin is the target of several important kinases (Src, PAK, ERK) and therefore a likely candidate to translate extracellular cues into the reorganization of the neuronal cytoskeleton, a key function underlying the ability of nerve cells to undergo functional and structural plasticity.

Cortactin is especially enriched in dendritic spines, tiny protoplasmatic protrusions that provide the major excitatory input onto pyramidal neurons in the neocortex and hippocampus. Interestingly, an activity-dependent redistribution of cortactin out of spines into the dendritic shaft has been reported in hippocampal neurons following activation of NMDA receptors or via BDNF-TrkB signaling events.

To elucidate the role of cortactin in synaptic plasticity and dendrite structure in the murine hippocampus, we took advantage of a recently generated cortactin knock out mouse (Schnoor et al. 2011). Dendrite structure, spine density and spine morphology were analyzed in great detail using biolistical transfection (Helios gene gun system) of a farnesylated form of eGFP (fGFP) in organotypic hippocampal slice cultures. In contrast to previous studies reporting a reduction in neurite complexity upon an RNAi-mediated loss of cortactin, morphological analysis of hippocampal neurons derived from cortactin KO mice revealed a significant increase in dendrite complexity, specifically in the basal dendrites of both CA1 and CA3 pyramidal neurons. Changes in spine density and morphology, however, were only subtle and primarily restricted to the apical dendrites.

In a second set of experiments, we investigated basal synaptic properties as well as synaptic plasticity in the form of long-term potentiation (LTP). Cortactin knock out animals were compared to WT littermate controls at 14 weeks of age. LTP was found to be impaired in acute hippocampal slice preparations of cortactin KO animals compared to littermate controls. Baseline synaptic transmission was slightly reduced at given stimulus intensities as well as at defined fiber volley amplitudes.

In summary, our data point to a crucial role for cortactin in mediating both neuronal structure and function. Future experiments will be aimed at investigating the mechanism of how cortactin might be involved in the induction and maintenance of LTP, and whether it might be in addition a modulator of structural plasticity at single dendritic spines. Finally, the learning behavior will be tested employing the Morris Water maze to further elucidate the role of cortactin in processes of structural synaptic plasticity and long-lasting memory formation.

Electrical activation of the locus coeruleus induces hippocampal LTD in the dentate gyrus

Niels Hansen, Denise Manahan-Vaughan¹

¹Ruhr University Bochum, Department of Neurophysiology, Universitätsstrasse 150, 44780 Bochum, Germany

The locus coeruleus (LC) fires rhythmically after novel stimuli and releases noradrenaline in the hippocampus. We hypothesized that the LC provide the saliency signal necessary for fostering of hippocampal encoding of relevant information through alterations in synaptic strength. Test pulse stimulation evoked basal synaptic transmission at perforant path (pp)- dentate gyrus (DG) synapses in freely behaving rats. Coupling of these test pulses with electrical high frequency stimulation of the LC (2 trains at 100Hz) induced long-term depression (LTD) at pp-DG synapses. Our results demonstrate that the LC is a pivotal player in the induction of hippocampal LTD in DG and in promoting the encoding of salient information. This LC-hippocampal interaction may indicate a means by which salient information is differentiated for subsequent synaptic processing in the hippocampus.

Nogo-A orchestrate actin dynamics within dendritic spine of mature hippocampal neurons

Yves Kellner, Martin E. Schwab², Martin Korte¹, Marta Zagrebelsky¹

¹TU Braunschweig, Zoological Institute, Div. Cellular Neurobiology, Braunschweig, Germany

²Brain Res. Inst., Univ. and ETH Zurich, Zurich, Switzerland

In the mature central nervous system (CNS) the fine tuning of the neuronal circuitry depends upon both functional and structural plasticity at synapses. Dendritic spines are small actin-rich protrusions that form the postsynaptic part of most excitatory synapses. They play crucial roles in synaptic function and exhibit a striking degree of structural plasticity. Indeed, changes in the number and morphology of dendritic spines have been correlated to long-term activity-dependent synaptic plasticity. While much has been described about molecules promoting plasticity, much less is known about the molecules and mechanisms regulating the balance between stability and plasticity of mature neuronal networks. The myelin-associated neurite growth inhibitor Nogo-A, is well known for its ability to inhibit axonal regeneration following an injury of the CNS, however its role in the intact brain is still largely unexplored. Interestingly, recent data provide evidence showing that Nogo -A restricts activity-dependent synaptic plasticity in the mature uninjured hippocampus (Delekate et al., 2011). Moreover, we could show a function of Nogo-A in stabilizing the dendritic architecture and spine morphology of mature neurons, thereby possibly contributing to maintaining the stability of the hippocampal circuitry (Zagrebelsky et al., 2010). There is reasonable evidence that dendritic spines as well as the changes in their morphology are determined by the alterations in the dynamics of the actin cytoskeleton. We address here whether Nogo-A modulates structural changes at spines by altering actin dynamics. To this aim we perform fluorescence recovery after photobleaching (FRAP) for actin-GFP at single spines upon the application of either a loss- (Nogo-A neutralizing antibodies) or a gain-of-function (Nogo-A-delta20 inhibitory peptide) approach for Nogo A. To calculate the fluorescence recovery curve of actin -GFP at single dendritic spines after photobleaching each two seconds images were taken up to two minutes. Our results show that the turnover-time of the actin treadmilling within single dendritic spines is significantly prolonged upon Nogo-A loss-of-function as well as gain-of-function (after 20/180min). Moreover, we observe under these conditions an increase in the stable filamentous (F -) actin pool, possibly leading to elongation/growth of new dendritic spines. Our data show that Nogo -A acutely (on a time scale of minutes) regulates the turnover of actin dynamics in single, mature spines.

Furthermore in ongoing experiments we address the signaling cascades mediating the effect of Nogo-A on actin dynamics. Specifically, the role of the Nogo Receptor as well as of the Rho/ROCK pathway is being analyzed in this context.

Supported by the DFG, (Az. ZA554/3-1)

MicroRNA expression in the barrel cortex after sensory stimulation

Ines Khadimallah, Nathalie Wenger¹, Rudolf Kraftsik¹, Romano Regazzi¹, Guylène Kirschmann², Egbert Welker¹

¹University of Lausanne, Department of Fundamental Neurosciences, Rue de Bugnon 9, 1005 Lausanne, Switzerland

²Department of Anesthesiology, University Hospital Center, Lausanne, Switzerland

In the adult mouse barrel cortex, continuous whisker stimulation induces structural and functional changes in the corresponding barrel. These modifications include the depression of neuronal responses and the insertion of new inhibitory synapses on spines (Knott et al., *Neuron*, 2002; Genoud et al., *PLoS Biol*, 2006; Quairiaux et al., *JNeurophysiol.* 2007). Although it's clear that spine remodeling is required for synaptic modification, the underlying molecular mechanisms remain unclear. Among the candidates, microRNAs could play a key role in cortical plasticity (Siegel et al., *Nat Cell Biol.* 2009). Using a chip-analysis we identified two microRNAs (miR-132 and miR-137) among the hundreds of significantly regulated genes. In the present study, we selected four microRNAs that are known to control the expression of mRNAs within the dendrites and that have been identified previously as being strongly implicated in synaptic plasticity (Edbauer et al., *Neuron.* 2010; Siegel et al., *Nat Cell Biol.* 2009; Olsen et al., *PLoS One*, 2009): miR-125b, miR-132, miR-137 and miR-138. To investigate the involvement of these small molecules in cortical plasticity in the adult mouse barrel cortex, we measured the expression level of these four microRNAs after stimulation of three whiskers (C1-3) using *in situ* hybridization with DIG 3' and 5' labeled LNA probes. We performed a quantitative microscopic analysis to compare the expression in stimulated and adjacent non-stimulated barrels for each microRNA. Six male C57BL/6 mice per microRNA were treated under the same conditions. To analyze microRNA-staining, we acquired 9-18 images in stimulated and non-stimulated barrels per animal. Using ImageJ software, all images were thresholded at a value corresponding to the mean intensity of the image \pm two standard deviations. The resulting spots were analyzed with an image segmentation algorithm to determine the microRNA-stained area fraction as an indicator of the amount of microRNA expressed. From the measurements a ratio was calculated per animal to quantify the difference between stimulated and non-stimulated barrels. The mean ratio obtained from different mice was compared with a t-test. Data set showed a significant increase, in stimulated barrels, of both miR-132 ($p=0.02$) and miR-137 ($p=0.03$) after 3 hours and 24 hours of stimulation, respectively. Ratio means of miR-125b (9h of stimulation) showed that stimulated barrels express a significant lower level as the adjacent, non-stimulated barrels ($p=0.002$). Regarding miR-138 staining (9h of stimulation), no difference between stimulated and adjacent non-stimulated barrels was detected. Contrary to the three other microRNAs that were expressed by all cortical cells, miR-138 is highly expressed in a subpopulation of neurons. In conclusion, using the model of the whisker-to-barrel pathway, our results suggest the involvement of microRNAs in sensory activity-dependent cortical plasticity in the adult mouse.

Electrophysiological characterization of the inhibitory MNTB-LSO connection upon prolonged high frequency stimulation: the effect of intermittent stimuli

Martin Fuhr, Eckhard Friauf¹

¹Technische Universität Kaiserslautern, Department of Biology, Animal Physiology Group, Erwin-Schrödinger-Strasse 13-566, 67663 Kaiserslautern, Germany

During ongoing activity, synaptic strength can undergo facilitation, depression, or a mixture of both. This short-term synaptic plasticity plays a key role in synaptic computation and has been extensively investigated for excitatory synapses. Much less is known about inhibitory synapses. In the mammalian auditory brainstem, the glycinergic projection from the medial nucleus of the trapezoid body (MNTB) to the lateral superior olive (LSO) is ideally suited to study short term plasticity at inhibitory synapses. We characterized the MNTB-LSO connection in acute brain slices of P10-12 wild-type mice. Focal electrical stimulation of MNTB fibers was combined with patch-clamp recordings of LSO neurons. In a first set of experiments, stimulus trains were applied at 1-800Hz and lasted up to 10 min at 25°C. To block excitatory inputs, D-AP5 and CNQX were added. Evoked inhibitory postsynaptic current peak amplitudes showed a frequency-dependent depression. Peak amplitudes became depressed by 30-40% already at 10 Hz within the first 50 pulses. At this frequency, the depression was followed by a steady-state period with amplitudes of about 60%. At frequencies >50 Hz, this phenomenon proceeded in an increasing depression and upcoming failures. To account for the possibility that continuous stimulation at a constant frequency is non-physiological, particularly at early developmental stages (Sonntag et. al., Journal of Neuroscience, 2009), we performed experiments at near physiological temperature (37°C) and under more natural stimulation patterns. For this purpose, we used the same pharmacology and an on/off stimulation protocol consisting of bursts (short stimulation trains) and gaps (periods of no stimulation). Stimulation frequencies ranged from 1-333 Hz and stimulation periods lasted 1 min, followed by a 1-min recovery phase. At each frequency, we used 4 on/off patterns, ranging from 200/200 ms to 200/50 ms (stimulation burst/gap duration). To analyze the performance of the inhibitory MNTB-LSO synapses, we investigated the amplitudes of single bursts at different time points of stimulation (Fig. 1A). Preliminary data showed that the first burst elicited a strong frequency-dependent depression. However, the response to last burst started with lower amplitudes and illustrated weaker depression or a steady state. At frequencies >100 Hz, we found higher peak amplitudes in the last burst in 200/200ms on/off stimulation, whereas the continuous (200/0ms) and 200/50ms on/off stimulation elicited an ongoing depression (Fig. 1B). We conclude from these preliminary data that the performance of LSO neurons is higher in stimulus trains where they obtain short gaps for recovery. Hence, the longer the gaps between the bursts, the higher is the performance of LSO neurons over time.

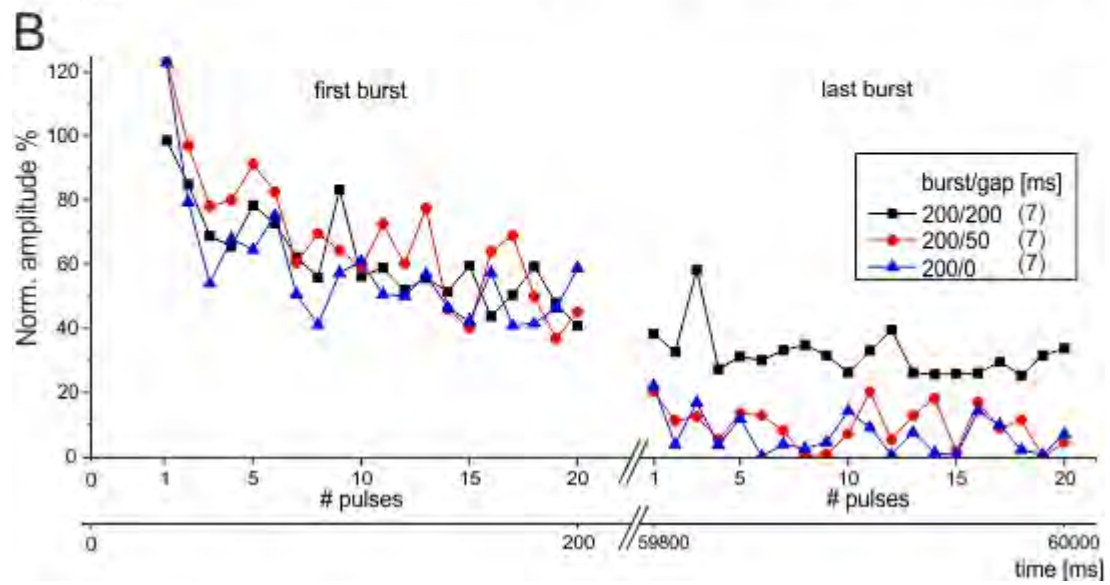
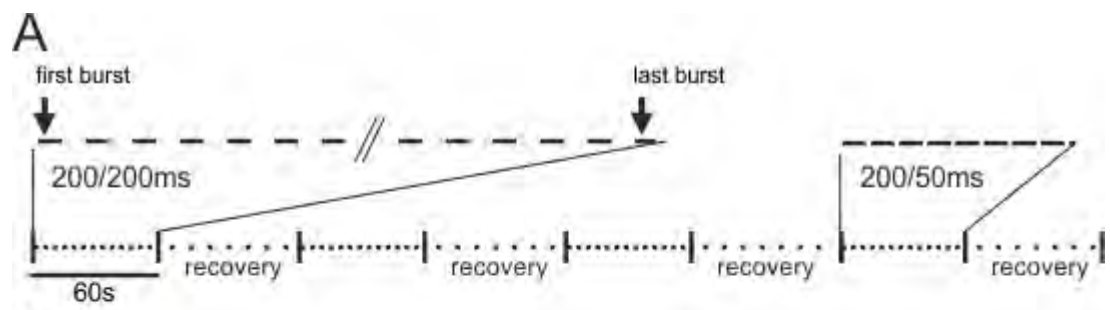

“Functional Role of Metabotropic Group I Glutamate Receptors in Synaptic Plasticity at Granule Cell – Basket Cell Synapses”

Thomas Hainmüller, Akos Kulik², Marlene Bartos¹

¹Institut für Physiologie I, Universität Freiburg, 79104 Germany. ²Institut für Physiologie II, Universität Freiburg, 79104 Germany

Synaptic plasticity has been proposed and subsequently demonstrated at glutamatergic synapses in networks of excitatory principal cells (Hebb, 1949). In contrast, plasticity in GABAergic inhibitory interneurons remained controversial for a long time (McBain et al., Trends Neurosci. 22, 1999). Only recently a number of studies demonstrated that plastic changes may take place at excitatory input synapses onto interneurons. Moreover, these studies revealed an unexpected variety in the forms of plasticity in these cells (Kullmann & Lamsa, Front. Synaptic Neurosci. 2, 2010).

Interneuron plasticity is assumed to be important for an enhanced recruitment of GABAergic cells, resulting in enhanced feedforward and feedback inhibition in the network. Interneurons are highly diverse and can be divided into several types based on the distribution of their output synapses, neurochemical profile and physiological properties. Among the different types, specifically parvalbumin-positive fast-spiking basket cells (PV/BCs) have been shown to be extremely important for the regulation of the neuronal network. They control for example the timing and frequency of action potential generation in their target cells by rapid and precisely timed perisomatic inhibition (Pouille & Scanziani, Science 293, 2001). PV/BCs receive recurrent excitatory input from local granule cells (GCs), which can undergo a Hebbian form of long term potentiation (LTP). This synaptic plasticity depends on the associative action potential generation in pre- and postsynaptic cells. Here, LTP requires a postsynaptic Ca^{2+} rise, activation of CP-AMPA receptors and protein kinase C (Sambandan et al., J. Neurosci. 30, 2010). Using *in vitro* whole-cell-patch-clamp recordings during extracellular stimulation of GC axons in combination with Ca^{2+} imaging, we show that two types of group I metabotropic glutamate receptors (mGluRs), namely mGluR 1 and mGluR 5, jointly participate in the induction of LTP at GC-PV/BC synapses by raising the intracellular Ca^{2+} level via release from internal stores and transient receptor potential (TRP) channels. Thereby they boost the fast and reliable recruitment of PV/BCs which is an important prerequisite for hippocampal gamma-oscillations underlying cognitive brain functions (Bartos et al., Nature Reviews 8, 2007).

Mossy fiber – CA3 and associational/commissural CA3 synapses reveal differences in the protein synthesis-dependency of persistent plasticity in vivo

Hardy Hagen, Denise Manahan-Vaughan¹

¹Ruhr-Universität Bochum, Abteilung für Neurophysiologie, Universitätsstraße 150, 44780 Bochum, Germany

Persistent plasticity, such as long-term potentiation (LTP) and long-term depression (LTD) are two mechanisms involved in the long-term storage of information in hippocampal synapses (Manahan-Vaughan and Braunewell, 1999; Braunewell and Manahan-Vaughan, 2001, Morris et al., 2003). In the hippocampal CA1 region, the late phases of LTP and LTD are protein-synthesis dependent (Stanton and Sarvey, 1984, Huang and Kandel, 1994, Manahan-Vaughan et al., 2000). In the dentate gyrus, late-LTP but not LTD requires protein synthesis (Otani et al., 1998, Nguyen et al., 1994, Naie and Manahan-Vaughan, 2005). The protein synthesis-dependency of persistent plasticity at CA3 synapses in vivo has not yet been characterized.

Male Wistar rats (7-8 weeks, Charles River, Germany) were anaesthetized (Pentobarbital 52 mg/kg) and underwent chronic implantation of hippocampal electrodes, as described previously (Hagen and Manahan-Vaughan, 2010) to enable monitoring of evoked potentials at mossy fiber (mf)- and associational/commissural (AC) - CA3 synapses. Long-term depression (LTD) was induced by low-frequency stimulation (LFS) at 1 Hz and with 900 pulses. Long-term potentiation (LTP) was elicited using 4 trains of 100 pulses at 100 Hz. The effects of the reversible translation inhibitors anisomycin (2-[methoxybenzyl]-3,4-pyrrolidinediol 3-acetate) and emetine, or the transcription inhibitors Actinomycin-D and DRB (5,6-dichloro-1-beta-D-ribofuranosylbenzamidazole) were assessed via intracerebral injection.

We have found that in control animals, low-frequency stimulation (LFS) evoked robust LTD (>24h), whereas high-frequency stimulation (HFS) elicited robust LTP (>24h). Application of translation inhibitors prevented early and late phases of LTP and LTD at mf-CA3 synapses, whereas transcription inhibitors inhibited late-LTP and late-LTD (>3h) only. In contrast, at AC-CA3 synapses, translation inhibitors prevented late-LTP and late-LTD whereas inhibition of protein transcription affected early-LTP and early-LTD.

These data suggest that mf-CA3 and AC-CA3 synapses display different properties regarding their dependency on protein synthesis which may reflect the roles these synapses play in the processing of short- and long term synaptic plasticity.

Acknowledgements: This work was supported by a Deutsche Forschungsgemeinschaft grant to DMV.

Pheromonal regulation of synaptic plasticity in the mushroom-body calyx during adult behavioral maturation in the honeybee

Thomas Sebastian Muenz, Claudia Groh¹, Alban Maisonnasse², Kornelia Grübel¹,
Yves Le Conte², Wolfgang Rössler¹

¹University of Würzburg, Biozentrum, Department of Behavioral Physiology and Sociobiology, Am Hubland, 97074 Würzburg, Germany

²Abeilles et Environment, Laboratoire Biologie et Protection de l'Abeille, INRA UMR 406, Site Agroparc, 84914 Avignon, France

In honeybee colonies the female worker caste expresses a pronounced polyethism with summer bees performing a rich behavioral repertoire ranging from various indoor duties (e.g. feeding, building = nurse bees) to foraging nectar, pollen and water outside the hive (= foragers). This transition from in-hive duties to foraging is accompanied by tremendous changes in the sensory environment that sensory systems as well as centers for higher order information processing have to cope with. Previous studies have shown that foraging and age are associated with volume changes in the mushroom bodies (MBs), brain structures known to be involved in multi modal sensory processing and learning and memory. In the present study we used age- and task-controlled bees within normal colonies to investigate structural plasticity of synaptic complexes (microglomeruli, MG) during adult maturation in visual input regions of the MB calyx. Pre- and postsynaptic compartments of these synaptic microcircuits were visualized using markers for synaptic proteins and cytoskeletal elements, which were analyzed by confocal laser scanning microscopy and quantified via 3D image processing. Examination of the density and numbers of MG revealed a general synaptic pruning in concert with an increased Kenyon-cell dendritic branching as the major mechanisms underlying the observed volume changes during the transition from nurse bees to foragers. However, our results also show that synaptic reorganization begins prior to the onset of foraging and may start as early as one week after adult eclosion. We hypothesize that this may correlate with the onset of the first orientation flights. To further confirm these findings we took advantage of the fact that division of labor in a honeybee colony is not purely age-dependent but further modulated by chemical communication signals enabling the colony to respond in a flexible manner to environmental changes by shifting the work force between indoor and outdoor duties. One of these chemical communication signals is the primer pheromone Ethyl oleate (EO), which is found at high concentrations only on foraging bees and has been shown to delay the onset age of foraging within the colony. We applied additional EO to triple cohort colonies to artificially delay the onset of foraging activity in focal bees and subsequently analyzed structural synaptic plasticity in the MB calyx. Effects of EO on colony behavior were not as robust as expected, and no direct correlation between EO treatment and synaptic maturation status was observed. However, analyses of the course of synaptic maturation revealed that already the status of synaptic maturation after the first week of adult life is a good predictor whether a control or EO treated group started earlier with foraging. We therefore conclude that the primer pheromone EO is strongly embedded in the concert of many other factors influencing the onset of foraging, but presumably has no direct influence on synaptic maturation.

Supported by Human Frontier Science Program (RGP0042/2007)

Long-term plasticity at the olfactory bulb mitral – granule cell synapse

Mahua Chatterjee, Fernando Pérez de los Cobos Pallarés¹, Veronica Egger¹

¹LMU Munich, Neurobiology, Department II, AG Egger, Großhaderner Str. 2, 82152 Planegg-Martinsried, Germany

In the mammalian olfactory bulb, axonless granule cells (GCs) mediate self- and lateral inhibitory interactions between mitral/tufted cells via reciprocal dendrodendritic synapses. Little is known on plasticity at this synapse. Mitral cell (MC) activity during odor sensation occurs in repetitive bursts that are synchronized to the respiration rhythm. We have set out to explore long-term plasticity at this synapse by using a theta-burst type stimulation protocol (TBS, five 40 Hz bursts at 4 Hz, repeated ten times at 0.1 Hz) that mimicks this type of natural MC activity to excite GCs via the MC input. We use whole-cell electrophysiological recordings from GCs in conjunction with glomerular stimulation of MCs in acute brain slices from juvenile rats (P12-P18).

The TBS protocol reliably induced long-term depression (LTD) of granule cell EPSPs in most cells tested (71 ± 21 % of control, $n = 12$ of 16 cells, $p < 0.005$), while postsynaptic spiking during TBS was no prerequisite for LTD induction.

Conversely, theta stimulation alone (87 ± 21 %, $n = 8$, $p = 0.11$ vs 100%) or a train of stimulations equal in number to the TBS protocol (40 Hz; 89 ± 11 %, $n = 6$, $p = 0.07$ vs 100 %) were not effective in inducing substantial plastic changes.

Since recently it was observed by several groups that rats can detect and discriminate odors within single sniffs, we have also applied a “single sniff” paradigm using just a single 40 Hz burst for ten times at 0.1 Hz. Subsequently, either LTD or LTP were observed (total experiments $n = 16$; LTD: 78 ± 10 % of control, $n = 9$; LTP 155 ± 55 %, $n = 7$). This bidirectional plasticity was independent of the occurrence of GC sodium spikes or the maximal depolarization during the induction. Larger EPSPs showed less plasticity than small EPSPs. The plasticity was “homoglomerular” and thus specific to the stimulated synapses, since it was not registered in neighboring glomerular control input pathways ($n = 6$).

In the presence of the NMDA receptor blocker APV, TBS no longer resulted in LTD (104 ± 17 % of control, $n = 6$), further underscoring the important role of the NMDA receptor at this synapse.

In summary, the MTC-GC synapse undergoes substantial plasticity following MTC activity modelled on in vivo olfactory input patterns, whereas other types of stimulation are less effective. Thus aspects of olfactory memory may be encoded at this synapse.

Ependymin: Expression studies of a Microheterogeneous Sialoprotein in the Nervous System

Donato Penninella, Rupert Schmidt¹

¹Justus-Liebig-University Gießen, Biotechnology Centre, Leihgesterner Weg 217, 35392 Gießen, Germany

Ependymins are secretory cell adhesion molecules and the predominant constituents of the cerebrospinal fluid of many teleost fish. They are involved in memory consolidation and neural regeneration processes. Ependymin expression is rapidly induced in meningeal fibroblasts after learning events, such as active shock-avoidance conditioning followed by the protein's secretion into the extracellular and cerebrospinal fluids.

2D-PAGE analyses of goldfish brain homogenate and extracellular fluid now revealed that ependymins are microheterogeneous proteins appearing in different isoforms. The major ependymins arise in two double bands with apparent molecular weights of 28.5 and 30.5 kD ("γ"; mono-N-glycosylated), and 35.5 and 37 kD ("β"; bi-N-glycosylated), respectively. The γ-ependymins comprise isoforms with at least nine different isoelectric points (pI), whereas β-ependymins comprise isoforms with at least eight different pI. To investigate these microheterogeneous isoforms, single spots from 2D-gels, which represent ependymins with accurately defined pI, were eluted and re-separated. This second separation on a 2D-gel resulted again in the appearance of at least eight isoforms with different pI. Furthermore, it was shown that de-glycosylated ependymins comprise different microheterogeneous isoforms, demonstrating these are neither caused by N-linked glycans nor by differences in the amino acid sequences. We assume that the microheterogeneous isoforms may be caused by formation of stable conformational isomers.

Treatment with neuraminidase revealed that ependymins also exist in different highly sialylated forms. Sialylation could play an important role for the regulation of cell adhesion by reducing ependymin's binding affinity.

To further elucidate the functionality of ependymins it is important to study the expression mechanism of these proteins. There is evidence that the expression is regulated by existing ependymin concentrations (negative feedback) and possibly also by stress hormones. Therefore, goldfish meningeal fibroblasts were cultivated in an attempt to modulate ependymin expression by addition of several agents to the cell culture medium. First results show that ependymins are highly expressed in meningeal fibroblasts *in vitro* and are also secreted into the cell culture medium.

Enhancement of cholinergic output in *C. elegans* by the *Beggiatoa sp.* photo-activatable adenylyl cyclase.

Wagner Steuer Costa, Jana Fiona Liewald^{1,2}, Peter Hegemann³, Alexander Gottschalk^{1,2}

¹ Buchmann Institute for Molecular Life Sciences, Goethe University, Frankfurt, Germany

² Institute of Biochemistry, Goethe University, Frankfurt, Germany

³ Humboldt University, Berlin, Germany

C. elegans is a perfect model organism for optogenetic approaches to neuroscience research. The majority of optogenetic studies are based on microbial rhodopsins and their derivatives. Examples are Channelrhodopsin-2 and Halorhodopsin. However broadly applied, these proteins generally do not activate or inhibit neurons in a natural manner. The whole cell is strongly de- or hyperpolarized during their photo-activation, which overrides any intrinsic activity of the neuronal circuit where the targeted cell is situated in.

One further optogenetic approach pursued by our group is the usage of photo-activatable nucleotide cyclases instead of the aforementioned proteins. This class of proteins allows increasing the amount of cyclic nucleotides, which are major second messengers in different cell types. Our previous work with the *Euglena gracilis* photo-activatable adenylyl cyclase alpha subunit (EuPACa) [1] showed that photo-activation in cholinergic motor neurons enhanced their output and altered behavior [2]. This effect is probably due promoting synaptic vesicle priming via UNC-13. Although swimming cycles in liquid and crawling velocity in solid substrates were higher during EuPACa photo-activation, the high dark activity intrinsic to EuPACa somewhat limits its applicability as an optogenetic tool, as cells showed adaptation to chronically increased cAMP levels.

Here we characterized *Beggiatoa sp.* photo-activatable adenylyl cyclase (bPAC) [3] in *C. elegans* neurons (see figure 1A for expression in cholinergic motor neurons). As expected, bPAC photo-activation had similar phenotypes in cholinergic motor neurons as EuPACa, albeit without any obvious dark activity. We also observed an increase in the body bend angles during photo-activation of bPAC (see figure 1B). This phenotype is not associated to abnormal body contraction as it would be expected by photo-activation of Channelrhodopsin in the same neurons. The high light sensitivity of bPAC enables prolonged activation without the need for intense blue light, which might be harmful for biological systems. Further, bPAC is functional as a dimer and thus smaller than other photo-activatable adenylyl cyclase (see figure 1C). We tested the efficiency of bPAC also in a phosphodiesterase overexpression background. We could, to some extent, rescue the effects of chronic cAMP depletion. Furthermore, our first results with the use of bPAC for characterization of PKA phosphorylation targets and the internal modulation of neuronal output will be shown at the meeting.

Figure 1) A: Expression pattern of bPAC::YFP in cholinergic neurons of *C. elegans* (GFP channel). B: Photo-activation of bPAC leads to increase in body angles without affecting worms' motility. C: Model of the bPAC dimer with the blue light using FAD sensor domain (BLUF) and the adenylyl cyclase domain.

References:

- 1 - Schröder-Lang et al. (2007) *Nature Methods* 4: 39-42
- 2 - Weissenberger et al. (2011) *Journal of Neurochemistry* 116: 616-625
- 3 - Stierl et al. (2010) *The Journal of biological chemistry*

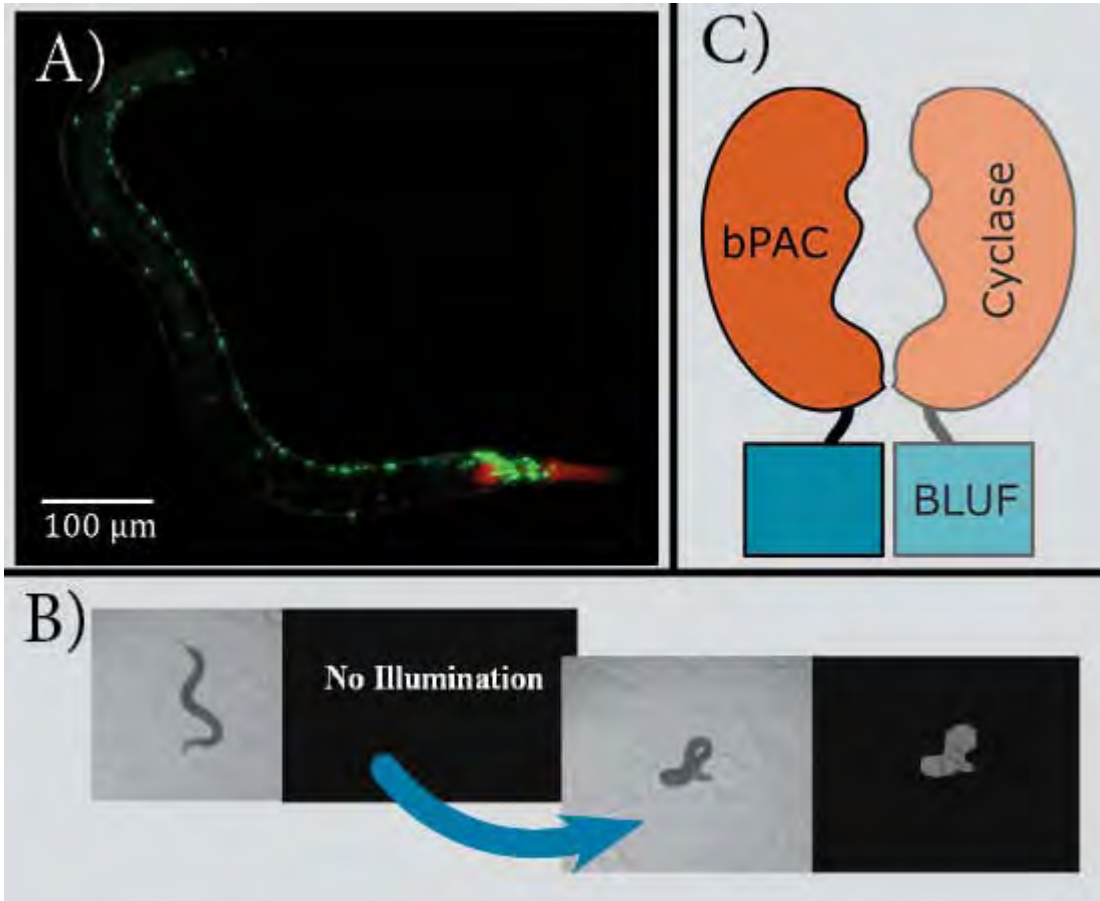

Dissecting the mechanisms of long-term depression in visual cortex.

Plinio das Neves Favaro, Oliver M. Schlüter¹

¹European Neuroscience Institute Göttingen.

²GGNB doctoral program: Molecular Physiology of the Brain.

INTRODUCTION: NMDA receptor-dependent Long Term Depression (LTD) has been proposed to be the cellular mechanism underlying ocular dominance plasticity in visual cortex after monocular deprivation. In the vertical connections between layer 4 and layers 2/3 of rodent visual cortex, LTD is suggested to be presynaptic. It does not involve internalization of postsynaptic AMPA receptors, but is blocked by NMDA or CB1 receptor antagonists (Crozier et al, 2007).

OBJECTIVE: The aim of the present work is to dissect the molecular mechanisms of LTD in visual cortex, manipulating NMDA and CB1 receptors.

METHODS: Extracellular stimulation was delivered in cortical layer 4 and evoked EPSCs were recorded from layer 2/3 pyramidal neurons using voltage-clamp recordings from acute slices. LTD was induced by pairing presynaptic stimulation with a postsynaptic-step depolarization from -65 to -45 mV. LTD was quantified 20 -30 minutes after induction. NMDA receptors and cannabinoid 1 receptors (CB1r) were blocked by bath application of APV and AM251. Statistical analysis was student t-test. Significance was $p=0.05$.

RESULTS: LTD was characterized by a reduction in EPSC amplitude ($66.37 \% \pm 7.2$) accompanied by an increase in the EPSC coefficient of variation (CV). [CV before induction/CV after induction (d) = 0.53 ± 0.14], suggesting a presynaptic locus of expression. Both APV and AM251 appear to block LTD ($91.00\% \pm 8.4$ and $93.60\% \pm 7.5$, respectively) and prevent changes in CV ($d = 1.01 \pm 0.27$ and 1.31 ± 0.46 , respectively).

CONCLUSION: Our data confirm that LTD relies on the activity of both NMDAr and CB1r and supports the notion that it might be presynaptic, characterized by a reduction in release probability. Nevertheless, increases in CV can also be interpreted as postsynaptic silencing after LTD induction. Additional experiments are being performed in order to dissect the specific synaptic locus of LTD expression in visual cortex.

Differential pre- and postsynaptic contribution to t-LTP expression in hippocampal CA1 region depends on induction paradigm

Martin Wilhelm Erich Franck, Volkmar Leßmann^{1,2}, Elke Edelmann¹

¹Otto-von-Guericke University Magdeburg, Institute of Physiology, Leipziger Str. 44, 39120 Magdeburg, Germany

²Center of Behavioral Brain Sciences (CBBS)
39120 Magdeburg, Germany

It is widely accepted that long-term potentiation (LTP) and long-term depression (LTD) are cellular substrates of learning and memory. The common induction paradigms for LTP are theta-burst- or high-frequency-stimulations, pairing protocols, as well as spike timing-dependent plasticity (STDP). LTP mechanisms are characterized best for hippocampal Schaffer Collateral (SC) -CA1 synapses. The expression of early LTP at these synapses has been shown to depend largely on postsynaptic mechanisms, while later stages of LTP might include also presynaptic processes. BDNF signaling is known to contribute to pre- and postsynaptic mechanisms of plasticity in CA1 (Gottmann et al., 2009).

In this study, we want to elucidate the differential recruitment of LTP-expression mechanisms, using different forms of a low frequency induction paradigm, called STDP, combining presynaptically induced EPSPs with precisely timed postsynaptic APs. Therefore we performed whole-cell patch-clamp measurements of CA1 pyramidal-cells in acute hippocampal slices of male C57Bl/6J mice (P25-35) activating either one or two independent SC-pathways. By pairing one EPSP with either one, two or four postsynaptic APs, we established three different STDP-protocols, of which the 1EPSP/4AP combination was BDNF-dependent while the first two protocols were BDNF-independent (1EPSP/1AP, 1EPSP/2AP). With short positive spike timings ($\Delta t = +10\text{ms}$) all three protocols lead to a reliable timing-dependent (t-) LTP (1EPSP/1AP: 1.42 ± 0.1 ; 1EPSP/2AP: 1.60 ± 0.2 ; 1EPSP/4AP: 1.43 ± 0.1). Analysis of changes in paired-pulse ratio (PPR) and coefficient of variance (CV), both indicators of the locus of LTP-expression, pointed to a mainly postsynaptic locus of expression for 1EPSP/4AP and a presynaptic locus of expression for the other two protocols.

To investigate the mechanism of LTP expression of our different protocols, we chose to test for postsynaptic incorporation of AMPA-receptors (AMPA) as a candidate mechanism. To achieve this, we included the inhibitory peptide Pep1-TGL into the patch-pipette. Pep1-TGL is a highly specific blocker of AMPAR-insertion. It mimics the end of the C-terminus of GluR1, thereby abolishing interaction with proteins essential for membrane-insertion of GluR1. A theta-burst pairing known to be sensitive to the peptide (Lin et al., J Neurosci. 2010) was established to show the peptide's functionality in our recording conditions. We observed an impairment of LTP using Pep1-TGL with the theta-burst pairing (control: 1.40 ± 0.1 ; Pep1-TGL: 1.09 ± 0.3). However, the 1EPSP/1AP protocol with Pep1-TGL was not different from control (control: 1.42 ± 0.1 ; Pep1-TGL: 1.41 ± 0.1). We are currently analyzing the LTP-expression mechanisms of the 1EPSP/2AP and our BDNF-dependent 1EPSP/4AP protocol by inhibition of AMPAR incorporation with Pep1-TGL.

Taken together, our data show that BDNF is recruited in a stimulus dependent fashion in hippocampal LTP induced with physiologically relevant protocols. Furthermore first data indicate that postsynaptic activation patterns not only determine BDNF recruitment, but also influence the locus of LTP expression.

This work is supported by CBBS/EFRE.

Metaplasticity by ryanodine receptor activation promotes the recovery of synaptic impairments in the APP/PS1 mouse model of Alzheimer's disease

Qin Li, Martin Korte¹, Sreedharan Sajikumar²

¹Zoological Institute, Div. Cellular Neurobiology, TU Braunschweig, Spielmannstr. 7, 38106 Braunschweig, Germany

²Department of Physiology, Yong Loo Lin School of Medicine, National University of Singapore, 117597, Singapore

Alzheimer's disease (AD) is a devastating neurodegenerative disorder characterized with progressive learning and memory loss. Multiple lines of evidence show synaptic plasticity deficits in the hippocampus as is one of the first events in the progression of AD. Long-term potentiation (LTP) is the most studied form of synaptic plasticity that underlies most likely many processes of learning and memory. Metaplasticity is the regulation of synaptic plasticity due to the history of synaptic activity at a specific neuron or in a network of neurons which has been demonstrated to contribute to the neurological recovery of function. We have shown earlier that metaplasticity by prior activation of ryanodine receptors (RyR) facilitates LTP by de novo protein synthesis (Li et al., 2012). In the present study, our main aim is to investigate whether synaptic impairments in the APP/PS1 mouse model of AD could be prevented by priming activation of RyR. Not only the late phase, protein-synthesis dependent form of LTP (L-LTP) was impaired in the CA1 region of hippocampal slices prepared from APP/PS1 mice (3-4-month old). But in addition associative heterosynaptic interaction between two sets of synapses were also impaired (STC). In contrast, L-LTP impairment was rescued by prior application of the ryanodine receptor agonist ryanodine (RYA; 10 μ M). In addition, the rescued L-LTP could take part in the STC. Protein synthesis inhibitor anisomycin and protein kinase ζ (PKM ζ) inhibitor myr-ZIP during RYA priming blocked the rescued L-LTP and it also prevented processes like STC which indicates that metaplasticity by RyR activation triggers protein synthesis of PKM ζ to prevent the synaptic impairments in APP/PS1 mice. These findings indicate that metaplasticity mediated by RyR activation can be used as a compensatory mechanism for preventing synaptic impairments in neuronal networks of AD. (Q.L.is funded by a DAAD stipend, S.S. was funded by the Humboldt Foundation)

Effects of a spatial learning task on the mammalian endymin related protein (MERP).

David Hinchliffe, Rupert Schmidt¹

¹Justus-Liebig Universität Gießen, Zentrale Biotechnische Betriebseinheit, Leihgesterner Weg 217, 35392 Gießen, Germany

Ependymins are glycoproteins synthesised in leptomeningeal fibroblasts and named according to the tissue they first could be found in, the goldfish ependymal zone (Benowitz and Shashoua, 1977). They are known to be involved in a variety of cellular functions related to neuronal regeneration and long-term memory formation. During the cloning of mammalian genomes, primate and murine genes coding for the mammalian endymin-related proteins (MERPs) have been found exhibiting homology to the piscine endymin. Northern blotting revealed the MERPs in various tissues, in particular in neoplastic cells of the intestine and in several brain regions (Apostolopoulos et al. 2001). Four cystein residues are highly conserved throughout the MERP family. Also potential N-linked glycosylation sites can be found. In teleosts bound oligosaccharides allow calcium to bind in turn (Schmidt and Makiola, 1991). Typical of the endymin structure is the L2/HNK-1 epitope, a feature of many neural cell adhesions molecules. The two murine MERPs (mu-MERPs), we are analysing here, show an identity of 99% and 83% (mu-MERP1 and mu-MERP2, respectively) compared to the protein sequence of human MERP1 as derived from the theoretical translation of the open reading frame.

The analysis of these proteins comprised the localisation of the mRNA synthesis site by *in-situ* hybridisations and the distribution of the actual protein with immunohistochemical staining, both performed on brain tissue of C57/Bl6J mice. Immunohistochemical stainings were done with a cross-reactive antibody against endymin, an antibody against MERP, anti-EPDR-1, and with an anti-GFAP antibody. The *in-situ* hybridisations were conducted by probes labelled with [³⁵S]-a-dATP.

Because of the structural relation to the teleosts' endymin, a functional similarity is not unlikely. Therefore we applied a spatial learning task (Morris-Water-Maze) and compared the quantity of MERP-mRNA synthesis by RT-PCR in dependence of the time elapsed after learning.

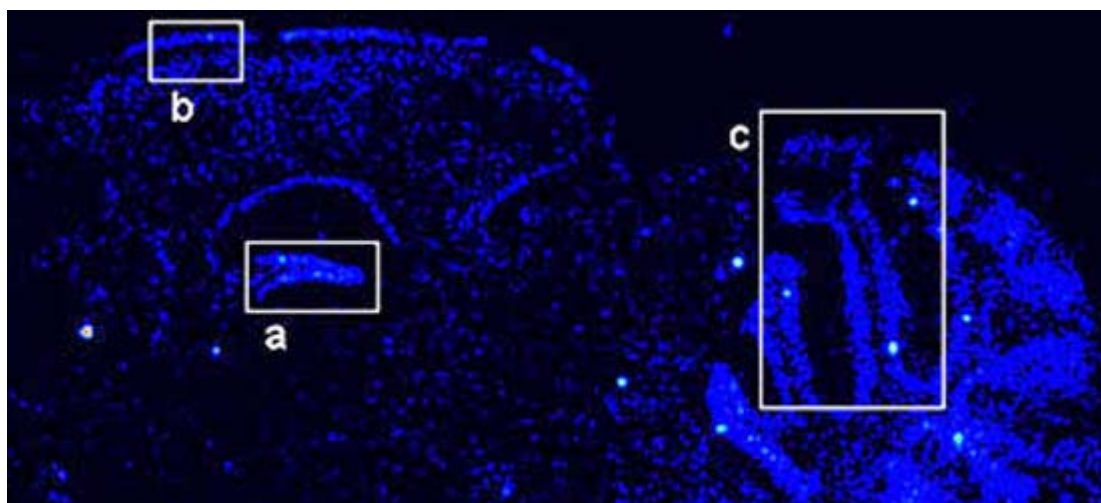

Dynamics of the synaptic fucosyl proteome

Nicole Höche, Karin Richter³, Thilo Kähne⁴, Wolfgang Tischmeyer¹, Karl-Heinz Smalla¹, Daniela C. Dieterich^{2,5}

¹Special Lab Molecular Biology Techniques, Leibniz Institute for Neurobiology, Magdeburg, Germany

²Institute for Pharmacology and Toxicology, Otto-von-Guericke University, Magdeburg, Germany

³Institute for Biochemistry and Cell Biology, Otto-von-Guericke University, Magdeburg, Germany

⁴Institute for Experimental Medicine, Otto-von-Guericke University, Magdeburg, Germany

⁵Emmy Noether Research Group Neuralomics, Leibniz Institute for Neurobiology, Magdeburg, Germany

Changes of synaptic efficacy are a fundamental aspect of neuronal plasticity. An important prerequisite for these changes are modulations on the proteome level, i.e. on the level of protein synthesis, protein degradation and posttranslational modifications. The covalent attachment of L-fucose to terminal positions of carbohydrate chains has been shown previously to be of particular importance as fucosylated carbohydrates in the brain have been implicated in molecular mechanisms underlying synaptic plasticity. This includes forms of developmental plasticity, learning and memory formation or hippocampal long-term potentiation (LTP), which are accompanied by a transient, increased fucosylation of glycoproteins. Most notably, inhibition of L-fucose incorporation does not interfere with LTP induction or memory acquisition, but prevents specifically the maintenance of LTP or long-term memory. However, the mechanisms underlying the functional implications of protein fucosylation for phenomena of long-term synaptic plasticity as well as the identity of those differentially fucosylated synaptic proteins are largely unknown at present. Therefore, the identification of fucosylated synaptic proteins and the modes of their biosynthesis and modification, and the determination of their subcellular localization are of invaluable importance for a better understanding of these aforementioned processes. In the present study, we use the fucose-specific lectin from *Aleuria aurantia* (AAL) to investigate the distribution of fucose-containing carbohydrates in rat brain. We find strong AAL staining of membrane structures especially in synaptic neuropil regions. To identify fucosylated synaptic proteins, extracts from synaptic junctions were analysed either in an unbiased approach using AAL affinity chromatography or in an approach using immunoprecipitations and AAL blotting. For this approach we focused on proteins previously implicated in neuroplasticity, i.e. neurotransmitter receptors, cell adhesion molecules, extracellular matrix proteins, voltage-gated potassium and calcium channels, growth factor receptors and ligand-gated ion channels. In addition, we performed an alternative strategy for tagging biomolecules using an azide-conjugated L-fucose derivative to specifically label and identify de novo fucosylated proteins in primary cortical cultures after NMDA-receptor mediated changes. As a result of this combined approach we identified a diverse range of already known as well as so far unknown fucosylated proteins, which have been implicated in processes of neuroplasticity such as neuroplastin, Thy 1.1, Caspr2 and Kv1.2. Furthermore this approach enabled us to track changes in protein fucosylation for several of the identified proteins in dependence on synaptic activity in primary cultures of cortical neurons. In summary, our combination of AAL-based and metabolic labeling approaches enabled a proteome-wide monitoring of fucosylation dynamics.

Nogo-A signaling plays a major role in modulating dendritic spine dynamics in CA3 hippocampal neurons

Marta Zagrebelsky, Martin E. Schwab², Martin Korte¹

¹ Cellular Neurobiology, TU Braunschweig, Braunschweig, Germany; ²Brain research Institute, ETH and University of Zurich, Zurich, Switzerland

In the mature central nervous system (CNS) a tightly regulated balance between plasticity and stability of the neuronal network allows the acquisition, storage and clearance of memories in a dynamic and highly controlled manner. Dendritic spines are particularly dynamic structures and their rapid formation, elimination and shape-changing has been shown to contribute to long-lasting synaptic plasticity. While much has been described about molecules promoting plasticity, very little is known regarding molecules and mechanisms maintaining the stability of the mature neuronal circuitry. The myelin associated neurite growth inhibitor, NogoA has become a major target for therapeutic intervention to facilitate axonal regeneration after CNS lesion. Most interestingly, a series of recent studies indicate that in the intact CNS NogoA signalling is involved in negatively regulating activity-dependent synaptic plasticity as well as in stabilizing the dendritic architecture of mature hippocampal pyramidal neurons. These observations suggest that a continuum of plasticity might be regulated by Nogo-A regardless of the initial stimulus (injury, experience, activity) implicating a general role of Nogo-A in maintaining the stability of mature neuronal networks in the mammalian CNS.

The current goal of our research is to explore whether and how NogoA might modulate dendritic spine dynamics in the mature, uninjured hippocampus. To this aim, we use time-lapse confocal microscopy to analyze the dynamics of dendritic spines by repetitively imaging every 20 minutes up to 6 hours second order apical dendrites of eGFP expressing mature hippocampal neurons upon application of a loss-of-function approach for NogoA (NogoA neutralizing antibodies). Interestingly, during the acute neutralization of NogoA we observe a progressive increase in dendritic spine number becoming significantly different from the controls 2 hours after the beginning of the treatment. Moreover, while in control cells dendritic spines length and mobility remain stable, upon NogoA neutralization these parameters significantly increase over time. Moreover, neutralizing the function of the Nogo receptor (NgR1) and blocking its downstream signalling inhibiting the Rho-associated protein kinase (ROCK) results on comparable changes at the level of dendritic spines.

Taken together our results so far point to a critical role of NogoA signalling in the hippocampus in acutely modulating dendritic spine dynamics on a fast time scale comparable to its activity in regulating activity-dependent changes in synaptic strength. Finally, we could show an increased activation of cofilin upon NogoA neutralization pointing to a possible effect of NogoA in modulating actin dynamics.

Founded by the DFG (ZA 554/3-1)

Norepinephrine Gates Hippocampal Std-Ltp By Potassium Channel Inactivation

Yanling Liu, Oliver M Schlueter¹

¹European Neuroscience Institute, molecular neurobiology, Grisebachstr. 5, 37077 Goettingen, Germany

1

Activity-dependent changes in synaptic weights are considered as the neuronal correlates for learning and memory. Adrenergic neuromodulators play a central role in enhancement of memory during emotional arousal. Norepinephrine (NE) lowers the threshold for inducing long-term synaptic potentiation. We show that NE gates spike-timing-dependent (STD) long-term potentiation (LTP) through β_2 adrenoceptor activation in hippocampal CA1 pyramidal neurons. Furthermore, NE inactivates a potassium channel current through β_2 adrenoceptor activation. Both, the STD-LTP and potassium channel inactivation are dependent on signaling scaffolds of the family of membrane-associated guanylate kinases (MAGUK). Our results are consistent with a role of the MAGUKs in gating STD-LTP by linking NE signaling through β_2 adrenoceptors to potassium channel inactivation. Furthermore they provide a mechanism how a specific set of synapses can be gated to be susceptible for long-term synaptic plasticity dependent on the behavioral/emotional state of an animal.

Alteration of inhibitory feedback mechanisms in the cochlea and dorsal root ganglion by KCC2 and NKCC1 after injury. A model for neuropathic pain and tinnitus?

Dario Campanelli, Annalisa Zuccotti¹, Wibke Singer¹, Lukas Rüttiger¹, Jeremy Tsung-Chieh Chen², Jing Hu², Marlies Knipper¹

¹HNO Klinik, molecular physiology of hearing, AG Knipper, Elfriede-Aulhorn-Strasse 5, 72076 Tübingen, Germany.

²CIN, Center for Integrative Neuroscience, Otfried-Müller-Str. 25, 72076, Tübingen, Germany.

The symptoms and signs of phantom sensations like tinnitus and neuropathic pain have many similarities (Moller AR., 2007). Similar hypothesis have been presented regarding how the symptoms are generated. The changes in the auditory system that cause tinnitus and the changes in the somatosensory system that cause neuropathic pain may be initiated from the periphery, i.e. the inner ear or the auditory nerve for tinnitus and peripheral nerve endings for neuropathic pain (Moller AR., 2007)

There is considerable evidence that expression of neuronal plasticity plays a central role in the development of the abnormalities that cause tinnitus and neuropathic pain. Changes in neuronal plasticity can affect the balance between excitation and inhibition, promote hyperactivity, and cause re-organization of specific parts of the nervous system e.g. redirection of information to parts of the nervous system normally not involved in processing information (Moller AR., 2007).

Since much more is known about the generation of neuropathic pain than about tinnitus, it is valuable to take advantage of the knowledge about neuropathic pain in efforts to understand the pathophysiology of tinnitus.

It is known that the chloride transporters NKCC1 (Sodium-Potassium-Chloride Co-transporter 1) and KCC2 (Potassium-Chloride Co-transporter 2) play a pivotal role in the generation of neuropathic pain (Price et al., 2009; Coull et al., 2005). Although most of the studies are focused on the central nervous system (Blaesse et al., 2009), there are some experimental evidences of an altered expression of NKCC1 and KCC2 after nerve injury, in the dorsal root ganglia (DRG) (Kanaka et al., 2001; Funk et al., 2008).

The aim of this study is to investigate if expression of NKCC1, KCC2 is altered following tinnitus-inducing trauma in the cochlea and neuropathic pain-inducing injury in DRGs.

This work was supported by the Deutsche Forschungsgemeinschaft (EXC 307).

Analysis of conditional APP/APLP2 double knock-out mice reveals a strong hippocampal CA3-CA1 LTP defect

Ulrike Herrmann, Meike Hick², Ulrike Müller², Martin Korte¹

¹TU-Braunschweig, Zoological Institute, Department Cellular Neurobiology, Germany ² University of Heidelberg, Institute for Pharmacy and Molecular Biotechnology, Department Functional Genomic, Germany

Learning and memory processes are based on functional and structural changes at synapses which can be studied by high frequency-stimulation induced long-term potentiation (LTP) at hippocampal Schaffer collateral synapses. The Amyloid Precursor Protein (APP) is well known to be involved in the pathophysiology of Alzheimer's disease. However, the physiological function of APP and its homologues APLP1/2 is largely undetermined. Using different mutants we study the functions of APP, APLP1 and APLP2 in synaptic transmission and plasticity of the rodent hippocampus. Postnatal lethality of APP/APLP2 double knock-out animals is circumvented by generating mice with conditional APP alleles on an APLP2 deficient background (APP^{flox}APLP2^{ko}, cDKO). In order to elucidate the role of both proteins in the adult CNS these mice were crossed to a tamoxifen inducible CaMKIIa-CreERT2 mouse line expressing the Cre recombinase in excitatory forebrain neurons. As a first approach we investigated the effect of postnatal knock-out of APP in adult animals. Therefore the conditional knock-out in CaMKIIa-CreERT2-cDKO animals was induced by one (2 months) or two injections of tamoxifen (P5; 2 months). This results in a strong reduction of APP in the hippocampus and the neocortex of adult (4-5 months) as well as aged (14-15 months) mice confirmed by in situ hybridization and immunohistochemistry. Analysis of hippocampal synaptic plasticity revealed a robust LTP induction and maintenance in the CaMKIIa-CreERT2-cDKO animals as well as in the control group. Surprisingly, only subtle defects were found in LTP and basal synaptic transmission in adult as well as in aged CaMKIIa-CreERT2-cDKO mice. But we observed a significant reduction in protein-synthesis-dependent long-lasting LTP (L-LTP) in these cDKO mice. These findings brought us to the second approach where we inactivated APP already during prenatal development by crossing APP^{flox}/APLP2^{ko} mice to NexCre^{+/T} mice. In these NexCre-cDKO mice the NexCre promoter is already active from E11.5 onwards leading to the expression of a constitutive form of Cre recombinase. In situ hybridization and immunohistochemistry confirmed a somewhat stronger APP reduction in excitatory pyramidal neurons in the hippocampus and the neocortex compared to CaMKIIa-CreERT2-cDKO animals. This led to a strong synaptic phenotype with pronounced deficits in the induction and maintenance of hippocampal CA3-CA1 LTP as well as a presynaptic defect in adult NexCre-cDKO mice (2 months). It will now be important to distinguish acute functions of APP/APLP2 during processes of synaptic plasticity in the mature nervous systems versus developmental functions during synaptogenesis. (supported by the DFG, FOR1332)

Synaptopodin regulates denervation-induced homeostatic synaptic plasticity of dentate granule cells in mouse entorhino-hippocampal slice cultures.

Andreas Vlachos, Benno Ikenberg¹, Maximilian Lenz¹, Kurt Reifenberg², Carlos Bas Orth¹, Thomas Deller¹

¹Institute of Clinical Neuroanatomy, Goethe-University, 60590 Frankfurt am Main, Germany

²Central Laboratory Animal Facility, Johannes Gutenberg-University, 55131 Mainz, Germany

The role of Synaptopodin (SP) in homeostatic synaptic plasticity of mouse dentate granule cells was studied in an organotypic environment. In entorhino-hippocampal slice cultures prepared from SP-deficient mice, which lack the spine apparatus organelle (SA), a compensatory increase in excitatory synaptic strength was not observed following partial deafferentation (at 3 - 4 d post lesion) or prolonged blockade of sodium channels with tetrodotoxin (2 - 3 d). By crossing SP-deficient mice with a newly generated transgenic mouse strain that expresses GFP-tagged SP under the control of the Thy1.2 promoter, the ability of dentate granule cells to form the SA and to homeostatically strengthen excitatory synapses was rescued. Using immunohistochemistry, fluorescence recovery after photobleaching and electron microscopy, we provide experimental evidence that the compensatory increase in excitatory synaptic strength is accompanied by changes in SP-cluster properties, i.e., changes in size and stability, and an increase in the number of dense plates forming SAs. These results provide experimental evidence that SP and the SA are important components of the molecular machinery, which homeostatically adjusts excitatory synaptic strength to perturbations of synaptic activity. (Supported by DFG).

mGluRs contribute to somatic $[Ca^{2+}]_i$ rises elicited in cerebellar molecular layer interneurons by parallel fiber stimulation in vivo

Jin Bao, Guadalupe Astorga¹, Abdelali Jalil¹, Jonathan Bradley¹, Isabel Llano¹

¹CNRS and Université Paris Descartes, Laboratoire de Physiologie Cerebrale, 45 Rue des Saints Peres, 75006 Paris, France

Activation of mGluRs on cerebellar molecular layer interneurons (MLIs) plays important roles in synaptic plasticity and generation of oscillatory responses. Here we demonstrate that group I mGluRs on MLIs are activated in vivo by high frequency (>50Hz) parallel fiber (PF, the glutamatergic input of MLIs) stimulation. Even a short burst (200 ms) of PF stimuli can activate mGluRs with variable efficacy. We also found that prolonged stimulation increases the peak amplitude of the somatic $[Ca^{2+}]_i$ rise linked to activation of mGluRs. The results suggest that stimulation of parallel fibers by sensory inputs should engage mGluR signaling in MLIs.

Repetitive magnetic stimulation induces coordinated functional and structural changes of excitatory postsynapses in mouse entorhino-hippocampal slice cultures

Maximilian Lenz, Johannes Roskopp^{1,2}, Ulf Ziemann^{2,3}, Thomas Deller¹, Florian Müller-Dahlhaus^{1,2}, Andreas Vlachos¹

¹Institute of Clinical Neuroanatomy, Goethe-University, 60590 Frankfurt am Main, Germany

²Department of Neurology, Goethe-University, 60590 Frankfurt am Main, Germany

³Department of Neurology and Stroke, Eberhard-Karls-University, 72076 Tübingen, Germany

Repetitive transcranial magnetic stimulation (rTMS) is a non-invasive brain stimulation technique, which can change cortical excitability of human subjects for hours beyond the stimulation period. It thus has a potential as a therapeutic tool in neurological disorders associated with altered cortical excitability. However, the effects of rTMS on neural plasticity remain not well understood at the cellular and molecular level. To learn more about the cellular and molecular mechanisms of repetitive Magnetic Stimulation (rMS)-induced synaptic plasticity we have established an in vitro model of rMS using mature (= 18 days in vitro) organotypic mouse entorhino-hippocampal slice cultures. We assessed the effects of a high frequency rMS protocol on functional and structural properties of excitatory synapses of CA1 pyramidal neurons. Whole-cell patch-clamp recordings, immunohistochemistry, and time-lapse imaging techniques revealed that rMS induces a long-lasting increase in glutamatergic synaptic strength which is accompanied by structural remodeling of dendritic spines. Furthermore, our data indicate that rMS interferes with the molecular machinery which controls the NMDA-receptor dependent accumulation of AMPA-receptors at synaptic sites. These results provide first experimental evidence that rMS induces coordinated functional and structural plasticity of excitatory postsynapses, which is consistent with a long-term potentiation of excitatory synaptic strength.

Regional metabolite distribution in the human corpus callosum

Sabine Hofer, Jens Frahm¹

¹Max-Planck-Institut für biophysikalische Chemie, Biomedizinische NMR Forschungs GmbH, Am Fassberg 11, 37070 Göttingen, Germany

The corpus callosum (CC) is by far the largest fiber bundle in the human brain interconnecting the two cerebral hemispheres with more than 300 million fibers. Using diffusion-tensor MRI (DTI) and subsequent fiber tractography we recently revisited the topographical representation of different cortical areas and distinguished 5 segments containing fibers projecting into prefrontal (region I), premotor and supplementary motor (region II), primary motor (region III), and primary sensory areas (region IV) as well as into parietal, temporal, and occipital cortical areas (region V). The functional specialization of different segments reflects the specific aspects interhemispheric communication. For example, the density of fibers with a small diameter fiber (0.4-1.0 μm) and low conduction velocity (0.3-5.0 m/s) is most pronounced in the anterior CC (genu, region I) and decreases to a minimum in the posterior midbody (region III-IV) containing larger fibers (2-7 μm) with much higher velocities (40-70 m/s). These structural and functional differences are in line with the observation of the lowest fractional anisotropy in the posterior midbody as revealed by DTI.

In order to further elucidate the underlying cellular composition and properties of different CC segments, this study used in vivo localized proton magnetic resonance spectroscopy (MRS) to quantitatively determine metabolite profile in respective areas of the human CC. To properly cover callosal portions with small fiber bundles, gigantic fibers, and densely packed fibers, image-guided regions-of-interest for localized MRS were placed according to the new CC parcellation scheme (see above). The data revealed a tendency for higher concentrations of creatine, myo-inositol (astrocytic marker), glutamate and glutamine in the posterior midbody of the CC containing large myelinated fibers with high conduction velocities. In contrast, the concentration of N-acetylaspartate (NAA), commonly considered as a neuroaxonal marker, is lowest in the genu and highest in the splenium. These results indicate that neither dense myelinated fibers with large diameters (midbody area) nor a high density of smaller axonal bundles (genu) automatically lead to a high NAA concentration. Instead, the exact role of NAA in white matter and, in particular, within axonal compartments remains an open question.

Recruitment of BDNF signaling in hippocampal mossy fiber LTP induced by different high frequency stimuli

Elke Edelman, Petnoi Petsophonsakul¹, Angela Jahn¹, Sandra Schildt¹, Volkmar Leßmann^{1,2}

¹ Institute of Physiology and ² Center of Behavioral Brain Sciences (CBBS), Otto-von-Guericke University Magdeburg, Medical School, Leipziger Straße 44, 39120 Magdeburg, Germany

The neurotrophin brain-derived neurotrophic factor (BDNF) is a major regulator of synaptic plasticity in the CNS. Its role in hippocampal plasticity is best studied at Schaffer Collateral - CA1 synapses, while the role of BDNF in mossy fiber (MF-) LTP is still not clear. MF-LTP exhibits some unique features of plasticity (i.e., frequency facilitation and NMDA receptor independent presynaptic expression). By means of acute inhibition of BDNF/TrkB signaling (either with the tyrosine-kinase inhibitor k252a or with the BDNF scavenger TrkB-Fc), and chronic ~50% reduction of BDNF protein levels in heterozygous knockout (BDNF^{+/-}) mice, we now investigated the requirement of BDNF signaling in MF-LTP induced with different induction protocols.

Recently we established field potential recordings in the CA3 region of acute slices from 8-10 weeks old, male C57Bl/6J mice. MF-signals were identified on the basis of the pronounced short-term plasticity and frequency facilitation. MF-LTP was induced in the presence of 50µM DL-APV by a 50Hz stimulation protocol (3x 50Hz for 1s, at 0.05Hz) and blocked by bath application of TrkB-Fc or k252a (TrkB-Fc LTP: 138.9±1.5% vs. control LTP: 172.3±1.9%; k252a: 122.0±1.6% vs. DMSO control: 155.5±1.9%) or by chronic reduction of BDNF (BDNF^{+/-}: 128.6±1.9% vs. BDNF^{+/+}: 148.9±2.1%). The residual MF-LTP seemed to be mediated by BDNF independent mechanisms. NMDA receptor dependent LTP at adjacent CA3-CA3 synapses, induced with a similar LTP protocol, was not dependent on BDNF (BDNF^{+/-}: 139.9±8.4% vs. BDNF^{+/+}: 146.8±11.5%).

Since BDNF has been shown to be recruited in a stimulus dependent manner in CA1 LTP (Kang et al., Neuron 1997), we established two further MF-LTP protocols (3x25Hz for 1s and 3x100Hz for 1s, each repeated at 0.05Hz), which lead to similar robust potentiation (3x25Hz LTP: 140.0±1.5%; 3x100Hz LTP: 146.1±2.8%). While MF-LTP strength was equal for all protocols, expression mechanisms seem to differ between the 3 protocols. We currently focused on acute inhibition of the MF-LTP by application of k252a, in order to analyze possible involvement of BDNF/TrkB signaling in LTP induced with 25Hz and 100Hz protocols.

As a secondary topic of the ongoing study, we focus on the residual MF-LTP left after inhibition of BDNF/TrkB signaling. Since MF-LTP is described to be dependent on cAMP signaling (e.g., Weisskopf et al., Science 1994), we investigate whether the remaining MF-LTP after inhibition of BDNF/TrkB signaling depends in intact cAMP pathways.

This is, to our knowledge, the first study, focusing on acute BDNF effects in MF-LTP. Taken together, our results suggest that BDNF is critically involved in the expression of MF-LTP when induced with a mild 50Hz stimulation protocol. We will further investigate the contribution of BDNF/TrkB signaling to MF-LTP in respect of stimulation frequency during LTP induction.

This work is supported by the Schram-Stiftung and by CBBS/EFRE.

Dopaminergic regulation of spike-timing dependent plasticity in CA1 of the hippocampus depends on the induction protocol

Efrain A Cepeda, Elke Edelman¹, Volkmar Leßmann^{1,2}

¹Institute of Physiology, ²Center of Behavioral Brain Sciences (CBBS), Otto-von-Guericke University Magdeburg, 39120 Magdeburg, Germany

Neuromodulators like catecholamines, acetylcholine and serotonin are relevant factors altering learning and memory formation. Since long-term potentiation (LTP) and long-term depression (LTD) are considered as neuronal correlates for learning and memory formation, investigation of neuromodulator functions in synaptic plasticity is essential for understanding of the mechanisms involved in the processes. Until recently, high frequency stimulation protocols were used predominantly to examine neuromodulator functions in synaptic plasticity. Little is known for physiological more relevant LTP protocols and their respective neuromodulation. In this study we used spike timing dependent plasticity (STDP) protocols to induce timing-dependent (t-)LTP or t-LTD in acute hippocampal slices of rats, which is a LTP protocol depending on low frequency and precisely timed activation of pre- and postsynaptic cells, to investigate dopaminergic modulation of STDP.

We established different STDP protocols with distinct postsynaptic action potential (AP) firing patterns, but equal numbers of presynaptic activation (leading to excitatory postsynaptic potentials; EPSP) and equal pairing frequencies (i.e., 1EPSP/1AP, 1EPSP/2AP and 1EPSP/4AP, all at 0.5Hz). In order to keep the total number of stimulations equal for each protocol, repeat number was reduced with increasing postsynaptic activation. All three protocols lead to robust t-LTP in response to positive pairing, and t-LTD upon negative pairing (t-LTP for 1EPSP/1AP: 1.7 ± 0.1 ; 1EPSP/2AP: 2.0 ± 0.4 ; 1EPSP/4AP: 1.8 ± 0.2 ; t-LTD for 1AP/1EPSP: 0.8 ± 0.1 ; 4AP/1EPSP: 0.8 ± 0.1).

In order to investigate neuromodulation of hippocampal STDP, we first focussed on dopamine which is known to regulate conventional LTP in the hippocampus (see e.g., Lisman & Grace, *Neuron* 2005). While the 1EPSP/1AP and 1EPSP/2AP protocols could be blocked by D1 receptor antagonist SCH23390 or rescued after dopamine depletion by application of exogenous dopamine (see e.g., Edelman & Lessmann, *Front. Syn. Neurosci.* 2011), t-LTP induced by the 1EPSP/4AP protocol was independent of postsynaptic cAMP/PKA signaling when cAMP signaling was inhibited by application of Rp-cAMPS (plasticity in the presence of Rp-cAMPS: 2.8 ± 0.7 vs. control STDP: 1.5 ± 0.3 , $p > 0.05$). These data suggest a molecular switch from dopamine dependent to dopamine independent mechanisms of STDP by increasing postsynaptic activation from 1AP to 4AP. Interestingly, the 1EPSP/4AP induced t-LTP required intact BDNF/TrkB signaling, which – however – did not affect t-LTP in the response to the 1EPSP/1AP and 1EPSP/2AP protocols, which was sensitive to dopamine.

Currently we investigate dopaminergic function in more detail. We will focus on threshold modulation of t-LTP, changes in spike timing windows by dopamine and scrutinize dopaminergic modulation of t-LTD.

Our data suggest that dopamine is an important regulator of hippocampal synaptic plasticity evoked at low frequency and with low numbers of postsynaptic activity. However, higher postsynaptic activity recruits dopamine independent pathways for t-LTP. Both mechanism of t-LTP may work together to fulfill the complex functions of memory formation.

This work is supported by CBBS/EFRE.

Poster Topic

T9: Glia, Glia-Neuron Interactions

- T9-1A** Electrogenic sodium-bicarbonate cotransporter NBCe1 mediates high bicarbonate sensitivity of mouse cortical astrocytes
Shefееq M. Theparambil, Joachim W. Deitmer
- T9-2A** Molecular mechanisms of subcellular trafficking and unconventional secretion of insulin-degrading enzyme, role of neuron-glia interaction
Konstantin Glebov, Marie Löchner, Olaf Merkel, Jochen Walter
- T9-3A** Cellular Proton Buffering and Acid/Base Transport in the Mouse Cerebellar Cortex
Marco D Alt, Joachim W. Deitmer
- T9-4A** Activity-dependent glucose transport in cell culture and acute cerebellar slices: a multiphoton study
Patrick Jakoby, Luis Felipe Barros, Joachim W. Deitmer
- T9-5A** Active uptake of SR101 into hippocampal astrocytes
Christian Schnell, Yohannes Hagos, Swen Hülsmann
- T9-6A** The lack of cortactin leads to reduced intercellular signaling in astrocytes
Stefanie Schweinhuber, Klemens Rottner, Martin Korte, Martin Rothkegel
- T9-1B** Lesion-induced changes in glial glutamate transporter distribution and function
W. Karl Kafitz, Alexandra E. Schreiner, Martin C. Stock, Julia Langer, Christine R. Rose
- T9-2B** Distinct CD39 expression and activity in different activation states of microglia
Petya Georgieva, Larisa Bulavina, Adriana Rocha, Susanne Wolf, Vitali Matyash, Helmut Kettenmann
- T9-3B** Purified canine olfactory ensheathing cells promote formation and outgrowth of neurites from human NT2 neurons
Frank Roloff, Susanne Ziege, Sarah Strauss, Kerstin Reimers, Jeffery Donald Kocsis, Christine Radtke, Wolfgang Baumgärtner, Konstantin Wewetzer, Gerd Bicker
- T9-4B** The mouse medial habenula contains a specific non-stellate subtype of astrocyte expressing the ectonucleotidase NTPDase2
Kristine Gampe, Klaus Hammer, Ágnes Kittel, Herbert Zimmermann
- T9-5B** Nitric oxide / cyclicGMP regulates motility of a microglial cell line
Hannah Christina Scheiblich, Frank Roloff, Vikram Singh, Martin Stangel, Michael Stern, Gerd

- T9-6B** Calcium Signaling In Olfactory Ensheathing Cells Modulates Blood Vessel Diameter In The Olfactory Bulb
Kristina Buddrus, Christian Lohr
- T9-1C** Interaction between granule cells and secondary radial glial cells in postnatal dentate gyrus morphogenesis as revealed by Reelin signaling deficient mice
Bianka Brunne, Jasmine Pahle, Michael Frotscher, Hans H Bock
- T9-2C** Modulation of purinergic system and extracellular matrix reverts maladaptive plasticity associated to reactive gliosis in the spinal cord
Michele Papa, Giovanni Cirillo, Maria Rosaria Bianco, Lorenza Marcello, Carlo Cavaliere, Lilia Alberghina, Annamaria Colangelo
- T9-3C** Absence of glial alpha-dystrobrevin causes abnormalities of the blood-brain barrier and progressive brain edema
Chun-Fu Lien, Sarajo Kumar Mohanta, Malgorzata Frontczak-Baniewicz, Jerome Swinny, Barbara Zablocka, Dariusz C Górecki
- T9-4C** Spatial and developmental heterogeneity of calcium signaling in olfactory ensheathing cells
Christian Lohr, Anne Thyssen, Kristina Buddrus, Michael Doengi, Maren Stavermann, James A. StJohn, Jenny A. Ekberg, Joachim W. Deitmer
- T9-5C** HIGH-THROUGHPUT MASS SPECTROMETRY OF THE ASTROCYTIC SECRETOME REVEALS NEURON-DEPENDENT SECRETION DYNAMICS
Sidney Cambridge, Michael Stiess, Frank Bradke, Walter Nickel, Matthias Mann
- T9-6C** Modulation of spontaneous inhibitory input on Purkinje neurons of the cerebellar cortex
Ramona Rudolph, Joachim W. Deitmer
- T9-1D** Large-scale astrocytic calcium waves in mouse cortex *in vivo*
Rita Förster, Helmuth Adelsberger, Xiaowei Chen, Arthur Konnerth
- T9-2D** Cuprizone (bis (cyclohexylidenehydrazide)) is selectively toxic for mature oligodendroglia
Karelle BENARDAIS, Alexandra Kotsiari, Jelena Škuljec, Paraskevi Koutsoudaki, Viktoria Gudi, Franca Franke, Thomas Skripuletz, Martin Stangel
- T9-3D** Astrocytes in the lateral superior olive express different types of neurotransmitter transporters
Jonathan Stephan, Eckhard Friauf
- T9-4D** Schwann cell depletion unravels special neurite growth-promoting capacity and growth factor responsiveness of olfactory mucosa-derived olfactory ensheathing cells
Konstantin Wewetzer, Wolfgang Baumgärtner, Kerstin Schöne, Susanne Ziege
- T9-5D** Microglia cell proliferation in the ipsi- and contralateral retina after acute retinal ischemia/reperfusion in the mouse retina *in vivo*
Christian Walter Schmeer, Melanie Krug, Stefanie G Wohl, Otto W. Witte

T9-6D Cognition without myelin - auditory discrimination in shiverer mice
Livia de Hoz Garcia-Bellido, Klaus-Armin Nave

Electrogenic sodium-bicarbonate cotransporter NBCe1 mediates high bicarbonate sensitivity of mouse cortical astrocytes

Shafeeq M. Theparambil, Joachim W. Deitmer¹

¹TU kaiserslautern, General Zoology, 3049, 67653 Kaiserslautern, Germany

Transport of base equivalent (HCO_3^-) across the membrane is a crucial process to maintain the intracellular and extracellular proton concentrations within a narrow physiological range. The electrogenic sodium-bicarbonate cotransporter (NBCe1, *SLC4 A4*) is a major base transporter in eukaryotes and expressed in many tissues, especially in epithelial cells. NBCe1 may transport significant amounts of bicarbonate into and out of the cell. Three different splice variants of *SLC4A4* have been identified as NBCe1-A, NBCe1-B and NBCe1 C isoforms and are expressed in kidney, pancreas and brain. In the brain, NBCe1 is predominantly expressed in glial cells and operates with a transport stoichiometry of $1\text{Na}^+:2\text{HCO}_3^-$. In the present work, we have studied the bicarbonate sensitivity of NBCe1, in primary cultured mouse cortical astrocytes (C57BL6/N) using live cell fluorescence imaging with confocal microscope and BCECF-AM as a proton sensitive fluorescence probe. We have also used the primary cortical astrocyte culture from NBCe1-KO mouse to compare the NBCe1-mediated processes in WT astrocyte culture. Bicarbonate dose response protocols suggest that NBCe1 has a very high affinity for bicarbonate ($K_m < 1\text{mM}$). Due to this high affinity for bicarbonate NBCe1 can sensitize even residual bicarbonate concentrations of $150\text{-}300\mu\text{M}$ present in nominally bicarbonate-free extracellular solutions (buffered with HEPES). The removal of residual bicarbonate by saturating extracellular buffer (HEPES) with $100\% \text{O}_2$ reduced these NBCe1-mediated intracellular proton changes significantly. In astrocytes of NBCe1-KO mice cytosolic H^+ changes could not be detected at HCO_3^- concentrations lower than 3mM . Due to the high sensitivity of NBCe1 for HCO_3^- in cortical astrocytes, we postulate that NBCe1 is a $\text{HCO}_3^-/\text{CO}_2/\text{H}^+$ sensor, which, in addition to promote cellular H^+ regulation in astrocytes, may have physiological significance e.g. for energy metabolism and processes activated by HCO_3^- -dependent soluble cAMP.

Supported by the Deutsche Forschungsgemeinschaft (DE 231/24-1)

Molecular mechanisms of subcellular trafficking and unconventional secretion of insulin-degrading enzyme, role of neuron-glia interaction

Konstantin Glebov, Marie Löchner¹, Olaf Merkel¹, Jochen Walter¹

¹University Hospital Bonn, Neurology, Sigmund Freud str 25, 53127 Bonn, Germany

Insulin-degrading enzyme (IDE) is a Zn²⁺ metalloprotease with a characteristic inverted catalytic motif. IDE is ubiquitously expressed and degrades various peptide substrates including insulin, endorphin as well as the amyloid-beta peptide. While being known for more than 50 years and recognized as a key enzyme for many biological processes, IDE remains poorly characterized in terms of functional domains and biological function besides its catalytic properties.

Up to now only few interaction partners of IDE have been identified. Our work indicates that IDE can associate with F-actin via the SlyX domain. Interestingly, phosphorylation of a serine residue, close to the SlyX domain, negatively regulates IDE/F-actin association. While this interaction might affect IDE unconventional secretion, it is possible to suggest that such interaction might have other functional significance in glia cells.

While being a cytosolic protein, IDE can be found on the membrane and in the nucleus. Since IDE lacks a characteristic signal sequence that targets the protein to the classical secretory pathway, IDE release involves unconventional mechanisms. However, functional domains of IDE involved in its secretion remain elusive. Recently, we identified a novel amino acid motif (⁸⁵³EKPPHY⁸⁵⁸) close to the C-terminus of IDE. Because of its close homology to an amino acid sequence found in bacterial proteins belonging to a SlyX family, we propose to call it SlyX motif. Mutagenesis revealed that deletion of this motif strongly decreased the release of IDE, while deletion of a potential microbody targeting signal at the extreme C-terminus had little effect on secretion.

Inability to identify a signaling pathway that regulates unconventional secretion of IDE, we screened for neurotransmitters that modulate IDE release. Our findings suggest that serotonin efficiently stimulates the release of IDE from microglia cells via activation of 5-HT_{2a/b} and 5-HT₄ receptors. Activation of these receptors leads to a stimulation of PLC and subsequent Ca²⁺ release via two distinct pathways. First, activation of 5-HT_{2a/b} receptors activates the PLC/Ca²⁺ pathway via G_{AQ} protein. Second, 5-HT₄ also stimulates the PLC/Ca²⁺ pathway via cAMP-mediated activation of Rap1/epac1/2. In addition, we have demonstrated that primary neurons can stimulate IDE release from the microglia cells.

Cellular Proton Buffering and Acid/Base Transport in the Mouse Cerebellar Cortex

Marco D Alt, Joachim W. Deitmer¹

¹TU Kaiserslautern, General Zoology, P.O. Box 3049, 67653 Kaiserslautern, Germany

The cytosolic concentration of free protons is regulated by a variety of buffers and membrane transport of acid/base equivalents. Even small shifts in pH may affect protein function, fluidity of the membrane, and most metabolic processes. We have performed calibrated in situ live-cell imaging with the proton-sensitive fluophore BCECF to quantify the intracellular proton buffer capacity. We found that only one proton in 400000 is unbound and thereby chemically active, and that about 50% of this buffer capacity is mediated by the $\text{CO}_2/\text{HCO}_3^-$ buffer system and the other 50% by intrinsic buffers. We have investigated the role of carbonic anhydrase (CA), which catalyses the reaction from CO_2 and H_2O to HCO_3^- and H^+ . We used CAII and CAIV knockout (KO) models to isolate the contribution of the different isoforms to the dynamics of the $\text{CO}_2/\text{HCO}_3^-$ buffer system. In Bergmann glia, addition and removal of $\text{CO}_2/\text{HCO}_3^-$ showed that the extracellular CAIV enhances CO_2 -induced intracellular acidification, while CAII enhances CO_2 -induced acidification and also the alkalinisation upon CO_2 removal. The rates of acidification and alkalinisation in both KO and WT were significantly reduced in the presence of the CA blocker 6-Ethoxy-2-benzothiazolsulfonamid (10 μM). The expression level of CAII and CAIV was monitored by Western blotting. A major part of the transmembrane acid/base transport is coupled to the Na^+ gradient. We were able to determine the cell type-specific contribution of the sodium-bicarbonate cotransporter NBCe1 and the sodium proton exchanger NHE in $[\text{H}^+]$ regulation. The removal of sodium from the external solution caused a fast cytosolic acidification. In WT Bergmann glia, 75% of $[\text{H}^+]$ regulation was mediated by HCO_3^- , while HCO_3^- did not contribute in NBCe1-KO mice. These results provide new insights into cellular proton-coupled processes that so far have not been described in acute neural tissue. Supported by the DFG (De 231/24-1)

Activity-dependent glucose transport in cell culture and acute cerebellar slices: a multiphoton study

Patrick Jakoby, Luis Felipe Barros², Joachim W. Deitmer¹

¹TU Kaiserslautern, General Zoology, 3049, 67653 Kaiserslautern, Germany;

²Centro de Estudios Científicos (CECS), Valdivia, Chile

Glucose is an essential energy source required to maintain the metabolism of neurons and astrocytes. In previous studies, we found a preferential uptake and metabolism of the fluorescent glucose analogue 2-(N-7-nitrobenz-2-oxa-1, 3-diazol-4-yl-amino)-deoxy-D-glucose (2-NBDG) in cerebellar Bergmann glial cells as compared to adjacent Purkinje cells.

We have now also used an adenovirally transduced FRET-based glucose nanosensor to monitor intracellular glucose concentrations of cultured astrocytes. In the presence of 100 μ M glutamate, we found an increased activity of glucose transporters, followed by a stimulation of glucose catabolism. We then asked, if in acute brain slices increased glucose uptake could also be observed in neurons or glial cells. Real time experiments in cerebellar slices using a two-photon microscope revealed a similar glutamate-induced stimulation of 2-NBDG uptake in Bergmann glial cells. In addition, this effect was also elicited by D-aspartate, an analogue for glutamate transport. The glutamate transport inhibitor TBOA suppressed the glutamate-induced modulation of the glucose transport in Bergmann glial cells. In contrast, there was no modulation of the 2-NBDG uptake in Purkinje cells by either of these compounds. These results suggest that in Bergmann glial cells, the transport is modulated in an activity-dependent manner. Increased glucose uptake was induced by the action of the energy-consuming excitatory amino acid transporter EAAT, which is responsible for the clearance of the synaptically released excitatory neurotransmitter glutamate. Since the brain is mainly fueled by glucose, and as neurons presumably consume more energy than glial cells, our results are in line with the hypothesis of the astrocyte-neuron lactate-shuttle, suggesting transfer of energy-rich metabolites from glial cells to glutamate releasing neurons.

Supported by DFG (SPP 1172 and GRK 845).

Active uptake of SR101 into hippocampal astrocytes

Christian Schnell, Yohannes Hagos³, Swen Hülsmann^{1,2}

¹Universitätsmedizin Göttingen, Abt. Neurophysiologie und Zelluläre Biophysik, Humboldtallee 23, 37073 Göttingen, Germany

²Exzellenzcluster "Mikroskopie im Nanometerbereich und Molekularphysiologie des Gehirns" (CNMPB)

³Universitätsmedizin Göttingen, Abt. Vegetative Physiologie, Humboldtallee 23, 37073 Göttingen, Germany

Sulforhodamine 101 is widely used as a specific marker of astrocytes in the neocortex and hippocampus of rodents. Using transgenic mice expressing EGFP under control of the astrocyte-specific GFAP promoter, we compared the labeling of astrocytes by SR101 in acute slices of the ventrolateral medulla (VLM) and the hippocampus. In contrast to the specific SR101-labeling of astrocytes in the stratum radiatum of the hippocampus, SR101-labeling of VLM astrocytes was not sufficient for reliable identification of astrocytes. To confirm selective labeling of astrocytes by SR101, we performed whole-cell voltage-clamp recordings of SR101⁺ and SR101⁻ EGFP-labeled astrocytes in the hippocampus and found no significant differences regarding membrane potential, input resistance and I-V relationship between SR101⁺ and SR101⁻ astrocytes. To reveal the reasons for the differences in SR101-labeling, we first used blockers of gap junction and pannexin hemichannels. Gap junction blocker carbenoxolone blocked SR101-uptake into hippocampal astrocytes. However, mefloquine, in low concentrations a blocker of pannexin hemichannels and in higher concentrations also a blocker of gap junction hemichannels did not prevent SR101-uptake. This excludes hemichannels as a route for SR101-uptake. When we used substrates (estron-3-sulfate and dehydroepiandrosterone sulfate) or blockers (rifampicin) of organic anion transporting polypeptides (OATP), SR101-uptake of hippocampal astrocytes was significantly reduced compared to CTRL conditions. In conclusion our results show, that SR101 is not passively diffusing into hippocampal astrocytes but actively transported via OATPs. Since it is difficult to discriminate pharmacologically between the OATPs, the identity of the OATP protein remains to be studied. Nevertheless, the weak labeling of VLM astrocytes can be explained by a smaller degree of expression different regulation of these OATPs in VLM astrocytes.

The lack of cortactin leads to reduced intercellular signaling in astrocytes

Stefanie Schweinhuber, Klemens Rottner², Martin Korte¹, Martin Rothkegel¹

¹TU Braunschweig, Zoological Institute, Cellular Neurobiology, Germany

²University of Bonn, Institute of Genetics, Germany

Neurons and glial cells represent the two main cell populations in the brain. Historically, neurons have been attributed to be the information processing unit of the brain. However, there is increasing evidence that glia cells also actively participate in synaptic transmission. To fulfill this role, the ability of glia cells to communicate with each other is required. Gap junctions are regarded as the primary pathway astrocytes utilize for intercellular communication. Secondly, the release of ATP through pannexin channels and thereby excitation of purinergic receptors on neighbouring cells plays a role in astrocytic communication. Intercellular gap junctional channels are composed of connexins. In astrocytes, Connexin43 (Cx43) and Connexin30 are the predominant isoforms. The depletion of Cx43 from astrocytes results in a faster migration and a reduced proliferation rate. siRNA mediated knockdown of Cx43 has been shown to lead to a higher amount of F-Actin, as well as an increased protrusion length and number per astrocyte (Olk et al., 2010). Although Cx43 does not directly interact with actin, it influences actin dynamics via a so far unknown pathway. Interestingly, Cx43 is described to bind to the actin associated protein cortactin (Ctn) (Vitale et al., 2009), which has been discovered as a major substrate of tyrosine kinase v-Src. The multidomain protein Ctn interacts via its SH3 domain with a wide range of proteins, e.g. WASP, dynamin and ZO-1. Additionally, cortactin colocalizes with the Arp2/3 complex and is thereby thought to mediate actin based motility. Cortactin was also shown to be vastly expressed in various regions of the mammalian brain. Interestingly, it is highly expressed in reactive astrocytes after a cortical lesion (Decourt et al., 2005). To elucidate the role of cortactin in the integration of connexin-dependent signaling in astrocytic networks, we compared primary astrocytic cultures derived from *cttn* knockout mice to those of wild type animals using calcium imaging techniques. Despite the lack of an obvious difference in the connexin localization in *cttn* deficient astrocytes, our data show a reduction in the number of cells participating in mechanically-induced calcium wave propagation. Additionally, the mean velocity of these calcium waves was significantly reduced. To prove the dominant role of connexins in this *cttn*-dependent astrocytic network events, astrocytes were also mechanically stimulated in the presence of either a gap junction inhibitor or apyrase. Hence, intercellular communication in cultured astrocytes is dependent on cortactin.

Lesion-induced changes in glial glutamate transporter distribution and function

W. Karl Kafitz, Alexandra E. Schreiner¹, Martin C. Stock², Julia Langer¹, Christine R. Rose¹

¹Heinrich Heine University, Institute of Neurobiology, Universitätsstr. 1, 40225 Düsseldorf, Germany

²Heinrich Heine University, Institute for Animal Developmental and Molecular Biology, Universitätsstr. 1, 40225 Düsseldorf, Germany

Rapid extracellular removal of glutamate, the major excitatory neurotransmitter in the CNS, is essential for normal brain function. This task is primarily accomplished by the action of the sodium-dependent, high-affinity transporters GLAST and GLT-1 (rodent analogous of EAAT1 and EAAT2), which are mainly expressed by astrocytes. Impairment or failure of GLAST and GLT-1 plays an important role in many pathological conditions.

In the present study, we analysed changes in glutamate transporter expression and function following a mechanical lesion in organotypic slice cultures of the mouse hippocampus using immunohistochemistry, western blots and dynamic imaging. The lesion was positioned perpendicular to the stratum pyramidale in the CA1 area and comprised the entire hippocampus proper. After three-six days, a glial scar had formed along the lesion site. Activated astrocytes in close proximity (100-150 µm) to the lesion ("scar cells") directed long, palisading GFAP-positive processes towards the lesion, had significantly swollen somata and lost their ability to take up SR101. Furthermore, some exhibited distinct clustering of GLAST and GLT-1 immunoreactivity. Scar cells showed greatly diminished increases in intracellular sodium in response to application of D-aspartate, an agonist for glutamate transporters. Astrocytes in the periphery to the lesion, in contrast, maintained their ability to take up SR101 and showed only slight up-regulation of GFAP, as well as less swollen cell bodies. Cells in the periphery displayed only marginal changes in glutamate transporter immunoreactivity and unaltered amplitudes of sodium changes in response to D-aspartate.

Taken together, our data show that mild astrogliosis in the periphery of a mechanical lesion is not accompanied by a significant change in glial glutamate uptake capacity. At the scar itself, a strong clustering of glutamate transporters is observed that apparently goes along with a severe functional reduction in glutamate uptake.

Supported by the DFG (Ro2327/4-3).

Distinct CD39 expression and activity in different activation states of microglia

Petya Georgieva, Larisa Bulavina¹, Adriana Rocha¹, Susanne Wolf¹, Vitali Matyash¹,
Helmut Kettenmann¹

¹MDC Berlin, Cellular Neurosciences, Robert-Rössle-Str.10, 13125 Berlin, Germany

Microglia are the resident immune cells in the brain and their motility and phagocytosis are regulated by purinergic signalling. Time course of adenosine triphosphate (ATP) signalling is controlled by ectonucleotidases, which rapidly dephosphorylate ATP. Microglia express only E-NTPDase I (CD39). We measured ATP degradation capacity by means of malachite green phosphate assay in microglial primary culture from wildtype and from CD39^{-/-} mice. ATP degradation rates of CD39^{-/-} microglia were beyond detection, indicating that CD39 is essential for ATP degradation by microglia. This effect could be observed in brain slices as well, where deletion of CD39 resulted in a decrease of ATP degradation ability by 25%. Next, we were interested in whether the microglial activation state would affect CD39 activity and expression. We stimulated primary microglial cultures from wildtype mice for 24h with LPS (classical activation), TGF β or IL10 (acquired deactivation) and IL13 (alternative activation) and subsequently measured the capacity of microglial cells to degrade ATP. Upon stimulation with LPS and TGF β the ability of the cells to degrade ATP, estimated by malachite green phosphate assay, was significantly reduced, while IL10 and IL13 stimulation did not induce a change. Furthermore, we performed quantitative PCR to test whether the alteration of ATP degradation is due to a change in CD39 mRNA expression. Indeed, stimulation with LPS strongly decreased microglial CD39 expression after both 6h and 24h. Taken together, our results indicate that in microglia, CD39 is essential for ATP degradation and its expression and activity change in different activation states.

Purified canine olfactory ensheathing cells promote formation and outgrowth of neurites from human NT2 neurons

Frank Roloff, Susanne Ziege², Sarah Strauss³, Kerstin Reimers³, Jeffery Donald Kocsis^{4,5}, Christine Radtke³, Wolfgang Baumgärtner^{2,6}, Konstantin Wewetzer^{2,6}, Gerd Bicker^{1,6}

¹Division of Cell Biology, University of Veterinary Medicine Hannover, 30173 Hannover, Germany

²Department of Pathology, University of Veterinary Medicine Hannover, 30559 Hannover, Germany

³Department of Plastic, Hand- and Reconstructive Surgery, Hannover Medical School, 30625 Hannover, Germany

⁴Department of Neurology and Center for Neuroscience and Regeneration Research, Yale University School of Medicine, New Haven, Connecticut 06510

⁵Neuroscience Research Center, Veterans Affairs Connecticut Healthcare System, West Haven, Connecticut 06516

⁶Center for Systems Neuroscience Hannover, Germany

Transplantation of olfactory ensheathing cells (OEC) and Schwann cells (SC) is a promising therapeutic strategy to facilitate axon regeneration and remyelination after spinal cord injury. However, the close phenotypic resemblance of OECs and SCs including the expression of marker molecules, e.g. the neurotrophin receptor p75 (p75NTR) and S100 so far did not allow selective identification and purification of OECs. Differential expression of HNK-1 and p75 (NTR) of freshly-dissociated and cultured ensheathing cells enabled us to deplete contaminating SCs from OEC preparations using magnet-activated cell sorting (MACS). Purified canine OECs from olfactory bulb (OB-OECs), olfactory mucosa (OM-OECs), and SCs from fibular nerve we analyzed regarding their motility using the scratch migration assay. Closure of an artificial “wound” scratched into a confluent monolayer was followed by monitoring the advancement of the cell front over 8hrs. Because this time interval is too short for significant cell proliferation, the presence of cells in the gap reflects migration. A quantitative evaluation shows that OB-OECs and SCs migrated faster than the OM-OECs. The OB-OECs and SCs covered a distance of about 120 µm in 8hrs, as compared to about 80 µm for the OM-OECs. Next, we investigated up-regulation of motility by bath application of pharmacological agents. Activation of the protein kinase C enhances motility of OB-OECs and OM-OECs whereas SCs are not affected. Pharmacological manipulation of NO/cGMP or cAMP/PKA signal transduction revealed no evidence for the involvement of these pathways.

Co-culturing human neurons on a layer of canine ensheathing cells resulted in an increased formation of neurites per neuron and elongation of these processes. The cell culture experiments using canine OECs and SCs serve to evaluate the potential therapeutic impact of the three glial cell types for repair of spinal cord injuries in a large animal model of spinal cord injury.

This study was supported by a DFG grant (FG 1103, BI 262/16-2)

The mouse medial habenula contains a specific non-stellate subtype of astrocyte expressing the ectonucleotidase NTPDase2

Kristine Gampe, Klaus Hammer¹, Ágnes Kittel², Herbert Zimmermann¹

¹Goethe University Frankfurt, Molecular and Cellular Neuroscience, Max-von-Laue Str. 13, 60438 Frankfurt am Main, Germany

²Department of Pharmacology, Institute of Experimental Medicine, Hungarian Academy of Sciences, Budapest, Hungary

Within the central nervous system synaptic transmission via ATP had been demonstrated for the first time in the rat medial habenula. This ATP release was action-potential sensitive, Ca²⁺-dependent and found to represent the only transmitter-gated Ca²⁺ entry pathway within the neuronal population of the medial habenula. Moreover the medial habenula includes purinergic systems capable of modifying synaptic transmission to direct purinergic synaptic inputs.

Here we identify the major ectonucleotidase responsible for the breakdown of extracellular ATP in the mouse medial habenula as ectonucleoside triphosphate diphosphohydrolase 2 (NTPDase2). Using both, immuno- and enzyme histochemical methods we show that the NTPDase2 is typically expressed by a non-stellate subpopulation of astrocytes. This subtype of astrocyte wraps around the densely packed neuronal populations and the myelinated fibre bundles of the stria medullaris. Immunoelectron microscopical analysis further revealed that NTPDase2 is associated with astrocytes surrounding neuronal cells bodies, with cellular processes in the neuropile sheathing presynaptic terminals, and with cellular end-feet making contact with the surface of capillaries. Analysis of mice expressing green fluorescent protein under control of the GFAP promoter showed that astrocytes in the medial habenula contain elongated processes extending through the neuropile. In contrast to the medial habenula, the characteristically stellate astrocytes localised in the lateral habenula lack NTPDase2 expression.

Our results suggest that the rodent medial habenula contains a specific subtype of astrocyte that strongly expresses the ectonucleotidase NTPDase2 in a strategic position to modulate purinergic transmission in this subnucleus.

Nitric oxide / cyclicGMP regulates motility of a microglial cell line

Hannah Christina Scheiblich, Frank Roloff¹, Vikram Singh^{2,3}, Martin Stangel^{2,3}, Michael Stern¹, Gerd Bicker^{1,3}

¹Division of Cell Biology, University of Veterinary Medicine Hannover, Germany

²Department of Neurology, Hannover Medical School, Germany

³Center for Systems Neuroscience Hannover, Germany

Nitric oxide (NO) is a membrane permeant signaling molecule which activates soluble guanylyl cyclase (sGC) and leads to the formation of cyclic GMP in target cells. Developmental studies in both vertebrates and invertebrates implicate an involvement of NO/cGMP signaling in neuronal and glial motility (Dev Neurobiol 68: 295-308, 2008; Development 136: 85-93, 2009; Glia 58: 1133-1144, 2010; Cell Mol Life Sci 68: 2089-2099, 2011). NO has been shown to be produced by injury-activated microglia. Here we analyze a potential role for NO signaling in the migration of a microglial cell line (BV-2). To test the motility of the microglial cells, we use a scratch migration assay, which measures cell migration during the closure of a "wound" that is scratched into a confluent cell monolayer. Closure of the gap is quantified by monitoring the advancement of the cell front over eight hours. Because this time interval is too short for significant cell proliferation, the presence of cells in the gap reflects migration. By employing small bioactive enzyme activators and inhibitors in both gain and loss of function experiments, we demonstrate that NO/cGMP signaling is a positive regulator of microglial cell migration. Further experiments address the improved motility of primary cultured rat microglia after NO/cGMP stimulation. Since NO signaling regulates cell movement from developing insects to mammalian nervous systems, this transduction pathway may have evolutionary conserved functions in cell motility.

This study is supported by a DFG grant (FG 1103, BI 262/16-2). We would like to thank Prof. M. Leist for the gift of the cell line.

Calcium Signaling In Olfactory Ensheathing Cells Modulates Blood Vessel Diameter In The Olfactory Bulb

Kristina Buddrus, Christian Lohr¹

¹University of Hamburg, Neurophysiology, Martin-Luther-King Platz 3, 20146 Hamburg, Germany

A specialized glial cell type in the olfactory bulb (OB), the olfactory ensheathing cells (OECs), enwraps bundles of axons in the olfactory nerve layer and contacts surrounding blood vessels. Several studies have already demonstrated that astrocytes are important modulators in the regulation of cerebral blood flow. In contrast, the interaction between OECs and the vasculature of the olfactory bulb has not been investigated in detail yet. Changes in the glial calcium (Ca^{2+}) level can lead to alterations in local blood flow by either causing vasoconstriction or vasodilation of neighboring arterioles. To study this context we evoked calcium signaling in single OECs by using laser photolysis of caged Ca^{2+} and simultaneously monitored the tone of adjacent vessels. Vessel diameter and glial cell calcium were measured using confocal imaging techniques. Photolysis of caged Ca^{2+} in OECs led to vasoconstriction of arterioles in 97.1% and to vasodilation in 2.9%. In studies performed in acute cortical brain slices, different substances such as lactate and prostaglandin E_2 have been described to elicit vasodilation of cerebral blood vessels dependent on glial Ca^{2+} . We intended to verify the effect of some of these substances in an in-toto preparation of the mouse OB. When lowering the oxygen level from 95% to 20% to enhance glycolysis and lactate release, only vasoconstriction occurred upon photolysis of caged Ca^{2+} in OECs. Furthermore, application of lactate, to increase the extracellular prostaglandin E_2 concentration, as well as elevation of external K^+ , to hyperpolarize smooth muscle cells (SMC) by Kir channels activation, did not evoke dilation of blood vessels in the OB. However, application of adenosine induced dilation of blood vessels in cortical brain slices and in the OB, independent of the oxygen concentration. We then precontracted arterioles of cortical brain slices and the OB with the thromboxane A_2 agonist U-46619 to induce physiological levels of arteriolar tone. Additional application of the group I metabotropic glutamate receptor agonist DHPG then caused arteriole dilation. The results suggest that in isolated brain tissue preparations, constriction is the predominant vasoresponse upon glial Ca^{2+} signaling, and that precontraction of blood vessels is required to evoke a physiological vessel tone and hence promote vasodilation.

Interaction between granule cells and secondary radial glial cells in postnatal dentate gyrus morphogenesis as revealed by Reelin signaling deficient mice

Bianka Brunne, Jasmine Pahle¹, Michael Frotscher¹, Hans H Bock²

¹University Medical Center Hamburg-Eppendorf, Center for Molecular Neurobiology Hamburg, Falkenried 94, D-20251 Hamburg, Germany;

²University of Freiburg, Center of Neurosciences, Albertstraße 23, D-79104 Freiburg, Germany

During the development of the dentate gyrus, the early embryonic radial glial scaffold is replaced around birth by a secondary glial scaffold. In most brain areas radial glial cells play an important role for neuronal migration, but until now it is not known to what extent these late dentate gyrus radial glial cells contribute to granule cell migration or positioning. These secondary radial glial cells have comparatively short processes, just about 100µm, i.e., a distance that neurons can cope with by nuclear translocation, a mode of migration not requiring a radial glial scaffold. Therefore, it seems unlikely that they support conventional radial glia-guided migration.

We used conditional disabled-1 (Dab1) mice to investigate the influence of these radial glial cells on granule cell positioning. Dab1 is an intracellular adaptor protein that is important for Reelin signaling. Reelin is a large secreted glycoprotein, which is sensed by neurons as well as radial glial cells. Ablation of Reelin signaling in the dentate gyrus leads to both a malpositioning of neurons and a failure of radial glial cells to build up an ordered radial scaffold. Selective ablation of Reelin signaling in neurons and glial cells, respectively, allowed us to discriminate to what extent both cell populations influence each other during dentate gyrus morphogenesis.

Our results support the idea that secondary radial glial cells have a guiding function for migrating granule cells that depends on Reelin signaling to glial cells. On the other hand, neuronal positioning has an important influence on secondary radial glial morphology. Taken together these data indicate a bidirectional interaction between neurons and glial cells in the dentate gyrus that is distinct from migratory mechanisms in the neocortex.

Modulation of purinergic system and extracellular matrix reverts maladaptive plasticity associated to reactive gliosis in the spinal cord

Michele Papa, Giovanni Cirillo¹, Maria Rosaria Bianco¹, Lorenza Marcello¹, Carlo Cavaliere¹, Lilia Alberghina^{2,3}, Annamaria Colangelo^{2,3}

¹Second University of Naples, Department of Mental, Physical and Preventive Medicine, Via L. Armanni 5, 80138 Naples, Italy

²SYSBIO Center of Systems Biology, Milano, Italy

³Laboratory of Neuroscience —R. Levi-Montalcini, Dept. of Biotechnology & Biosciences, University of Milan-Bicocca, Milano, Italy

In the spinal cord, reactive gliosis is the common feature following acute or chronic peripheral nerve injury. The astrocytes undergo to a wide phenotypic rearrangement characterized by an extensive remodeling of the cytoskeleton. This morphological hallmark is associated to dramatic changes of several glial proteins involved in astrocytic function, modulating synaptic efficacy and metabolic glia-neuronal coupling. Gliopathy, cause the decrease of glial amino acid transporters, associated to imbalance of several vesicular transporters, affecting astrocytes role in tripartite synapse. The combined changes of the glutamate-cystine antiporter system, reducing glutathione availability, alters the glia-neuronal metabolic coupling, impairing mitochondrial complex performance. All these changes are associated to an extensive neuronal network maladaptive plasticity with a substantial reversal of Glutamate/GABA compartments. In our previous studies we show that both purinergic system and extracellular matrix modulation by different modalities play a key role in reducing gliopathy and rescuing maladaptive plasticity. To this aim we analyze how MMP inhibition and purinergic system, individually and cooperatively, could induce cellular determinants of neuroglial networks plasticity through transcriptional programming resulting from epigenetic modifications.

Male Sprague Dawley rats underwent to spared sciatic nerve injury (SNI) and treated: A) oATP, 3 days; B) oATP 7days; C) GM6001, 3 days; D) GM6001, 7 days; E) oATP+GM6001, 3 days; F) oATP+GM6001, 7 days; G) vehicle; H) naïve. Spinal cord at lumbar enlargement was analyzed by immunoblotting and immunocytochemistry, for the expression of different markers of the reactive gliosis: Iba1 for microglia; GFAP, S100-beta for macroglia; HDAC1, HDAC2, GADD45B, for epigenetic modifications, NF-KB for transcriptional factors; Cyclin E1 expression for synaptic plasticity; Pro-NGF for neurotrophinergic system; RBPJ for Notch modulation.

Results show a cross talk between the two systems in rescuing maladaptive plasticity.

Absence of glial alpha-dystrobrevin causes abnormalities of the blood-brain barrier and progressive brain edema

Chun-Fu Lien, Sarajo Kumar Mohanta⁴, Malgorzata Frontczak-Baniewicz², Jerome Swinny¹, Barbara Zablocka³, Dariusz C Górecki¹

¹Molecular Medicine, School of Pharmacy and Biomedical Sciences, University of Portsmouth, Portsmouth, United Kingdom.

²Electron Microscopy and ³Molecular Biology Unit, Mossakowski Medical Research Centre, Warsaw, Poland.

⁴Present address: Institute of Vascular Medicine, Friedrich Schiller University, Jena, Germany.

The blood-brain barrier (BBB) plays a key role in maintaining brain functionality. Although mammalian BBB is formed by endothelial cells, its function requires interactions between endotheliocytes and glia. To understand the molecular mechanisms involved in these interactions is currently a major challenge. We show here that α -dystrobrevin (α -DB), a protein contributing to dystrophin-associated protein (DAP) scaffolds in astrocytic endfeet is essential for the formation and functioning of BBB. Absence of α -DB in null brains resulted in abnormal brain capillary permeability, progressively escalating brain edema and damage of the neurovascular unit. Analyses in situ and in 2D and 3D in vitro models of BBB containing α -DB-null astrocytes demonstrated these abnormalities to be associated with loss of aquaporin-4 water and Kir4.1 potassium channels from glial endfeet, formation of intracellular vacuoles in α -DB-null astrocytes and defects of the astrocyte-endothelial interactions. These caused deregulation of tight-junction proteins in the endothelia. Importantly, α -DB but not dystrophins showed continuous expression throughout development in BBB models. Thus, α -DB emerges as a central organizer of DAP in glial endfeet and a rare example of a glial protein with a role in maintaining BBB function. Its abnormalities might therefore lead to BBB dysfunction.

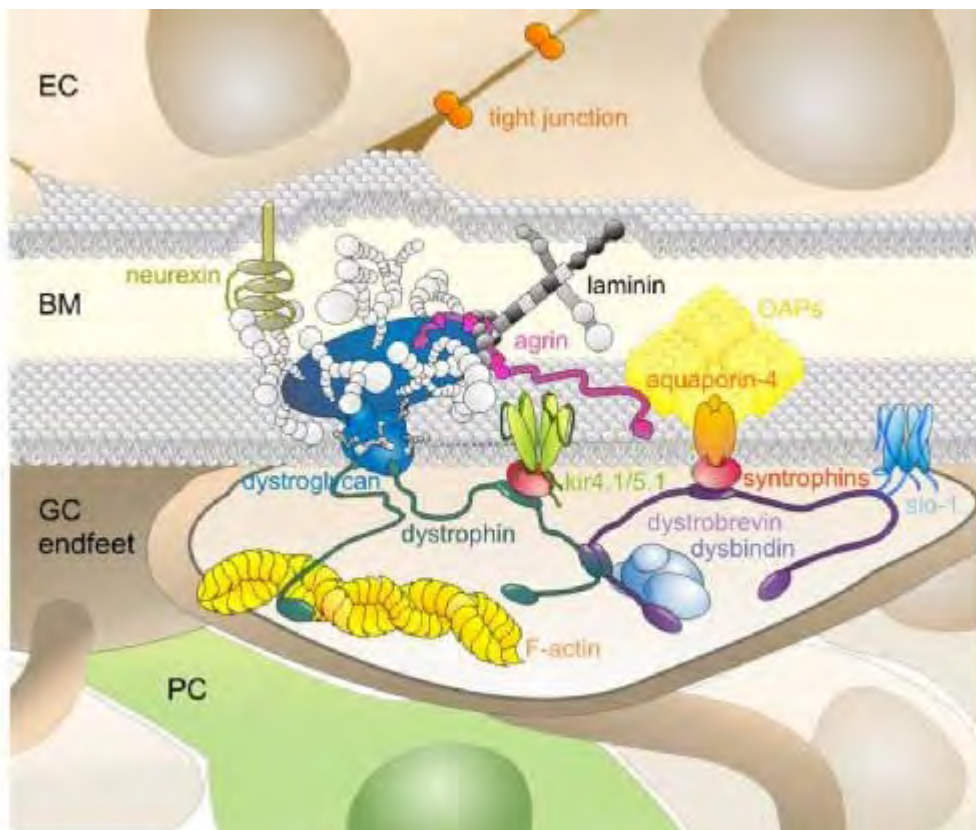

Spatial and developmental heterogeneity of calcium signaling in olfactory ensheathing cells

Christian Lohr, Anne Thyssen², Kristina Buddrus¹, Michael Doengi², Maren Stavermann², James A. StJohn³, Jenny A. Ekberg³, Joachim W. Deitmer²

¹University of Hamburg, Neurophysiology, Biocenter Grindel, Martin-Luther-King-Pl. 3, 20146 Hamburg, Germany

²University of Kaiserslautern, General Zoology, POB 3049, 67653 Kaiserslautern, Germany

³Eskitis Institute for Cell and Molecular Therapies, Griffith University, Nathan 4111, Brisbane, QLD, Australia

Olfactory ensheathing cells (OECs) are specialized glial cells in the mammalian olfactory system supporting growth of axons from the olfactory epithelium into the olfactory bulb. OECs in the olfactory bulb can be subdivided into OECs of the outer nerve layer and the inner nerve layer according to the expression of marker proteins and their location in the nerve layer. In the present study, we have used confocal calcium imaging of OECs in acute mouse brain slices and olfactory bulbs in toto to investigate physiological differences between OEC subpopulations. OECs in the outer nerve layer, but not the inner nerve layer, responded to glutamate, ATP, serotonin, dopamine, carbachol and phenylephrine with increases in the cytosolic calcium concentration. The calcium responses consisted of a transient and a tonic component, the latter being mediated by store-operated calcium entry. Calcium measurements in OECs during the first three postnatal weeks revealed a down-regulation of mGluR1 and P2Y1 receptor-mediated calcium signaling within the first two weeks, suggesting that the expression of these receptors is developmentally controlled. In addition, electrical stimulation of sensory axons evoked calcium signaling via mGluR1 and P2Y1 only in outer nerve layer OECs. Down-regulation of the receptor-mediated calcium responses in postnatal animals is reflected by a decrease in amplitude of stimulation-evoked calcium transients in OECs from postnatal day 3 to 21. In summary, the results presented reveal striking differences in receptor responses during development and in axon-OEC communication between the two subpopulations of OECs in the olfactory bulb.

HIGH-THROUGHPUT MASS SPECTROMETRY OF THE ASTROCYTIC SECRETOME REVEALS NEURON-DEPENDENT SECRETION DYNAMICS

Sidney Cambridge, Michael Stuess^{3,4}, Frank Bradke^{3,5}, Walter Nickel⁶, Matthias Mann²

¹University of Heidelberg, Cell Biology and Anatomy, Im Neuenheimer Feld 307, 69120 Heidelberg, Germany

²Max-Planck-Institute of Biochemistry, 82152 Munich-Martinsried, Germany

³Max-Planck-Institute of Neurobiology, 82152 Munich-Martinsried, Germany

⁴Biozentrum, University of Basel, Klingelbergstrasse 50, 4056 Basel, Switzerland

⁵Deutsches Zentrum für Neurodegenerative Erkrankungen, 51375 Bonn, Germany

⁶Heidelberg University Biochemistry Center, Im Neuenheimer Feld 328, 69120 Heidelberg, Germany

The astrocytic secretome is vital for axon guidance, neurogenesis, and regeneration. We used in-depth SILAC-label based mass spectrometry for functional analysis of astrocyte secretion in vitro. For the first time, we provide precise quantitation of the extra- to intracellular protein ratio of more than two thousand identified proteins, including many that were previously not known to be secreted. Functionally, the secretome of forebrain astrocytes specifically changed within hours after adding unlabelled forebrain neurons vs. cerebellar hindbrain neurons. We describe an exhaustive set of specific patterns of protein up- and downregulation between control and neuron-exposed conditions that, among other functions, provided positive feedback to forebrain neurons and negative feedback to hindbrain neurons. Our data thus support a dynamic astrocytic secretome that maintains a diverse extracellular environment much more complex than previously assumed.

Modulation of spontaneous inhibitory input on Purkinje neurons of the cerebellar cortex

Ramona Rudolph, Joachim W. Deitmer¹

¹TU Kaiserslautern, General Zoology, P.O. Box 3049, 67653 Kaiserslautern, Germany

Purkinje neurons (PN) of the cerebellum are the exclusive output from the cerebellar cortex to the cerebellar nuclei. Their large dendritic tree receives many different inhibitory and excitatory inputs which are integrated in these neurons. Here we focus on the spontaneous inhibitory input from GABAergic molecular layer interneurons, namely basket and stellate cells. Besides neuronal interaction, there is also a special type of astrocyte, the Bergmann (BG) glia cells, closely associated with PN. BG cells enwrap the synapses and are assumed to take a versatile role for synaptic transmission. In BG, intracellular Ca^{2+} transients are evoked by purines, such as ATP and ADP, and by the ionotropic glutamate receptor agonist AMPA (Burnashev *et al.*, Science, Vol.256, 1992). In the present study we have used the whole-cell patch-clamp technique to record synaptic events in PN. We show that purines and AMPA reversibly modulate the frequency of spontaneous inhibitory postsynaptic currents (sIPSCs) in PN. We have hypothesized that a release of gliotransmitter from BG following the Ca^{2+} signals elicited by purines and/or AMPA, might be involved in contributing to the higher activity of interneurons and consequently an increase in the frequency of sIPSCs in PN. We have employed different antagonists of purinergic and glutamatergic receptors, and have also used transgenic mice deficient in specific receptors to evaluate the role of BG cells. Our results suggest a complex interplay between neurons and glial cells for tuning activity in the cerebellar cortical network.

Supported by the Deutsche Forschungsgemeinschaft.

Large-scale astrocytic calcium waves in mouse cortex *in vivo*

Rita Förster, Helmuth Adelsberger¹, Xiaowei Chen^{1,2}, Arthur Konnerth¹

¹Technische Universität München, Institute of Neuroscience, Biedersteinerstr. 29, 80802 Munich, Germany,

²Brain Research Center, Third Military Medical University, Chongqing, China

Transient elevations of the intracellular calcium concentration occur in astrocytes of the mammalian brain either spontaneously or in response to sensory stimulation (Wang et al., 2006). These transients, or 'cytosolic calcium surges' (Hirase et al., 2004), are thought to play a role in the modulation of neuronal activity and the regulation of blood flow. Such calcium signals were observed in various cortical regions (Schummers et al., 2008; Hirase et al., 2011) and in the hippocampus (Kuga et al., 2011) of mice. In the present study we explored the range of action of astrocytic calcium signals throughout the mouse cortex. For recording wide range astrocytic calcium signals, we exposed the cortex from the anterior end of the visual cortex to the prefrontal cortex (4-5 mm) and selectively stained astrocytes by surface loading (Hirase et al., 2004) using the fluorescent calcium dye Fluo-8. The specificity of astrocytic dye-loading was verified by two-photon calcium imaging and counterstaining with sulforhodamine 101. Population activity of astrocytes was monitored by means of a sensitive CCD-camera mounted onto a microscope (Stroh et al., 2011). Recordings were performed at different depths of anesthesia using the volatile anesthetic isoflurane. The depth of anesthesia was verified by simultaneous electrocorticogram (ECoG) recordings. In deeply anesthetized mice, at isoflurane concentrations of 2 % (Vol/Vol O₂), the ECoG recordings revealed, as expected, neuronal slow oscillations. Remarkably, there was no evidence for astrocytic calcium signaling. The gradual reduction of the level of anesthesia was associated with an increased probability of large-scale astrocytic activity throughout the entire cortex. These wave-like calcium signals had rise times of 6.2 ± 1.5 s seconds and lasted for 24.5 ± 10.1 s. At the lowest level of anesthesia tested (0.3% isoflurane), these ultraslow calcium waves occurred at a frequency of 2.7 waves/min. Interestingly, astrocytic calcium waves were associated with a marked depression of neuronal ECoG activity, suggesting the existence of pronounced neuron-glia interactions. This conclusion was further supported by the observation that the astrocytic calcium waves were reversibly blocked when blocking neuronal activity by tetrodotoxin (TTX, 5 μ M). A surprising feature of these ultraslow calcium waves was that they occurred nearly simultaneously throughout the cortex, without an obvious local initiation site and without evidence for slow wave propagation, as found in previous *in vitro* studies. Taken together, our results indicate that recurrent and large-scale correlated glia activity is a hallmark of wakefulness in the mammalian cortex.

References:

- Wang X. et al. (2006). Astrocytic Ca²⁺ signalling evoked by sensory stimulation *in vivo*. *Nat Neurosci.* 6, 816-23.
- Schummers J. et al. (2008). Tuned responses of astrocytes and their influence on hemodynamic signals in the visual cortex. *Science.* 320, 1638-43
- Kuga N. et al. (2011) Large-scale calcium waves traveling through astrocytic networks *in vivo*. *J Neurosci.* 31, 2607-14.
- Hirase H. et al. (2004) Calcium dynamics of cortical astrocytic networks *in vivo*. *PLoS Biol.* E96.
- Stroh et al. (2011) Optogenetic analysis of slow oscillation-associated cortico-thalamic calcium waves *in vivo*. Annual Meeting of the Society for Neuroscience, Washington, DC. 305.24/YY6

Cuprizone (bis (cyclohexylidenehydrazide)) is selectively toxic for mature oligodendroglia

Karelle BENARDAIS, Alexandra Kotsiari², Jelena Škuljec³, Paraskevi Koutsoudaki⁴, Viktoria Gudi¹, Franca Franke⁵, Thomas Skripuletz¹, Martin Stangel¹

¹Medizinische Hochschule Hannover, Neuroimmunologie and Neurologie department, Carl-Neuberg Str. 1, 30627 Hannover, Germany

²Department of Molecular Psychiatry, Hannover Medical School, Hannover, Germany

³Department of Paediatric Pulmonology, Allergology and Neonatology, Hannover Medical School, Hannover, Germany

⁴ Cellular and Molecular Neurobiology Laboratory, Athens, Greece

⁵ Department of Neurology, clinical and molecular neurogenetics, University of Lübeck, Germany

Cuprizone [bis (cyclohexylidenehydrazide)] induced toxic demyelination is an experimental animal model commonly used to study de- and remyelination in the central nervous system (CNS). In this model, mice are fed with the copper chelator cuprizone, which leads to oligodendrocyte death with subsequent demyelination. The underlying mechanisms of cuprizone induced oligodendrocyte death are still unknown and appropriate in vitro investigations to study these mechanisms are not available. Thus, we studied cuprizone effects on rat primary glial cell cultures and on the neuroblastoma cell line SH-SY5Y. Treatment of cells with different concentrations of cuprizone failed to show effects on the proliferation/survival of SH-SY5Y, microglia, astrocytes, and oligodendrocyte precursor cells (OPC). In contrast, differentiated mature oligodendrocytes were found to be significantly affected by cuprizone treatment. The toxic effect of cuprizone on mature oligodendrocytes was reduced when oligodendrocytes were co-cultured with astrocytes. These results demonstrate that the main toxic targets for cuprizone are mature oligodendrocytes while other glial cells including OPC are not or only marginally affected. This explains the selective demyelination induced by cuprizone in vivo.

Astrocytes in the lateral superior olive express different types of neurotransmitter transporters

Jonathan Stephan, Eckhard Friauf¹

¹University of Kaiserslautern, Animal Physiology Group, Erwin-Schoedinger-Strasse 13, 67663 Kaiserslautern, Germany

The lateral superior olive (LSO) is part of the superior olivary complex (SOC), and its neurons detect interaural level differences that enable sound source localization. Principal LSO neurons are surrounded by astrocytes that are well known for their contribution in neurotransmitter clearance from the synaptic cleft. As principal LSO neurons receive excitatory and inhibitory input from the ipsi- and contralateral ear, respectively, astrocytes in the LSO are expected to express several different types of excitatory as well as inhibitory neurotransmitter transporters at the same time.

In order to investigate the composition of neurotransmitter transporters in LSO astrocytes, 270- μ m-thick brainstem slices were cut from C57Bl6 wild type mice at postnatal day 10 to 12. Astrocytes in those acute brainstem slices were then labeled with the red fluorescent dye Sulforhodamine 101 (SR101) that specifically labels astrocytes in acute tissue slices (Kafitz et al., 2008). The SR101 labeling pattern showed an aggregation of astrocytes that mirrors the different SOC nuclei.

Next, identified astrocytes were patch-clamped and membrane currents and potentials were recorded. They displayed a highly negative membrane potential (-85 mV), a low membrane resistance (3 MO), and a linear or non-linear current-voltage (IV) relationship, as it is expected for classical astrocytes. Bath application of either glycine or GABA (each 1 mM) caused a peak inward current and a depolarization, respectively, which were both reduced during prolonged application by about 15 %. However, the GABA-induced current and depolarization were 50 to 80 % larger than those induced by glycine. Additionally, simultaneous application of both neurotransmitters had a 10 to 20 % smaller impact regarding membrane current and depolarization compared to the summated single effects, arguing for a reduction in their common driving force. Furthermore, the currents induced by both neurotransmitters were sensitive to the reduction of extracellular chloride (-85 %) and the glycine (GlyT1) and GABA (GAT3) transporter inhibitors sarcosine (-55 %) and SNAP5114 (-70 %), respectively. Interestingly, increasing the glycine concentration up to 50 mM was not sufficient to achieve a saturation regarding the transporter current, showing the strength of neurotransmitter uptake in astrocytes.

Taken together, our results demonstrate that identified SR101 positive astrocytes in the LSO express the inhibitory neurotransmitter transporters GlyT1 and GAT3. Furthermore, uptake of one neurotransmitter affects the uptake of the other. This is likely due to reduced driving forces as both investigated neurotransmitter transporters utilize the sodium, chloride as well as the electrical gradient. We assume that simultaneous activation of excitatory and inhibitory inputs to principal LSO neurons would result in a presumably complex modulation in the signal transduction as a result of altered neurotransmitter clearance by astrocytes.

Schwann cell depletion unravels special neurite growth-promoting capacity and growth factor responsiveness of olfactory mucosa-derived olfactory ensheathing cells

Konstantin Wewetzer, Wolfgang Baumgärtner^{2,3}, Kerstin Schöne², Susanne Ziege²

¹Hannover Medical School, Department of Functional and Applied Anatomy, Carl-Neuberg-Str. 1, 30625 Hannover, Germany;

²Center for Systems Neuroscience, Hannover, Germany; ³University of Veterinary Medicine Hannover, Department of Pathology, Bünteweg 17, 30559 Hannover

Olfactory ensheathing cells (OECs) and Schwann cells (SCs) are considered attractive candidates for cell transplantation-based therapy of the central nervous system (CNS). The long-lasting debate of whether OECs exert more potent effects than SCs, however, is still unresolved. This is due to the fact that cultured SCs display close antigenic homology with OECs thereby escaping selective visualization. Thus, it has remained unclear whether there are substantial SC contaminations in OEC preparations from the olfactory mucosa (OM) and olfactory bulb (OB). The central aim of this study was therefore to develop a protocol for the depletion of SCs from OEC preparations as a basis for a solid comparative analysis of OM-OECs, OB-OECs, and SCs regarding neurite growth-promoting effects and growth factor responsiveness. Cells were isolated from adult dogs as a translational model for human studies. First, we identified two cell surface markers (HNK-1, p75NTR) suitable for selective identification of SCs in primary adult canine OM and OB cell suspensions. Specific antibodies against these antigens were then used to deplete SCs from these preparations by magnet-activated cell sorting (MACS). Highly-purified and SC-free OM-OECs and OB-OECs were cocultured with either rat dorsal root ganglion (DRG) explants or dissociated DRG neurons and the effects on neurite growth were quantitatively evaluated in comparison with SCs maintained with neurons under the same conditions. Finally, proliferation and growth factor responsiveness of all three cell types was tested.

Immunofluorescent analysis of freshly-dissociated OM revealed that 56% of all CNPase-positive cells, representing both OECs and SCs, expressed HNK-1 or p75NTR indicating that the primary OM cell suspension contained as many SCs as OECs while OB primary cell suspensions contained lower numbers of SCs. The developed two-step purification protocol then allowed the quantitative elimination of SCs from OM and OB cell suspensions. Growth and complexity of neurites defined as the number of branching points per neuron was highest in the presence of OM-OECs. Interestingly, the percentage of the total neurite distance that covered glial cell surfaces was least in the OM-OEC group and significantly different from both OB-OECs and SCs indicating that secreted molecules crucially defined the special OM-OEC properties. While the three cell types did not differ in proliferation rate and response to established mitogens only in vitro growth of OM-OECs was promoted by ciliary neurotrophic factor. This study provides the first evidence that SC-free OM-OEC preparations display special and intrinsic properties and underscores the relevance of the nasal mucosa as a source for regeneration-promoting glia. Moreover, it provides a blueprint for similar studies in rodents. The neurite growth-promoting and remyelination capacity of SC-free OEC preparations in vivo are currently under investigation.

Microglia cell proliferation in the ipsi- and contralateral retina after acute retinal ischemia/reperfusion in the mouse retina in vivo

Christian Walter Schmeer, Melanie Krug¹, Stefanie G Wohl², Otto W. Witte¹

¹Hans-Berger Department of Neurology, Experimental Neurology, Erlanger Allee 101, 07747 Jena, Germany. ²Department of Biological Structure, University of Washington, Seattle, USA

Retinal ischemia is a serious and common cause of visual loss in a number of ocular diseases including acute glaucoma, branch retinal artery occlusion, diabetic retinopathy, and hypertensive vascular disease. Microglia as immunocompetent cells of the central nervous system (CNS) become activated after injury. Activated microglia proliferate and phagocytose neuronal debris, however, there are significant differences in microglial response to lesion. The aim of this study was to characterize the microglia cell proliferative response in ipsi- and contralateral retinae after different ischemia durations in the mouse eye in vivo. We used a model of transient global retinal ischemia by elevation of intraocular pressure (IOP) above systolic blood pressure.

Proliferating microglia were identified after daily injections of BrdU, and selective cell labeling with the specific marker Iba1, 3 and 7 days after 30, 45 or 60 minutes of ischemia in both eyes. Microglia were identified and quantified by means of laser scanning microscopy on retinal slices.

Following ischemia retinal thickness was significantly reduced due to mechanical compression after elevated IOP, with the strongest effect observed 60 minutes after ischemia. In response to lesion, microglia relocated mainly into the ganglion cell layer and the plexiform layers. The microglia cell morphology mostly changed to a more amoeboid form in particular after 60 minutes ischemia. Seven days after ischemia, independent of duration, the fraction of BrdU+ Iba1+ microglia was significantly increased as compared to untreated animals. Interestingly, there was no further increase in microglia after 60 minutes as compared to 45 minutes. In the contralateral unlesioned eye, also an increased fraction of proliferating Iba1+ microglia was found 7 days after 30, 45, and 60 minutes ischemia as compared to untreated animals, with no further increase after 60 minutes as compared to 45 minutes. Numbers of proliferating microglia in the unlesioned eye were 5 fold lower as compared to the ipsilateral lesioned eye.

Results from this study show that microglia proliferation is partly dependent on the duration of ischemia, being significantly increased already after 30, but with no further increase between 45 and 60 minutes of ischemia. The observed microglia proliferative response after different ischemia durations corresponds to the dynamic of ganglion cell death after acute ischemia, as described in other studies. Interestingly, the ischemic lesion induced a proliferative microglial response in the contralateral eye which followed a time-course similar to changes observed in the injured eye, however, at a lower level. This is an important finding, since the model of retinal ischemia shares many similarities with global cerebral ischemia, a cause for stroke. Further research is needed to identify mechanisms involved in this immunological response in the unlesioned eye.

Cognition without myelin - auditory discrimination in shiverer mice

Livia de Hoz Garcia-Bellido, Klaus-Armin Nave¹

¹ Max Planck Institut for Experimental Medicine, Neurogenetics, Hermann-Rein-Str. 3, 37075 Goettingen, Germany

To study the role of myelin in cognition using animal models is a difficult task, as myelin deficits cause motor and sensory impairments that make behavioural tests difficult to interpret. These deficits are often paralleled by axonal degeneration, which further clouds the interpretation of the behavioural data. Shiverer mice are severely demyelinated in the central nervous system due to the lack of myelin basic protein (MBP), and while they have a motor phenotype they don't exhibit axonal degeneration. Here we tested shiverer mice auditory discriminative abilities with the aim to assess the effect of myelin on neuronal processing through both frequency and temporal coding.

Female MBP knockout and wild type mice were trained in a two-tone discrimination task. The training was performed in an Audiobox (TSE), a modified mouse cage where animals live while their behaviour is monitored automatically by means of a reporter transponder inserted into each mouse. Access to water was restricted to a specialized corner and required nose-poke. Visits to the specialized corner were accompanied with the presentation of a train of tone pips. One frequency (6 KHz) indicated "safe" visits, whereas the other frequency (12 KHz, 17% of the visits) indicated "conditioned" visits, during which nose-pokes were followed by an air-puff and no water was available.

Surprisingly shiverer mice learned to discriminate between the 2 frequencies and differed from the wild type controls only on the initial hours of discrimination learning. This initial deficit is likely caused by a higher anxiety level in the knockout group.

We conclude that shiverer mice were able to learn all aspects of a behavioural task in a way that is similar to that of wild type mice. Lack of compacted myelin in the CNS did not interfere with learning that required discrimination between 2 well separated frequencies, which are probably processed by means of segregated fibre pathways. Further analysis of the mutant's capacity to perform also temporal discrimination will help us elucidate whether axonal function is impaired in unmyelinated tracks and whether the speed of information processing is a major determinant in task performance.

Poster Topic

T10: Aging and Developmental Disorders

- T10-1A** Morphological and biochemical phenotypes in a mouse model of Fragile X Syndrome
Viktoria G. Seidel, Peter C. Kind
- T10-2A** Living without synapse-associated CAM Neuroplastin affects steroid hormone levels, reproduction, and behavior.
Soumee Bhattacharya, Karl-Heinz Smalla, Philip W. Beesley, Eckart D. Gundelfinger, Dirk Montag
- T10-3A** Tissue Inhibitor of Matrix Metalloproteases-1 Impairs Reelin Processing in Experimental Epilepsy
Carola A. Haas, Stefanie Tinnes, Julia Ringwald
- T10-4A** Synergistic actions of different GABA uptake processes in the CA3 region of the immature rat hippocampus
Salim Sharopov, Rongqing Chen, Haiyan Sun, Sergei N. Kolbaev, Sergei Kirischuk, Heiko J. Luhmann, Werner Kilb
- T10-1B** Cellular phenotype of patient with immunodeficiency, centromeric instability, facial anomalies syndrome type 2 and homozygous mutations in ZBTB24
ETHIRAJ RAVINDRAN, Karoline Strehl, Lina Issa, Nadine Kraemer, Sebastian Fröhler, Katharina Eirich, Detlev Schindler, Wei Chen, Horst von Bernuth, Angela M. Kaindl
- T10-2B** Early Developmental Milestones, Isolation-induced Ultrasonic Calling, and Repetitive Behavior in *Shank1* Knockout Mice
A Özge Sungur, Rainer KW Schwarting, Markus Wöhr
- T10-3B** The stroke-induced microglial response in rats is age-dependent
Petra Henrich-Noack, Anne-Marie Miller, Marina Lynch
- T10-4B** Otoprotection by stimulation of cGMP cascade in a gerbil and rat animal model
Ksenia Varakina, Boris Müller, Mirko Jaumann, Marlies Knipper, Lukas Rüttiger
- T10-5B** Profilin1 is required for glial cell contact and radial migration of cerebellar granule neurons
Jan Kullmann, Alexander Neumeyer, Eckhard Friauf, Walter Witke, Marco Rust
- T10-1C** Impact of social experience on rat social approach behavior induced by 50-kHz ultrasonic vocalizations serving a pro-social communicative function
Dominik Seffer, Henrike Rippberger, Rainer K. W. Schwarting, Markus Wöhr

- T10-2C** Emission ratiometric multiphoton imaging of JC-1 fluorescence reveals mitochondrial alterations in a mouse model of Rett syndrome
Michael Müller, Dörthe Bebensee
- T10-3C** Normal social recognition but impaired object recognition in *Shank1* knockout mice
Magdalena CE Jochner, A Özge Sungur, Rainer KW Schwarting, Markus Wöhr
- T10-4C** Studying Gene-Environment interaction in aged mice overexpressing the schizophrenia susceptibility gene *Tcf4*
Dorota Badowska, Magdalena M. Brzózka, Peter Falkai, Moritz J. Rossner
- T10-5C** Trolox treatment improves cellular redox balance, hypoxia tolerance and synaptic plasticity in a mouse model of Rett syndrome
Oliwia Alicja Janc, Ursula Hirt, Emanuel Großer, Michael Müller
- T10-1D** Cognitive aging in the zebrafish (*Danio rerio*)
Tim Ruhl, Gerhard von der Emde
- T10-2D** The actin-depolymerizing protein cofilin is required for the polarization and proper positioning of cortical neurons
Xuejun Chai, Li Fan, Hong Shao, Shanting Zhao, Michael Frotscher
- T10-3D** A touch-screen cognitive testing method for an emerging primate brain aging model, the mouse lemur (*Microcebus murinus*)
Marine Joly, Sandra Ammersdoerfer, Mathias Craul, Daniel Schmidtke, Elke Zimmermann
- T10-4D** Loss of Parvalbumin Expressing Interneurons in Layer 2/3 of the human Epileptogenic Neocortex under various pathological conditions
Maximilian Sebastian Augustin, Silviya Ivanova, Catharina Donkels, Carola A. Haas, Stefan M. Hefft

Morphological and biochemical phenotypes in a mouse model of Fragile X Syndrome

Viktoria G. Seidel, Peter C. Kind¹

¹University of Edinburgh, Centre for Integrative Physiology/Patrick Wild Centre, George Square, EH8 9XD Edinburgh, United Kingdom

Fragile X Syndrome (FXS) is an X-linked genetic disease resulting in mental impairment and autistic behaviour and caused by the absence of the fragile X mental retardation protein (FMRP) due to transcriptional silencing of the FMR1 gene. As the disease can currently not be cured it is important to assess the native function of FMRP, the consequences of its loss and its role during development.

We previously reported that the critical period for the maturation of glutamate receptor signalling at thalamocortical synapses is delayed (1) and there is an increase in dendritic filopodia in layer IV of the primary somatosensory cortex (S1). We hypothesized that full genetic deletion of *Fmr1* in mice causes a general delay in synaptogenesis.

To test this hypothesis we use the *Fmr1* knockout mouse model (2) to study the loss of FMRP in hemizygous *Fmr1*^{-/y} males. We compared the morphological features of synapses in layers II-III and IV of S1 at P14 and P35 by electron microscopy. No differences were detected between genotypes (*Fmr1*^{-/y} and *Fmr1*^{+/y}) in synaptic density, PSD length, number of presynaptic vesicles/ μm of PSD or number of docked vesicles/ μm of PSD at either age. Furthermore, age-dependent changes in these parameters were not significantly different in the *Fmr1*^{-/y} mice compared to controls indicating a similar time-course of synaptic maturation. We next examined mRNA levels in S1 for a selection of synaptic proteins at P7 and P14 using qPCR. Again, no differences were detected between *Fmr1*^{-/y} and *Fmr1*^{+/y} at either age or in the magnitude of the age-dependent changes in expression. However, our lab recently reported a delay in somatosensory map formation, alterations in the morphology profile of dendrites and spines of layer IV neurons and a decrease in the synaptic levels of proteins involved in glutamate receptor signaling at times corresponding to the highest levels of FMRP expression (3).

Overall this suggests that the loss of FMRP does not cause a general developmental delay of synaptogenesis in primary somatosensory cortex in a mouse model of FXS but rather alterations in neuronal circuitry due to inaccurate timing of developmental processes.

Most recently, we have started to characterize the above described phenotypes in heterozygous *Fmr1*^{+/-} females. Very little research on the heterozygous deletion of *Fmr1* in mice has been reported. However, it has been shown that the audiogenic seizure phenotype is present in *Fmr1*^{-/y}, *Fmr1*^{-/-} and *Fmr1*^{+/-} alike but develops over a different time-course in each of the groups (4).

(1) Harlow, E. G. et al. (2010) *Neuron* 65, 385-98.

(2) Bakker, C. E. et al. (1994) *Cell* 78(1), 23-33.

(3) Till, S. M. et al. (2012) *Hum Mol Genet* 21(10), 2143-56.

(4) Musumeci, S. A. et al. (2000) *Epilepsia* 41(1), 19-23.

Living without synapse-associated CAM Neuroplastin affects steroid hormone levels, reproduction, and behavior.

Soumee Bhattacharya, Karl-Heinz Smalla², Philip W. Beesley⁴, Eckart D. Gundelfinger³, Dirk Montag¹

¹ Special Lab Neurogenetics,

²Special Laboratory for Molecular Biology Techniques,

³Department of Neurochemistry,

Leibniz Institute for Neurobiology, Brennekestr. 6, 39118 Magdeburg, Germany

⁴School of Biological Sciences, Royal Holloway University of London, Egham, Surrey TW20 0EX, UK

Neuroplastin is a single pass membrane glycoprotein belonging to the Ig-superfamily of cell adhesion molecules. It has two major isoforms Np55 and Np65 resulting from alternative splicing of the neuroplastin mRNA, and containing 2 and 3 immunoglobulin-like domains respectively. Np65 is a brain specific protein and is primarily enriched in the forebrain whereas Np55 is expressed in a wide range of tissues (Langnaese et al. 1998; Smalla et al. 2000). The recombinant ectodomain of Np65 and anti-Np65 antibodies interfere with the maintenance of long lasting LTP in vitro (Smalla et al. 2000; Empson et al. 2006). Recently, Np65 has been shown to colocalize with GABA_A receptor subtypes affecting receptor mobility and synaptic strength (Sarto-Jackson et al. 2012). Np55 induces synaptic Ca²⁺ responses in cultured hippocampal neurons through its interactions with the fibroblast growth factor receptor 1 (Owczarek et al. 2010). We generated neuroplastin-deficient mice and describe here the initial characterization of the phenotype resulting from lack of neuroplastin. Homozygous neuroplastin-deficient mice are viable but have a reduced life expectancy and display lower body weight and smaller size in comparison to their wild-type littermates. Altered levels of thyroid hormones or the major thyroid hormone transporter MCT8, and aberrant glucose metabolism or its dysregulation by insulin were experimentally excluded as potential causes for the reduced body weight. The anatomy and morphology of the Neuroplastin-deficient mice brain appear generally normal with all major structural entities and cell types present. Remarkable gender specific differences are observed with respect to reproduction. Neuroplastin-deficient males are unable to reproduce in contrast to their fertile female counterparts. Also, male mutants have a significantly higher serum level of the major stress hormone corticosterone whereas the female Neuroplastin-deficient mice show no differences when compared to age matched controls. After exposure to a dexamethasone suppression test, the male Neuroplastin-deficient mice are unable to suppress corticosterone levels, indicating severe dysregulation of the Hypothalamic Pituitary Adrenal (HPA) axis. Significantly lower amounts of glucocorticoid receptor observed in brain lysates of male Neuroplastin-deficient mice may account for the dysregulated HPA feedback loop. The behavior of Neuroplastin-deficient mice is affected in multiple ways progressively declining with age e.g. reduced motor-coordination capabilities are indicated by the rota-rod test, a less anxious or less light-avoiding behavior is displayed in the open field and light-dark-avoidance tests, associative learning measured in a two-way active avoidance paradigm is strongly reduced, and sensory motor gating is severely compromised revealed by the lack of prepulse inhibition of the acoustic startle response.

Despite its role at the synapse and for the balance between excitatory and inhibitory transmission, Neuroplastin abnormalities have not been identified as causal for a human disease or neurological disorder. Our results show that lack of Neuroplastin severely affects male reproduction, energy metabolism, HPA axis regulation, and several behavioral traits including learning. Potentially, dysfunction of neuroplastin compromises synaptic transmission and network function, thus, contributing to the

etiology of various metabolic and physiological alterations related to depression, schizophrenia, autism, or degeneration.

E.D.G, K-H.S., and D.M. were supported by grants from the Deutsche Forschungsgemeinschaft (SFB426; SFB779, GRK1167, GU 230/6-1, SM38/8-1), the COST action ECMNet, the Federal State of Saxony-Anhalt and the "European Regional Development Fund" (ERDF 2007-2013), and the Center for Dynamic Systems at the Otto-von-Guericke University Magdeburg.

Tissue Inhibitor of Matrix Metalloproteases-1 Impairs Reelin Processing in Experimental Epilepsy

Carola A. Haas, Stefanie Tinnes¹, Julia Ringwald¹

¹University of Freiburg, Exp. Epilepsy Research, Breisacher Str. 64, 79106 Freiburg, Germany

The extracellular matrix protein Reelin is an important regulator of neuronal migration and positioning in the developing and mature brain. Reelin is synthesized and secreted by Cajal-Retzius cells and GABAergic interneurons and its function depends on proteolytic cleavage after secretion. Lack of Reelin causes severe disturbances in cerebral layering such as the reeler phenotype and granule cell dispersion (GCD) in temporal lobe epilepsy. We have recently shown that epileptic conditions not only decrease Reelin levels, but also impair extracellular processing of Reelin by inhibition of matrix metalloprotease (MMP) activity. As a consequence, uncleaved Reelin accumulates in the extracellular matrix as a functionally inactive form and thereby contributes to the development of GCD (Tinnes et al., FASEB J 25, 2011).

In the present study, we used organotypic hippocampal slice cultures (OHC) to investigate the exact mechanism of MMP inhibition. When epileptic conditions were mimicked by KA treatment of OHC, we found significantly increased levels of tissue inhibitor of metalloproteases 1 (TIMP-1) levels in tissue extracts and supernatants indicating enhanced TIMP-1 synthesis and secretion upon hyperexcitation. TIMPs are endogenous inhibitors known to control MMP activity. Moreover we found that KA treatment strongly enhanced TIMP-1 immunolabeling in hippocampal neurons. Application of TIMP-1 alone was sufficient to inhibit proteolytic processing of Reelin and to induce a significant widening of the granule cell layer as observed after KA treatment. In contrast, by functional inhibition of TIMP-1 we could prevent the impairment of Reelin cleavage induced by KA, indicating that an increase in TIMP-1 expression is involved in impaired Reelin processing under epileptic conditions. In summary, we present evidence that epileptiform activity inhibits MMP activity by up-regulation of endogenous TIMP-1 which in turn leads to extracellular accumulation of uncleaved Reelin and to GCD.

(Supported by the DFG, SFB TR3).

Synergistic actions of different GABA uptake processes in the CA3 region of the immature rat hippocampus

Salim Sharopov, Rongqing Chen¹, Haiyan Sun¹, Sergei N. Kolbaev¹, Sergei Kirischuk¹, Heiko J. Luhmann¹, Werner Kilb¹

¹Medical University of the Johannes Gutenberg University Mainz, Institute of Physiology and Pathophysiology, Duesbergweg 6, D-55128 Mainz, Germany

GABA is a main inhibitory neurotransmitter in the adult nervous system, which mediates depolarising membrane responses in the immature nervous system. In accordance with the excitatory and inhibitory (via shunting) effects mediated by depolarising GABAergic responses, both pro- and anticonvulsive actions of GABAergic agonists have been reported, with a contribution of synaptic and extrasynaptic receptors. GABA transporters (GATs) are important elements of the GABAergic system. They decrease GABA levels after synaptic release and regulate the GABA concentration in the extrasynaptic compartment. Different types of GATs are already expressed in the immature CNS, but their diffuse cellular expression pattern is rather distinct from the mainly cell-type specific expression pattern in the adult CNS. In order to investigate the question to which extend different GATs contribute to the regulation of neuronal excitability, we examined the effects of subtype specific GAT inhibitors on epileptiform discharges in hippocampal slices of immature (postnatal day 4-7) rats using field potential recordings in the stratum radiatum of CA3 and whole-cell patch-clamp recordings of CA3 pyramidal cells.

The whole-cell patch-clamp recording revealed that the GAT1 inhibitor NO-711 (10 μ M) had no significant effect on the decay of isolated GABAergic postsynaptic currents, while their decay was significantly prolonged by $37\pm 12\%$ ($n=13$) in the presence of the GAT-2/3 inhibitor SNAP-5114 (40 μ M). Both substances had no significant effect on the holding currents, suggesting that they did not increase the extracellular GABA concentration. The field potential recordings revealed that repetitive 4-AP/low-Mg²⁺ induced epileptiform discharges were completely abolished by the GABA agonist muscimol (2-3 μ M), in accordance with an anticonvulsive GABA effect already in the immature CNS. However, application of 100 μ M GABA only slightly attenuated the occurrence of epileptiform discharges by $4\pm 2\%$ ($n=24$), suggesting that active GABA uptake reduced the effective GABA concentration in this interface preparation. Application of the GAT1 inhibitor tiagabine (30 μ M) had no effect on the occurrence of epileptiform discharges, but slightly increases the anticonvulsive effect of 100 μ M GABA to $11\pm 3\%$ ($n=19$). Application of the GAT2/3 inhibitor SNAP-5114 (40 μ M) affected neither the occurrence of epileptiform activity nor the anticonvulsive effect of GABA. In contrast, the coapplication of 30 μ M tiagabine and 40 μ M SNAP-5114 significantly attenuated epileptiform discharges by $45\pm 9\%$ ($n=16$). After inhibition of both GAT1 and GAT2/3 the application of 100 μ M GABA nearly abolished epileptiform activity.

In summary, these results indicate that in the immature hippocampus both GAT1 and GAT2/3 are functionally expressed. GAT1 can completely compensate a functional impairment of GAT2/3, while GAT2/3 can almost fully compensate the impairment of GAT1 function. In addition, our study suggests that the functional role of the different GAT subclasses is less restricted in the immature hippocampus, in accordance with the diffuse expression pattern of different GATs.

Cellular phenotype of patient with immunodeficiency, centromeric instability, facial anomalies syndrome type 2 and homozygous mutations in ZBTB24

ETHIRAJ RAVINDRAN, Karoline Strehl³, Lina Issa^{1,2}, Nadine Kraemer^{1,2}, Sebastian Fröhler⁴, Katharina Eirich⁵, Detlev Schindler⁵, Wei Chen⁴, Horst von Bernuth³, Angela M. Kaindl^{1,2}

¹Charite Universität-Medizin, Berlin, Institute of Cell and Neurobiology, Philippstrasse 12, 10115 Berlin, Germany

²Department of Pediatric Neurology, Charité – Universitätsmedizin Berlin.

³Department of Pediatric Immunology. Charité – Universitätsmedizin Berlin.

⁴Berlin Institute for Medical Systems Biology, Max-Delbrueck-Center for Molecular Medicine, Berlin.

⁵Institute of Human Genetics, University Würzburg.

The immunodeficiency, centromeric instability, facial anomalies (ICF) syndrome is an autosomal recessive disease presenting with immunodeficiency secondary to hypo- or agamma-globulinemia, developmental delay, and facial anomalies. Mutations in the ZBTB24 gene were first described as the genetic cause of ICF type 2 in 2011, and so far 11 families or individual patients carrying mutations in this gene have been identified. Centromeric instability is the cytogenetic hallmark of the disorder, which results from targeted chromosomal rearrangements related to a genomic methylation defect. Here we describe a further patient with this rare disease and, for the first time, the cellular phenotype in ICF2.

Early Developmental Milestones, Isolation-induced Ultrasonic Calling, and Repetitive Behavior in ***Shank1*** Knockout Mice

A Özge Sungur, Rainer KW Schwarting¹, Markus Wöhr¹

¹Experimental and Physiological Psychology, Philipps-University of Marburg, 35032 Marburg, Germany

Autism is a neurodevelopmental disorder with a strong genetic component. The three diagnostic symptoms include 1) abnormal reciprocal social interactions, 2) qualitative impairments in communication, and 3) stereotypies and repetitive patterns of behavior with restricted interests. Candidate genes for autism include the SHANK family of synaptic scaffolding proteins within the postsynaptic density (PSD). Along with *SHANK2* and *SHANK3*, mutations in *SHANK1* have been detected in several autistic individuals (Sato et al., Am J Hum Genet, 2012). *Shank1* null mutant mice exhibit altered PSD protein composition, with smaller, thinner PSDs and reduced size of dendritic spines, which correlated with weaker synaptic transmission (Hung et al., J Neurosci, 2008).

To test the hypothesis that a mutation in *SHANK1* contributes to the symptoms of autism, *Shank1*^{-/-}, *Shank1*^{+/-}, and *Shank1*^{+/+} mice were evaluated for behavioral phenotypes with relevance to autism. Here, we focus on communication deficits and repetitive behavior, as well as the early developmental milestones.

Shank1^{-/-} and *Shank1*^{+/+} mice (background: C57/B6 x 129Sv/Jae) were obtained from MIT (M. Sheng) and bred at a heterozygous background. For isolation-induced ultrasonic vocalization (USV), different litters were tested on postnatal day (PND) 3, 6, 9, or 12. To induce pup USV, mice were isolated from mother and litter for 10 min at room temperature. After measuring USV, developmental milestones, namely body temperature, body weight, surface righting, and vertical screen holding were assessed. For all genotypes, call rate exhibited an inverted U-shape pattern through the different PNDs, as typically observed. However, for *Shank1*^{-/-} pups this pattern was not as pronounced, and they emitted fewer USVs in comparison to *Shank1*^{+/+} and *Shank1*^{+/-} littermates. Thereby we showed that the fewer USVs emitted by *Shank1*^{-/-} pups are not due to a developmental delay, yet this decrement is likely to be attributed to the mutation of *Shank1* per se. In general *Shank1*^{-/-} pups had lower body weight, and minor deficits in vertical screen holding and surface righting. Body temperature did not differ between genotypes.

To measure repetitive behavior, a marble burying test was performed. Mice at 5-6 months of age were tested on three consecutive days with and without a social component, provided by using the bedding from a novel conspecific or clean bedding, respectively. Mice were tested in a cage with 20 marbles on the bedding, for 30 min. The number of marbles buried, locomotor activity, digging, self-grooming, and rearing behaviors were assessed. *Shank1*^{-/-} and *Shank1*^{+/-} mice showed lower locomotor activity and rearing behavior as compared to littermate controls. The numbers of marbles buried were reduced in *Shank1*^{-/-} and *Shank1*^{+/-} irrespective of the social context, which can be associated with the decreased locomotor activity. Genotypes did not differ in digging and self-grooming behaviors, with the exception of heterozygous animals having slightly higher self-grooming behavior.

Taken together, the present study confirms and extends previous findings (Wöhr et al., PLoS One, 2011; Silverman et al., Brain Res, 2011), showing that the deletion of *Shank1* leads to communication deficits, without affecting repetitive behavior.

The stroke-induced microglial response in rats is age-dependent

Petra Henrich-Noack, Anne-Marie Miller², Marina Lynch²

¹Otto-von-Guericke University, Inst. of Medical Psychology, Leipziger Str. 44, 39120 Magdeburg, Germany

²Trinity College Institute of Neuroscience, College Green, Dublin, Ireland

Stroke has a high prevalence in the elderly population. Many protocols for basic research in the ischaemia field, however, do not reflect this fact and the use of young rodents dominates. The current study was therefore performed in order to compare the post-stroke pathophysiology in young and aged rats.

We induced focal ischaemia by injecting stereotactically endothelin-1 into the brain of young and aged Wistar rats under isoflurane narcosis. Seven days after the occlusion, rats were anaesthetised again and decapitated. The brains were quickly removed, frozen and stored in the -80°C freezer until further processing. The brains were then sliced on a cryotome and Nissl stained after systematic sampling. The infarct area in slices was measured and calculations revealed no difference in the infarct volumes between young and aged rats. Adjacent slices were used for immunohistochemical staining of OX6, a marker of microglial activation, and quantification of this parameter revealed a significant increase in OX6 staining in aged animals as compared to young rats.

Although it seems that stroke does not lead to an increase in infarct volume in aged animals, as evaluated by standard histology, a more detailed analysis revealed that the pathophysiology may be different. Our results suggest that microglial activation, and therefore the inflammatory response, is significantly increased in old rodents. This is an important finding and may indicate that treatment of stroke patients may need to be adjusted depending on age.

Otoprotection by stimulation of cGMP cascade in a gerbil and rat animal model

Ksenia Varakina, Boris Müller¹, Mirko Jaumann¹, Marlies Knipper¹, Lukas Rüttiger¹

¹Tübingen hearing research center, Molecular Physiology of hearing, Elfriede-Aulhorn-Strasse 5, 72076 Tübingen, Germany

Recent findings indicate that also reversible hearing loss, when characterised by temporary threshold shifts, can be connected with slow degeneration of auditory nerve fibres (AN) and progressive hearing loss (Kujawa and Liberman, 2009), even if the damage initially would not become apparent in conventional clinical threshold testing. For acute persistent hearing loss after temporary noise exposure, we could recently show that the deterioration of inner hair cell (IHC) synapses following noise exposure can be overcome by the modulation of the cGMP signalling cascade (Jaumann et al., 2012). Whether the stimulation of cGMP cascade is also protective for slowly progression hearing loss with age is unclear.

The current project aims to highlight the molecular and physiological basis of presbycusis and to find the mechanism of deterioration of auditory fibre and IHC synapse deterioration.

To study presbycusis we investigate whether stimulation of cGMP signaling cascade is protective in situations of progressive hearing loss and auditory nerve fiber degeneration following mild noise exposure. In a rat and gerbil animal model (Rüttiger et al., 2007) functional hearing measurements were performed before and up to 8 weeks after exposure to TTS-inducing noise. An aged and young experimental group of animals were treated with cGMP cascade modulating drug or vehicle as control. Additionally, a group of animals was held in enriched environment conditions (with extended physical and sensory stimulation). Morphology of hair cells and neurons was analyzed by the presence of pre- and postsynaptic molecular markers. The results will help to identify compounds with otoprotective effect for presbycusis that could be a promising candidate for preventive therapy of age-related hearing loss in humans.

This work is supported by the grant G54_Rüttiger of Action on Hearing Loss society of The Royal National Institute for Deaf People, London, UK. The cGMP cascade modulating drug was kindly provided by Bayer Pharma AG.

Profilin1 is required for glial cell contact and radial migration of cerebellar granule neurons

Jan Kullmann, Alexander Neumeier², Eckhard Friauf³, Walter Witke^{4,5}, Marco Rust^{1,5}

¹Neurobiology/Neurophysiology Group, TU Kaiserslautern, Germany; ²General Zoology Group, TU Kaiserslautern, Germany; ³Animal Physiology Group, TU Kaiserslautern, Germany; ⁴Institute of Genetics, University of Bonn, Germany; ⁵Mouse Biology Unit, European Molecular Biology Laboratory, Monterotondo, Italy

Migration of neurons along radial glial cells is essential for the lamination of cortical structures in higher vertebrates. Cerebellar granule neurons (CGN) exploit fibers of Bergmann glia (BG) for radial migration from the external granule cell layer to their destination in the internal granule cell layer. Cell-cell contacts of CGN to BG play a pivotal role in this process, however little is known about the molecular mechanisms that control CGN-BG interaction. Here we demonstrate that profilin1 activity in CGN and BG is crucial for glial cell binding and radial migration. Genetic ablation of profilin1 in mouse brain leads to cerebellar hypoplasia, aberrant organization of cerebellar cortex layers and ectopic CGN. Moreover profilin1 mutants display a progressive degeneration of Purkinje cells and locomotor deficits. While profilin1 is critical for radial migration and glial cell binding of CGN, proliferation of neuronal progenitors, tangential migration of CGN and BG organization is independent of profilin1 function. The results in mice and the mapping of developmental neuropathologies to the chromosomal region of PFN1 suggest that profilin1 might have a similar function in humans.

Impact of social experience on rat social approach behavior induced by 50-kHz ultrasonic vocalizations serving a pro-social communicative function

Dominik Seffer, Henrike Rippberger¹, Rainer K. W. Schwarting¹, Markus Wöhr¹

¹Philipps-University of Marburg, Experimental and Physiological Psychology, Marburg, Germany

Rats are social animals in which rough-and-tumble play during adolescence has an important role for social development. Separation from conspecifics during this phase is known to impair social behavior. Post-weaning social isolation in rats is a widely used animal model to induce behavioral phenotypes and changes in neural development relevant to psychiatric disorders like schizophrenia (Fone & Porkess, 2008).

Ultrasonic vocalizations (USVs) are an important component of the rat's social behavioral repertoire. Rats emit distinct types of USVs, which serve as situation-dependent affective signals with important communicative functions. Low-frequency 22-kHz USVs occur in aversive situations such as fear-conditioning and lead to freezing behavior in the recipient, indicating an alarming function. In contrast, high-frequency 50-kHz USVs are produced in appetitive situations such as rough-and-tumble play and induce social approach behavior, supporting the notion that they serve as social contact calls (Wöhr & Schwarting, 2007).

Here, we tested whether social isolation impairs social approach behavior in response to playback of pro-social 50-kHz USVs and whether isolation-induced deficits depend on the time period of isolation during development. Male rats were housed in one of the following conditions: group housing, short-term isolation, i.e. 24 hours, or long-term isolation, i.e. 28 days. Rats were isolated either as weanlings with three weeks of age or as post-adolescent young adults with seven weeks of age, after going through rough-and-tumble play. As recent findings demonstrate that social deficits can be improved by peer intervention (Yang et al., 2011), we also tested for phenotypic rescue in this paradigm by exposing a subgroup of rats to one additional week of peer-rearing. Subsequently, all rats were tested for social approach behavior in response to 50-kHz USVs. As acoustic control stimuli served 22-kHz USVs and background noise.

While group-housed and short-term isolated rats displayed approach behavior in response to pro-social 50-kHz USVs, post-weaning long-term social isolation lead to a pronounced deficit, since rats displayed avoidance rather than approach behavior when exposed to 50-kHz USVs. Such deficits were not observed after post-adolescence long-term social isolation, indicating a critical period for social development during puberty. Importantly, approach deficits to 50-kHz USVs induced by post-weaning long-term isolation were reversed by peer-mediated re-socialization. This phenotypic rescue highlights the importance of social experience for affiliative behavior.

Emission ratiometric multiphoton imaging of JC-1 fluorescence reveals mitochondrial alterations in a mouse model of Rett syndrome

Michael Müller, Dörthe Bebensee¹

¹Universitätsmedizin Göttingen, Zentrum Physiologie und Pathophysiologie, Humboldtallee 23, D-37073 Göttingen, Germany

Rett syndrome is a neurodevelopmental disorder that is caused by *de novo* mutations in the X-chromosomal MECP2 gene which encodes for the transcriptional modulator methyl CpG binding protein 2 (MeCP2). Almost girls are being affected by Rett syndrome. First symptoms occur at an age of typically 6-18 months, when normal development is followed by loss of speech, cognitive impairment, epilepsy as well as severe breathing disturbances. Various indications suggest that also mitochondria are impaired in Rett syndrome. For example, ATP levels seem to be reduced in MeCP2-deficient brain tissue, the inner mitochondrial membrane is leaking protons, and parts of complex III of the respiratory chain are potentially dysregulated. Based on the increased oxidative damage detected in blood samples of Rett patients also oxidative stress has been proposed. In acute and cultured hippocampal slices we have already verified alterations in mitochondrial metabolism and mitochondrial membrane potential ($\Delta\Psi_m$) as well as an increased formation of reactive oxygen species. We therefore performed high-resolution multiphoton imaging to screen for changes in the morphology, mass and $\Delta\Psi_m$ of individual mitochondria in MeCP2-deficient mice (*Mecp2*^{-y}). As a marker for $\Delta\Psi_m$ we chose the ratiometric indicator JC-1. Depending on $\Delta\Psi_m$, JC-1 forms either green fluorescing monomers (depolarized mitochondria) or red fluorescing J-aggregates (hyperpolarized mitochondria). Accordingly, the ratio of red/green JC-1 fluorescence reports the $\Delta\Psi_m$ of individual mitochondria. In primary hippocampal cell cultures, individual mitochondria could be easily identified especially in flatly grown astrocytes. Deconvolution of image stacks followed by semi-automated analyses yielded the number of clearly identifiable mitochondria per cell, their morphological parameters and $\Delta\Psi_m$. Astrocytes obtained from *Mecp2*^{-y} hippocampus were found to contain a larger number of mitochondria. The size of the individual mitochondria, however, did not differ, which suggests an increased mitochondrial mass in *Mecp2*^{-y}. The $\Delta\Psi_m$ of WT and *Mecp2*^{-y} mitochondria did not differ significantly. Mitochondrial inhibition by cyanide or uncoupling by FCCP caused similar responses in *Mecp2*^{-y} and WT astrocytes. Incubation with the radical scavenger Trolox did not markedly affect the $\Delta\Psi_m$ or size of individual mitochondria. Yet it decreased the number of mitochondria per cell and abolished the genotypic differences observed earlier among WT and *Mecp2*^{-y} astrocytes. These studies show that on the level of individual organelles, mitochondria of *Mecp2*^{-y} hippocampus are more numerous. This increase in mitochondrial mass may contribute to the earlier observed genotypic differences in cellular redox homeostasis and the more oxidizing conditions in FAD/NADH ratio found in acute and/or organotypic slices from *Mecp2*^{-y} hippocampus. Trolox treatment, which is known to counteract oxidative stress and an accumulation of reactive oxygen species, abolishes the difference in mitochondrial density among WT and *Mecp2*^{-y} hippocampus. Adverse effects of Trolox treatment on the function of mitochondria were not observed.

Supported by the DFG (CMPB) and the International Rett Syndrome Foundation (IRSF).

Normal social recognition but impaired object recognition in ***Shank1*** knockout mice

Magdalena CE Jochner, A Özge Sungur¹, Rainer KW Schwarting¹, Markus Wöhr¹

¹ Experimental and Physiological Psychology, Philipps-University of Marburg, Gutenbergstr. 18, 35032 Marburg, Germany

SHANK1 has been identified as a candidate gene for autism spectrum disorder (ASD), among other members of the *SHANK* gene family (Sato et al., Am J Hum Genet, 2012). *Shank1* null mutant mice exhibit altered protein composition of the postsynaptic density of glutamatergic neurons and manifest ASD-related behaviors, namely communication deficits (Wöhr et al., PloS One, 2011) and an aberrant cognitive pattern, including impairment of contextual fear conditioning, normal cued fear conditioning, enhancement of spatial learning and impaired long-term retention of spatial memory (Hung et al., J Neurosci, 2008), in the absence of social deficits (Silverman et al., Brain Res, 2011). As ASD-relevant social behaviors have not yet been fully examined in *Shank1* null mutant mice and to contribute to a better understanding of the behavioral consequences of *SHANK1* mutations, we sought to investigate social approach behavior and social memory, as well as non-social memory in juvenile and adult *Shank1* null mutant (-/-), heterozygous (+/-) and wildtype mice (+/+).

Shank1 -/- and *Shank1* +/+ mice (background: C57/B6J x 129Sv/Jae) were obtained from MIT (M. Sheng) for heterozygous breeding. N = 76 mice (26 -/-, 28 +/- and 22 +/+), were tested at postnatal day 23-39. Social approach behavior was tested in a three-chambered box by exposing the previously isolated subject to an unfamiliar conspecific (age- and sex-matched C57/B6J mice constrained in a wired cage) in one side chamber, and a novel object (empty wired cage) in the other side chamber for a 10 min trial. After a 30 min delay, the object was replaced by a novel conspecific to test social memory in a second 10 min trial. To test object memory, subjects were familiarized with two identical objects during the first 10 min trial. After a 30 min delay, one of the familiar objects was replaced by a novel object and the subject underwent a second 10 min trial. Each subject received a 30 min habituation session 24 h before testing and underwent social and non-social testing on two consecutive days in balanced order. Approach behavior was scored when sniffing in proximity to the social stimuli or objects occurred.

Shank1 -/-, *Shank1* +/- and *Shank1* +/+ showed a preference for the social stimulus over the non-social stimulus in the social approach test, indicating normal social approach behavior in all three genotypes tested. In the social recognition test, all genotypes preferred to approach the novel over the familiar conspecific. Thus, subjects were able to discriminate between two animals after a 30 min delay period irrespective of genotype. In contrast, genotypes differed in their ability to distinguish between objects after the same length of delay: *Shank1* +/+ and *Shank1* +/- mice displayed normal object recognition by showing more approach towards the novel than the familiar object. *Shank1* -/- mice, on the other hand, showed no preference for the novel object in the object recognition test, indicating an impaired object memory.

The present findings are in line with data obtained in animal models and human studies showing that *SHANK1* mutations have relatively minor effects on social behavior as compared to *SHANK2* and *SHANK3* mutations. *SHANK1* mutations, however, lead to an aberrant cognitive pattern. It appears possible that mutations in the different members of the *SHANK* gene family are associated with distinct ASD-related behavioral symptoms.

Studying Gene-Environment interaction in aged mice overexpressing the schizophrenia susceptibility gene *Tcf4*

Dorota Badowska, Magdalena M. Brzózka^{1,2}, Peter Falkai², Moritz J. Rossner¹

¹Max-Planck-Institute of Experimental Medicine, Department of Neurogenetics, Hermann-Rein-Str. 3, 37075 Göttingen , Germany

²Ludwig-Maximilian-University Munich, Department of Psychiatry, Nussbaumstr. 7, 80336 München, Germany

BACKGROUND

The human TCF4 gene encodes a bHLH transcription factor and has been identified in multiple Genome Wide Association Studies (GWAS) as a novel schizophrenia (SZ) susceptibility gene (Steffanson, *et al.*, 2009, Li *et al.* 2010, Steinberg *et al.* 2011, Ripke, *et al.* 2011). *Tcf4* plays an important role in brain development and in learning and memory in adult mice. A transgenic mouse model overexpressing *Tcf4* in the adult forebrain (*Tcf4*tg) revealed cognitive and impairment of sensorimotor gating (Brzozka *et al.*, 2010) which resembles phenotypes frequently observed in schizophrenic patients.

It is generally accepted that the risk of schizophrenia is caused by interactions of genetic and environmental factors (GxE). Therefore, various environmental factors may either enhance or protect against disease outbreak in subjects carrying gene variants conferring an increased risk. Social stress as well as urbanization seems to enhance the risk to develop SZ while physical activity and social integration appears to be protective (Pajonk *et al.* 2010). Ageing might be another risk factor for some symptoms of SZ since it might contribute particularly to the cognitive decline seen in schizophrenic patients and unaffected individuals.

In this study we analyzed behavioral phenotype of aged *Tcf4*tg mice in a battery of behavioral tests monitoring cognitive and social behaviors to address aging as additional risk factor and its interaction with different housing conditions.

METHODS

Four weeks old *Tcf4*tg mice and their wild-type littermates were housed in enriched environment (EE) or upon social isolation rearing (IR) until they reached one year of age. EE is known to improve cognition and may help to overcome stress, while SH mimics social isolation often observed in schizophrenic patients. One year old animals were subjected to behavioral tests addressing the basic behavior and cognitive abilities (such as Morris water maze and fear conditioning).

RESULTS

Aged *Tcf4*tg mice show decreased freezing in contextual fear conditioning compared to the control mice when housed in IR. There are, however, no significant differences between genotypes in EE. In the Morris water maze in reversal learning phase single housed *Tcf4*tg mice learn the position of the hidden platform slower than the controls.

DISCUSSION

Aged *Tcf4*tg mice exhibit reduced fear memory and impaired flexibility in spatial learning. Manifestation of these potentially schizophrenia-relevant behaviors depends on the housing conditions. Social isolation worsens the phenotype of *Tcf4*tg mice and enrichment rescues it. However, ageing alone does not seem to synergistically contribute as a risk factor to the cognitive deficits observed in this animal model.

Trolox treatment improves cellular redox balance, hypoxia tolerance and synaptic plasticity in a mouse model of Rett syndrome

Oliwia Alicja Janc, Ursula Hirt¹, Emanuel Großer¹, Michael Müller¹

¹Institut für Physiologie und Pathophysiologie, Neuro- und Sinnesphysiologie, Humboldtallee 23, 37073 Göttingen, Germany

Rett syndrome is a neurodevelopmental disorder that arises from spontaneous mutations in the X-chromosomal MECP2 gene, which encodes for the transcriptional modulator methyl CpG binding protein 2 (MeCP2). Rett syndrome affects almost exclusively girls. An initially normal development for the first 6-18 month is followed by severe cognitive impairment, loss of speech, epilepsy, and life-threatening breathing disturbances giving rise to intermittent systemic hypoxia. Also mitochondrial function seems to be affected. It has been reported that a subunit of complex III of the mitochondrial respiratory chain is among the potentially dysregulated genes, the inner mitochondrial membrane is leaking protons, and brain ATP levels seem to be reduced. Furthermore, blood samples of Rett patients reveal increased oxidative damage. Therefore, we have performed various optical assays to rate mitochondrial function and cellular redox balance. In acute hippocampal slices of a mouse model of Rett syndrome (*Mecp2*^{-/-}) we detected an increased baseline ratio of FAD/NADH autofluorescence, which indicates a shift to more oxidized conditions. Also, a less intense increase of rhodamine 123 fluorescence in response to mitochondrial uncoupling suggests that *Mecp2*^{-/-} mitochondria are polarized less intensely. Interestingly, the mitochondrial alterations already emerge after the first postnatal week. Taking advantage of the optical redox-sensitive indicator roGFP1, we performed quantitative analyzes of the cytosolic redox status. These assays confirmed more oxidized baseline conditions in *Mecp2*^{-/-} slices as well as a more vulnerable redox-balance in response to oxidative challenge or mitochondrial inhibition. The primary cause seems to be an increased mitochondrial but not extramitochondrial formation of reactive oxygen species. Treatment of hippocampal slices with the radical scavenger Trolox - a water soluble vitamin E derivative - decreased the redox baseline of *Mecp2*^{-/-} slices to wildtype levels, and the exaggerated responses to oxidative challenge were dampened. Furthermore, electrophysiological recordings confirmed that this treatment attenuated the increased hypoxia susceptibility of adult *Mecp2*^{-/-} slices. It also noticeably improved synaptic long-term plasticity without affecting neuronal excitability or basal synaptic function. Adverse effects of Trolox-treatment on the mitochondrial metabolism or mitochondrial membrane potentials can also be excluded. The function of several receptors and ion-channels is crucially modulated by redox changes. Therefore, the oxidative burden as well as the more vulnerable redox balance detected in MeCP2-deficient neuronal networks clearly contribute to the neuronal hyperexcitability and diminished synaptic plasticity in Rett syndrome. We have verified that Trolox successfully improves cellular redox balance, attenuates the hypoxia susceptibility and reinstates synaptic long-term plasticity. These findings identify radical scavengers as very promising compounds for the treatment of various aspects of neuronal dysfunction in Rett syndrome.

Supported by the DFG (CMPB) and the International Rett Syndrome Foundation (IRSF).

Cognitive aging in the zebrafish (*Danio rerio*)

Tim Ruhl, Gerhard von der Emde²

¹University of Bonn, Institute of Zoology - Neuroethology, Endenicher Allee 11-13, 53115 Bonn, Germany

The characteristics of cognitive aging are intensively investigated since age-related impairments became a growing medical and social problem. In this field of research, animal models are needed to study the complex biological processes taking place in the aging brain. Recently the zebrafish (*Danio rerio*) was recognized as a potential model organism for the research on aging. Due to several advantages, the zebrafish is one of the most important model organisms in developmental biology, genetics and becomes increasingly important in behavioral studies as well. For the analysis of age-related cognitive decline in zebrafish we used different behavioral approaches and tested performances of wild-types of two different age groups (1 year and 2 years old).

(A) In a two-alternative choice paradigm, animals were taught to discriminate between two colors, i.e. to avoid one color and approach the other one. Fish learned to associate different colors either with a reward or a mild punishment. Learning was indicated by a decrease of the time needed for a decision and by an increase in the number of correct choices. (B) In another experiment the fishes' spatial cognition was investigated. Animals were released in an open-field maze and trained to use an ego- and allocentric strategy to find a certain spot containing food. Learning was indicated by a decrease in time and length of the swimming path until finding the reward. (C) For examination of anxiety-like behaviors, we used an escape response set-up, in which fish were confronted with an approaching black bar. Numbers of escape responses were counted and percentage of fear reactions was calculated.

We could identify age related decline of cognitive functions in the spatial memory test, but not in the associative color discrimination task. In the open-field maze, younger fish learned a strategy to find the food much faster than older fish. In contrast in the color discrimination test, both age groups showed learning behavior on a similar level.

The actin-depolymerizing protein cofilin is required for the polarization and proper positioning of cortical neurons

Xuejun Chai, Li Fan³, Hong Shao³, Shanting Zhao¹, Michael Frotscher¹

¹University of Hamburg, UKE, ZMNH, Institute for Structural Neurobiology, Falkenried 94, 20251 Hamburg, Germany

²Department of Neuroanatomy, Institute of Anatomy and Cell Biology, University of Freiburg, Freiburg, Germany

³School of Life Sciences, Lanzhou University, Lanzhou, China

During brain development, cortical postmitotic neurons migrate from their birthplace, the ventricular zone, to their final destinations in the cortical plate, forming the 6-layered cortical structure. Migrating neurons always have a bipolar morphology with a long, thick leading process and a short, thin trailing process. This polarization is important for the proper, directed neuronal migration. The motility of migrating neurons is based on cytoskeletal dynamics that requires constant remodelling of the actin and microtubule cytoskeleton. Cofilin, an actin-depolymerizing protein, plays an essential role in enhancing actin-filament dynamics and reorganization by severing actin filaments. The activity of cofilin is reversibly regulated by phosphorylation and dephosphorylation at Ser3, with the phosphorylated form being inactive. Conditional knockout mice showed that loss of n-cofilin impaired radial neuronal migration, resulting in the lack of proper cortical lamination. To investigate the roles of n-cofilin and its phosphorylation at Serine3, we used in utero electroporation and transfected postmitotic neurons in the cerebral cortex of mouse embryos with different constructs of n-cofilin including knockdown of n-cofilin and point mutations at serine3. Our results showed that overexpression of n-cofilin, knockdown of n-cofilin and point mutations at Ser3 all induced a loss of polarization of migrating neurons and an impairment of neuronal migration.

(Supported by the DFG: FR 620-12/1)

A touch-screen cognitive testing method for an emerging primate brain aging model, the mouse lemur (*Microcebus murinus*)

Marine Joly, Sandra Ammersdoerfer¹, Mathias Craul¹, Daniel Schmidtke¹, Elke Zimmermann^{1,2}

¹University of Veterinary Medicine Hannover, Institute of Zoology, Buenteweg 17, 30559 Hannover, Germany

²Center for Systems Neuroscience, Hannover, Germany

Mouse lemurs are gerbil-sized strepsirrhine primates living in a harsh, seasonally challenging Malagasy forest environment. Previous field research in the forests of Madagascar provided first evidence for spatial memory and travel route planning comparable to monkeys and apes, despite of small brain size and lesser complex sociality. Lifespan in mouse lemurs is up to 8 years in the field and 15 years in captivity, thus much lesser than in any other primate. Comparable to humans during aging, some, but not all captive mouse lemurs display neuropathological signs of Alzheimer disease with the presence of A β -amyloid plaques and/or neurofibrillary tangles, the development of cerebral atrophy and behavioural deficiencies. Thus, mouse lemurs are discussed as a model for primate brain aging and AD-like deficiencies. To explore and embed the cognitive skills of mouse lemurs into the evolution of primate intelligence and to successfully use mouse lemurs as a primate brain aging model, standardized and human-comparable cognitive testing methods are needed by which cognitive skills can be linked to the underlying neurological correlates. The CANTAB test battery, developed 25 years ago by Cambridge University, is a well renowned set of cognitive tests which allows assessing the cognitive abilities of humans.

The aim of this project was to establish and evaluate a CANTAB comparable touch-screen test battery from CAMPDEN instruments for its use in the model mouse lemur. We adapted the test setting to the conditions of mouse lemurs and performed a pilot study with 10 male mouse lemurs of a young age cohort. Findings revealed for the first time that mouse lemurs could be trained successfully to use a touch-screen for getting a reward. Furthermore, in a visual pair-wise discrimination task, all subjects passed the different phases as successfully as humans and monkeys. More complex tasks, e.g. reaction tasks, paired-association tasks, numerical tasks, are currently explored.

Findings of this comparative approach will not only give first comparable insight into the cognitive skills and its deficiencies during aging in the model mouse lemur, and thereby to cognition in a previously fairly neglected group of primates, the strepsirrhines, they will also shed light on fundamental cognitive building blocks from which our own unique human-specific intelligence derived.

The research leading to these results has received funding from the European Community's 7th Framework Programme (FP7/2007-2013) under grant agreement n° 278486 acronym "Develage".

Loss of Parvalbumin Expressing Interneurons in Layer 2/3 of the human Epileptogenic Neocortex under various pathological conditions

Maximilian Sebastian Augustin, Silviya Ivanova¹, Catharina Donkels², Carola A. Haas², Stefan M. Hefft¹

¹Cellular Neurophysiology II, Department of Neurosurgery, Albert-Ludwigs-University of Freiburg

²Exp. Epilepsy Research, Department of Neurosurgery, Albert-Ludwigs-University of Freiburg

Parvalbumin expressing (PV+) interneurons are essential components of cortical networks and contribute to the generation of gamma oscillations. These GABAergic interneurons do also play an important role in common neuropathological diseases, like epilepsy. One of the most prominent hypothesis postulates, that a loss of PV+ interneurons may contribute to the generation of epileptic seizures (Sloviter RS. et al., 1987). However, a detailed quantification of PV+ interneurons in the human epileptogenic neocortex is not available yet. Therefore, our aim was to quantify the PV+ interneurons in layer 2/3 of the human epileptogenic, like focal cortical dysplasias (FCDs) and non – epileptogenic neocortex. The latter brain tissue was obtained during neurosurgical resections of cortical areas overlaying deep brain tumors. Thus, we investigated neocortical slices of 38 patients (21 suffering from epilepsy and 17 controls suffering from neuro-oncological lesions). In order to determine the number of PV+ interneurons, the neurosurgically resected brain tissue was stained with mono - or polyclonal antibodies directed against Parvalbumin and confocal images were taken in order to count cells within a defined grid of Regions of Interest (ROIs) according to a standardized protocol (Imaris 7.5). To compare the quantity of PV+ interneurons with the quantity of all GABAergic interneurons expressing GAD 65/67 (Glutamate – Decarboxylase, 65 and 67 kDa isoforms) and with the overall number of neurons in layer 2/3 of the human neocortex, we performed a staining with anti – GAD 65/67 and anti – Neuronal Nuclei (NeuN) primary antibodies, respectively. Furthermore, in order to assign the cortical layers correctly, especially in the cases of focal cortical dysplasias, we performed additional staining of layer specific antigens with a primary anti – Calretinin (CR) for layer 2 and an anti – SMI32 antibody as a marker for layer 3. We found an average number of 6.68 ± 0.55 PV+ interneurons per averaged ROI in epileptogenic tissue, representing a volume of 0.0045 mm^3 . In contrast, in control tissue we counted 12.41 ± 1.28 PV+ cells. This represents a loss of 46.17% of PV+ interneurons in layer 2/3 in epileptogenic tissue. However, we found no reduction of the total number of neurons in epileptogenic tissue as compared to control tissue. Furthermore, we divided the epileptogenic tissue into different subgroups according to the underlying neuropathology: tissue obtained from patients suffering from hippocampal sclerosis (HS), from patients suffering from focal cortical dysplasia type 1 (FCD1) or type 2 (FCD2) and patients suffering from dual pathology, FCD combined with HS (FCD - HS). There was no significant difference in the number of PV+ interneurons in FCD – HS (7.17 ± 1.15) compared to isolated FCD (5.68 ± 0.86 , type 1 and 2) or HS (7.69 ± 0.66) alone. In contrast, we found 5.14 ± 1.01 PV+ interneurons in FCD 2 tissue, representing a more severe loss of 58.58% as compared to control. Given that the overall number of neurons was not changed, there is a selective reduction of PV+ interneurons in layer 2/3 of human epileptogenic tissue.

Poster Topic

T11: Alzheimer's, Parkinson's and other Neurodegenerative Diseases

- T11-1A** The role of calpain in acute axonal degeneration in the rat optic nerve in vivo
Jiannan Zhang, Jan-Christoph Koch, Uwe Michel, Mathias Bähr, Paul Lingor
- T11-2A** Sirtuin 2 deletion protects against MPTP-induced toxicity in a mouse model of Parkinsonism
Éva M. Szegő, Mostafa Semak, Tiago F Outeiro
- T11-3A** Inhibition of deubiquitinating enzymes by PR-619 causes the formation of protein aggregates in oligodendroglial cells and leads to the activation of the autophagic pathway
Veronika Seiberlich, Janika Borchert, Victoria Zhukareva, Christiane Richter-Landsberg
- T11-4A** Role of Growth Differentiation Factor -15 (GDF-15) in the 6-OHDA model of Parkinson's disease
Venissa Machado, Björn Spittau, Stefan J.-P. Haas, Andreas Schober, Andreas Wree, Kerstin Krieglstein, Klaus Unsicker
- T11-5A** Systematic comparison of the effects of alpha-synuclein mutations on oligomerization and aggregation
Diana Fernandes Lázaro, Eva Rodrigues, Patrícia Guerreiro, Ellen Gerhardt, Tiago Fleming Outeiro
- T11-6A** THE INTERPLAY BETWEEN ATP13A2 AND ALPHA-SYNUCLEIN IN PARKINSON'S DISEASE
Tomás Ribeiro da Silva Lopes da Fonseca, Silvio Rizzoli, Tiago Fleming Outeiro
- T11-7A** Rapamycin augments Apoptotic Cell Death caused by Proteasomal Inhibition in Oligodendroglial Cells
Monika Noack, Christiane Richter-Landsberg
- T11-8A** Deciphering the role of alpha-synuclein in the nucleus: insight into the molecular basis of synucleinopathies
Raquel Pinho, Lilach Soreq, Luis Fonseca, Kristina Gotovac, Markus Zweckstetter, Hermona Soreq, Fran Borovecki, Joaquim Ferreira, Cristina Rego, Tiago Outeiro
- T11-9A** Neuronal protection by GAPDH pseudogene P44 variant
Norbert Wendelin Seidler, Sara O. Mason, Christopher S. Theisen
- T11-10A** The expression of ProSAP/Shank proteins in development and aging in the healthy and diseased brain

- T11-11A** Intrastratial botulinum neurotoxin-A injection in rats is not cytotoxic - a histological and stereological analysis
Juliane Mehlan, Hans Brosig, Alexander Hawlitschka, Oliver Schmitt, Eilhard Mix, Andreas Wree
- T11-12A** Brain Tumor Microenvironment and Angiogenesis: xCT-derived Glutamate in the Limelight
Zheng Fan, Thomas Broggini, Stefan W Hock, Eric P Meyer, Marco Stamanoni, Michael Buchfelder, Ilker Eyüpoglu, Nic E Savaskan
- T11-1B** Characterization of human iPSC derived neurons of diseased and control donors
Stefanie Pfänder, Andreas Grabrucker, Stefan Liebau, Tobias Böckers
- T11-2B** Autoimmune mechanisms in the neurodegenerative Batten disease
Benedikt Grünewald, Holger Haselmann, Christian Werner, Antonia Post, Andreas Weishaupt, Sandy Popp, Angela Dreykluft, Claudia Sommer, Klaus Viktor Toyka, Christian Geis, Holger Haselmann, Christian Werner, Antonia Post, Andreas Weishaupt, Sandy Popp, Angela Dreykluft, Claudia Sommer, Klaus Viktor Toyka, Christian Geis
- T11-3B** Adult neurogenesis in the hippocampus of streptozotocin intracerebroventricularly treated rats – an animal model for sporadic Alzheimer's disease
Ping Sun, Ana Knezovic, Milena Parlak, Margeritha M. Lee, Qian Hua, Peter Riederer, Jürgen Deckert, Melita Salkovic-Petrisic, Angelika G. Schmitt
- T11-4B** Calcium dynamics in degenerating cone photoreceptors
Manoj Mohan Kulkarni, Emily Fan, Robin Kemmler, Timm Schubert, Bernd Wissinger, Thomas Euler, François Paquet-Durand
- T11-5B** Characterization of the mouse model *rd10* for Retinitis Pigmentosa (RP): a morphological and electrophysiological study
Sonia Biswas, Frank Müller
- T11-6B** Expression of glutaminyl cyclase and thyrotropin-releasing hormone in mouse hippocampus
Alexander Waniek, Maike Hartlage-Rübsamen, Astrid Kehlen, Hans-Ulrich Demuth, Steffen Roßner
- T11-7B** ROCK2 and GAP43 expression are altered in human Parkinson´s disease brains
Kim-Ann Saal, Lisa Barski, Lars Tönges, Sigrun Roeber, Hans Kretzschmar, Mathias Bähr, Paul Lingor
- T11-8B** Microglial cells in chronic epileptic rats exhibit subregion-specific activation, only partially associated with neuronal loss.
Ismeni E Papageorgiou, Andriani F Fetani, Andrea Lewen, Uwe Heinemann, Oliver Kann
- T11-9B** Spatial learning and short term memory in an APP/PS1 mouse model of Alzheimer's disease
Laura Psotta, Melanie Veit, Elmar Kirches, Volkmar Leßmann, Thomas Endres
- T11-10B** Rat brain oligodendrocytes take up a-synuclein from the environment and build up intracellular

inclusions in a time-dependent manner
Katharina Pukaß, Christiane Richter-Landsberg

- T11-11B** Septo-temporal modifications in adult hippocampal plasticity and neuronal integration in function of age and alpha-synuclein in a Parkinson's disease mouse model
Nada Ben Abdallah, Hanna Langemann, Jonathan Vogelsang, Juergen Winkler
- T11-12B** Role of JNK in autophagic cell death in the cingulate cortex in a KA-induced rat model of epilepsy
Alessandro Vercelli, Marta Tropiano, Giada Spigolon, Christophe Bonny
- T11-13B** Impact of proteasomal stress on the level of selected proteins of Bcl-2 family.
Peter Racay, Ivana Pilchova, Dusan Dobrota
- T11-1C** Effects of chronic subthalamic nucleus deep brain stimulation on the performance in the five choice serial reaction time task
Nadine Polascheck, Joachim K. Krauss, Kerstin Schwabe
- T11-2C** Neuronal cell death in inherited retinal degeneration is a surprisingly slow process
François Paquet-Durand, Ayse Sahaboglu, Olivier Paquet-Durand, Bernd Hitzmann, Per Ekstroem, Marius Ueffing
- T11-3C** Improvement and standardization of the pilocarpine model of temporal lobe epilepsy
Kathrin Töllner, Claudia Brandt, Wolfgang Löscher
- T11-4C** Beneficial effects of mitochondria-targeted cholesterol oximes in mice over-expressing alpha-synuclein
Franziska Richter, Sheila M. Fleming, Fuying Gao, Vincent Lemesre, Magali Michaud, Chunni Zhu, Giovanni Coppola, Thierry Bordet, Rebecca Pruss, Marie-Francoise Chesselet
- T11-5C** A Large Turkish Parkinson Pedigree with alpha-Synuclein Duplication: Blood Expression Biomarker Profile for Predictive Diagnostics
Georg Auburger, Suna Lahut, Özgür Ömür, Caroline Pirkevi, Hulya Tireli, Eva Herrmann, Nadine Brehm, Suzana Gispert, Nazli Basak
- T11-6C** Immortalized mouse hypothalamic GT1-7 neurons as cell culture model for glutaminyl cyclase function
Corinna Höfling, Maike Hartlage-Rübsamen, Ulrike Zeitschel, Holger Cynis, Hans-Ulrich Demuth, Steffen Roßner
- T11-7C** The EGF-like domain of Neuregulin 1 type III is liberated by ADAMs and BACE1
Michael Willem, Daniel Fleck, Christian Haass
- T11-8C** Impaired active avoidance memory in an animal model of Alzheimer's Disease, the APP/PS1 mouse
Carolin Rockahr, Michael Gruss, Laura Psotta, Thomas Endres, Volkmar Lessmann, Katharina Braun
- T11-9C** Validation of a rotenone-induced rat model of Parkinson's disease: behavioral and

electrophysiological measures

Christof v. Wrangel, Kerstin Schwabe, Joachim K. Krauss, Mesbah Alam

- T11-10C** ROCK inhibition in a cell culture model of α -synuclein aggregation
Hagen Lothar Walle, Lars Tatenhorst, Lars Tönges, Tiago Fleming Outeiro, Mathias Bähr, Paul Lingor
- T11-11C** Intracellular BDNF transport is impaired in mouse models of Alzheimer's disease
Bianca Seifert, Volkmar Leßmann, Tanja Brigadski
- T11-12C** Expression analysis of dopaminergic marker genes in tyrosine hydroxylase positive neurons in the striatum of TH-eGFP mice by laser microdissection
Martin Klietz, Candan Depboylu, Wei-Hua Chiu, Kazuto Kobayashi, Eberhard Weihe, Martin K.-H. Schäfer
- T11-13C** The NKCC1-inhibitor bumetanide does not enhance the effect of GABA- potentiating drugs on status epilepticus in rats.
Claudia Brandt, Kathrin Töllner, Gerda Brunhofer, Thomas Erker, Mario Gabriel, Peter W. Feit, Wolfgang Löscher
- T11-1D** The Interplay Between α -Synuclein and Rab GTPases: Insight into The Molecular Basis of Synucleinopathies
Sibylle Elisabeth Eisbach, Tiago Fleming Outeiro
- T11-2D** Generation and functional analysis of dopaminergic reprogramming factors for protein transduction
Sebastian Neumann, Naemi Treuter, Dennis Paliga, Koushik Chakrabarty, Rolf Heumann
- T11-3D** Effects of cyclosporine A on seizure thresholds in acute and chronic epilepsy models
Annelie Handreck, Deborah Annina Elger, Laura Gey, Manuela Gernert
- T11-4D** Evaluation and pharmacokinetic characterization of the radiotracer ^{123}I -FP-CIT using single photon emission computed tomography (SPECT) in a non-human primate model of Parkinson's disease
Enrique Garea-Rodríguez, Christina Schlumbohm, Boldizsár Czéh, Jessica König, Gunther Helms, Cornelia Heckmann, Birgit Meller, Johannes Meller, Eberhard Fuchs
- T11-5D** Electron Microscopy of Amyloid Fibre Aggregates induced by the Presence of SERF Protein
Gerd Leitinger, S. Fabio Falsone
- T11-6D** The role of apolipoproteins in cuprizone induced demyelination and subsequent remyelination
Birte Könnecke, Mathias Bähr, Mikael Simons
- T11-7D** H_2S production inhibition in an experimental model of seizures: EEG and behavioral effects
Dragan Hrnčić, Aleksandra Rasić - Marković, Veselinka Susić, Dragan Djurić, Olivera Stanojlović
- T11-8D** Electrical Imaging of Local Field Potentials and Single Unit Activity in Organotypic

Hippocampal Slices using a High-Density Multi-Transistor Array (Neurochip)
Lakshmi Channappa, Günther Zeck

- T11-9D** Characterization of Kir4.1 channel expression in Schwann cells of the sciatic nerve in a mouse model of metachromatic leukodystrophy
Cin-He Chang, Lihua Wang-Eckhardt, Matthias Eckhardt, Gerald Seifert, Volkmar Gieselmann, Christian Steinhäuser
- T11-10D** Mitochondrial dysfunction in a mouse model of Parkinson's disease
Julia Zerle, Florian Giesert, Martin Jastroch, Daniela Vogt-Weisenhorn, Wolfgang Wurst
- T11-11D** β -Synuclein aggregates and induces neurodegeneration in adult rat dopaminergic neurons in vivo
Grit Taschenberger, Johan Toloe, Yuliya Tereshchenko, Mathias Baehr, Sebastian Kuegler
- T11-12D** Differential alterations in neuronal network excitability and behavior in mice with cell type-specific expression of RNA-edited glycine receptor $\alpha 3L$
Jochen Christian Meier, Nicola Maggio, Gürsel Caliskan, Joanna Fedun, Ute Häussler, Sarah Kowalczyk, Luminita Stoenica, Ewa Chronowska, Birthe Smolinsky, Günter Schwarz, Tamar Dugladze, Gidi Rechavi, Uwe Heinemann, Carola A. Haas, Tengis Gloveli, Akos Kulik, Aline Winkelmann
- T11-13D** Computational characteristics of recurrent neural networks under the influence of Alzheimer's disease
Claudia Bachmann, Tom Tetzlaff, Susanne Kunkel, Philipp Bamberger, Abigail Morrison

The role of calpain in acute axonal degeneration in the rat optic nerve in vivo

Jiannan Zhang, Jan-Christoph Koch¹, Uwe Michel¹, Mathias Bähr¹, Paul Lingor¹

¹Department of Neurology, University Medicine, Georg-August University, 37075 Göttingen, Germany

Axonal degeneration plays a pivotal role in the pathogenesis of many neurodegenerative diseases. Increased calcium influx was shown to be one of the crucial initial events eventually leading to the fragmentation of the axon. The downstream mediators of calcium in axonal degeneration are, however, not known in detail. In the present study, we investigate the involvement of calpain, a calcium-activated cysteine protease, in acute axonal degeneration (AAD) in the rat optic nerve crush (ONC) model in vivo. Calpain activity at different time points after ONC was assessed by immunoblot and immunohistochemical analysis of spectrin breakdown products. The analysis showed that calpain activity was upregulated in a time dependent manner after crush in an area 400 μm proximal and distal from the lesion site corresponding to the region later affected by AAD. Several downstream targets of calpain including alpha-synuclein and collapsin response mediator protein-2 (CRMP-2) were analyzed with regards to their relevance in AAD. Using in vivo live imaging of the rat optic nerve we found that intravitreal injections of the calpain inhibitor calpeptin could attenuate AAD after ONC. In summary, we show that calpain is an important mediator and potential therapeutic target in axonal degeneration.

Sirtuin 2 deletion protects against MPTP-induced toxicity in a mouse model of Parkinsonism

Éva M. Szegő, Mostafa Semak¹, Tiago F Outeiro¹

¹University of Göttingen, Dept. Neurodegeneration, Waldweg 33, 37073 Göttingen, Germany

Parkinson's disease (PD) is an age-related movement disorder known associated with the loss of dopamine and dopaminergic neurons from the substantia nigra, and the accumulation of proteinaceous inclusions known as Lewy bodies throughout the entire brain. Several studies indicate that lifespan and health span might be extended through the manipulation of sirtuins, a family of seven NAD-dependent deacetylases (Sirt1-7) of which Sirt1 is the most studied. Sirt2 is a cytoplasmic protein known to deacetylate β -tubulin or p53. Sirt2 interacts also with 14-3-3, a protein that shares some structural similarities to α -synuclein. In addition, we previously showed that pharmacological inhibition of Sirt2 protects against α -synuclein toxicity in cell and fly models of PD. Here, we show, that mice lacking Sirt2 (Sirt2 KO) have a reduced number of dopaminergic neurons in the substantia nigra pars compacta, and reduced density of striatal tyrosine hydroxylase positive fibers. We found no difference in the number of Nissl-positive staining when compared to wild-type mice. In addition, we found that in Sirt2 KO mice there was decreased MPTP-induced loss of dopaminergic fibers from the striatum and that the remaining dopaminergic neurons in the substantia nigra are not sensitive to MPTP. Thus, our data suggests modulation of Sirt2 activity might be beneficial in a mouse model of parkinsonism, and demands further investigation as a possible strategy for therapeutic intervention in PD.

Inhibition of deubiquitinating enzymes by PR-619 causes the formation of protein aggregates in oligodendroglial cells and leads to the activation of the autophagic pathway

Veronika Seiberlich, Janika Borchert¹, Victoria Zhukareva², Christiane Richter-Landsberg¹

¹University of Oldenburg, molecular neurobiology/neurochemistry, Carl von Ossietzky Straße 9-11, 26129 Oldenburg, Germany

²LifeSensors, 271 Great Valley Parkway, Malvern PA 19355, USA

A number of neurodegenerative diseases are characterized by the presence of misfolded proteins and the formation of inclusion bodies in nerve and glia cells which can lead to cell loss due to apoptosis. These filamentous protein inclusions often contain ubiquitin, heat shock proteins (HSPs) and a specific cellular protein and are mostly localized at the microtubule organization centre (MTOC). The formation of inclusion bodies may be caused by the malfunction of protein degradative systems, e.g. the ubiquitin proteasome system (UPS) or/and macroautophagy. The autophagy pathway is the major degradation system of long-lived proteins and involves the engulfment of misfolded proteins and organelles like mitochondria by a double membrane, called autophagosome. The autophagosome fuses with lysosomes whose hydrolases degrade the contents. The autophagic pathway is discussed to be involved in the selective degradation of protein aggregates due to direct transport of autophagosomes and lysosomes to the MTOC. The UPS involves the reversible conjugation of ubiquitin to protein substrates which are targeted to the proteasome and degraded by the proteolytic unities. Deconjugation of ubiquitin from protein targets is required before degradation and performed by proteases called deubiquitinating proteins (DUBs). DUBs have a great range of functions in the cell including deconjugation and regeneration of ubiquitin and influence on signal transduction.

As we previously have shown, inhibition of DUBs by PR-619 (Lifesensors), an inhibitor of ubiquitin isopeptidases, causes the blockage of the UPS in oligodendroglial cells due to overwhelming it with ubiquitinated proteins and thus leads to the formation of protein aggregates near the MTOC, containing HSPs, ubiquitin, p62 and LC3. P62 is a protein which can bind to ubiquitin as well as to LC3, a protein present in autophagic phagophores and therefore used as a marker for autophagy. Hence, p62 is discussed to be the missing link between autophagy and the UPS. To further investigate whether DUB inhibition modulates the autophagic pathway in oligodendroglial cells, OLN-t40 cells, stably expressing the longest human tau isoform, and OLN-t40 cells transfected with GFP-LC3 were treated with PR-619. Autophagosome formation, abundance of LC3, p62, ubiquitin and GFP-LC3 were analyzed. Indirect immunofluorescence shows that PR-619 leads to protein aggregates around the MTOC which are positive for LC3, GFP and p62, and immunoblot analysis demonstrates an increase of these proteins and ubiquitinated polypeptides, while the autophagic flux was not disturbed. Furthermore, lysosomes accumulated at the MTOC, while mitochondria remained distributed throughout the cytoplasm. Treatment with Nocodazole revealed that intact microtubules are required for aggregate formation. In conclusion, disturbance of deubiquitination leads to the upregulation of the autophagic pathway, most likely as a defense mechanism, which however was not sufficient to combat protein aggregate formation.

Role of Growth Differentiation Factor -15 (GDF-15) in the 6-OHDA model of Parkinson's disease

Venissa Machado, Björn Spittau¹, Stefan J.-P. Haas⁴, Andreas Schober¹, Andreas Wree⁴, Kerstin Krieglstein^{1,3}, Klaus Unsicker¹

¹Institute of Anatomy and Cell Biology, Department of Molecular Embryology, Albertstr.17, 79104 Freiburg, Germany,

²Spemann Graduate School of Biology and Medicine (SGBM), University of Freiburg, 79104, Freiburg,

³FRIAS-Lifenet, University of Freiburg, 79104 Freiburg,

⁴Institute of Anatomy, University of Rostock, 18057, Rostock

GDF-15 is a novel distant member of the TGF- β cytokine superfamily. It is one of the most divergent members of this family and widely expressed in liver, lungs, heart, kidney and exocrine glands. At lower levels, GDF-15 mRNA and protein are ubiquitously found in the CNS; its site of highest expression being the choroid plexus, which secretes the protein into the CSF. GDF-15 has been shown to be significantly up-regulated in lesioned neurons and in activated microglia, suggesting that it may have roles in the lesioned CNS. Microglia - the resident immune cells of the CNS - are known to infiltrate sites of neuronal damage and inflammation. It has been observed that microglia also produce GDF-15, and hence, it is crucial to study the significance of this molecule in CNS lesion paradigms.

In this study, we used the unilateral 6-hydroxydopamine (6-OHDA) model of Parkinson's disease (PD) in mice. We examined the distribution and numbers of dopaminergic neurons and microglia in the substantia nigra and striatum in *Gdf-15*^{-/-} and wildtype mice at 2, 6.5 and 14 days post lesion. Furthermore, using quantitative RT-PCR, we investigated the expression profile of *Gdf-15* and several pro-inflammatory markers in 6-OHDA lesioned mice. We find that *Gdf-15* expression increased gradually from day 1 to peak at day 2 and decreased thereafter till day 14 post-lesion. *Gdf-15* upregulation on the lesion side was observed in both, the striatum as well as the substantia nigra, with a higher increase in the striatum.

The expression levels of the pro-inflammatory markers *iNos*, *Tnf-a* and *Il-6* revealed a higher increase in *Gdf-15*^{-/-} mice as compared to wildtype animals.

Taken together, our results suggest that GDF-15 upregulation in the 6-OHDA model of PD is involved in the regulation and termination of neuroinflammatory responses which is essential to reduce microglia-mediated neuronal damage in the nigrostriatal system.

Our work on GDF-15 is supported by grants from Deutsche Forschungsgemeinschaft.

Systematic comparison of the effects of alpha-synuclein mutations on oligomerization and aggregation

Diana Fernandes Lázaro, Eva Rodrigues¹, Patrícia Guerreiro^{1,2}, Ellen Gerhardt¹, Tiago Fleming Outeiro^{1,2,3}

¹University of Göttingen Medical School, Department of NeuroDegeneration and Restorative Research, Waldweg 33, 37073 Göttingen, Germany

²Cell and Molecular Neuroscience Unit, Instituto de Medicina Molecular, 04250 Lisboa, Portugal

³Instituto de Fisiologia, Faculdade de Medicina da Universidade de Lisboa, Av. Professor Egas Moniz, 1649-028 Lisboa, 04250 Portugal

Parkinson's disease (PD) is the second most common neurodegenerative disease, affecting approximately 1% of the population over 65 years of age. Although most PD cases are sporadic, mutations in specific genes have been linked to autosomal dominant or recessive forms of PD. Pathologically, PD is characterized by the progressive loss of dopaminergic neurons and the presence of Lewy Bodies (LBs) which are predominantly composed of fibrillar alpha-synuclein (aSyn). The aggregation progress of aSyn into LBs is a nucleation-dependent process that progresses from unfolded monomers to fibrils, through the formation oligomeric species. Recent evidence implicates oligomeric and prefibrillar oligomeric species as the more toxic aSyn species rather than aggregates themselves. However, little is still known about the molecular determinants of oligomerization and aggregation of aSyn in the cell.

For this purpose, we conducted a systematic comparison of the effect of familial aSyn mutations as well as artificial mutations that are known to interfere with the normal biology of the protein, using two different well established in vitro models to study oligomerization and aggregation of aSyn.

We found that although all familial mutants showed a similar propensity to oligomerize in living cells, they demonstrated different effects on inclusion formation. While the A30P mutant increased the percentage of transfected cells without inclusions, the E46K mutant decreased this percentage.

Interestingly, artificial proline mutants, designed to interfere with the helical structure of the N-terminal domain, showed increased propensity to form oligomeric species rather than inclusions.

The most prominent results were promoted by the lysine substitution mutants (E35K and E57K), which displayed a strong increase of oligomerization and altered the pattern of aggregation in comparison to wild type (WT) aSyn.

This comparative analysis will provide important insights into the molecular determinants involved in the misfolding and aggregation of aSyn, and may enable the development of novel therapeutic strategies for intervention in PD and other synucleinopathies.

THE INTERPLAY BETWEEN ATP13A2 AND ALPHA-SYNUCLEIN IN PARKINSON'S DISEASE

Tomás Ribeiro da Silva Lopes da Fonseca, Silvio Rizzoli³, Tiago Fleming Outeiro^{1,2}

¹UMG, Neurodegeneration and Restorative Research, Waldweg 33, 37073 Göttingen, Germany

²Cell and Molecular Neuroscience Unit, Instituto de Medicina Molecular, Portugal

³STED Microscopy of Synaptic Function, European Neuroscience Institute, DFG Research Center for Molecular Physiology of the Brain (CMPB)/Excellence Cluster 171

A common pathological hallmark among several neurodegenerative diseases is the aberrant protein-protein interactions that result in disruption of several essential cellular functions. Parkinson's disease (PD) is associated with the misfolding and aggregation of alpha-synuclein (a-syn), a pre-synaptic protein whose function is still unclear.

The cellular and biological interplay between all PD related proteins remains obscure, but recently ATP13A2 was described to be in the same network of a-syn as it was able to rescue a-syn related toxicity in yeast.

ATP13A2 is a lysosomal transmembrane P5 ATPase protein linked to Kufor-Rabek syndrome that was recently associated with familial cases of PD. Its biological role is uncertain but it is involved in the regulation of metal homeostasis, autophagy and mitochondrial regulation through mitophagy.

One of the described mutations in ATP13A2 consists in the duplication of residues 1632-1653 leading to a frameshift that results in the loss of the last six transmembrane domains of the protein (ATP13A2 Dup22).

Here, we investigated the interplay between a-syn and ATP13A2 in vitro, using triple (a-syn, synphilin-1 and ATP13A2s) or double (a-syn and ATP13A2s) transfections in H4 neuroglioma cell line. A wide range of effects, including aggregation of both wild type and mutant ATP13A2 were analyzed by immunocytochemistry. Aggregate characterization was done by STED microscopy in order to reveal the fine architecture of these a-syn species. ATP13A2 Dup22 enhanced a-syn aggregation, especially by increasing the number of cells with a high number of aggregates. Furthermore, co-expression of ATP13A2 and a-syn promoted the accumulation of cells with condensed nuclei and the formation of altered membrane structures.

Our studies open novel avenues for the study of the role of ATP13A2 on a-syn biology and may provide novel insight into the molecular basis of PD.

Rapamycin augments Apoptotic Cell Death caused by Proteasomal Inhibition in Oligodendroglial Cells

Monika Noack, Christiane Richter-Landsberg¹

¹University of Oldenburg, Department of Biology, Molecular Neurobiology, 26111 Oldenburg, Germany

A common feature underlying a variety of neurodegenerative disorders termed “tauopathies” is the formation of protein aggregates containing the microtubule-associated protein tau. In oligodendrocytes, the myelin forming cells of the CNS, tau fibrils accumulate as coiled bodies or glial cytoplasmic inclusions (GCI) that are co-localized with ubiquitin and heat shock proteins. Cellular mechanisms for degrading aberrant proteins include the ubiquitin-proteasome system (UPS) and autophagy, representing lysosome mediated degradative pathways. Inhibition of UPS has been demonstrated to promote the formation of GCI resulting in cellular toxicity and neurodegeneration. In this case autophagy may be the alternate route to clear the protein deposits. The present study was undertaken to elucidate whether upregulation of autophagy ameliorates tau aggregate formation and has cell survival promoting consequences against proteasomal inhibition in cultured rat brain oligodendrocytes and OLN-t40, an oligodendroglial cell line stably expressing the longest human tau isoform. For this purpose, cells were pre-incubated with rapamycin (Ra) to induce autophagy followed by proteasomal inhibition with MG-132. The induction of autophagy is monitored by increased LC3-II and decreased p62 protein levels. Aggregate formation was partially prevented indicated by reduced abundance of poly-ubiquitinated proteins and less compact aggregates as quantified in OLN-t40 cells. Proteasomal inhibition caused apoptotic cell death as monitored by caspase 3 activation and PARP cleavage, which was further augmented by pre-incubation with Ra. In conclusion, the stimulation of autophagy leads to clearance of tau protein aggregates in oligodendroglial cells, but does not exert cell survival effects.

Deciphering the role of alpha-synuclein in the nucleus: insight into the molecular basis of synucleinopathies

Raquel Pinho, Lilach Soreq⁴, Luis Fonseca⁵, Kristina Gotovac⁶, Markus Zweckstetter⁵, Hermona Soreq^{7,8}, Fran Borovecki⁶, Joaquim Ferreira⁹, Cristina Rego², Tiago Outeiro⁹

¹Universitat Medizin of Göttingen, Neurodegeneration and Restorative Research, Germany

²Center for Neuroscience and Cell Biology, Portugal

³University of Medicine of Porto, Portugal

⁴Department of Medical Neurobiology, Hebrew University-Hadassah Faculty of Medicine, Israel

⁵Research Group of Protein Structure Determination using NMR, MPI for biophysical chemistry, Max Planck Society, Germany

⁶Department for Functional Genomics, Center for Translational and Clinical Research, University of Zagreb School of Medicine, and University Hospital Center Zagreb, Croatia

⁷The Edmond and Lily Safra Center for Brain Sciences, The Hebrew University of Jerusalem, Israel

⁸Department of Biological Chemistry, The Life Sciences Institute, Israel

⁹Instituto de Medicina Molecular, Faculdade de Medicina da Universidade de Lisboa, Portugal

Alpha-synuclein (asyn), a common player in sporadic and familial forms of Parkinson's disease (PD), was first named for its localization both in the nucleus and presynaptic terminals. The nuclear localization has been controversial, despite several episodic reports. Growing evidence suggests that oxidative stress and some familial asyn mutations enhance its nuclear localization and promote neurotoxicity, possibly due to altered interactions with histones and modulation of gene expression. In both mouse models and human PD patients, transcriptional alterations have been reported. Here, we investigated the effects of asyn in the nucleus in terms of its cell biology and gene expression.

We started by comparing the gene expression patterns of two clinically distinct cohorts of PD patients, characterized by either slow or fast disease progression. We identified 147 genes with differential expression patterns between the two groups ($p < 0.01$). Validation by qPCR was performed for 5 selected genes in a subset of patients. We found different gene expression in genes whose function is linked to transcription regulation, ubiquitin-proteasome system, membrane trafficking and cytoskeleton dynamics. In parallel, to confirm the presence of asyn in the nucleus we performed in vitro studies, in cell culture models, and in mice. We verified that asyn is present in nuclear fractions from H4 cells overexpressing wild-type (wt) asyn and from the midbrain of transgenic A30P mice. Using immunohistochemistry we also demonstrated that asyn is present in the nucleus of cells from several brain regions during embryonic stages of development in mice and also, although to a lesser extent, in adult mice.

To further explore the interaction between asyn and DNA and identify novel promoter binding sites, we performed NMR experiments, genome-wide chromatin immunoprecipitation (ChIP)-sequencing and dual-luciferase assays. Our preliminary NMR results corroborate the hypothesis that asyn interacts with DNA and acts as a transcriptional modulator. ChIP-sequencing data shows that wt asyn can bind to several promoter regions involved in CNS functioning and development, such as NEDD4, CDH4 and SLC4A5. We confirmed that wt α -Syn overexpression resulted in a 27% increase of SLC4A5 promoter activity in dual-luciferase reporter assays.

In conclusion, our results provide novel insight into the effects of asyn in the nucleus, where it promotes transcriptional dysregulation by direct binding to DNA. Ultimately, our studies may open novel avenues for therapeutic intervention and for the development of novel biomarkers for PD.

Neuronal protection by GAPDH pseudogene P44 variant

Norbert Wendelin Seidler, Sara O. Mason¹, Christopher S. Theisen¹

¹Kansas City University of Medicine and Biosciences, Department of Biochemistry, 1750 Independence Ave, 64106 Kansas City, USA

GAPDH (glyceraldehyde 3-phosphate dehydrogenase) is a conserved glycolytic enzyme that binds diverse proteins, such as Siah during the process of apoptotic nuclear translocation. There is only one somatic GAPDH gene, but over 60 pseudogenes; the expression of these pseudogenes is nebulous, though there's evidence that the GAPDHP44 pseudogene generates a transcript. A single nucleotide polymorphism (SNP) in this pseudogene exhibits a beneficial allele in Alzheimer disease (Li et al., 2004). The objective of this study was to examine the P44 gene and to propose a mechanism for the putative protein and its impact in neuronal protection. We examined the sequences in the putative coding region of the human GAPDHP44 gene and the upstream genetic elements using a bioinformatics approach. We compared the amino acid sequences of the putative gene product (i.e. with and without SNP) with that of the parent GAPDH protein, using a program to predict naturally disordered regions. There is a TATA box 24 nt upstream from, and a Kozak sequence at, putative transcription and translation start sites, respectively. The upstream region also has sequences (7-16 nt) paralogous to those in parent gene introns; one shows homology to a known enhancer element. The resulting protein would contain 139 aa due to a stop codon, roughly the same size as the dinucleotide domain (151 aa) of the parent protein. The SNP is in a region (residues 80-120) that binds to the protein GOSPEL. We propose that the beneficial SNP may cause a glutamine to glutamate substitution, which causes a large increase in its tendency towards disorder. NMDA-stimulated neurons undergo GAPDH nitrosylation, Siah translocation, but can be rescued by GOSPEL binding to GAPDH. Our model suggests that the putative P44 protein may regulate GAPDH-GOSPEL interaction and the beneficial SNP may ameliorate AD.

The expression of ProSAP/Shank proteins in development and aging in the healthy and diseased brain

Resham Chhabra, Katharina Mangus¹, Tobias M. Boeckers², Andreas M. Grabrucker^{1,2}

¹ WG Molecular Analysis of Synaptopathies, Neurology Dept., Neurocenter of Ulm University, Ulm, Germany

² Institute of Anatomy and Cell Biology, Ulm University, Ulm Germany

Synaptic homeostasis is an essential phenomenon for normal functioning of the central nervous system (CNS) and alterations in synapse formation, maturation and plasticity are tightly controlled during development and aging. It is thus not surprising that an imbalance of the establishment and maintenance of synapses is an underlying factor for many synaptopathies including Alzheimer's disease (AD), the most common cause of dementia. AD is clinically characterized by gradual and global cognitive decline and an increased synaptic loss during aging can be considered as an example for an imbalance in synapse maintenance.

Various recent studies revealed that the proteins of the ProSAP/Shank family act as major scaffolding elements in the postsynaptic density (PSD) of excitatory synapses and the expression level of ProSAP2/Shank3 is able to influence synapse formation. ProSAP/Shank assembly within the PSD is Zn²⁺-dependent and Zn²⁺ might be a major factor in controlling synaptic homeostasis. Intriguingly, an imbalance in brain Zn²⁺ levels as well as ProSAP/Shank protein levels has been associated with a variety of neuropsychological and neurodegenerative disorders. For example, Zn²⁺-binding by A β leads to synaptic loss via dysregulation of ProSAP2/Shank3 scaffold in AD. Thus, the expression of ProSAP/Shank proteins during development and aging in a brain region- and isoform specific manner may be a major indicator of the condition of a brain under investigation.

Therefore, here, we performed *in vivo* studies on mouse models investigating the expression levels of ProSAP/Shank family members during development and aging in a brain region specific manner analyzing all ProSAP/Shank family members and their known isoforms. Moreover, since the expression of ProSAP/Shank proteins is tightly regulated by Zn²⁺, we analyzed the levels of zinc during aging. To this end, we performed protein biochemistry and immunohistochemistry as well as zinc staining using wildtype mice. Next, we investigate how this expression pattern is altered in various mouse models for brain disorders such as AD. Further based on our results, we currently develop novel strategies to influence observed alterations and induce the expression levels of ProSAP/Shank proteins as seen in healthy animals. To that end, we evaluate the use of nanoparticles targeting the CNS.

Taken together, this study will provide new insights into many synaptopathies such as AD and hopefully provide a basis for the evaluation and screening of substances to rescue observed pathologies.

Intrastriatal botulinum neurotoxin-A injection in rats is not cytotoxic - a histological and stereological analysis

Juliane Mehlan, Hans Brosig¹, Alexander Hawlitschka¹, Oliver Schmitt¹, Eilhard Mix²,
Andreas Wree¹

¹University of Rostock, Institute of Anatomy, Gertrudenstraße 9, 18055 Rostock, Germany

²University of Rostock, Department of Neurology, Gehlsheimer Straße 20, 18147 Rostock, Germany

Parkinson's disease (PD) is caused by progressive degeneration of dopaminergic neurons in the substantia nigra pars compacta (SNc), resulting in a deficiency of dopamine (DA) in the striatum. The DA deficiency leads to a cascade of functional changes in basal ganglia circuitry, especially to an increased release of acetylcholine by tonically active interneurons in the caudatus putamen complex (CPu).

Botulinum neurotoxin-A (BoNT-A) is a metalloproteinase that enters presynaptic terminals and blocks the release of ACh via the specific cleavage of the synaptosomal-associated protein of 25-kDa. Recently, we could show that intrastriatally applied BoNT-A at a dose of 1 ng reverses the apomorphine-induced rotation behaviour in the 6-OHDA-induced rat model of hemi-PD for more than 3 months. In addition, treatment of the rats with 2 ng BoNT-A restores the symmetric forepaw usage, which is disturbed by the 6-OHDA-lesion.

Furthermore, intrastriatal treatment with 0.1 – 2.0 ng BoNT-A in rats leads to striking morphologic changes in the CPu in form of multiple round axonal swellings that are immune reactive either for choline acetyltransferase (ChAT) or for tyrosine hydroxylase (TH) and which we tentatively named BoNT-induced varicosities (BiVs).

Here we investigated the long-term effect of the injection of 1 ng BoNT-A into the right CPu of Wistar rats on the number of ChAT-positive interneurons as well as on the number and the size of ChAT- and TH-positive BiVs in the CPu.

Brains were analyzed 2 weeks, 1 month as well as 3, 6, 9 and 12 months after BoNT-injection by immunohistochemical staining for ChAT and TH. Stereological examination was performed by application of a 3-axis motorized microscope (BX 51, Olympus) equipped with a microcater (MT12) and RGB camera (CX9000) in combination with StereoInvestigator (v8.0, MicroBrightField Bioscience).

For detection of possible inflammatory processes, stainings for markers of gliosis (glial fibrillary acidic protein, GFAP) and microglia (Iba1) were performed.

Significant differences in the number of ChAT-positive neurons between the right BoNT-A-treated CPu and the left untreated CPu were not detected at each time point of examination. The numeric density of the ChAT- and TH-positive BiVs in the CPu reached a maximum 3 months after BoNT-treatment and decreased afterwards, whereas the volume of the BiVs increased steadily throughout the whole time course of the experiment.

In brains of rats, which were killed two weeks and one month after intrastriatal application of 1 ng BoNT-A, immunohistochemical stainings for Iba1 and GFAP showed no enhanced immune reactivity for these markers of inflammatory processes, when the left (untreated) and right (BoNT-A treated) CPu were compared.

We conclude that intrastriatal BoNT-A application at doses up to 1 ng does not lead to neuronal cell loss or inflammatory reactions.

Brain Tumor Microenvironment and Angiogenesis: xCT-derived Glutamate in the Limelight

Zheng Fan, Thomas Broggini², Stefan W Hock¹, Eric P Meyer³, Marco Stampanoni⁴, Michael Buchfelder¹, Ilker Eyüpoglu¹, Nic E Savaskan¹

¹Department of Neurosurgery, University Medical School Erlangen, D-91054 Erlangen, Germany.

²Department of Neurosurgery, Charité Universitätsmedizin Berlin, Germany.

³Institute of Molecular Life Sciences, University of Zurich, Zurich, Switzerland.

⁴Institute of Biomedical Engineering, ETH and University of Zurich, Zurich, Switzerland.

Glutamate is a serum derived factor that promotes cell growth and proliferation in various tumors. In addition, glutamate also evokes neuronal cell death at high concentrations. A hallmark of human malignant brain tumors (i.e. gliomas) is their induction of peritumoral edema or brain swelling and subsequently neurodegeneration. A major factor contributing to glioma-induced cell death has recently been identified as glutamate. Although glutamate signaling at the receptor and its downstream effectors has been understood at the molecular level, it remained unclear how glutamate is exported into the tumor microenvironment. Surprisingly, system Xc- via xCT channel appeared to take center stage in this process, mediating glutamate secretion in exchange for cystine to the extracellular space. Here, we dissected glutamate and glutamate receptor signaling in gliomas demonstrating by pharmacological or genetic disruption that glutamate is not essential for proliferation. Hence, AMPA receptor signaling did not foster glioma proliferation in vitro. However, inhibiting xCT transporter or AMPA receptors in vivo mitigated brain swelling and peritumoral alterations. Moreover, the ability of glutamate to promote glioma progression was mediated contrariwise indirectly via tumor microenvironment modulation and angiogenesis. In particular, we shed light on the role of xCT in gliomas supporting the conceptual challenge that xCT disruption goes beyond cytotoxicity towards microenvironmental normalization. Thus, xCT takes center stage in forming the basis of a metabolic equilibration approach.

Characterization of human iPSC derived neurons of diseased and control donors

Stefanie Pfänder, Andreas Grabrucker^{1,2}, Stefan Liebau¹, Tobias Böckers¹

¹Ulm University, Institute for Anatomy and Cell Biology, Albert-Einstein-Allee 11, 89081 Ulm, Germany

²Ulm University, Neurocenter, Albert-Einstein-Allee 11, 89081 Ulm, Germany

The differentiation of progenitor cells into neurons that subsequently form synapses is a highly regulated process. Disturbances in these mechanisms are an underlying factor of many brain disorders. Synaptogenesis - the formation of cell-cell contacts with highly specialized pre- and postsynaptic compartments to ensure signal transduction in particular, is not static and can change due to a variety of factors. Thereby this synaptic plasticity enables processes like learning or memory.

ProSAP (Proline-rich synapse-associated protein)/Shank molecules are important scaffolding proteins in the postsynaptic compartment of excitatory synapses. They build platforms linking components of the postsynaptic signaling apparatus to the actin-based cytoskeleton through direct and indirect protein interactions. Thus, they build a framework for the formation of the postsynaptic density. Interestingly, two of the three ProSAP/Shank family members are targeted to and regulated at the PSD via their sterile alpha motif which is essential for protein assembly by binding to zinc ions.

An emerging role for ProSAP/Shank proteins in neurodegenerative diseases was first proposed when a deletion in the q13 region of chromosome 22, where the ProSAP2 gene is located, was identified as the main genetic cause for Phelan-McDermid Syndrome (PMS). This neurodegenerative disease is characterized by features of autism spectrum disorders along with hypotonia and mental retardation. Intriguingly, an association of autism spectrum disorders with zinc deficiency in children was already shown and imbalances in zinc homeostasis have been associated with multiple brain disorders. Thus, here, we investigate the effects of zinc supplementation and depletion on the differentiation and synaptogenesis of neurons differentiated from human stem cells. Moreover, we will use PMS patient derived stem cells to evaluate, if zinc supplementation could be a possible treatment strategy for PMS. In a first set of experiments we therefore evaluated expression of zinc homeostasis proteins of differentiated neurons from patient derived stem cells and control stem cells. In parallel synapse morphology and branching are examined microscopically. Thus, indeed, zinc seems to be an important factor in neuro- and synaptogenesis and future experiments will hopefully provide further evidences.

Autoimmune mechanisms in the neurodegenerative Batten disease

Benedikt Grünewald, Holger Haselmann¹, Christian Werner², Antonia Post³, Andreas Weishaupt², Sandy Popp³, Angela Dreykluft², Claudia Sommer², Klaus Viktor Toyka², Christian Geis^{1,2}, Holger Haselmann¹, Christian Werner², Antonia Post³, Andreas Weishaupt², Sandy Popp³, Angela Dreykluft², Claudia Sommer², Klaus Viktor Toyka², Christian Geis^{1,2}

¹ Hans Berger Department of Neurology, Jena University Hospital, Jena, Germany ²Department of Neurology, University Hospital Würzburg, Würzburg, Germany ³ Department of Psychiatry, University Hospital Würzburg, Würzburg, Germany

Batten disease (also juvenile neuronal ceroid lipofuscinosis, JNCL) caused by mutations in the *cln3*-gene is a neurodegenerative disease characterized by vision loss, motor and cognitive decline, ataxia, progressive seizures, psychiatric abnormalities, and death in the third or fourth decade of life. Beside the underlying neurodegenerative processes also autoimmune features may play a role in the disease course. Among others, the 65 kD isoform of glutamic acid decarboxylase (GAD65) is one of the major autoantigens. Autoantibodies against GAD65 are detected in patients as well as in mouse models for JNCL. Autoimmunity directed against GABAergic neurons might have a modulating effect on the disease course and may provide an explanation for certain aspects of JNCL, e.g. the selective loss of GABAergic interneurons.

A multidimensional approach was used to study whether these autoantibodies really have an major impact on the disease course in a murine knockout-model (*cln3*^{-/-}). We found age-dependent behavioral changes in *cln3*^{-/-} mice. These developed learning deficits, increased anxiety behavior, and motor coordination abnormalities, all of them consistent with diminished GABAergic inhibition in the respective CNS networks. We also found prominent depositions of autoantibodies within the brain structures responsible for the behavioral abnormalities in the *cln3*^{-/-}-mice. Further, using in-vivo and in-vitro electrophysiology, we found normal spinal synaptic transmission, but severe Purkinje cell dysfunction in acute cerebellar slice preparations when access of autoantibodies to the CNS was increased by opening of the blood brain barrier. GABAergic modulation in Purkinje cell synchronization was affected in a manner similar to findings with selective Purkinje cell GABA-A receptor deficiency during spontaneous firing and after parallel fiber stimulation. Thus, the observed severe ataxic behavior in *cln3*^{-/-} mice may result from defective GABAergic cerebellar inhibition mediated by autoantibodies.

Taken together we found behavioral and functional abnormalities in the *cln3*^{-/-} mice that might be influenced by the occurrence of autoantibodies preferentially targeting inhibitory neurons.

Adult neurogenesis in the hippocampus of streptozotocin intracerebroventricularly treated rats – an animal model for sporadic Alzheimer's disease

Ping Sun, Ana Knezovic², Milena Parlak¹, Margeritha M. Lee¹, Qian Hua³, Peter Riederer¹, Jürgen Deckert¹, Melita Salkovic-Petrisic², Angelika G. Schmitt¹

¹ Department of Psychiatry, Psychosomatics and Psychotherapy, University of Würzburg, Würzburg, Germany

² Department of Pharmacology and Croatian Institute for Brain Research, School of Medicine, University of Zagreb, Zagreb, Croatia

³ Scientific Research Center, School of Preclinical Medicine, Beijing University of Chinese Medicine, Beijing, China

The phenomenon of adult hippocampal neurogenesis (AN), the generation of functional neurons in the adult dentate gyrus of the hippocampus, has been shown to be active in humans. Therefore, it may provide a basis for neuronal replacement therapy in neurodegenerative diseases like Parkinson's disease, stroke, amyotrophic lateral sclerosis and Alzheimer's disease (AD). There is a big controversy in literature regarding the involvement of AN in AD etiopathology. Most AN studies have used transgenic mice with altered amyloid β precursor protein levels. But, these animal models relate more to the familial form of AD and not to the sporadic form of AD (sAD), which accounts for 95% of sufferers. We have investigated AN in streptozotocin intracerebroventricularly (STZ icv) treated rats, which exhibit cognitive deficits following STZ icv treatment, and are proposed recently as an animal model of sAD.

For our AN study, the sAD model rats were sacrificed 1 and 3 months after STZ icv treatment. The combination of BrdU incorporation with a survival time of approximately 4 weeks and its subsequent detection via immunohistochemistry have been included in this study. Additionally, usage of other antibodies recognizing different AN stages such as the proliferation marker MCM2 and the two markers for immature neurons NeuroD and DCX has allowed us to analyse AN thoroughly. For proper quantification we immunostained serial sections and used the Stereo Investigator software from MicroBrightField. As recent studies have pointed to different functions of the dorsal and ventral part of the hippocampus, we analysed them separately.

The results demonstrate that STZ icv treatment resulted in altered AN levels exclusively in the dorsal hippocampus, which has been reported to have a preferential role in certain forms of learning and memory, and not in the ventral hippocampus. In this region, the total number of both, NeuroD as well as DCX positive cells, were shown to be significantly decreased in rats 3 months after STZ icv injections compared to rats 3 months after the vehicle icv treatment. Interestingly, alteration of the number of NeuroD and DCX immunoreactive cells was not observed after one month STZ icv treatment. The quantification of BrdU and MCM2 positive cells is still in progress.

In summary, we could reveal impaired adult neurogenesis in the hippocampus of STZ icv treated rats, which possibly relates to cognitive deficits observed in this non-transgenic sAD animal model.

Calcium dynamics in degenerating cone photoreceptors

Manoj Mohan Kulkarni, Emily Fan³, Robin Kemmler¹, Timm Schubert^{1,2}, Bernd Wissinger¹, Thomas Euler^{1,2}, François Paquet-Durand¹

¹Centre for Integrative Neuroscience, ²Institute for Ophthalmic Research,

³Graduate School of Cellular & Molecular Neuroscience

Photoreceptor degeneration is a pathological state in which an inherited mutation leads to loss of photoreceptors and subsequently to blindness. Even though models of photoreceptor degeneration have been studied extensively and some players involved have been mapped, an exact pathway along which photoreceptor cell death proceeds has not been established to date. Previous studies demonstrated an accumulation of cGMP in outer segments of photoreceptors suggesting an elevation of intracellular Ca^{2+} via activation of CNG channels. Accordingly, a rise in Ca^{2+} -dependent, calpain-type proteolytic activity has been detected, which indirectly indicates a contribution of Ca^{2+} to photoreceptor cell death. Similarly, *rd1/CNG* channel double mutant animals illustrated a temporal delay and overall decrease of photoreceptor deterioration also suggesting an involvement of Ca^{2+} . To define a specific role of Ca^{2+} in photoreceptor degeneration, it is indispensable to monitor Ca^{2+} dynamics at the subcellular level in degenerating retina. To test this, we are using retinal degeneration lines, *rd1* and *cpfl1*, crossbred with TN-XL mice in which cones are labelled with a fluorescent ratio-metric Ca^{2+} biosensor (Wei et al., 2012). The *cpfl1* and *rd1* mice carry analogous mutations in the phosphodiesterase 6 gene, in cone and rod photoreceptors, respectively. Consequently, the *cpfl1* model is characterized by cone degeneration whereas *rd1* retina shows primary rod degeneration followed by secondary cone degeneration.

Immunohistochemical results of *cpfl1*/TN-XL animals displayed co-localisation of cone photoreceptors with TUNEL (a cell death marker) as well as cGMP, concomitant with cone degeneration. *rd1*/TN-XL animals also exhibited co-localisation of TUNEL with cone photoreceptors after post natal day (PN) 20 indicating secondary cone degeneration. In contrast, at PN20 co-localisation of cGMP with cone photoreceptors was not detected in *rd1*/TN-XL animals. Analysis of *wt*/TN-XL animals showed a cone density comparable to *wt*-animals until PN24. In parallel, we established an approach to measure Ca^{2+} levels in cone pedicles, using two-photon microscopy, in ex-vivo retinal slices of TN-XL crossbred animals. Preliminary results of Ca^{2+} measurement in *rd1*/TN-XL crossbreds exhibited a steady decline in Ca^{2+} resting level with age. On the other hand, *cpfl1*/TN-XL animals revealed higher Ca^{2+} resting level than *rd1*/TN-XL animals of comparable age.

Altogether, our results demonstrate that TN-XL animals crossbred into degeneration lines can be effectively utilized to study Ca^{2+} dynamics in dying cones. Further studies will be focused on the measurement of Ca^{2+} at different time points to test whether alterations in Ca^{2+} dynamics take place before or after degeneration onset.

Characterization of the mouse model *rd10* for Retinitis Pigmentosa (RP): a morphological and electrophysiological study

Sonia Biswas, Frank Müller¹

¹Institute of Complex System-4, Forschungszentrum Jülich, Cellular Biophysics, Wilhelm-Johnen-Straße, 52428 Jülich, Germany

The retina harbors the photoreceptors as well as a neuronal network that performs the first steps of information processing before the signals are relayed to the brain by the retinal output neurons, the retinal ganglion cells (RGCs). In different retinal diseases such as retinitis pigmentosa (RP), the photoreceptors degenerate over time but the cells in the retinal network, in particular the ganglion cells remain. This raises the possibility to employ prostheses to electrically stimulate the retinal network or the RGCs such that they can relay information to the visual centers in the brain. Among many animal models of RP, the most extensively characterized animal is the *rd1* (*Pde6b*^{rd1}) mouse. The more recently identified *Pde6b*^{rd10} (*rd10*) mouse which carries a mis-sense mutation in the same gene, has a later onset and slower rate of photoreceptor degeneration than the *rd1* mouse. The slower degenerative time course makes *rd10* a more appropriate model of human RP, and presents a broader window of opportunity to test therapies for photoreceptor rescue.

In the present study we used anatomical and electrophysiological techniques to reveal modifications in the inner retina after photoreceptor loss in the *rd10* mouse. We observed major changes both during and after photoreceptor degeneration. Changes include sprouting of horizontal cells, loss of rod bipolar cell dendrites, and progressive thinning and irregularities in the INL (Fig.1).

In vitro recordings using multielectrode arrays (MEA) revealed that the electrophysiological properties of *rd10* retinae differed significantly from those of normal retinae. In *rd10* retinae but not in wildtype retinae, we observed rhythmic bursts in the spontaneous spiking activity of retinal ganglion cells (RGCs) that were correlated with a slow wave component (SWC) of 4 - 5 Hz. In order to understand the origin of this SWC we applied various compounds to block ion channels or synaptic transmission. Our results show that the SWC of *rd10* mouse depends on the activation of glutamate receptors and, therefore, most likely on bipolar cell activity.

At present it is not known why the loss of photoreceptors leads to changes in the basal activity in the remaining retinal network. The rhythmic input to ganglion cells might interfere with the stimulation of retinal ganglion cells via microelectrode prostheses. Thus, the SWC should be further studied and fully characterized to find a strategy to overcome its effects on retinal physiology.

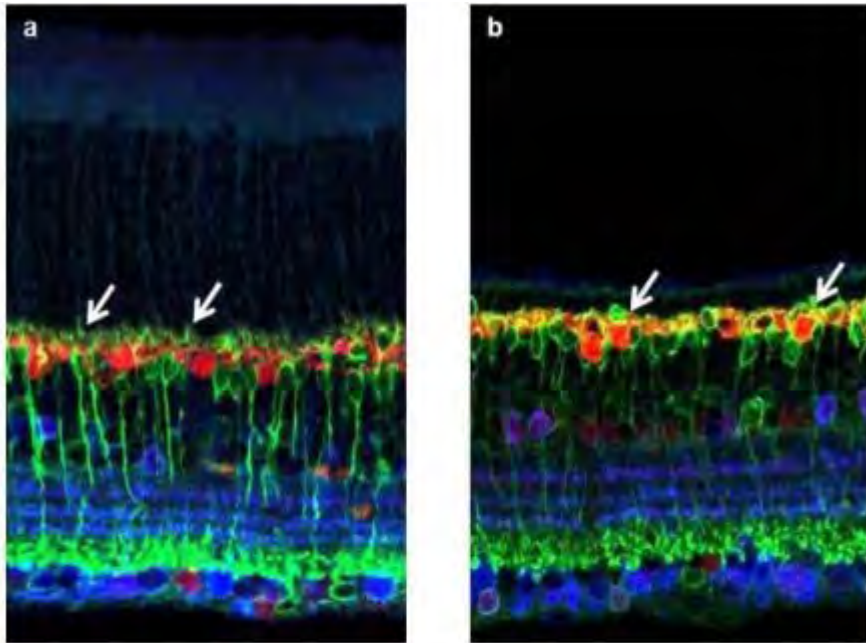

Fig. 1 a (wildtype), b (rd10): immunohistochemical staining of rod bipolar cells (PKC, green), horizontal cells (CabP, red) and amacrine cells (calretinin, blue). In rd10 mouse retina (P32) photoreceptors have disappeared and rod bipolar cell dendrites are strongly reduced (arrows in b), compared to the situation in wild type retina (arrows in a).

Expression of glutaminyl cyclase and thyrotropin-releasing hormone in mouse hippocampus

Alexander Waniek, Maïke Hartlage-Rübsamen¹, Astrid Kehlen², Hans-Ulrich Demuth²,
Steffen Roßner¹

¹University of Leipzig, Paul-Flechsig Institute for Brain Research, Jahnallee 59, 04109 Leipzig, Germany

²Probiodrug AG, Weinbergweg 22, 06120 Halle (Saale), Germany

The brains of Alzheimer's disease (AD) patients are characterized by the formation of high molecular weight aggregates of A β peptides. Recently, A β peptide variants with an N-terminal truncation and subsequent pyroglutamate (pE) modification have been identified and shown to be more prone to aggregation, resistant to proteolysis and highly neurotoxic. The pathogenic pE modification of A β is catalyzed by glutaminyl cyclase (QC) and it was shown that pharmacological inhibition of QC ameliorates A β deposition and gliosis and improves learning and memory in APP transgenic mouse models (1).

In the literature, constitutive QC expression has been reported in the hypothalamus, where amongst others thyrotropin-releasing hormone (TRH) is known to be a physiological QC substrate. Recently, we demonstrated distinct QC expression by hippocampal interneurons of mice. However, in contrast to the hypothalamus, we currently lack knowledge about the physiological role of QC in the hippocampus.

Besides the humoral role of TRH in the hypothalamic-pituitary-thyroid axis, hippocampal TRH expression is of particular interest because it was shown to be neuroprotective against excitotoxicity and A β neurotoxicity (2, 3). Thus, we turned our attention to TRH as a possible QC substrate in this brain region important for learning and memory.

Using immunohistochemistry we detected TRH-positive neurons in the hilus (polymorphic layer) of the dentate gyrus, in stratum radiatum, stratum oriens and stratum lacunosum-moleculare of the mouse hippocampus. Interestingly, this distribution is similar to the QC staining pattern in the hippocampus. The double immunofluorescence experiments confirmed the co-localization of QC and TRH in hippocampal interneurons of mice.

This co-localization of TRH and QC in the hippocampus would provide an explanation for the significant QC expression in one of the most affected brain regions in AD.

In human APP-transgenic tg2576 mice we recently described co-localization of QC and pE-A β in amyloid deposits. Therefore we analyzed these AD model mice with regard to expression of QC, TRH and the receptor TRH-R1 at different ages by immunohistochemistry and qPCR experiments.

With respect to the pathogenesis of AD, it is conceivable that QC might be up-regulated in the hippocampus in order to generate more of the neuroprotective peptide TRH. In contrast to its purpose this increased QC activity might concomitantly lead to exceeding formation of pE-A β and thereby to an aggravation of AD pathology.

The fact that both QC (by modifying A β and its substrate TRH (by neuroprotection against A β neurotoxicity) are involved in AD makes it a very interesting topic for further research.

1) Schilling S et al, Nature Medicine, 2008, 14, 1106–1111

2) Veronesi MC et al, Brain Research, 2007, 1128, 79–85

3) Jaworska-Feil J et al, Neuropeptides, 2010, 44, 495-508

ROCK2 and GAP43 expression are altered in human Parkinson's disease brains

Kim-Ann Saal, Lisa Barski¹, Lars Tönges¹, Sigrun Roeber³, Hans Kretzschmar³,
Mathias Bähr^{1,2}, Paul Lingor^{1,2}

¹Department of Neurology, University Medicine Göttingen, Göttingen, Germany

²Center for Molecular Physiology of the Brain (CMPB), University Medicine Göttingen, Göttingen, Germany

³Center for Neuropathology and Prion Research (ZNP) at the Ludwig-Maximilians-University, Munich, Germany

Parkinson's disease (PD) is a neurodegenerative disease characterized by neuronal cell death mostly in the substantia nigra pars compacta (SNpc), but the pathogenic molecular mechanisms still remain unclear. Our previous studies suggest that Rho-associated kinase (ROCK) affects neuronal survival in common PD animal models.

To investigate the relationship between nigral neurodegeneration, dopaminergic regeneration failure and regeneration associated proteins in PD, we performed an immunohistochemical analysis of human brain sections of PD patients with high (HLB) and low Lewy body load (LLB), age-matched (AC) and young controls (YC). We examined sections of five individuals per group and evaluated the extent of dopaminergic cell loss in the SNpc and axonal degeneration in the nigrostriatal projections. This was set in relation to the expression of ROCK2 and growth associated protein 43 (GAP43).

Our data confirm that ROCK2 and GAP43 show a specific distribution in the human midbrain and striatum. In an overview analysis ROCK2 expression was less pronounced in the SNpc and the putamen than in the surrounding fiber tracts, while the expression of GAP43 shows a converse pattern. Specifically, the expression of GAP43 was markedly increased in the SNpc of LLB and HLB groups. In contrast, ROCK2 expression was lower in TH+ neurons of the SNpc and adjacent parenchyma in PD patients, whereas controls show a higher ROCK2 expression in TH+ cells.

The decreased ROCK2 expression in the SNpc in PD patients could be due to progressive metabolic impairment in TH+ neurons in the course of the disease or represents a response to degeneration, facilitating compensatory sprouting of dopaminergic fibers. On the other hand, increased expression of GAP43 in the SNpc could reflect a compensatory regenerative response to dopaminergic degeneration. We thus firstly confirm the presence of ROCK2 in human brain sections and suggest that inhibition of ROCK could represent a therapeutic strategy in PD by stimulation of the regenerative response.

Microglial cells in chronic epileptic rats exhibit subregion-specific activation, only partially associated with neuronal loss.

Ismini E Papageorgiou, Andriani F Fetani², Andrea Lewen¹, Uwe Heinemann², Oliver Kann¹

¹Institute of Physiology and Pathophysiology, University of Heidelberg, Im Neuenheimer Feld 326, D-69120 Heidelberg, Germany

²Institute of Neurophysiology, Charité Universitätsmedizin, Oudenarderstrasse 16, D-13347 Berlin, Germany

INTRODUCTION: Human and experimental Medial Temporal Lobe Epilepsy (MTLE) has been recently correlated with functional changes in the brain's resident macrophage population, known as microglial cells. Microglial activation has been proposed both as cause and consequence of acute seizures. However, little is known about the role of microglial cells during the chronic phase of epilepsy, which is associated with perpetuating damage and hippocampal neuronal loss in both human and animal models. In the current study we investigate the hypothesis whether microglial cells are chronically activated in experimental MTLE, and whether activation coincides with neuronal loss.

METHODS: Microglial activation was assessed at the chronic stage of pilocarpine-induced experimental MTLE in Wistar rats, by calcium-binding protein Iba1 and surface glycoprotein CD11b immunohistochemistry with quantitative brightfield and confocal microscopy. The size of the microglial population in different hippocampal subregions was estimated with stereology, whereas morphometric changes (cell size and branching pattern) were quantified with NeuroLucida-based reconstructions.

RESULTS: Setting as activation criteria 1) the population size, 2) the somatic size and shape 3) the degree and pattern of ramification and 4) the surface expression of CD11b, we report that in control rats, Iba1-positive, highly ramified microglia are scatterly distributed, without significant differences in number, size and ramification pattern among different hippocampal subregions. By contrast, CD11b is rarely expressed in a small fraction of the Iba1(+) population. Using confocal microscopy, we categorized microglia into two phenotypes: Iba1(+)/CD11b(-) and Iba1(+)/CD11b(+), thus confirming that Iba1 is a universal microglial marker. An Iba1(-)/CD11b(+) phenotype was not observed.

In epileptic rats, Iba1(+) microglial cells exhibit signs of activation (somatic enlargement, restricted ramification and expression of CD11b) in a subregion-specific pattern. Somatic enlargement and restricted ramification dominates in the molecular layer of dentate gyrus, whereas CD11b expression is mostly evident in hilus. The high expression of CD11b in hilus is coherent with local neuronal loss. On the other hand, the evident morphometric changes in the molecular layer of dentate gyrus are not correlated with neuronal death.

CONCLUSIONS: With the current study we convey the message that microglial cells are activated at the chronic stage of experimental MTLE in a subregion-specific pattern, relevant to the local neuronal loss. However, different methods used for quantifying microglial activation should be cautiously interpreted as not necessarily convergent.

ACKNOWLEDGEMENTS: This work was supported by the DFG with the SFB TR3 transregional grant for Medial Temporal Lobe Epilepsies.

Spatial learning and short term memory in an APP/PS1 mouse model of Alzheimer's disease

Laura Psotta, Melanie Veit², Elmar Kirches², Volkmar Leßmann^{1,3}, Thomas Endres¹

¹Medical School, Otto-von-Guericke University, Institute of Physiology, Leipziger Str. 44, 39120 Magdeburg, Germany

²Institute of Neuropathology, Otto-von-Guericke University, Magdeburg, Germany

³Center of Behavioral Brain Sciences (CBBS), Magdeburg, Germany

Learning and memory processes are one of the first obvious abilities which are impaired in Alzheimer's disease (AD) patients. With ongoing progress of the disease these impairments become more and more severe and develop in a destructive manner. As one of the possible causes of the ongoing pathology of AD the increased occurrence of the cell toxic A β protein is discussed. This protein is cleaved from the amyloid precursor protein (APP) and can cause oxidative stress, neuroinflammation and neuronal cell death. The brain regions first affected by AD include the hippocampus, the enterorhinal cortex and basal cholinergic nuclei which project to the hippocampus. All these brain areas are required for memory formation. Beside the increased occurrence of A β protein it has been also shown that AD patients exhibit reduced levels of BDNF (brain-derived neurotrophic factor) in the brain and the blood serum. Since BDNF is an important mediator of synaptic plasticity and in addition possesses protective actions against A β -induced cell toxicity, alterations in BDNF protein might be an important mechanism in the development of AD pathology. In order to setup a mouse model to analyze the impact of BDNF on the development of AD pathology we first further characterized the cognitive abilities of an APP/PS1 mouse model that has been described to develop an AD-like pathology at middle ages (Radde et al., EMBO Rep. 2006). This mouse combines the KM670/671NL (Swedish) APP and the PS1-L166P mutations, found in familiar AD cases. Because of the age-dependent progress of Alzheimer's disease animals of different ages were tested in the novel object recognition (NOR) task and in the Morris water maze (MWM). In the NOR we did not observe any differences between APP/PS1 mice and WT littermates at any tested age, suggesting no impairments of short-term memory in these animals. In the water maze test we observed impaired spatial learning in APP/PS1 mice when they were 5 months of age or beyond. In addition, animals of this strain were also tested in the active avoidance task (see Poster of Rockahr et al.). At the moment we are quantifying the BDNF protein level in the hippocampus of the tested animals by using a sensitive BDNF-ELISA. Furthermore, also the amount of A β protein and several markers of oxidative stress were analyzed in the brains of these animals by using an A β -ELISA and immunohistological methods. Here, first results clearly showed a strong increase in A β protein in APP/PS1 mice. In conclusion, we could demonstrate an age-dependent decline in spatial learning starting at an intermediate age of the APP/PS1 mice, thus making it an ideal mouse model to study the onset and development of AD pathology. Currently we are analyzing whether the development of cognitive deficits in this mouse line is accompanied by alterations in the amount of A β , BDNF and markers for oxidative stress.

This work was supported by the SFB 779/B6 as well as by the federal state of Saxony-Anhalt and the "European Regional Development Fund" (ERDF 2007-2013), Vorhaben: Center for Behavioral Brain Sciences (CBBS).

Rat brain oligodendrocytes take up α -synuclein from the environment and build up intracellular inclusions in a time-dependent manner

Katharina Pukaß, Christiane Richter-Landsberg¹

¹University of Oldenburg, Department of Biology, Molecular Neurobiology, D-26111 Oldenburg, Germany

Multiple system atrophy (MSA) is a sporadic, progressive neurodegenerative disease. The pathological hallmarks of MSA are glial cytoplasmic inclusions (GCIs) originating in oligodendrocytes (ODCs), mainly consisting of fibrillary α -synuclein (α -Syn), heat shock proteins, and ubiquitinated proteins. It has been hypothesized that during disease progression ODCs take up soluble or oligomeric α -Syn from the extracellular environment. Furthermore, environmental influences such as oxidative or proteasomal stress may promote the aggregation of α -Syn and contribute to pathogenesis. To test this hypothesis ODCs (5 div) derived from the brains of newborn rats were incubated with recombinant human α -Syn (rh α -Syn) for different time periods and under various stress conditions. The data show that ODCs have the capability to take up and internalize α -Syn within 30 min. Immunoblot analysis demonstrates that α -Syn oligomers are formed intracellularly. Small α -Syn aggregates occur in a time-dependent manner, however they do not exert cytotoxic effects. Oxidative stress and inhibition of protein degradation systems augment the aggregate formation of α -Syn. To summarize, α -Syn is taken up by ODCs from the cell culture medium and small aggregates are formed in a time-dependent manner, which do not lead to cytotoxicity and cell death. Only when cells are subjected to an additional stress, aggregates are enlarged and cell death is promoted.

Septo-temporal modifications in adult hippocampal plasticity and neuronal integration in function of age and alpha-synuclein in a Parkinson's disease mouse model

Nada Ben Abdallah, Hanna Langemann¹, Jonathan Vogelsgang¹, Juergen Winkler¹

¹University Hospital Erlangen, Department of Molecular Neurology, Schwabachanlage 6, 91054 Erlangen, Germany

Adult neurogenesis in the dentate gyrus of the hippocampus decreases with age due to loss and/or dysfunction of neural stem and precursor cells. The nature of this decline is likely linked to cell-autonomous and non-autonomous modifications. In Parkinson's disease (PD), early accumulation of alpha-synuclein occurs in neuronal cell bodies, axons, and synapses in brainstem-hippocampal circuitries, and progresses with age, paralleling neuropsychiatric symptoms. The pathological consequence of alpha-synuclein overexpression on dentate neurogenesis still remains unclear. We used young and old transgenic mice overexpressing human wildtype alpha-synuclein in the forebrain and that have been advanced to model both neuropsychiatric and neurogenesis impairments of PD. We addressed cellular and molecular changes in relation to both age and alpha-synuclein using immunofluorescence and laser capture microdissection. We show that dentate neurogenesis decreases significantly in transgenic mice in an age-dependent manner, suggesting a link between alpha-synuclein accumulation and alterations in neurogenesis. Furthermore, we analyzed the volumetric densities of the mossy fiber axons projecting from granular dentate gyrus neurons onto pyramidal CA3 neurons. We observed a strong alteration in the volumes of the different mossy fiber projections in function of age, with a particular decrease in the suprapyramidal and the infrapyramidal projections. We further analyzed glial and vasculature markers associated with the neurogenesis niche and observed a significant age-dependent alteration in the density of hippocampal microvessels between transgenic and non-transgenic mice in a septo-temporal dependent manner. Immediate early gene expression was also analyzed in an attempt to evaluate the functional integration of new neurons in function of age and alpha-synuclein. Our findings demonstrate a critical alteration of neurogenesis-associated mechanisms in the dentate gyrus of aged mice, with an involvement of alpha-synuclein accumulation. These findings will further our understandings of the functional involvement of adult dentate neurogenesis in associated behavioral processes in PD.

Role of JNK in autophagic cell death in the cingulate cortex in a KA-induced rat model of epilepsy

Alessandro Vercelli, Marta Tropiano¹, Giada Spigolon¹, Christophe Bonny²

¹University of Torino, Neuroscience Institute of the Cavalieri Ottolenghi Foundation, regione Gonzole 10, 10043 Orbassano (TO), Italy ² Division of Molecular Genetics, CHUV, Lausanne, Switzerland

We have previously shown that the c-Jun N-terminal kinase (JNK) is involved in apoptotic cell death in the rat hippocampus in kainic acid (KA)-induced epileptic seizures and that JNK blockade by a cell penetrating specific inhibitor (D-JNKI-1) partially prevents neuronal cell death. Here we studied the role of autophagy and of apoptosis in neuronal cell death in the cingulate cortex in the same rats, and the effects of JNK inhibition.

Briefly, epileptic seizures were induced by intraperitoneal (i.p.) injection of 15 mg/kg KA (Tocris Bioscience). One hour after the injection, rats showed the first symptoms (immobility, facial myoclonus and head nodding), and only animals that reached the fourth and fifth stages of the Racine scale were included in the study. To minimize suffering and prevent mortality, 2 h following the onset a single i.p. injection of 4 mg/kg diazepam (Valium) blocked epileptic seizures within 30 min of administration. D-JNKI1 (DJ 0.3 mg/kg,) was injected i.p. 2 h following KA injection in the KA-DJ-1d and KA-DJ-5d groups. Rats were killed one and five days following KA injection, and perfused through the ascending aorta with saline followed by fixative. A series of cryostat section for each animal was Nissl-stained and neuronal counts were performed with StereoInvestigator software (MBF). Other sections were immunoreacted: i) for P-c-Jun as a marker for JNK activity as its elective target associated with microtubule-associated protein-2 (MAP2) (to confirm that JNK was involved in neuronal death); ii) for glial fibrillary acidic protein (GFAP) (to evaluate astrogliosis); iii) for Beclin-1 and LAMP-1 (as markers of autophagic processes); iv) for activated caspase 3 (as marker of apoptosis).

In Nissl-stained sections, an increase in necrotic cell death was found in KA-treated rats, both at 1 and 5 days, and neuronal density decreased by 40% at 1 day and by 70% at 5 days. Following D-JNKI-1 treatment, necrotic profiles almost disappeared at 1 day. Neuronal density was fully prevented by JNK inhibition at 1 day, and showed a 15% decrease at 5 days. C-Jun immunoreactivity colocalized with MAP2-immunoreactivity, showing that JNK was activated in neurons. Markers of autophagy were present in KA-treated rats and were almost absent following its inhibition. On the contrary, neither in Nissl-stained sections nor in activated caspase 3 immunoreacted sections apoptotic markers were found. In parallel, there was a striking astrogliosis in KA-treated rats, partially prevented by JNK inhibition.

Therefore, we show that in the cingulate cortex of rats KA-induced epileptic seizures induce a marked neuronal death, mostly due to necrotic and autophagic phenomena. This death is correlated with JNK activation: in fact, JNK inhibition almost completely prevents neuronal death and appearance of autophagic markers.

Supported by MIUR grants to AV.

Impact of proteasomal stress on the level of selected proteins of Bcl-2 family.

Peter Racay, Ivana Pilchova¹, Dusan Dobrota¹

¹Comenius University, Jessenius Faculty of Medicine, Department of Medical Biochemistry, Mala Hora 4, 03601 Martin, Slovakia

Post-translational modification of proteins by mono- or polyubiquitylation is a central mechanism to modulate a wide range of essential cellular functions. However, an insufficient proteasome degradation capability to cope with overproduced abnormal proteins and/or proteasomal stress has been implicated in numerous neurodegenerative conditions including ischemic brain injury.

The aim of this study was to investigate impact of ischemia-induced and bortezomib-induced proteasomal stress on the level of selected proteins of Bcl-2 family that are essential regulators of mitochondrial apoptosis. Rats were subjected to 15 minutes of global brain ischemia, using four vessel occlusion model, followed by 1, 3, 24 and 72 hours of reperfusion. Transient cerebral ischemia induced proteasomal stress that was manifested by massive accumulation of polyubiquitylated protein aggregates in the hippocampus 1 and 3 hours after ischemia as well as significant decrease of free ubiquitin observed at the same time of reperfusion. Level HSP70 was significantly elevated 24 and 72 hours after ischemia but we did not observe any significant changes of other stress proteins HSP90 and GRP78. Finally, the effect of ischemia on the level of selected proteins of Bcl-2 family (Bcl-2, Bcl-X, MCL-1, Bax, Bad and BIM) was investigated. Interestingly, neither ischemia nor ischemia followed with reperfusion had significant impact on the level of investigated proteins of Bcl-2 family.

Similarly to ischemia, proteasomal stress induced by incubation of neuroblastoma SH-SY5Y cells with bortezomib was manifested by massive accumulation of polyubiquitylated protein aggregates and increased level of HSP70. Bortezomib-induced stress of SH-SY5Y cells was also associated with cell death without significant changes of the level two pro-apoptotic proteins of Bcl-2 family that are regulated by proteasomal degradation, BIM and Bad.

Despite the possible involvement of proteasomal stress in ischemia-induced cell death, the exact mechanism of cell death related to proteasomal stress is not known and remains to be further investigated.

This work was supported by APVV grant no. 0245-11 to PR.

Effects of chronic subthalamic nucleus deep brain stimulation on the performance in the five choice serial reaction time task

Nadine Polascheck, Joachim K. Krauss¹, Kerstin Schwabe¹

¹Medical University Hannover, Neurosurgery, Carl-Neuberg-Str.1, 30625 Hannover, Germany

Deep brain stimulation (DBS) is an effective and accepted therapy option to treat motor symptoms in Parkinson`s disease. The subthalamic nucleus (STN) is the prevalent target region for DBS. Recent studies report on non-motor effects of STN DBS, which may be related to disturbances in associative and limbic subregions. These side effects range from depression to cognitive decline and impulsivity. The five choice serial reaction time task (5CSRTT) is a well described paradigm to test visual attention and impulsivity in rats. Lesions of the STN, as well as acute STN DBS have been shown to decrease accuracy and increase omissions in this paradigm. However, the deteriorating effect on premature responses was stronger after STN lesions than after acute STN DBS.

Since the effects of STN DBS may evolve over time, the present study investigated the effect of chronic bilateral STN stimulation in the 5CSRTT. Intact male Sprague Dawley rats were trained in this task until they reached a stable performance. Thereafter, electrodes were implanted bilaterally in the STN. After recovery from surgery the animals were retrained. Before starting the stimulation the threshold for individual stimulation-induced motor side effects (such as clonic paw movement or circling) was determined by stair-step wise increasing the current for each electrode (40-500 μ A, in 20 μ A steps). Afterwards continuous stimulation was started with a current of 20% below the individual threshold (130 Hz, 160 μ s). Sham stimulation was performed by connecting the rat to the cable but without applying any power. Rats were stimulated for four days and thereafter tested in the 5CSRTT during ongoing stimulation. The stimulation increased the percentage of omission and extended the response latency, but did not affect accuracy or premature responding (an indicator for impulsivity).

We here showed that chronic DBS deteriorate performance in the 5CRSTT, which differ, at least to some extent, from the effect of acute stimulation or lesions.

Neuronal cell death in inherited retinal degeneration is a surprisingly slow process

François Paquet-Durand, Ayse Sahaboglu¹, Olivier Paquet-Durand², Bernd Hitzmann², Per Ekstroem³, Marius Ueffing¹

¹University of Tuebingen, Cell Death Mechanisms Group, Roentgenweg 11, 72076 Tuebingen, GERMANY

² Institute of Food Science and Biotechnology, University of Stuttgart Hohenheim, GERMANY.

³ Ophthalmology Department, Lund University, SWEDEN

The question as to how long a neuron takes to die, from beginning to end, remains unanswered for most neurodegenerative diseases. To address this question, we used the rd1 mouse model for retinal neurodegeneration, which is characterized by phosphodiesterase-6 (PDE6) dysfunction and photoreceptor death triggered by high cGMP levels. Using cellular data on the progression of cGMP accumulation, cell death, and survival, we created mathematical models to simulate the temporal development of the degeneration and the clearance of dead cells. Both cellular data and modelling suggested that at the level of the individual cell, the degenerative process was rather slow taking approximately 80h to complete. To test the predictions of the model, we employed organotypic retinal explant cultures derived from wild-type animals and exposed to the selective PDE6 inhibitor zaprinast. Interestingly, here, detectable cGMP accumulation occurred only 36h after the beginning of PDE6 inhibition, suggesting the activity of compensatory feedback mechanisms. A measurable increase in cell death occurred only another 36h later. Together, our study allows discriminating three major stages in neuronal cell death: 1) an initiation phase taking up to 40h, 2) the execution phase lasting another 40h, and finally 3) the clearance phase lasting about 3h. This work also highlights the paradox that photoreceptor neurodegeneration, while very rapid at the tissue level, is governed by cell death mechanisms that are surprisingly slow, much slower than what would be expected, for instance, from apoptotic cell death.

Improvement and standardization of the pilocarpine model of temporal lobe epilepsy

Kathrin Töllner, Claudia Brandt^{1,2}, Wolfgang Löscher^{1,2}

¹University of Veterinary Medicine Hannover, Department of Pharmacology, Toxicology, and Pharmacy, Bünteweg 17, 30559 Hannover, Germany

²Center for Systems Neuroscience, Hannover, Germany

Diverse brain insults, including traumatic brain injury, tumors and prolonged acute symptomatic seizures, such as status epilepticus (SE), have the potential to induce the development of epilepsy, termed epileptogenesis. Epileptogenesis can be studied in post-SE models of temporal lobe epilepsy, e.g. the rat pilocarpine model (TURSKI et al., 1983). The goal of anti-epileptogenesis research is to identify therapeutic interventions that prevent, interrupt or reverse the epileptogenic process. Therefore, a potentially anti-epileptogenic drug or a cocktail of drugs can be administered after a pilocarpine-induced SE, i.e. during the latency period before spontaneous recurrent seizures (SRS) occur.

In order to reduce animal numbers, costs and labour, the ideal model has a high percentage of rats experiencing SE and a high incidence of SRS after a defined latency period. Furthermore, only a reliable SE termination after a defined SE length without recurrence of seizure activity renders animals with comparable insult severities for valuable anti-epileptogenesis studies. Different modifications of the pilocarpine model (lithium pre-treatment, repeated low-dose injection instead of pilocarpine bolus, SE termination after a defined SE length) have already resulted in reduced mortality (JOPE et al., 1986; GLIEN et al., 2001).

We now tried a) to optimize SE induction by intraperitoneal pilocarpine, b) to standardize SE termination, and c) to determine the critical duration of SE for induction of epileptogenesis with brain damage and behavioural alterations.

We found that a) a more individualized dosing scheme, i.e. intraperitoneal injection of a pilocarpine bolus plus repeated low-dose injections renders in a higher percentage of rats with SE; b) a three-step SE termination scheme, i.e. diazepam, phenobarbital and scopolamine for acute termination and up to 8 hours later via different administration routes, results in a true and reliable SE termination, and c) a SE duration of 60 min is too short to induce epileptogenesis, 120 min result in a poor general health state or death, but 90 min seem to be effective rendering > 70% of spontaneously epileptic rats.

Currently, we are determining the length of the latency period in the modified lithium-pilocarpine model. Moreover, we started to determine critical duration of SE in the intrahippocampal kainate model in freely moving rats and to standardize its SE termination.

Beneficial effects of mitochondria-targeted cholesterol oximes in mice over-expressing alpha-synuclein

Franziska Richter, Sheila M. Fleming¹, Fuying Gao¹, Vincent Lemesre¹, Magali Michaud², Chunni Zhu¹, Giovanni Coppola¹, Thierry Bordet², Rebecca Pruss², Marie-Francoise Chesselet¹

¹Department of Neurology, The David Geffen School of Medicine at UCLA, 710 Westwood Plaza, Los Angeles, CA 90095-1769, USA

²Trophos S.A., Parc Scientifique de Luminy, Case 931, 13288 Marseille Cedex 9, France

Mitochondrial dysfunction is present in dopaminergic neurons which predominantly degenerate in Parkinson's disease (PD). Neuroprotective drugs targeting mitochondria could therefore be beneficial in PD. Cholesterol-oximes are novel neuroprotective molecules with cytoprotective effects in cell-based assays and target outer mitochondrial membrane proteins. We have examined the effects of lead compounds TRO19622 and TRO40303 in mice over-expressing alpha-synuclein, a protein involved in both familial and sporadic forms of PD. Male mice expressing human alpha-synuclein under the Thy1 promoter (Thy1-aSyn mice, Masliah's line 61) and their wildtype littermates received TRO19622 and TRO40303 in food pellets from 1 to 4 months of age. Motor and olfaction deficits as well as alpha-synuclein pathology were examined. Tyrosine hydroxylase positive (dopaminergic) neurons were isolated from the substantia nigra (SN) by laser capture microdissection for transcriptome analysis. Neither compound showed any sign of toxicity or adverse effects. TRO4303 at the pharmacological (higher) dose improved the olfactory deficits in Thy1-aSyn mice after 2 months of administration. Importantly, the same dose of TRO4303 caused effects on a test of motor function, which was similar to that of dopamine agonists in this model. TRO40303 did not change the size of alpha-synuclein aggregates in the substantia nigra. Weighted gene co-expression network analysis (WGCNA) revealed that alpha-synuclein overexpression led to dysregulation of transcripts for 1103 genes, including genes implicated in mitochondrial function and oxidative stress (e.g. Bcl-2, Bax, Casp3, Nos2). TRO compounds normalized 20% of these changes, including transcripts related to mitochondria, cytoprotection and anti-oxidant response. Pathway analysis further revealed that TRO40303, which showed a stronger effect on gene expression, increased transcription of stress defense related genes (e.g. Prdx1, Prdx2, Glx2, Hspa9, Pink1, Trak1) and of dopamine-related genes (Th, Ddc, Gch1, Dat, Vmat2, Drd2, Chnr6a). This data suggest that cholesterol-oximes may counteract some pathology related to high levels of alpha-synuclein, and may be beneficial for the survival of nigrostriatal dopaminergic neurons in PD.

A Large Turkish Parkinson Pedigree with alpha-Synuclein Duplication: Blood Expression Biomarker Profile for Predictive Diagnostics

Georg Auburger, Suna Lahut², Özgür Ömür², Caroline Pirkevi², Hulya Tireli³, Eva Herrmann¹, Nadine Brehm¹, Suzana Gispert¹, Nazli Basak²

³Department Neurology, Haydarpasa Numune Training and Research Hospital, Istanbul, Turkey

Parkinson's disease (PD) is the second most common neurodegenerative disorder, affecting 2% of the population at old age. While most cases are sporadic, monogenic variants are found particularly in the early-onset group. Alpha-synuclein (SNCA) was the first Parkinson's disease gene to be identified in a large autosomal dominant Italian pedigree. Missense mutations and increased gene dosage were shown to cause monogenic PD with complete penetrance, while polymorphisms in the promoter and the mRNA 3' untranslated region were shown to enhance risk through elevated expression levels. SNCA gene variants are the most evident genetic risk among sporadic PD patients in genome-wide-association studies. The alpha-synuclein protein was found to aggregate in degenerating neurons, forming the microscopically detectable cytoplasmic "Lewy bodies" which are the diagnostic hallmark of PD upon autopsy.

We have now identified a large Turkish Parkinson pedigree with cosegregation of an alpha-synuclein gene duplication, including two patients, twelve presymptomatic mutation carriers and eight unaffected individuals who were cooperative. To study the effects of the alpha-synuclein gain-of-function in whole blood, firstly the 1.5-fold increase in transcript and monomeric protein levels were documented. Oligomers of the alpha-synuclein protein and high molecular weight aggregates were not detected in blood. Secondly, although the SNCA transcript levels showed high variance and their correlation with genotype did not attain statistical significance, mutation effects on the expression of several downstream genes were detectable, partially in significant association or statistical trends. The combined profile of these mRNA biomarkers upon ROC (receiver operating characteristic) curve analysis showed predictive diagnostic value with high sensitivity and specificity.

Its usefulness for subgroup diagnostics in Parkinsonism and for risk prediction of old-age sporadic PD remains to be tested. Objective predictive diagnostics are a prerequisite for neuroprotective therapy.

Correlation of candidate gene expression level with SNCA duplication

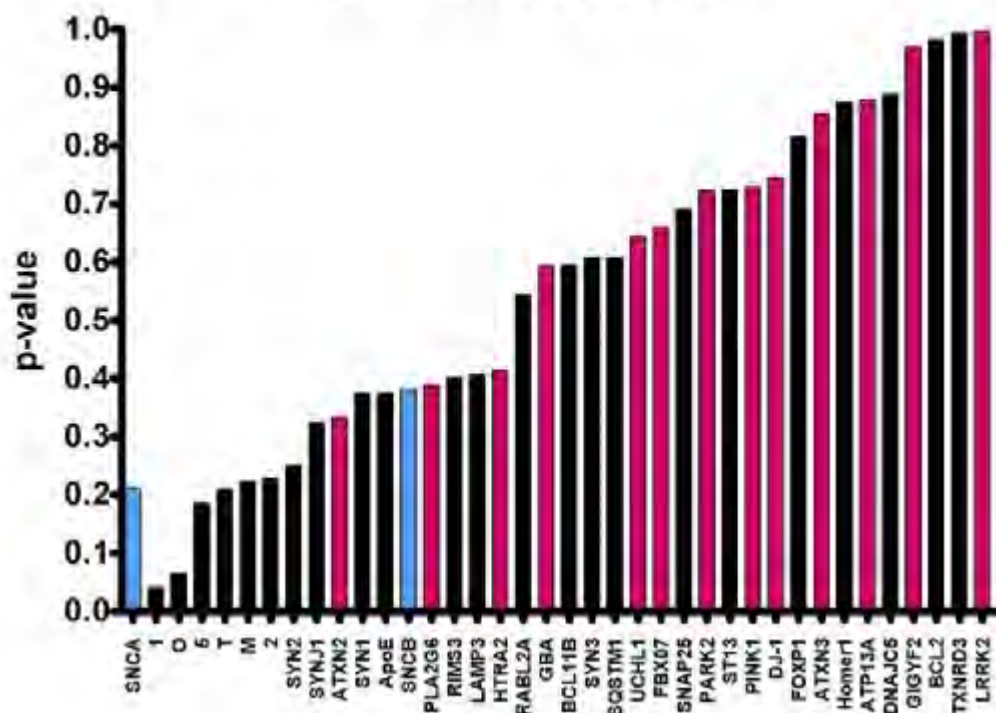

Immortalized mouse hypothalamic GT1-7 neurons as cell culture model for glutaminyl cyclase function

Corinna Höfling, Maike Hartlage-Rübsamen¹, Ulrike Zeitschel¹, Holger Cynis², Hans-Ulrich Demuth², Steffen Roßner¹

¹Leipzig University, Paul-Flechsig-Institute for Brain Research, Jahnallee 59, 04109 Leipzig, Germany

²Probiodrug AG, Weinbergweg 22, 06120 Halle/Saale, Germany

Glutaminyl cyclase (QC) is an enzyme known to catalyze the cyclization of N-terminal glutaminyl residues into pyroglutamate (pE). QC itself and many of its substrates such as neuropeptides and peptide hormones including orexin A, gastrin, gonadotropin- and thyrotropin-releasing hormones are highly abundant in hypothalamus and pituitary gland. The pE modification generally confers resistance to proteolysis and a higher aggregation propensity. Recently, QC emerged as a novel pharmacological target for Alzheimer's disease therapy because it was shown to catalyze the formation of highly pathogenic pE-A β peptides. However, functional QC studies in vitro are hampered by the lack of cell culture models with significant QC expression. Here we characterise the immortalized hypothalamic neuronal cell line GT1-7 with regard to expression of QC and its putative substrates by means of RT-PCR and immunocytochemistry. GT1-7 cells were analyzed in a proliferating state and after differentiation induced by serum deprivation. RT-PCR revealed robust expression of QC and an equal level of its homolog isoQC in differentiated GT1-7 cells. Among the peptide hormones, gonadotropin- and thyrotropin-releasing factor were detected by RT-PCR. Additionally, GT1-7 cells expressed significant amounts of the amyloid precursor protein as well as synaptophysin and synaptic vesicle protein 2A. In most cases, RT-PCR data were confirmed by immunocytochemical labellings. Our data suggest that GT1-7 cells are a promising in vitro model that allows to study the regulation of QC and isoQC expression, to identify novel QC substrates and to use it as a test system for QC inhibitors.

The EGF-like domain of Neuregulin 1 type III is liberated by ADAMs and BACE1

Michael Willem, Daniel Fleck¹, Christian Haass^{1,2}

¹Ludwig-Maximilians-University, Biochemistry, Schillerstrasse 44, 80336 Munich, Germany

²DZNE-Munich, Schillerstrasse 44, 80336 Munich, Germany

The generation of amyloid β -peptide ($A\beta$) from the amyloid precursor protein (APP) depends on sequential cleavage by β - and γ -secretase. Proteolytic processing of neuregulin 1 (NRG1) is dramatically reduced in BACE1 $-/-$ mice. Biochemical analysis revealed preferential BACE1 cleavage of the major NRG isoform, type III NRG1- β 1, expressed in the peripheral and central nervous system. BACE1 is a major therapeutic target for the prevention of Alzheimer's disease, since BACE1 is involved in the proteolytic generation of the neurotoxic amyloid β -peptide. Identification and functional investigation of their physiological substrates is therefore of greatest importance to anticipate unwanted side effects.

We investigated processing of NRG1 type III and demonstrate that the ectodomain can be cleaved by three different sheddases, namely ADAM10, ADAM17, and BACE1. Surprisingly, we not only found cleavage by ADAM10, ADAM17 and BACE1 C-terminal to the epidermal growth factor (EGF)-like domain, which is believed to play a pivotal role in signaling, but also additional cleavage sites for ADAM17 and BACE1 N-terminal to that domain. Proteolytic processing N- and C-terminal of the EGF-like domain results in the secretion of this domain from NRG1 type III. The soluble EGF-like domain is functionally active and stimulates ErbB receptor phosphorylation in tissue culture assays.

These studies confirm that BACE1 plays the predominant role in the β -site cleavage of NRG and suggests that inhibition of β -secretase activity could potentially interfere with NRG signaling in AD patients.

Impaired active avoidance memory in an animal model of Alzheimer's Disease, the APP/PS1 mouse

Carolin Rockahr, Michael Gruss¹, Laura Psotta², Thomas Endres², Volkmar Lessmann², Katharina Braun¹

¹Otto von Guericke University, Institute of Biology, Department of Zoology/Developmental Neurobiology, Magdeburg, Germany

²Otto von Guericke University, Institute of Physiology, Magdeburg, Germany

Alzheimer's disease (AD) is one of the most prominent neurodegenerative disorders associated with aging. AD is specifically characterized by deposition of beta-amyloid plaques and neurofibrillary tangles, first observed in the hippocampal and cortical brain regions. These dramatic changes of neuronal architecture are believed to underlie impaired learning and memory function observed in individuals suffering from AD.

To elucidate the biological causes of AD several animal models were developed. Among those, the APP/PS1 mouse model may be very promising, characterized by an overexpression of the amyloid precursor protein (APP) and presenilin 1 (PS1) and therefore these animals develop and manifest plaques in early stages of life. Previous studies revealed deficits in a spatial learning task, e.g. the Morris water maze task (see poster of Psotta et al.). However, it is likely to hypothesize that those learning deficits are not restricted to this special learning paradigm. Therefore, in the present study we investigated the performance in an associative learning paradigm, the two-way active avoidance task (TWA). APP/PS1 and wildtype mice were trained at the age of five, seven and nine months in a standardized five-day training procedure. No significant differences in avoidance learning were detected between the APP/PS1 and wildtype mice. However, if re-trained two months later, the APP/PS1 mice showed deficits in long-term memory function. In contrast to the wildtype animals, in which the first TWA training improved their learning performance during the second re-training (indicating that they can recruit information from the first training during the second training), the learning performance of the re-trained APP/PS1 did not differ from the first training session.

In conclusion, these results point to a specific impairment of APP/PS1 mice in long-term memory function associated with high plaque loading. In future experiments, by using the Golgi-Cox staining method and analyzing the architecture of neurons in the hippocampus and medial prefrontal cortex we aim to investigate the underlying biological basis of the memory deficits observed in the APP/PS1 mice.

Supported by the Center for Behavioral Brain Sciences (CBBS 3804 G; EFRE: 1211080005).

Validation of a rotenone-induced rat model of Parkinson's disease: behavioral and electrophysiological measures

Christof v. Wrangel, Kerstin Schwabe¹, Joachim K. Krauss¹, Mesbah Alam¹

¹Hannover Medical School, Department of Neurosurgery, Carl-Neubert-Straße 1, 30625 Hannover, Germany

Introduction: The 6-hydroxydopamine (6-OHDA) Parkinson (PD) rat model is based on specific dopamine depletion in the nigrostriatal pathway, which leads to hyperactivity of the subthalamic nucleus (STN). Chronic rotenone injections similarly lead to loss of dopaminergic neurons in the nigrostriatal pathway but in addition also to loss of cholinergic neurons in the pedunculopontine nucleus (PPN), which has been thought to underly certain components of parkinsonian gait. We here evaluated the motor disability and the extra cellular neuronal firing activity of the STN in the rotenone rat model of PD.

Methods: Male Sprague Dawley rats were treated with chronic rotenone injections (2.5 mg / kg bodyweight, i.p.) for 60 days. Control rats received vehicle injections. After the end of the treatment motor coordination was assessed by using the Rotarod test. Thereafter, single unit activities and local field potentials were recorded in the STN in urethane 1.2 g/kg anesthetized rats.

Results: Rotenone injected rats spent significantly less time on the Rotarod as compared to vehicle treated rats. Further, electrophysiological data showed a higher firing rate and higher beta oscillatory activity in the STN.

Conclusion: Similar as in 6-OHDA injection we found enhanced STN neuronal firing rates as well as increased beta oscillatory activity, key features of PD, in this model. The rotenone-induced rat model of PD should deserve further attention since it covers more aspects than just the dopamine depletion.

ROCK inhibition in a cell culture model of a-synuclein aggregation

Hagen Lothar Walle, Lars Tatenhorst¹, Lars Tönges¹, Tiago Fleming Outeiro², Mathias Bähr¹, Paul Lingor¹

¹University Medicine Göttingen, Neurology, Waldweg 33, 37073 Göttingen, Germany

²University Medicine Göttingen, Neurodegeneration and Restorative Research, Waldweg 33, 37073 Göttingen, Germany

Parkinson's disease (PD) is the second most common neurodegenerative disorder. In addition to the degeneration of the nigrostriatal projections, the presence of alpha-synuclein positive Lewy bodies is a hallmark of the disease. In our previous studies in cell culture and animal models of PD we identified Rho kinase (ROCK) as a novel molecular neuroprotective target, showing that inhibition of ROCK prevented neurodegeneration and fostered regeneration. Because aggregation is a major pathophysiological step in the development of PD, we here aimed to evaluate a putative anti-aggregative potential of ROCK inhibition.

To elucidate the effect of ROCK inhibition on alpha-synuclein aggregation, we used an established cell culture model consisting of the co-expression of alpha-synuclein and the alpha-synuclein interacting protein synphilin-1 in H4 neuroglioma cells. Aggregates were visualized by immunostaining and fluorescence microscopy 24 h after transfection.

H4 neuroglioma cells were treated pre and post transfection with the ROCK inhibitors Fasudil and Y-27632 in concentrations in the range of 5 to 100 μ M. The number and size of the developing aggregates were determined. Our preliminary results suggest a reduced alpha-synuclein aggregation after ROCK inhibition.

- Fig. 01: H4 neuroglioma cells double transfected with plasmids expressing alpha synuclein (SNCA) and synphilin (SNCAIP), 24 h after transfection, stained with the appropriate fluorescently labeled antibodies. Scale bar: 50 μ m.

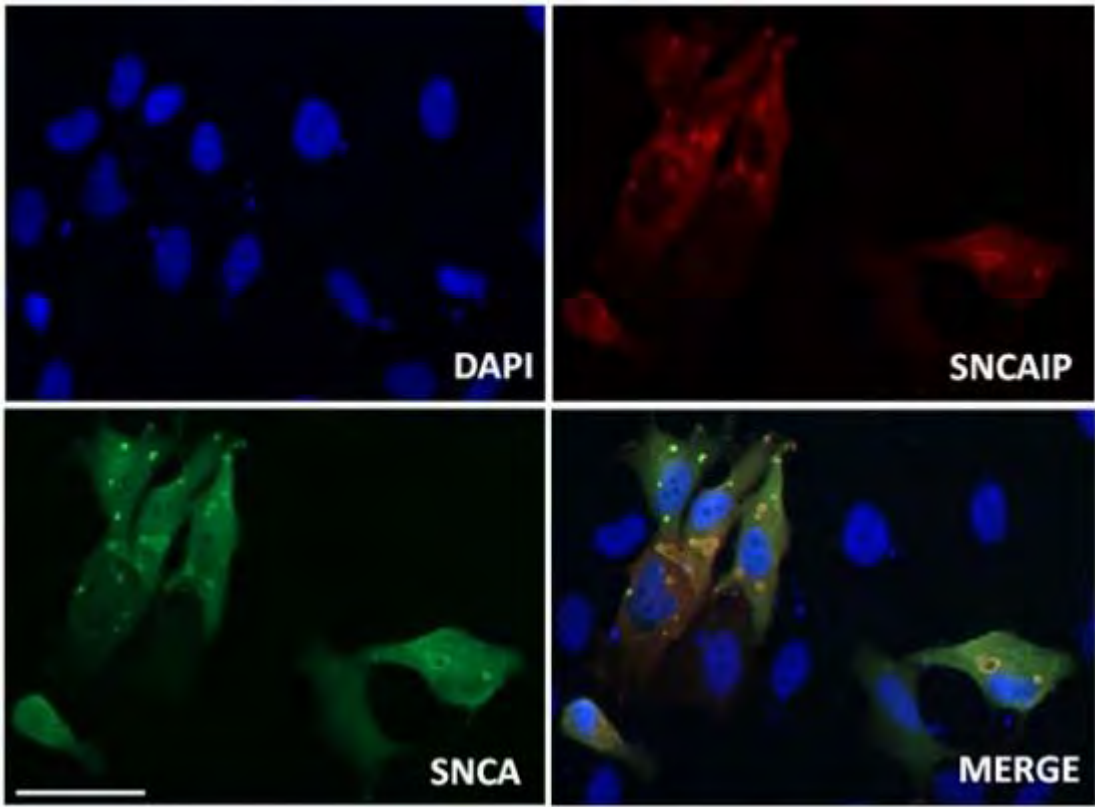

Intracellular BDNF transport is impaired in mouse models of Alzheimer's disease

Bianca Seifert, Volkmar Leßmann¹, Tanja Brigadski¹

¹ Otto von Guericke University, Institute of Physiology, Leipziger Straße 44, 39120 Magdeburg, Germany

The neurotrophin BDNF is an important growth factor supporting the development of neuronal networks. To perform its biological functions, anterograde and retrograde transport processes are crucial to transfer BDNF from the trans-Golgi-network to its target locations. Recent studies indicated a disturbed transport of BDNF vesicles as a possible reason underlying neuronal degeneration in Alzheimer's disease and Huntington's disease.

Here we analyzed the effect of amyloid precursor protein (APP), as one of the causative factors in Alzheimer's disease, on the transport of BDNF-containing vesicles in primary cultures of postnatal mouse hippocampal neurons. In a first set of experiments using immunocytochemistry with APP antibodies we could prove colocalization of N-terminal as well as the C-terminal parts of APP in secretory granules of hippocampal neurons from WT animals. Therefore, the influence of APP on the transport of BDNF-containing vesicles was tested in an Alzheimer disease mouse model (5xFAD) which overexpresses APP at postnatal day 5 under the control of the Thy1 promotor. To analyze the transport of BDNF-containing vesicles in real time, hippocampal cultures of transgenic mice and their wildtype littermates were transfected with BDNF-mCherry 10 days after birth. We observed a significant decrease in the mobility of BDNF-containing vesicles in transgenic mice compared to the wild type controls one day after transfection. The mean velocity of vesicles was significantly decreased, while the stopping frequency was increased. This effect remained unchanged during all three days of analysis. Altogether, these changes resulted in a significantly decreased mobility of BDNF-containing vesicles. To test whether the transport of BDNF-containing vesicles is similarly impaired if APP is expressed for shorter periods we co-transfected hippocampal neurons with BDNF-mCherry and APP-YFP and mimic an early APP overexpression. Three days after transfection a significant decrease in the mean velocity of vesicles compared to control was detected. We did not observe a correlation between the extent of impaired vesicle mobility and the degree of APP overexpression in individual neurons. The absence of such a correlation between the strength of APP expression and the mean velocity of vesicles indicates that APP cleavage products in the culture medium are more likely to be the trigger of the impaired transport. To test if the disturbance of transport is mediated by factors released into the extracellular medium, coverslips with BDNF-mCherry transfected hippocampal neurons which did not overexpress APP were transferred into culture medium enriched with APP cleavage products. Interestingly, BDNF vesicles of these control cells showed a significant decrease in the mean vesicle velocity in the presence of extracellular APP cleavage products.

Taken together these data suggest an influence of soluble APP products released into the medium on the transport of BDNF containing vesicles in hippocampal neurons. The decreased BDNF vesicle transport and subsequently diminished release of BDNF might contribute to neurodegeneration in AD.

This study was supported by NeuroNetworks NN11 from the CBBS/EFRE program

Expression analysis of dopaminergic marker genes in tyrosine hydroxylase positive neurons in the striatum of TH-eGFP mice by laser microdissection

Martin Kliez, Candan Depboylu², Wei-Hua Chiu², Kazuto Kobayashi³, Eberhard Weihe¹, Martin K.-H. Schäfer¹

¹Molecular Neuroscience, Philipps University, Marburg, Germany

²Department of Neurology Philipps University, Marburg, Germany

³Department of Molecular Genetics, Institute of Biomedical Sciences, Fukushima Medical University School of Medicine, Fukushima, Japan

The striatum is the most densely innervated brain region by dopamine (DA) ergic fibers, which originate from the substantia nigra pars compacta (SNc). Striatal DA levels decrease during clinical progression of Parkinson's disease (PD), resulting in the 3 characteristic clinical symptoms rest tremor, bradykinesia and rigidity. Over the last 20 years studies in several species have indicated striatal interneurons as a possible source of DA in the striatum itself and suggested them as part of a compensatory mechanism in early PD. It was shown that these neurons have a GABAergic phenotype based on GAD67 expression, display the typical morphology of interneurons and express tyrosine hydroxylase (TH) the first and rate-limiting enzyme of the catecholamine synthesis pathway. This interneuronal subtype increases in number after DA depletion, but the underlying mechanisms are still unknown. Whether these neurons are DAergic is still controversial.

To characterize the chemical phenotype of these TH expressing neurons in the intact and DA depleted nigrostriatal system in more detail, we examined adult male TH-eGFP transgenic mice and performed a cellular phenotype analysis using laser capture microdissection (LCM) of prelabeled GFP+ striatal neurons in combination with RT-PCR and compared the expression pattern to that of DAergic neurons of the SNc. The expression of all marker genes required for a full DAergic phenotype (TH/AADC/DAT/VMAT2) was detected in DAergic neurons in the SN. In contrast, in the striatal GFP+ neurons only TH transcripts were detectable. In the striatal GFP- and GFP+ neurons transcripts for GAD65, GAD67 and VIAAT are expressed. Of the striatal neuropeptides enkephalin, dynorphin and substance P the striatal GFP+ neurons only express dynorphin and substance P, but not enkephalin. To test whether the GFP+ neurons could be functional targets of DAergic innervation we examined the expression of dopamine receptors (DdR). We found only transcripts for Dd2R and for DARPP32 in the GFP+ striatal interneurons, but none of the other receptor subtypes.

These data demonstrate that striatal TH expressing interneurons express a complete GABAergic phenotype with incomplete catecholaminergic traits. Their so-called DOPAergic phenotype (TH+/AADC-/DAT-/VMAT2-/VMAT1-) is not changed after DA depletion. However, TH expression in these neurons could be regulated by the DAergic innervation via Dd2R involving DARPP32. Molecular and pharmacological targeting these neurons may provide further insights in the complex intrastriatal processing of basal ganglia function and may open new therapeutic avenues in the treatment of PD.

The NKCC1-inhibitor bumetanide does not enhance the effect of GABA- potentiating drugs on status epilepticus in rats.

Claudia Brandt, Kathrin Töllner^{1,2}, Gerda Brunhofer³, Thomas Erker³, Mario Gabriel³, Peter W. Feit¹, Wolfgang Löscher^{1,2}

¹University of Veterinary Medicine, Dept. of Pharmacology, Toxicology and Pharmacy, Bünteweg 17, 30419 Hannover, Germany;

²Center of Systems Neuroscience, Hannover, Germany;

³Department of Medicinal Chemistry, University of Vienna, Austria

Recent studies indicate that the development of hyperexcitability of neurons and neuronal circuits are crucial for the development of epilepsy after an initial insult to the brain. In this context, the expression changes of cation-chloride-co-transporters have gained growing interest. Changes in the expression pattern of the K⁺-Cl⁻ co-transporter KCC2 (downregulation) and the Na⁺-K⁺-2Cl⁻ co-transporter (upregulation) lead to a GABA-shift from an inhibitory to an excitatory action caused by an accumulation of intracellular chloride. It is assumed that insults to the brain provoke this shift in GABA action in a subset of GABAergic neurons. This in consequence contributes to the development of epileptic networks. Under these circumstances NKCC1-inhibitors could be a useful tool to counteract the upregulation of NKCC1, and so, may prevent neuronal hyperexcitability and the development of epileptic networks.

Several studies indicate that NKCC1 is upregulated in animal models of temporal lobe epilepsy (TLE). In several of these models the induction of a status epilepticus (SE) with either electrical or chemical means is used as the epilepsy-inducing initial insult. The termination of a SE by GABA-enhancing drugs such as phenobarbital (PB) is often not satisfactory. This could be evidence that a shift from inhibitory to excitatory GABA action already takes place during SE.

The aim of the present study was to investigate whether the inhibitor of the NKCC1-transporter, bumetanide, is able to enhance the effect of GABA enhancing drugs on SE in rats. Bumetanide is a diuretic drug and hardly enters the brain. Therefore we synthesized the *N,N*-dimethylaminoethyl ester of bumetanide (BUM5) to enhance brain concentration of bumetanide.

SE was induced in male Sprague Dawley rats by systemic pilocarpine or kainate injections or by electrical stimulation of the basolateral amygdala. One group of rats was anaesthetised with the GABAergic anesthetics urethane or chloralhydrate before induction of SE. The second group was unanaesthetised. Bumetanide or BUM5 were administered intravenously twice at an interval of 30 min. The time point of bumetanide or BUM5 injection after onset of SE depended on the induction methods. The duration of SE should exceed the critical duration necessary for induction of epileptogenesis, which varies between the models. In unanaesthetised rats, PB was injected once at the same time as the second bumetanide or BUM5 injection. PB was administered in a dosage that hardly had an effect on SE by itself. Control rats received saline instead of phenobarbital or saline instead of bumetanide or BUM5.

Neither bumetanide nor BUM5 exhibited an anticonvulsant effect on SE. Both drugs did not enhance the effect of GABA potentiating drugs on SE. The manner of SE induction had no impact on the effect of bumetanide.

The strategy used in the present study did not reveal an effect of bumetanide on SE termination in rats. There are different reasons that can account for these results. First, it could be due to methodological problems e.g. the time point of bumetanide or PB injection, or the concentration of bumetanide in the brain. Second, it could also indicate that the blockade of the NKCC1 transporter is not the right strategy to reverse the GABA shift. Third, it might be that the GABA shift is not critically involved in the maintenance of SE.

Supported by Deutsche Forschungsgesellschaft *FOR 1103*

The Interplay Between α -Synuclein and Rab GTPases: Insight into The Molecular Basis of Synucleinopathies

Sibylle Elisabeth Eisbach, Tiago Fleming Outeiro¹

¹University of Göttingen, Department for Neurodegeneration and Restorative Research, Waldweg 33, 37073 Göttingen, Germany

A variety of age-related neurodegenerative disorders is associated with the pathological aggregation of proteins. α -Synuclein (α Syn) is the major component of Lewy-bodies the typical pathological hallmark of Parkinson's disease and other synucleinopathies. The cellular mechanism by which α Syn relates to neuronal death remains unknown and its cellular function is still unclear, although it has been strongly implicated in protein trafficking. Rab GTPases are important coordinators of membrane trafficking, including vesicle formation and movement. More than 60 members of this family have been identified in humans in total, many of which have different isoforms. Rab proteins are present in active and inactive forms. Activated Rabs and their isoforms in turn interact with effector proteins and, therefore, represent molecular switches. All Rab GTPases are usually confined to specific compartments within the cell in a tightly regulated fashion. Here, we show the typical localization of selected Rab proteins and that their spatial integrity can be disrupted by the simultaneous overexpression of α Syn in a cellular model of α Syn inclusion formation. In the same model, we investigate the effect of Rab overexpression on the solubility characteristics of α Syn inclusions. Furthermore, we show that co-overexpression of selected Rab GTPases can lower α Syn induced toxicity.

Generation and functional analysis of dopaminergic reprogramming factors for protein transduction

Sebastian Neumann, Naemi Treuter¹, Dennis Paliga¹, Koushik Chakrabarty¹, Rolf Heumann¹

¹Ruhr-University of Bochum, Faculty of Chemistry and Biochemistry, Department of Molecular Neurobiochemistry, Universitätsstr. 150, 44780 Bochum, Germany

Meso-diencephalic dopaminergic (mdDA) neurons are critical for motor control and cognitive functioning and their loss or dysfunction is associated with disorders such as Parkinson's disease (PD). In animal models of PD, symptoms of dopamine deficiency could be restored by transplanted dopaminergic neurons derived from embryonic stem cells. Due to ethical issues, human embryonic stem cells cannot be used for the generation of mdDA neurons in the context of future cell replacement therapies for PD. Recently, Caiazzo *et al.*, showed that mouse and human fibroblasts can be directly converted to functional dopaminergic neurons by viral-based expression of the three transcription factors Lmx1a, Mash1 and Nurr1 (Caiazzo, M., *et al.*, Nature 476, 224–227, 2011). Nevertheless due to their high risk of side effects, viruses cannot be used in therapies for humans. An alternative approach would be protein transduction, in which heterologous expressed protein of interest can be taken up by cells with the help of a fused cell penetrating peptide (CPP). One of the prominent examples of CPPs is the basic peptide TAT (trans-activator of transcription) derived from human immunodeficiency virus type 1 (HIV-1) (Fawell, S., *et al.*, PNAS 91, 664-8, 1994).

Here, we report the cloning of the three human transcription factors Lmx1a, Mash1 and Nurr1 as N-terminal fusion proteins to a His-tag, the TAT-domain and a nuclear localization sequence (NLS) into the pTriEx-vector system obtaining HTN-Lmax1a, HTN-Mash1 and HTN-Nurr1. After bacterial expression and His-tag based purification of each of the transcription factors, its cellular uptake was studied in the human neuroblastoma cell line SH-SY5Y. Individual transcription factors were labelled with the fluorescent dye Rhodamine so that the cellular uptake could be confirmed by fluorescence microscopy. Furthermore, we verified the biological activity of the transduced transcription factor proteins by quantifying the mRNA levels of their respective downstream targets by real-time qPCR.

Taken together, we show the generation of cell penetrating and physiologically relevant transcription factors for direct conversion of mdDA.

Effects of cyclosporine A on seizure thresholds in acute and chronic epilepsy models

Annelie Handreck, Deborah Annina Elger², Laura Gey¹, Manuela Gernert¹

¹ Department of Pharmacology, Toxicology, and Pharmacy, University of Veterinary Medicine Hannover, and Center for Systems Neuroscience, Hannover, Germany;

² Leibniz University Hannover, Germany

About 30% of patients suffering from epilepsy are pharmacoresistant, meaning that seizures occur despite appropriate treatment with antiepileptic drugs. Neural transplantation of inhibitory cells into brain regions involved in seizure generation or propagation is one promising approach to overcome this problem. Depending on the grafted cell type (e.g. xenotransplantation), an immunosuppression is necessary to prevent host tissue reactions or graft rejection and to promote long-term anticonvulsant effects. However, conflicting data indicate that a treatment with the commonly used immunosuppressive drug cyclosporine A (CsA) might itself act pro- or anticonvulsant in different seizure and epilepsy models.

In the present study, we comprehensively investigated different doses (5 mg/kg or 10 mg/kg), application routes (i.p. or s.c.), and preparations of CsA (pure substance, Sigma-Aldrich, solved in Cremophor EL, or a dilution of the ready-to-use-drug Sandimmun[®], Novartis, containing Cremophor EL and ethanol) on seizure thresholds in rat models. We used two different models, an acute seizure model, the timed intravenous pentylenetetrazol (PTZ) seizure threshold test, as well as a chronic epilepsy model, the amygdala kindling model. Therefore, female rats were daily injected with either pure CsA or Sandimmun[®] over a period of 15 days. Control groups received the respective vehicles of the two preparations or did not receive any substance at all. The individual seizure thresholds of the animals were determined at different time points: 7 days prior to the beginning of immunosuppression (control threshold), 2 hours after the first application (acute), at day 8 and 15 of treatment (chronic), and again 7 days after the end of immunosuppression (day 22, washout). Additionally, behavioral tests were conducted at the different time points to detect putative side effects of the immunosuppression. Finally, blood samples were taken 150 minutes after drug administration for analysis of CsA whole blood levels. Preliminary data did not indicate robust acute or chronic effects of an intraperitoneally applied immunosuppression with either pure CsA or Sandimmun[®] on seizure thresholds, even though the 10 mg/kg Sandimmun[®] dilution still contains 2.29% ethanol. The analysis of blood samples indicated that the resorption of intraperitoneally applied CsA from Sandimmun[®] exceeds the resorption from the pure CsA preparation. Observed unwanted side effects included transient gastrointestinal problems such as diarrhea. We are currently completing the study by evaluation of the effects of subcutaneously applied pure CsA and Sandimmun[®] on seizure thresholds. Our preliminary data indicate that an immunosuppression with CyA might be a safe and feasible option for use in neural transplantation experiments in the PTZ and amygdala kindling model.

Supported by a grant (FOR 1103, GE1103/7-1) from the German Research Foundation. Whole blood samples were analyzed in the Institute for Clinical Chemistry, Hannover Medical School. Annelie Handreck was supported by the Jung-Stiftung für Wissenschaft und Forschung, Hamburg.

Evaluation and pharmacokinetic characterization of the radiotracer ^{123}I -FP-CIT using single photon emission computed tomography (SPECT) in a non-human primate model of Parkinson's disease

Enrique Garea-Rodríguez, Christina Schlumbohm², Boldizsár Czéh^{1,3}, Jessica König^{1,4}, Gunther Helms⁵, Cornelia Heckmann¹, Birgit Meller^{6,7}, Johannes Meller⁷, Eberhard Fuchs^{1,4}

¹Clinical Neurobiology Laboratory, German Primate Center, Göttingen, Germany

²Encepharm, Göttingen, Germany

³Molecular Neurobiology, Max-Planck Institute of Psychiatry, Munich, Germany

⁴Center for Molecular Physiology of the Brain (CMPB), University of Göttingen, Göttingen, Germany

⁵Department of Cognitive Neurology, University Medical Center, Georg-August-University Göttingen, Göttingen, Germany

⁶Department of Nuclear Medicine, Martin-Luther-University Halle, Halle, Germany

⁷Department of Nuclear Medicine, University Medical Center, Georg-August-University Göttingen, Göttingen, Germany

Single photon emission computed tomography (SPECT) imaging plays an increasing role in preclinical research in the field of Parkinson's disease. The aim of the study was to establish a protocol for imaging the dopamine transporter (DAT) in common marmoset monkeys (*Callitrix jacchus*). Serial SPECT and structural magnetic resonance imaging (MRI) were performed on an upgraded clinical scanner to determine the distribution kinetics of ^{123}I -*N*- ω -fluoropropyl-2 β -carbomethoxy-3 β -{4-iodophenyl}nortropine (^{123}I -FP-CIT) and the underlying brain anatomy. After intravenous injection of approximately 60 MBq of ^{123}I -FP-CIT, stable and specific striatal uptake was observed for at least four hours. Analysis of plasma samples showed rapid disappearance of the radiotracer from blood plasma within a few minutes after application, with activity declining to 4.1% of the administered activity. In a marmoset model of Parkinson's disease, which was generated by unilateral injections of 6-hydroxydopamine (6-OHDA) into the nigro-striatal projection pathway, complete loss of striatal DAT binding in combination with behavioural deficits was observed. The combination of ^{123}I -FP-CIT SPECT and MRI enables detection of small dopaminergic brain structures and are suitable methods for use in preclinical marmoset models of Parkinson's disease.

Supported by the DFG Research Center of Molecular Physiology of the Brain (CMPB) and GE Healthcare (Munich, Germany). EGR was funded by EU ERA-Net NEURON.

Electron Microscopy of Amyloid Fibre Aggregates induced by the Presence of SERF Protein

Gerd Leitinger, S. Fabio Falsone²

¹Medical University of Graz, Institute of Cell Biology, Histology and Embryology, Harrachgasse 21, 8010 Graz, Austria

²Karl-Franzens University of Graz, Institute of Pharmaceutical Sciences, Humboldtstraße 46, 8010 Graz, Austria

Amyloids (insoluble fibrous proteins aggregates) can be formed by the aggregation of inappropriately folded proteins. These are known to be implicated in a variety of fatal neurodegenerative disorders such as Alzheimer's disease, Huntington's disease, prion – related encephalopathies, and Parkinson's disease . We have recently shown that SERF protein can directly interact with several, structurally unrelated, amyloid precursor proteins and accelerate amyloid formation by reducing the half-time of conversion and by accelerating the initial lag-phase of conversion (Falsone et al., Cell Report 2012 30:358-71). When incubated with alpha synuclein, which is known to accumulate in neurons of patients with Parkinson's disease, SERF protein can bind to the C-terminal region of alpha synuclein, and promote the formation of amyloid aggregates.

Here we demonstrate, with negative staining transmission electron microscopy, the process of amyloid growth in the presence or absence of SERF protein, using alpha synuclein as a model amyloid precursor protein . For this, protein suspensions were placed onto TEM grids, negatively stained with uranyl acetate, and examined using an FEI Tecnai 20 transmission electron microscope.

When 150µM alpha-synuclein were incubated with 100M SERF 1A for up to 30-40 h, more and more aggregates were detected with lengths of 50-400 nm, occurring together with small, blob-like protein aggregates with a diameter of only 20-30 nm (Fig. 1). At a later stage, when the aggregates were turned into large, insoluble amyloid fibres, the small blobs disappeared and the samples only consisted of elongated fibres of several hundreds of nm in length. These fibres were indistinguishable morphologically from those by self- nucleation of alpha – synuclein in the absence of SERF 1A. No protein aggregates were detected when SERF 1A was incubated alone. Dead-end aggregates, which were produced by incubating alpha-synuclein with dopamine, were clearly visible as blobs of 20 nm diameter, but did not grow any further and could not be influenced by the presence of SERF 1A.

These findings corroborate the hypothesis that the binding of SERF proteins to amyloid precursor proteins promotes the formation of intermediate aggregates. These aggregates then self-nucleate to form insoluble amyloids.

Acknowledgements:

This work was supported by the Austrian Science Fund (Projects P22400 to and P22630). We thank Gertrud Havlicek for preparing the TEM samples.

Figure 1:

Alpha-synuclein aggregates of various lengths are visible after incubation of alpha-synuclein with SERF 1A

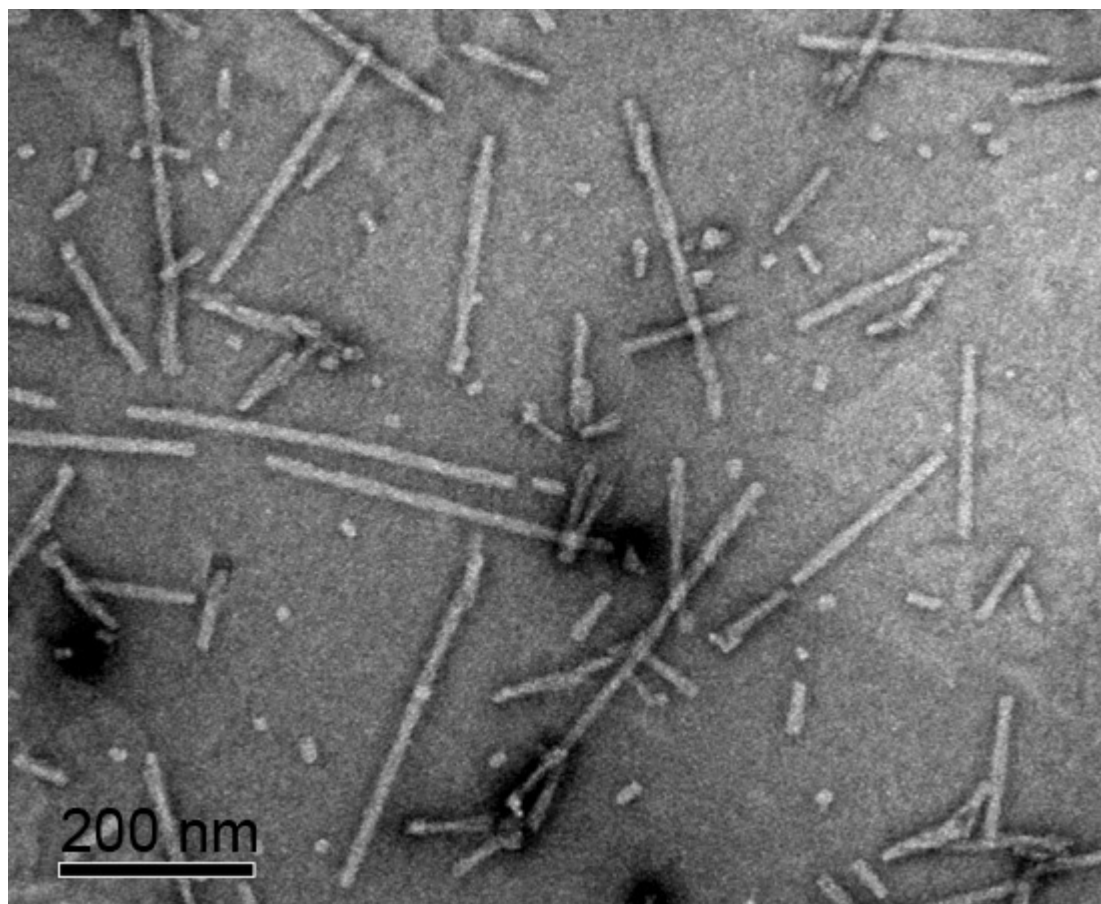

The role of apolipoproteins in cuprizone induced demyelination and subsequent remyelination

Birte Könnecke, Mathias Bähr¹, Mikael Simons^{1,2}

¹Georg-August-University, Department of Neurology, Göttingen, Germany

²Max-Planck-Institute of Experimental Medicine, Göttingen, Germany

Multiple sclerosis (MS) as chronic autoimmune disease of the central nervous system (CNS) shows a heterogeneity in clinical course, immunology and pathology. It is characterized by large, multifocal plaques with gliosis of microglia and astrocytes, demyelination and axonal loss as the major cause of irreversible neurological deficits.

During demyelination of axons a high amount of myelin debris is produced and within further process removed by macrophages - a function that may be beneficial to remyelination. Cholesterol is one essential structural component of myelin and it seems that the brain cholesterol content is entirely produced locally with high synthesis in the developing CNS and low levels in the adult CNS. This decrease could be explained by effective recycling of cholesterol-containing myelin debris.

In the cuprizone mouse model of multiple sclerosis the feeding of animals with the neurotoxin cuprizone (cprz) induces reproducible and extensive demyelination. After withdrawal of the toxin also remyelination and regenerative processes can be investigated. Despite less knowledge about the transfer of cholesterol between cells of the CNS to support remyelination, it is known that apolipoprotein E (ApoE) is one important protein involved in the lipid metabolism of the brain.

We investigated in a first experiment the expression of different apolipoproteins in male C57Bl/6 mice at different time points during 5 weeks of cuprizone induced demyelination and additional 4 weeks of normal diet as recovery/remyelination phase. The cprz fed mice significantly lost body weight during cprz feeding, but regained it immediately after switch to normal diet. We could show an increase of ApoE expression until week 5 of cprz induced demyelination. After withdrawal of the toxin the expression dropped to a normal level at week 2 and increased again until week 4 of recovery, although at this time point the myelin state gained to normal levels.

Since we could show this regulation of ApoE expression, we aimed to investigate in a second study the differences in pathology of cprz induced de- and remyelination between wild type and ApoE deficient mice. Interestingly, ApoE deficient mice showed less weight loss and demyelination in comparison to wild type mice. Furthermore, we included male and female mice in this study and could detect a gender specific difference in both, wild type as well as ApoE ko strains, with a worse outcome in male than female mice.

Since ApoE is mainly expressed by astrocytes and to a lesser extent by microglia and macrophages it has to be evaluated, if this ApoE dependent response to cprz induced demyelination is due to an altered glial activity. It also has to be evaluated if other apolipoproteins expressed in the brain play a compensatory role in this process.

H₂S production inhibition in an experimental model of seizures: EEG and behavioral effects

Dragan Hrcic, Aleksandra Rasic - Markovic¹, Veselinka Susic², Dragan Djuric¹,
Olivera Stanojlovic¹

¹Belgrade University Faculty of Medicine, Institute of Medical Physiology "Richard Burian", Visegradska 26/II, 11000 Belgrade, Serbia

²Serbian Academy of Sciences and Arts, Knez Mihailova 35, 11000 Belgrade, Serbia

Seizures induced by lindane in rats are suitable animal model of generalized epilepsy. H₂S has been recently recognized as endogenously produced gaseous neurotransmitter with different physiological and pathological roles. Major enzyme responsible for H₂S production in the brain is cystathionine- β -synthase (CBS). The aim of this study was to investigate the effects of inhibition of H₂S production using aminooxyacetate, CBS inhibitor, on EEG and behavioral manifestations of seizures induced by lindane in rats.

Male Wistar albino rats with previously implanted electrodes for in vivo EEG registration were intraperitoneally (i.p.) treated with lindane 4 mg/kg and observed for convulsive behavioral and EEG manifestations during next 30 min. Aminooxyacetate (27 mg/kg) or saline were injected 30 min prior to lindane administration. Convulsive behavior was assessed by seizure incidence, latency time to first seizure onset and its severity assessed by descriptive scale with 4 grades. Time to first ictal period and duration of ictal periods in EEG were also analyzed.

Seizure incidence was higher in rats treated with aminooxyacetate prior to lindane, but the difference were not statistically significant comparing with those treated only with lindane. However, administration of aminooxyacetate significantly decreased the latency time to first seizure and significantly augmented severity of lindane-induced seizures. EEG analysis revealed decreased time to first ictal period and increased duration of ictal periods in rats receiving aminooxyacetate prior to lindane.

These results showed that inhibition of H₂S production aggravated seizures induced by lindane in rats.

Electrical Imaging of Local Field Potentials and Single Unit Activity in Organotypic Hippocampal Slices using a High-Density Multi-Transistor Array (Neurochip)

Lakshmi Channappa, Günther Zeck¹

Natural and Medical Sciences Institute at the University of Tübingen, Neurochip Research Group, Markwiesenstr. 55, 72770 Reutlingen, Germany

Hippocampal slice cultures afford the opportunity to investigate epilepsy in vitro over extended time periods, which may mimic the process of epileptogenesis observed with in vivo animal models [1]. The electrical imaging of local field potentials in organotypic hippocampal slices using high-density multi-transistor array of 16,384 sensors (1mm²) has been reported recently [2]. However, the participation of single units was not investigated.

Here we aim for simultaneous recording of single unit activity and local field potentials under conditions that induce epileptiform activity. We therefore extended the previously reported system to continuous recording at high temporal resolution (6 kHz). The experiments were performed on hippocampal slice cultures prepared from newborn SD rats (P6-P8). Transverse sections (400µm) were first cultured on membrane inserts [3].

Local field potentials and single unit activity were recorded from different subfields (CA1 or CA3 or DG) between 4 to 14 DIV. The cultured slices were tightly interfaced to the neurochip's recording array. Epileptiform activity was either elicited by omitting Mg²⁺ from the ACSF and elevating K⁺ concentration or by the addition of bicuculline methiodide.

Single units were detected mainly from the pyramidal cell layer of CA3. The identification of single units was aided by the high spatial resolution (7.4 µm) of the recording array. Simultaneously the propagation of local field potentials across the hippocampal subfields was imaged. Our preliminary results indicate that the activity of some units was inhibited by the emerging LFPs while other units started to increase firing frequency at the LFP onset.

The analysis of ensembles of single neurons during seizure-like events in hippocampal slice cultures may reveal mechanisms responsible for this disease.

[1] Ziobro JM, Deshpande LS, DeLorenzo RJ (2010) Brain Res. 1372: 110-120.

[2] Hutzler, Lambacher, Eversmann, Jenkner, Thewes, Fromherz (2006) J. Neurophysiol., 96, 1638-1645

[3] Stoppini L, Buchs PA, Muller D. (1991) J Neurosci Methods. 37(2):173-82.

Supported by the German Federal Ministry of Education and Research (BMBF grant 0312038)

Characterization of Kir4.1 channel expression in Schwann cells of the sciatic nerve in a mouse model of metachromatic leukodystrophy

Cin-He Chang, Lihua Wang-Eckhardt², Matthias Eckhardt², Gerald Seifert¹, Volkmar Gieselmann², Christian Steinhäuser¹

¹Institute of Cellular Neurosciences and ²Institute of Biochemistry and Molecular Biology, Medical Faculty, University of Bonn, Germany

Metachromatic leukodystrophy (MLD) is a lysosomal storage disorder caused by deficiency of arylsulfatase A (ASA) and altered sulfatide storage. ASA-deficient (ASA^{-/-}) mice are an animal model for MLD, however, they show only a relatively mild phenotype. An improved MLD mouse model has recently been generated that displays increased sulfatide storage in neural cells of the brain and peripheral nervous system. In the peripheral nerves of those mice, hypo- and demyelination was observed, leading to a slowed propagation of action potentials (Ramakrishnan et al., J Neurosci 27: 9482-9490). In addition, analysis of transcript and protein expression revealed an upregulation of the inwardly rectifying K⁺ channel subunit Kir4.1 which in the nervous system is expressed solely by glial cells. To investigate whether these changes are accompanied by alterations in Kir4.1 channel function, we applied the patch-clamp technique to Schwann cells freshly isolated from sciatic nerves of ASA^{-/-} mice, ASA^{-/-} mice overexpressing the sulfatide synthesizing cerebroside sulfotransferase (CST) (CST-tg/ASA^{-/-} mice), and wildtype littermates (WT) (12-20 months old).

Schwann cells from WT and ASA^{-/-} mice displayed depolarized membrane potentials (-39.0 ± 24.0 mV, $n = 15$ and -48.3 ± 10.3 mV, $n = 10$) and a high input resistance ($1,538.8 \pm 861.4$ MO, $n = 15$ and 938.7 ± 329.4 MO, $n = 10$, respectively). In contrast, Schwann cells from CST-tg/ASA^{-/-} mice displayed more negative resting potentials (-66.4 ± 12.7 mV, $n = 7$) and a much lower input resistance (247.6 ± 179.4 MO, $n = 7$). These findings indicate significant expression of functional Kir channels in Schwann cells of CST-tg/ASA^{-/-} mice, but not in WT or ASA^{-/-} mice. In line with this assumption, neither WT nor ASA^{-/-} mice displayed Ba²⁺-sensitive (100 μ M) inward currents at negative membrane potentials, while such currents were clearly present in Schwann cells from CST-tg/ASA^{-/-} mice. In conclusion, our results suggest that in the MLD mouse models, upregulation of Kir4.1 mRNA and protein levels in peripheral nerves is accompanied by increased expression of functional channels. Further studies are needed to understand the link between Kir channel expression by Schwann cells and the pathogenesis of MLD.

Funded by the DFG (SFB/TR3) and the European Community (FP7-202167 NeuroGLIA).

Mitochondrial dysfunction in a mouse model of Parkinson's disease

Julia Zerle, Florian Giesert¹, Martin Jastroch², Daniela Vogt-Weisenhorn¹, Wolfgang Wurst^{1,3,4}

¹Helmholtz Zentrum Munich, Institute of developmental genetics, Munich / Neuherberg, Germany

²Helmholtz Zentrum Munich, Institute of Diabetes Research Munich / Neuherberg, Germany

³Max Planck Institute of Psychiatry, Munich, Germany

⁴Technical University Munich, Germany

Parkinson's disease (PD) is a neurodegenerative disorder caused by the progressive loss of dopaminergic neurons in the substantia nigra accompanied by the appearance of Lewy bodies. According to recent findings the death of dopaminergic neurons is associated with mitochondrial dysfunction, oxidative stress, abnormal protein accumulation and protein phosphorylation. In this study we are concentrating on the contribution of the PD associated gene *LRRK2*, which displays autosomal dominant inheritance and late onset of PD. This gene codes for a huge multidomain protein including a GTPase domain and a kinase domain. *LRRK2* function has been implicated in modulation of the cytoskeleton, regulation of synaptic transmission and lately also in mitochondrial impairment. In our study we investigate on possible pathogenic mechanisms induced by human pathogenic mutations. In order to do so we are analysing primary neurons derived from a conditional R1441C knock-in mouse model, which exhibits a disease causing point mutation within the GTPase domain. In addition this mouse model gives us the opportunity to eliminate conditionally exon 31 and thus rendering the GTPase domain dysfunctional. Initially we focused on mitochondrial trafficking associated with cytoskeletal transport. We found significant velocity differences in the mitochondrial transport of heterozygous R1441C cortical neurons when compared with neurons from wildtype littermates. Acute knockdown of *Lrrk2* resulted in the same phenotype, whereas neurons of a knockdown mouse model this phenotype is abolished, possibly due to compensatory effects. The underlying molecular mechanisms of these trafficking phenotypes could be attributed to defective acetylation of the cytoskeleton and/or mitochondrial dysfunction per se. In preliminary experiments acetylation of microtubules seems not to be affected, however, first indications hint towards a dysfunctional mitochondrial respiration. Taken together, the human pathogenic mutation R1441C within the *Lrrk2* gene has a direct effect onto mitochondria trafficking possibly due to defective mitochondrial respiration.

β -Synuclein aggregates and induces neurodegeneration in adult rat dopaminergic neurons in vivo

Grit Taschenberger, Johan Toloe¹, Yuliya Tereshchenko¹, Mathias Baehr¹, Sebastian Kuegler¹

¹Center Molecular Physiology of the Brain (CMPB) at University Medicine Göttingen, Dept. of Neurology, Germany

Alpha-synuclein gene multiplications, mutations and polymorphisms are causally linked to the pathogenesis of Parkinson's disease (PD), and fibrillar alpha-synuclein is the major component of Lewy bodies, the proteinous aggregations characteristic for PD. While the contribution of alpha-synuclein to neurodegeneration in PD is well accepted, a potential pathological impact of its close homologue, beta-synuclein, is enigmatic. Beta-synuclein is widely expressed throughout the central nervous system of humans and rodents and localized in nerve terminals as is alpha-synuclein, but the physiological functions of both proteins remain unknown. Recent findings supported the view that beta-synuclein can act as an ameliorating regulator of alpha-synuclein-induced neurotoxicity, having neuroprotective rather than neurodegenerative capabilities, and being non-aggregating due to absence of most part of the aggregation-promoting non-Abeta component (NAC) domain. However, there is small but growing evidence that beta-synuclein can aggregate under certain conditions. Further two mutations in the beta-synuclein gene are associated with Dementia with Lewy Bodies (DLB).

As animal model for the neurodegeneration in PD, we used targeted overexpression of alpha-, beta-, or gamma-synuclein in the substantia nigra of rats by means of recombinant adeno-associated viral vectors.

Supporting the hypothesis that beta-synuclein can act as a neurodegeneration-inducing factor we now demonstrate that wild-type beta-synuclein is neurotoxic for cultured primary neurons. Furthermore, beta-synuclein formed proteinase K resistant aggregates in dopaminergic neurons in vivo, leading to pronounced and progressive neurodegeneration in rats. Expression of beta-synuclein caused mitochondrial fragmentation, but this fragmentation did not render mitochondria non-functional in terms of ion handling and respiration even in late stages of neurodegeneration. A comparison of the neurodegenerative effects induced by alpha-, beta-, and gamma-synuclein revealed that beta-synuclein was eventually as neurotoxic as alpha-synuclein for nigral dopaminergic neurons, while gamma-synuclein proved to be non-toxic and had very low aggregation propensity. Our results suggest that the role of beta-synuclein as a putative modulator of neuropathology in aggregopathies like PD and DLB needs to be revisited.

Differential alterations in neuronal network excitability and behavior in mice with cell type-specific expression of RNA-edited glycine receptor $\alpha 3L$

Jochen Christian Meier, Nicola Maggio², Gürsel Caliskan³, Joanna Fedun⁴, Ute Häussler⁵, Sarah Kowalczyk⁶, Luminita Stoenica⁷, Ewa Chronowska⁸, Birthe Smolinsky⁶, Günter Schwarz⁶, Tamar Dugladze⁴, Gidi Rechavi², Uwe Heinemann³, Carola A. Haas⁵, Tengis Gloveli⁴, Akos Kulik⁸, Aline Winkelmann¹

¹RNA editing and Hyperexcitability Disorders Helmholtz Group, Max Delbrück Center for Molecular Medicine, 13092 Berlin, Germany

²The Chaim Sheba Medical Center, 56621 Tel HaShomer, Israel

³Physiology and Pathophysiology of the Hippocampal Formation, Institute of Neurophysiology, Charité Universitätsmedizin Berlin, 10117 Berlin, Germany

⁴Cellular and Network Physiology Group, Institute of Neurophysiology, Charité Universitätsmedizin Berlin, 10117 Berlin, Germany

⁵Experimental Epilepsy Research, Dept. of Neurosurgery, Neurocenter, University of Freiburg, 79106 Freiburg Germany

⁶Institute of Biochemistry, University of Cologne & Center for Molecular Medicine 50674 Cologne, Germany

⁷Developmental Neurobiology, Max Delbrück Center for Molecular Medicine, 13092 Berlin, Germany

⁸BIOSS Centre for Biological Studies, University of Freiburg, D-79104 Freiburg, Germany

Deregulation of the balance between neuronal excitation and inhibition can cause disease. So far, pharmacological approaches try to restore the balance, for example by targeting ion channel function in epilepsy. However, epilepsy has remained an intractable disease because none of the available drugs prevent disease progression. Therefore, novel and genuine approaches are required to tackle a disease at the root. Indeed, an increasing number of studies identify alterations in gene transcription and RNA processing as potential genuine disease mechanisms. In this context, we generated a transgenic mouse line for cell-type specific expression of a disease-relevant RNA variant of the *GLRA3* gene product. Our study reveals a presynaptic function of RNA-edited glycine receptor (GlyR) $\alpha 3L$, which results in different phenotypes depending on whether it is expressed in glutamatergic or GABAergic neurons. Mice with Camk2a-dependent receptor expression are hyperexcitable and suffer from increased seizure burden as well as severe impairment of memory performance, whereas mice with Pvalb-dependent expression do not show alterations in network excitability or cognitive function but suffer from anxiety. Thus, RNA editing of GlyR $\alpha 3L$ can be part of an intrinsic gene-regulatory mechanism of disease and a starting point for new therapeutic concepts.

Computational characteristics of recurrent neural networks under the influence of Alzheimer's disease

Claudia Bachmann, Tom Tetzlaff¹, Susanne Kunkel^{1,2}, Philipp Bamberger², Abigail Morrison^{1,2,3}

¹Jülich Research Center, Inst. of Neuroscience and Medicine (INM-6), Jülich, Germany

²Bernstein Center Freiburg, Albert-Ludwigs University, Freiburg, Germany

³Inst. of Cognitive Neuroscience, Faculty of Psychology, Ruhr University Bochum, Germany

Cognitive functions such as perception, memory, association, classification or prediction of dynamical systems can be realized by recurrent networks of simple model neurons [1,2,3]. In Alzheimer's Disease, there is a clear positive correlation between synapse loss and cognitive impairment [4]. However, the mechanisms underlying this correlation are so far poorly understood. Here, we investigate how the loss of excitatory synapses in sparsely connected random networks of spiking excitatory and inhibitory neurons [5] affects their dynamical and computational properties. By means of simulations, we study the network response to noisy realizations of multidimensional input spike-train templates. We observe that a loss of excitatory synapses on excitatory neurons (decrease in excitatory-excitatory indegree; vertical arrow in the figure) reduces the network's sensitivity to perturbations of time-varying input streams, improves its ability to generalize and impairs its discrimination capability [6]. Homeostasis, implemented as an up-scaling of the remaining excitatory-excitatory synapses to preserve the average firing rate, recovers the network performance (horizontal arrow in the figure). This provides a potential explanation for the delayed onset of clinical symptoms with respect to the onset of cortical damage: the performance of cortical networks only starts to drop when the homeostatic mechanisms are exhausted.

•

Supported by the Helmholtz Alliance on Systems Biology, the Helmholtz Association in the Portfolio theme "Supercomputing and Modeling for the Human Brain", the Jülich Aachen Research Alliance (JARA), the Next-Generation Supercomputer Project of MEXT, EU Grant 269921 (BrainScaleS), the Junior Professor Program of Baden-Württemberg and the Initiative and Networking Fund of the Helmholtz Association.

•

References:

1. Hopfield (1982), PNAS 79(8):2554–2558

2. Jaeger & Haas (2004), Science 304:78-80
3. Maass et al. (2004), Neural Computation 14:2531-2560
4. Terry et al. (1991), Ann Neurol 30(4):572-80
5. Brunel (2000), Comput Neurosci 8(3):183-208
6. Legenstein & Maass (2007), Neural Networks 20:323-334

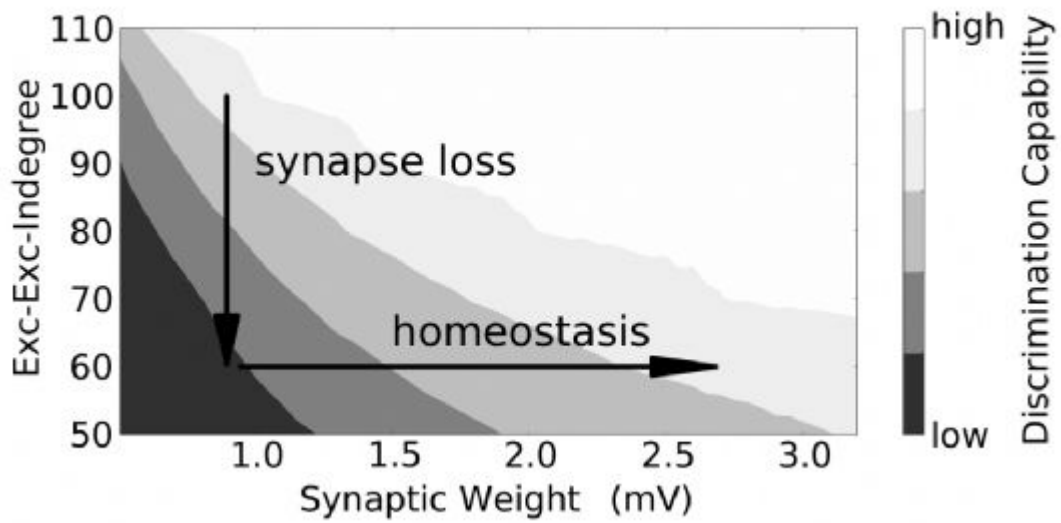

Poster Topic

T12: Neuroimmunology, Inflammation, and Neuroprotection

- T12-1A** Establishment of a retinal ischemia organ culture model
Sven Schnichels, Matthias Blak, Johanna Hofmann, KU Bartz-Schmidt, Martin S Spitzer, Maximilian Schultheiss
- T12-2A** Hypothermia protects retinal ganglion cells against ischemia
Maximilian Schultheiss, Mathias Blak, Tanja Dorfi, Johanna Hofmann, Karl Ullrich Bartz-Schmidt, Martin S. Spitzer, Sven Schnichels
- T12-3A** In vitro analysis of hippocampal and prefrontal cortex neuroinflammatory mechanisms involved in interferon-therapy and hepatitis C related depression
Carolina Hoyo Becerra, Anastasia Hübener, Martin Trippler, Lena Poggenpohl, Guido Gerken, Jörg Friedrich Schlaak
- T12-4A** Gene expression analysis of retinal ganglion cells in experimental autoimmune optic neuritis
Prateek Kumar prateek, Sven Wichert, Benedikt Kretzschmar, Mathias Bähr, Moritz Rossner, Katharina Hein
- T12-5A** Correlating Faces Symbol Test, Symbol Digit Modalities Test and Paced Auditory Serial Addition Test to white matter damage in Relapsing Remitting Multiple Sclerosis
Alina Freing, Michael Scheel, Nicholetta Weinges-Evers, Laura Wieder, Jan-Markus Dörr, Friedemann Paul, Alexander U. Brandt, Jens Wuerfel
- T12-6A** Erythropoietin-mediated protective mechanisms in insect neurons
Natasa Miljus, Karina Schäfer, Sarah Pompe, Mona Roesler, Hannelore Ehrenreich, Ralf Heinrich
- T12-1B** Systemic transplantation of neural precursor cells in experimental cerebral ischemia – dependence of functional outcome on cell delivery timing
Mohammad Rakibul Hasan, Mahesh Kumar Teli, Dirk M Hermann, Thorsten R Doeppner
- T12-2B** Autoimmune activities in an experimental model of retinal ganglion cell loss
Sandra Kühn, Rozina Noristani, Mathias Kühn, Burkhard Dick, Stephanie C. Joachim
- T12-3B** TGF β increases microglia-mediated engulfment of apoptotic cells via upregulation of the Itg β 5/Mfge8 receptor/ligand pair
Björn Spittau, Jennifer Rilka, Kerstin Krieglstein
- T12-4B** Autoimmune encephalitis: a search for novel neuronal autoantigens.

- T12-5B** Influence of Pigment Epithelium Derived Factor on Blood Brain Barrier in normal and ischemic brain
Arina Riabinska, Ryan Cordell, Menderes Yusuf Terzi, Marietta Zille, Melina Niemminen, Jan Klohs, Peter Vajkoczy, Ulrich Dirnagl, Ana Luisa Pina
- T12-1C** CD14 as a key regulator of TLR-mediated responses of microglia
Hana Janova, Tommy Regen, Denise van Rossum, Sandra Ribes, Roland Nau, Wolfgang Brück, Uwe-Karsten Hanisch
- T12-2C** Innate Immune anti-viral responses of IRF-1 in the CNS
Sharmila Nair, Katja Finsterbusch, Andrea Kroeger
- T12-3C** Functional characterization of the CDK5-dependent TRPV1 phosphorylation
Thomas Jendryke, Christian H. Wetzel
- T12-4C** Immunresponse against ocular tissues after immunizing rats with an optic nerve antigen
Stephanie C Joachim, Oliver W Gramlich, Panos Laspas, Sabrina Reinehr, Sandra Kuehn, Mathias Kuehn, Tischoff Iris, H Burkhard Dick, Franz H Grus
- T12-1D** Drawing Analogies Between Systems: The Role of MAGUK – Kv interactions in the Immune Synapse
Juliane Handschuh, Rebecca Pötschke, Carina Fürst, Martin Heine, Eckart Gundelfinger, Klaus-Dieter Fischer, Ulrich Thomas
- T12-2D** Interleukin-6 promotes axon regeneration of mature retinal ganglion cells and contributes to inflammatory stimulation-induced optic nerve regeneration
Marco Leibinger, Adrienne Müller, Philipp Gobrecht, Heike Diekmann, Anastasia Andreadaki, Dietmar Fischer
- T12-3D** Traumatic brain injury: Modulation of blood-brain barrier integrity by volatile anesthetics is influenced by the choice of volatile anesthetics on the level of tight junction protein expression
Christoph Michael Zehendner, Clara Luh, Eva-Verena Schaible, Ralph Timaru-Kast, Jana Hedrich, Heiko J. Luhmann, Kristin Engelhard, Serge C. Thal
- T12-4D** Induction of inflammatory demyelination causes retinal ganglion cell degeneration in experimental autoimmune encephalomyelitis
Heiko Schmid, Lioba Horstmann, Florian Kurschus, Ari Waisman, Burkhard Dick, Stephanie C. Joachim
- T12-5D** The astrocytic proteins NDRG2 and GFAP in the rat hippocampus are regulated by chronic social stress and the antidepressant citalopram
Gabriele Flügge, Carolina Araya-Callís, Christoph Hiemke

Establishment of a retinal ischemia organ culture model

Sven Schnichels, Matthias Blak¹, Johanna Hofmann¹, KU Bartz-Schmidt¹, Martin S Spitzer¹, Maximilian Schultheiss¹

¹Centre for Ophthalmology, University Eye Hospital, Schleichstr. 12/1, 72076 Tübingen, Germany

Ischemia plays an important role in several ophthalmologic diseases. Retinal Ganglion cells (RGCs) are the most sensitive cells to ischemia and are the first that die. To investigate neuroprotective agents and therapies against these ophthalmologic diseases we developed an easy-to use chamber for 6-well plates with inserts for organotypic cultures. We decided to use organotypic cultures, because in-vivo models or primary cultures are very time-consuming, expensive and several therapies or agents can not be tested in these models.

For this pilot-study, we incubated retinas at 37°C for different durations (45, 60 or 75, 90 and 120 minutes) under ischemic conditions. The chamber was streamed with N₂ for 5 minutes, then the chamber was immediately sealed and the retinas were incubated for the rest of the designated time. After the incubation the 6-well plate was removed from the chamber and left under a sterile bench with no lid for 2 minutes to adjust the air in the well plate to normal conditions. Next the 6-well plates were incubated for 24, 48 or 72 h in an incubator under standard conditions. To analyze the amount of RGCs and apoptotic RGCs, the retinas were frozen and processed for cutting. RGCs immunohistology was performed with a Brna3a-antibody. Apoptotic cells were visualized via TUNEL-staining and overall cell amount via DAPI-staining. Cells were counted manually.

We observed a time-dependant decrease in the amount of RGCs after 24, 48 or 72h, respectively. Moreover, we also observed an ischemia duration dependant decrease in the amount of RGCs. Furthermore the amount of TUNEL-positive cells was ischemia duration- and time-dependant. The damage to the RGCs trough 75 minutes of ischemia was comparable to the amount of damage by 1mM Glutamate incubation for 24h (20.27 vs. 19.69) and 48h (13.41 vs. 14.41). In contrast, in glutamate treated retinas, only few apoptotic RGCs were found.

In conclusion, we successfully established a cheap, reliable, reproducible, ease-to-use organotypic culture model for retinal ischemia. Any therapy can now be tested under ischemic organotypic conditions.

Hypothermia protects retinal ganglion cells against ischemia

Maximilian Schultheiss, Mathias Blak¹, Tanja Dorfi¹, Johanna Hofmann¹, Karl Ullrich Bartz-Schmidt¹, Martin S. Spitzer¹, Sven Schnichels¹

¹Centre of Ophthalmology, University Eye Hospital Tuebingen, Department of Ophthalmology, Schleichstr.12, 72076 Tuebingen, Germany

Hypothermia has been shown to be neuroprotective in the therapy of ischemic stroke. Furthermore the retina is easily accessible to induce hypothermia in an acute onset of ischemia like during central retinal artery occlusion. By using a cooled irrigation solution during Pars Plana Vitrectomy the retina could be easily cooled down for a certain timespan. Nevertheless the best temperature for cooling the retina is so far unknown.

To investigate neuroprotective agents and therapies like hypothermia we developed an easy-to use chamber for 6-well plates with inserts for organotypic cultures (Poster of Schnichels S).

To determine the optimal neuroprotective temperature we incubated retinas at 10, 20, 30 and 37°C for 75 minutes under ischemic conditions. Hypothermia was induced for 4 hours (h) and the ischemia chamber was cooled previously to the experiments. Hypothermia started with the onset of ischemia. For inducing ischemia the chamber was streamed with N₂ for 5 minutes, then the chamber was immediately sealed and the retinas were incubated for the rest of the designated time of ischemia. After the incubation the 6-well plate was removed from the chamber and left under a sterile bench with no lid for 2 minutes to adjust the air in the well plate to normal conditions. Afterwards the 6-well plate was continued to be cooled. Next the 6-well plates were incubated for 24 and 48 h in an incubator under standard conditions. To analyze the amount of RGCs and apoptotic RGCs, the retinas were frozen and processed for cutting. RGCs immunohistology was performed with a Brna3a-antibody. Apoptotic cells were visualized via TUNEL (Terminal deoxynucleotidyl transferase mediated dUTP Nick End Labeling)-staining and overall cell amount via DAPI (4',6-diamidino-2-phenylindole)-staining. Cells were counted manually.

We observed a temperature-dependant decrease in the amount of RGCs after 24 and 48 h, respectively. Moreover, we also observed an ischemia duration dependant decrease in the amount of RGCs. Furthermore the amount of TUNEL-positive cells was ischemia and temperature dependant.

In conclusion, hypothermia is neuroprotective to retinal ganglion cells against ischemia. Therefore by a cooled irrigation solution during Pars Plana Vitrectomy the tolerance time against ischemia could be increased by cooling the retina. Furthermore by cooled irrigation solution the retina could be protect during all kinds of Pars Plana Vitrectomy against iatrogenic or disease dependent damage.

In vitro analysis of hippocampal and prefrontal cortex neuroinflammatory mechanisms involved in interferon-therapy and hepatitis C related depression

Carolina Hoyo Becerra, Anastasia Hübener¹, Martin Trippler¹, Lena Poggenpohl¹, Guido Gerken¹, Jörg Friedrich Schlaak¹

¹University Hospital Essen, Gastroenterology and Hepatology, Hufelandstrasse, 55 (MFZ), 45122 Essen, Germany

BACKGROUND: We have previously identified 16 genes (DRIs) that are associated with the development of severe depressive side effects during the standard therapy with interferon alpha (IFN- α) and ribavirin in the peripheral blood of hepatitis C virus (HCV) infected patients. An enhanced expression of these genes was also found in psychiatric patients with severe depression and in autopsy brain tissue of suicidal individuals. Therefore, the present study focused on the effects of IFN- α and TLR3/HCV costimulation on the expression of the DRIs and inflammatory cytokines in a murine system. Neuronal plasticity, neurogenesis and apoptosis rates were also assessed as they may be related to the development of the depressive symptoms. The brain areas selected for the study were hippocampus (HP) and prefrontal cortex (PC), which are closely related to depression development.

METHODS: HP and PC neurons were isolated from E17 C57 BL/6 mice and cultured in neurobasal medium. For the gene expression study, neurons were stimulated at day 9 in vitro (div) using 1,000 IU of murine IFN- α (mIFN- α) and 100 μ g/ml of poly(I:C), and collected after 24 h. The expression of 10 DRIs, as well as IFN- α , IL-6, IP-10 and CCL5 was assessed using RT-PCR. In further experiments, neurons were treated with different concentrations of mIFN- α and poly(I:C). For the plasticity analysis, the neurons were stimulated at 4div during 24h and incubated with anti-MAP2 and anti-Tau1 O/N. For apoptosis analysis, neurons were stimulated at 4div during 72h and incubated with anti-caspase3 O/N. Alexa-labeled secondary antibodies were used for 1h. Additional Hoechst staining was applied. The Quick Cell Proliferation Assay kit was performed according to the manufacturer's instructions in neurons at 4div treated for 72h.

RESULTS: The stimulation with mIFN- α and Poly I:C promoted a significant upregulation of all cytokines in both brain areas. Regarding to the DRIs, differential responses were observed, ranging from a non- or mild response in one or both studied areas (i.e. Dynl1, showed a significant increase in PC but not in HP), to a strong upregulation, as found in Stat1, Rtp4, Gbp1 and Ube2L6. The proliferation assay revealed that neurogenesis is differentially affected in both studied areas, being HP much more sensible to the treatments than PC. Concomitantly, every treatment increased apoptosis levels in both studied tissues. Plasticity features, assessed by the length of dendrites and axons, were altered in all cases, showing that treatments reduce the development of neurites in a similar way in HP and PC.

CONCLUSIONS: Exposition of murine neurons of HP and PC to mIFN- α and poly(I:C) promotes an inflammatory reaction and an upregulation of DRIs. At physiological levels, the balance of neurogenesis vs. apoptosis and crucial plasticity features that are involved in the development and further maintenance of the neural network, appear to be altered. As suggested by our previous in vivo and ex vivo studies, the upregulation of selective DRIs, production of inflammatory cytokines and alterations in neuron viability and plasticity may be involved in the pathophysiological mechanisms underlying IFN-associated depression.

Gene expression analysis of retinal ganglion cells in experimental autoimmune optic neuritis

Prateek Kumar prateek, Sven Wichert², Benedikt Kretzschmar¹, Mathias Bähr¹, Moritz Rossner², Katharina Hein¹

¹University Medical Goettingen, Neurology, Robert-Koch-Str. 40, 37075 Goettingen, Germany

²Max Planck Institute for Experimental Medicine, Hermann-Rein-Str. 3, 37075 Goettingen, Germany

Optic neuritis is one of the most common clinical manifestations of Multiple Sclerosis (MS), an autoimmune inflammatory demyelinating disease of the CNS. Experimental autoimmune encephalomyelitis (EAE), the animal model of MS, induced by immunization with recombinant rat myelin oligodendrocyte glycoprotein (MOG) affects the optic nerve in 80–90% of female brown Norway (BN) rats. Previous studies in this animal model indicate that loss of retinal ganglion cells (RGCs), the neurons that form the axons of the optic nerve, occurs early and in part independent of the histopathological changes of the ON. Therefore, the aim of this study was to identify genes which are involved in the early phase of neuronal cell loss. Using laser capture microdissection we isolated intact RNA from unfixed RGCs and performed global transcriptome analysis of this cell type during the induction phase of the disease as well as in the clinically manifest MOG-EAE. In order to identify genes which are specific for autoimmune inflammation comparison gene expression analysis was performed in RGCs isolated from animals after ON axotomy. Our data implicates that at the induction phase of the disease genes involved in the immune dysregulation are overrepresented, whereas in the later stage of the disease genes that influence ion channel homeostasis are expressed. Moreover, we found that there is a relative absence of genes relevant to potential pathways for neurodegeneration independent of inflammation.

Correlating Faces Symbol Test, Symbol Digit Modalities Test and Paced Auditory Serial Addition Test to white matter damage in Relapsing Remitting Multiple Sclerosis

Alina Freing, Michael Scheel³, Nicholetta Weinges-Evers¹, Laura Wieder¹, Jan-Markus Dörr¹, Friedemann Paul^{1,4}, Alexander U. Brandt¹, Jens Wuerfel^{1,2,4}

¹NeuroCure Clinical Research Center, Charité University Medicine Berlin, Berlin, Germany

²Universitätsmedizin Göttingen, Abteilung Neuroradiologie, Robert-Koch-Straße 40, 37075 Göttingen, Germany

³Institute for Radiology and Neuroradiology, Charité – University Medicine Berlin, Berlin, Germany

⁴Experimental and Clinical Research Center, Charité University Medicine Berlin and Max Delbrück Center for Molecular Medicine, Berlin, Germany

Background: Clinical assessment of cognitive function in multiple sclerosis (MS) patients remains challenging. The widely used Paced Auditory Serial Addition Test (PASAT) as part of the Multiple Sclerosis Functional Composite (MSFC) is unpopular with patients and has proven difficult to use and interpret in longitudinal settings.

Objective: To evaluate the Symbol Digit Modalities Test (SDMT) and Faces Symbol Test (FST) in comparison to the PASAT using Tract-Based Spatial Statistics (TBSS) and to identify focal white matter damage associated with test performance in patients suffering from relapsing remitting multiple sclerosis (RRMS).

Methods: 72 patients with RRMS were enrolled. All patients received clinical and cognitive assessment including Expanded Disability Status Scale (EDSS), FST, SDMT and 3 second PASAT. All patients underwent diffusion tensor magnetic resonance imaging (MRI) at 1.5T. TBSS were calculated using FMRIB's FSL software package. Age and gender were corrected for.

Results: Fractional anisotropy (FA) was significantly reduced in patients with a lower FST and SDMT score, compared to those with a higher FST and SDMT score, respectively. When comparing FST with SDMT, FST differences corresponded to more wide spread white matter damage with foci in the occipital and parietal cortices.

Conclusion: FST and to a lesser degree SDMT corresponded to focal white matter damage in RRMS whereas PASAT did not in our cohort. Our results support replacing PASAT with either test for assessing cognitive function in RRMS.

Erythropoietin-mediated protective mechanisms in insect neurons

Natasa Miljus, Karina Schäfer¹, Sarah Pompe¹, Mona Roesler¹, Hannelore Ehrenreich², Ralf Heinrich¹

¹Georg August University Göttingen, Dept. of Cellular Neurobiology, Julia-Lermontowa-Weg 3, 37077 Göttingen, Germany

²Max-Planck institute for Experimental Medicine, Division of Clinical Neurosciences, Hermann-Rein-Strasse, 37077 Göttingen

Erythropoietin (EPO) initiates adaptive cellular responses to both moderate environmental challenges and tissue damaging insults in various non-hematopoietic mammalian tissues including the nervous system. EPO's neuroprotective and neuroregenerative functions are mediated through janus kinases (JAK) / signal transducers and activators of transcription (STAT) transduction pathways.

Homologs of the human EPO gene have been identified in various species including other mammals, amphibia and fish. Our recent studies on insects (Ostrowski et al., Neuroscience 188: 95-108, 2011) revealed similar neuroprotective and regenerative functions of EPO as described by numerous studies on mammalian nervous tissues. In particular, recombinant human EPO (rhEPO) increased the survival of primary cultured grasshopper brain neurons in a concentration dependent manner, accelerated neurite regeneration of these neurons and increased neuronal survival under hypoxia. rhEPO's protective effects on cultured grasshopper and *Drosophila* neurons under hypoxic conditions were abolished by the janus kinase inhibitor AG490, suggesting that the initiation of intracellular signalling cascades is similar in insects and mammals. Insect homologs of downstream components of signalling cascades that mediate EPO-induced neuroprotection in mammalian neurons (e.g. STATs and Akt) have been studied with respect to a similar function in insect neurons.

The results of our studies on EPO-mediated neuroprotection in insects parallel a large number of similar studies on mammalian nervous systems. This indicates that a ligand/receptor system with high structural and functional similarity to the mammalian EPO/EPO receptor system mediates neuroprotective and neuroregenerative effects in insects and probably also in other invertebrates. EPO-like signalling involved in tissue protection appears to be an ancient beneficial function shared by vertebrates and invertebrates.

Systemic transplantation of neural precursor cells in experimental cerebral ischemia – dependence of functional outcome on cell delivery timing

Mohammad Rakibul Hasan, Mahesh Kumar Teli¹, Dirk M Hermann¹, Thorsten R Doeppner¹

¹Department of Neurology, University Hospital Essen, Hufelandstrasse 55, 45147 Essen, Germany

The only causal therapy of ischemic stroke remains thrombolysis, which is limited due to its narrow time window and severe side effects. As such, transplantation of adult stem cells has evolved as a promising neuro-regenerative therapy for experimental stroke in rodents. However, presence of the blood-brain-barrier and an elevated immune response in the early ischemic brain are some of the obstacles to overcome in cell based therapy. Therefore, determination of the optimal time point for cell delivery after stroke onset is crucial. Here, we analyzed outcomes of mice that had received intravenous delivery of adult subventricular zone derived neural progenitor cells (NPC; 1×10^6 cells) either during reperfusion, on day 1 or on day 28 after stroke. We observed improved functional recovery of mice for up to 12 weeks post-stroke using multiple cell delivery time points. This finding was accompanied by increased fiber density in the corpus callosum and the contralateral striatum after anterograde tract tracer injection into the lateral motor cortex, suggesting enhanced post-ischemic neuroplasticity due to NPC transplantation. We also analyzed cell proliferation and cell differentiation rates within the ischemic brain as well as homing of grafted GFP-labeled NPCs at different reperfusion time points. Thus, our results may provide significant insight to determine the optimal therapeutic window for delivery of NPCs after ischemic stroke.

Autoimmune activities in an experimental model of retinal ganglion cell loss

Sandra Kühn, Rozina Noristani¹, Mathias Kühn¹, Burkhard Dick¹, Stephanie C. Joachim¹

¹Experimental Eye Research Institute, Ruhr University Eye Hospital, Bochum, Germany

Purpose: Immune cells were detected in retinae of glaucoma model. Glia cells and lymphocytes belong to these cell populations. Yet is unknown, if this both cell types having in direct effect to the retinal ganglion cells (RGCs). To clarify this question rats were immunized with ocular antigens such as optic nerve homogenate antigen (ONA) und S100, which led to an immune-mediated apoptosis of RGC in previous studies.

Methods: Rats were immunized with S100 and ONA (n=6). S100 is expressed by glia cells and RGC. Immunized groups were compared to NaCl injected group (Co, n=6). The intraocular pressure (IOP) was measured weekly. After 28 days the RGC and macroglia density was quantified using Brn-3a and GFAP double stained cryo-sections. The GFAP intensity was scored by ImageJ. Additionally, FasLigand (FasL), a member of tumor necrosis factor family, was detected together with Brn-3a on cryo-sections. After 14 days the lymphocytes T-cells and B-cells were analyzed in spleen, cervical lymph nodes, blood and retina (n=5) using Cyflow-FACS and compared to a Naïve group (untreated). Groups were compared with student t-test.

Results: After 28 days, a significant lower RGC density was detected in immunized groups in contrast to Co (S100: p=0.005; ONA: p=0.0005). There were no significant changes in the IOP (p=0.5). But a massive up regulation of GFAP in ONA group compared to Co (p=0.00003) was quantifiable. GFAP intensity in S100 group was not significantly higher than Co. The FasL was distributed across all retina cell layers and not up regulated in the immunized groups at 4 weeks. After 14 days a significant but minor T-cell population migrated in the retina of ONA compared to Naïve group (p=0.03). The T-cell number in the S100 retinae was not significant different to Naïve group. In the peripheral organs, no changes in T-cell and low changes in B-cell populations were noted.

Conclusions: RGC loss without variations in the IOP was triggered by the injection of ONA and S100 in this model. Macroglia activation was antigen-dependent, but these immune cells are likely not associated with FasL. T-cells overcame the blood-retina-barrier after immunization, while B-cells stayed systemically. Macroglia and autoimmune T-cells seem to play an antigen and time depend role in the course of RGC death. It is unknown, if T-cells participate in the first degeneration period. The role of macroglia in this later time point is equally outstanding; possibly they initiate a second degeneration phase.

Funding: German Research Foundation (DFG JO-886/1-1), FoRUM Program (Ruhr University Bochum)

TGF β increases microglia-mediated engulfment of apoptotic cells via upregulation of the Itg β 5/Mfge8 receptor/ligand pair

Björn Spittau, Jennifer Rilka¹, Kerstin Krieglstein^{1,2}

¹Albert-Ludwigs-University Freiburg, Institute for Anatomy and Cell Biology, Department of Molecular Embryology, Albertstraße 17, 79104 Freiburg, Germany;

²Albert-Ludwigs-University Freiburg, Freiburg Institute of Advanced Studies (FRIAS), Albertstraße 19, 79104 Freiburg, Germany

Apoptotic cells are rapidly engulfed by phagocytes in order to prevent the release of noxious factors as well as immunogenic material from dying cells. In the central nervous system (CNS), microglia serve as phagocytes and have important functions in clearing apoptotic cells and cellular debris to maintain neuronal networks. The opsonin milk fat globule-EGF factor 8 (Mfge8) has been described to bind phosphatidylserine residues at the outer membranes of apoptotic cells, thereby presenting an "eat-me" signal for microglia expressing the Mfge8 receptor Integrin β 5 (Itg β 5). Here we show that TGF β 1 increases the expression of the Itg β 5/Mfge8 receptor-ligand pair in microglia and, thus, promotes the phagocytosis of apoptotic cells. Using data from cDNA micro arrays and western blotting, we demonstrate that TGF β 1 treatment of microglia resulted in upregulation of Mfge8 and its receptor Itg β 5. Staurosporine-treated and fluorescently-labelled MN9D cells were used to analyse the extend of microglial phagocytosis after TGF β 1 treatment. TGF β 1 significantly increased the phagocytosis of apoptotic MN9D cells in BV2 cells and primary microglia. Moreover, we provide evidence that LPS-induced classical microglia activation is associated with downregulation of Mfge8. Together, our data introduce the receptor ligand pair Itg β 5/Mfge8 as novel TGF β 1 regulated genes in microglia and further underline the importance of TGF β 1 as a mediator of microglia functions during the resolution and regeneration phase of neuroinflammatory responses.

Autoimmune encephalitis: a search for novel neuronal autoantigens.

Margje Helena van Coevorden - Hameete, Esther de Graaf¹, Peter Maat², Esther Hulsenboom², Peter Sillevius-Smitt², Casper Hoogenraad¹

¹Universiteit Utrecht, Cell biology, Padualaan 8, 3584 CH Utrecht, Netherlands

²Erasmus MC, Department of Neurology, 's Gravendijkwal 230, 3015 CE Rotterdam, Netherlands

Paraneoplastic neurological syndromes (PNS) are rare, but usually severely disabling disorders. PNS can affect the peripheral as well as the central nervous system and can result in a wide range of symptoms from dermatomyositis to encephalitis. PNS is thought to be caused by an immune response which is triggered by the expression of neuronal antigens in a tumor. Usually these antigens are located intracellularly. The antibodies formed are thought to be non-pathogenic and more likely a biomarker of a cytotoxic T-cell response. These disorders do not respond to immunotherapy, but can sometimes be halted by effective oncological therapy. In recent years, a growing number of patients have been identified with autoimmune encephalitis in the presence of autoantibodies directed at synaptic proteins. In up to 70% of these patients no malignancies can be identified and the patient often presents with limbic encephalitis and seizures. In contrast with the intracellular antigen group, these patients do react to immune suppression.

Most of the antibodies in this patient group are found to be directed against the N-methyl D-aspartate receptor (NMDAR), and in smaller numbers against the AMPA receptor subunits (GLUR1 & GLUR2), the γ -amino-butyric acid-B receptor (GABAB-R) and more recently leucine-rich, glioma-inactivated 1 (LG11, previously attributed to voltage-gated potassium channels). However in many more autoimmune encephalitis patients we and others have tested the neuronal antigens remain to be identified. Antigen identification can lead to the development of diagnostic tests resulting in earlier disease recognition, faster treatment initiation and, as a result, a better outcome.

Our aim is to identify new antigens using immune-purification of rat brain extracts by patients' sera, followed by mass spectrometry (IP-MS). Serum and cerebral spinal fluid samples are selected from our serumbank based on the clinical description of limbic encephalitis in the absence of known antigens. Samples' reactivity to neuronal tissue is tested using rat brain slides and cultured hippocampal neurons. Sera leading to similar staining patterns will be compared to facilitate identification of the antigen among the data obtained by the IP-MS.

So far, in our hands, this method has been successful in the identification of Delta/Notch-like epidermal growth factor (EGF)-related Receptor (DNER) as the antigen recognized by sera of patients with subacute cerebellar ataxia associated with Hodgkin Lymphoma (HL) and a typical somato-dendritic punctate staining of neurons. Knock down of endogenous DNER in cultured hippocampal neurons abolished the sera's punctate staining pattern and depletion of the DNER antibodies from the serum resulted in absence of the punctate staining of rat cerebellar slices. Patients with ataxia and HL can now be screened quickly and reliably by using a DNER-cell-based screening assay.

This example demonstrates the strength of combining a good serological and clinical description with the use of IP-MS in identifying new autoantigens. To help diagnosis in limbic encephalitis patients and to get a better understanding of its pathogenic nature, this will be followed up by functional analysis of the identified antibodies and antigens.

Influence of Pigment Epithelium Derived Factor on Blood Brain Barrier in normal and ischemic brain

Arina Riabinska, Ryan Cordell¹, Menderes Yusuf Terzi¹, Marietta Zille², Melina Niemminen¹, Jan Klohs², Peter Vajkoczy¹, Ulrich Dirnagl², Ana Luisa Pina¹

¹Department of Neurosurgery and ²Experimental Neurology, Charité-Berlin Medical University, Berlin, Germany.

Pigment epithelium derived factor (PEDF) is a neurotrophic factor with diverse functional actions. Besides being a neurotrophic, neuroprotective, antitumorigenic and antiangiogenic agent, PEDF is an antipermeability agent. In the eye PEDF has been shown to decrease VEGF-induced Blood-Retina-Barrier permeability.

Selective permeability of the blood brain barrier (BBB) provides homeostasis, proper nutrition and protection of the brain from toxic substances and pathogens. Disruption of the BBB contributes to etiology of many neurological diseases including ischemic stroke. An uneven, wavelike pattern of post-ischemic BBB opening has been described in the scientific literature.

In our work we show that PEDF can prevent BBB disruption, artificially induced by VEGF, having performed intraparenchymal injections of these neurotrophic factors in the brain. We have characterized the time course of BBB opening in 1 hour MCAo mouse model and found highest extravasation volumes at 16 and 24 hours after stroke. We observed increase PEDF levels in the brain after MCAo by influx with blood at 12 and 24 hours and synthesis within the brain tissue at 8 and 16 hours after stroke. Intraventricular infusion of PEDF in mice with MCAo led to reduction of extravasation volumes by 24 hours after occlusion. Animals, treated with PEDF have also had significantly less oedema and smaller lesion volumes than vehicle-treated animals. Finally we could observe less apoptotic cells in the ipsilateral hemispheres of PEDF infused MCAo mice.

Taken together, we present PEDF as a brain vessel permeability inhibitor, which can possibly be involved into post-ischemic BBB disruption and could potentially antagonise it.

CD14 as a key regulator of TLR-mediated responses of microglia

Hana Janova, Tommy Regen², Denise van Rossum¹, Sandra Ribes¹, Roland Nau¹,
Wolfgang Brück¹, Uwe-Karsten Hanisch¹

¹Universitätsmedizin Göttingen, Neuropathologie¹, Robert-Koch Straße 40, 37075 Göttingen, Germany

²Institut für Molekulare Medizin
Universitätsmedizin der Johannes Gutenberg-Universität
Hochhaus am Augustusplatz, Geb. 905
Obere Zahlbacher Strasse 67
55131 Mainz
Germany

Microglia, a major myeloid cell population of the central nervous system (CNS), are equipped with a variety of receptors that enable them to sense infection as well as damage. Toll-like receptor 4 (TLR4) is well-known for the recognition of lipopolysaccharide (LPS), a cell wall component of Gram-negative bacteria. It signals via both MyD88- and TRIF-dependent signalling pathways, leading to the production of cytokines and chemokines and thereby also supporting the recruitment and activities of immune cells at the site of an insult. TLR4, however, does not act on its own but rather in a versatile complex with other co/receptors, such as CD14. Even though CD14 has been traditionally considered simply as a LPS affinity provider, recent data indicate that CD14 is also necessary for the endocytosis of TLR4, which links TLR4 to intracellular signalling via the TRIF adapter protein. Our findings now show that CD14 critically controls the magnitude and essentially shapes the profile of microglial cyto/chemokine production in response to diverse LPS variants. CD14 increases the sensitivity towards LPS in a cell type-specific manner, making microglia far more sensitive to LPS than bone marrow and peritoneal macrophages. Furthermore, CD14 absence in microglia triggers an excessive production of selected chemokines, such as the neutrophil chemoattractant CXCL1, resulting in a massive neutrophil infiltration into brains of mice infected by *E.coli*, suggesting that CD14 is crucial for avoiding hyper- as well hyporesponses. These regulatory activities of CD14 require its membrane insertion and prolonged functionality, pointing to an involvement of signalling. In order to reveal candidates for such signalling mechanisms, we tested the role of Syk and PLC. Even though these enzymes were described to play a role in CD14-dependent signalling in dendritic cells, they have no contribution in microglia, further pointing to a cell type-specific organization of the CD14/TLR4 complex in microglia. Importantly, we identified receptor systems that impose influences on CD14 expression itself which would thereby determine the extent and impact of a CD14-mediated regulation of TLR4 functions.

Innate Immune anti-viral responses of IRF-1 in the CNS

Sharmila Nair, Katja Finsterbusch¹, Andrea Kroeger¹

¹Helmholtz Centre for Infection Research, Innate Immunity and Infection, Inhoffenstr.-7, 38124 Braunschweig, Germany

Type I interferons (IFNs) are considered to be the universal mechanism by which viral infections are controlled. Their induction play critical roles in the expression of several anti-viral factors known as interferon stimulated genes (ISGs) which are essential to induce an anti-viral response. The Interferon regulatory factor (IRF) family of transcription factors are the master regulators of the innate immune signalling and have crucial antiviral roles in both the innate and adaptive immune responses. However, little is known about the induction and regulation of antiviral responses in the brain following infection. Here, we identify IRF-1 as a key player involved in regulating antiviral responses in the brain.

Challenge of IRF-1^{-/-} mice with a sub lethal dose of vesicular stomatitis virus (VSV), a neurotropic virus belonging to the same family as the rabies virus, made them very susceptible to neuro-pathogenesis. A comparison of viral replication in the peripheral organs and the CNS (brain) between the IRF-1^{-/-} and WT (C57BL/6) mice demonstrated that while WT type mice clear the virus from all the organs, the IRF-1^{-/-} mice failed to clear virus from the brain, indicating the unique role of IRF-1 for viral defenses in the brain. Although this transcription factor was initially implicated to be a regulator of the type I IFNs, notable differences of the Type I IFN induction in the brains of IRF-1^{-/-} and the WT mice were not visible post infection. Early antibody response is important to control VSV replication. Our results show an intact IgM and IgG antibody response post infection in the IRF-1^{-/-} mice. Additionally, our data also suggests that the susceptibility of IRF-1^{-/-} was not mediated by a defect in the T cell responses.

Collectively, our data suggest that IRF-1 responses protect against VSV infection through and IFN-independent program which is important, especially when viruses evade immunity by the inhibition of the IFN system.

Functional characterization of the CDK5-dependent TRPV1 phosphorylation

Thomas Jendryke, Christian H. Wetzel²

¹ Department of Cell Physiology, Ruhr-University Bochum, D-44780 Bochum

² Department of Psychiatry and Psychotherapy, University of Regensburg, D-93053 Regensburg

Temperature and chemical compounds are perceived by a variety of ion channels and receptors, in particular members of the transient receptor potential (TRP) ion channel family. TRPV1 as well as TRPA1 are well established nociceptors and it is supposed that, expressed in dorsal root ganglia neurons, these receptors initiate nociception. During inflammatory conditions, receptor activating and modulating factors are released. They sensitize primary afferent neurons of dorsal root ganglia that lead to hyperalgesia and allodynia. The inflammatory factors activate intracellular signaling pathways resulting in the sensitization of TRPV1 ion channels. Predominantly, the sensitization process depends on phosphorylation of TRPV1 by kinases like PKA, PKC and CAMKII. Moreover, Pareek et al. (2007) demonstrated in a mouse model that TRPV1 can also be phosphorylated by the cyclin-dependent kinase 5 (CDK5). Therefore, we developed a strategy to characterize the CDK5 dependent phosphorylation of TRPV1. To investigate the modulation more directly we performed electrophysiological experiments in a heterologous cell system. CHO cells transfected with cDNA coding for TRPV1 or co-transfected with TRPV1, CDK5 and the CDK5 activator P35, were challenged by application of capsaicin. Under Ca²⁺-free conditions, the presence of CDK5 and P35 induced a left-shift of the concentration/response-relationship, indicating sensitization of TRPV1 that is dependent on CDK5. Also TRPV1 single-channel events that were induced by depolarizing voltage-steps in outside out patches, point to a CDK5-dependent effect on single-channel kinetics. In presence of 2 mM CaCl₂, the repetitive application of 3.3 μM capsaicin induced a strong tachyphylaxis of TRPV1 that is delayed and reduced by co-expression of TRPV1, CDK5 and P35. In addition, we generated a TRPV1 T407A mutant to inhibit phosphorylation of TRPV1 at the CDK5 consensus site, and generated a T407D mutant to mimic the phosphorylation. A pharmacological and electrophysiological approach using these mutants will help to further characterize the effect of phosphorylation at position T407 and its effect on sensitization and tachyphylaxis. Taken together, these first data support the observation that TRPV1 is phosphorylated and sensitized by CDK5.

Immunresponse against ocular tissues after immunizing rats with an optic nerve antigen

Stephanie C Joachim, Oliver W Gramlich², Panos Laspas², Sabrina Reinehr¹, Sandra Kuehn¹, Mathias Kuehn¹, Tischoff Iris³, H Burkhard Dick¹, Franz H Grus²

¹Experimental Eye Research Institute, Ruhr University Eye Hospital, Bochum, Germany

²Experimental Ophthalmology, University Medical Center, Mainz, Germany

³Institute of Pathology, Ruhr University, Bochum, Germany

Purpose: Currently it is unknown if antibodies detected in patients with glaucoma are harmful to retinal ganglion cells (RGC) or trigger disease formation in any way. In a model of experimental autoimmune glaucoma RGC loss can be induced through immunization with ocular antigens.

Methods: Rats were injected with optic nerve homogenate (ONA) in Freund's Adjuvant (FA) and pertussis toxin (PTX). Animals of the control group (CO) received FA and PTX in NaCl. Serum from different study points was used to analyze autoreactive antibodies against retina or optic nerve. The antibody staining intensity was scored from 0 (no) to 3 (severe stain) on histologic slides. At 10 weeks RGC density was evaluated via retinal flatmounts and cross-sections. Additionally, optic nerves were checked for possible signs of demyelination and inflammation (LFB and H&E stain).

Results: A continuous increase of autoreactive antibodies against optic nerve and retina sections was observed. At 4, 6 and 10 weeks antibody levels were significantly higher in immunized animals ($p < 0.01$). The following mean levels were recorded at 10 weeks for retina: CO: 0.3 ± 0.1 ; ONA: 2.2 ± 0.2 ($p = 0.00001$) and optic nerve: CO: 0.3 ± 0.2 ; ONA: 2.7 ± 0.1 ($p = 0.00001$). Density of RGCs was significantly decreased in ONA animals ($p = 0.009$). Optic nerves of the ONA group showed no infiltrates, but a certain disruption in the organization of the myelin sheath.

Conclusions: Findings of this study support that antibodies may play a crucial role in events leading to apoptosis of RGCs. The slow dissolution of RGCs in animals with autoimmune glaucoma is comparable to slow progressive cell loss in glaucoma patients, thus making this a useful model to develop neuroprotective therapies.

Drawing Analogies Between Systems: The Role of MAGUK – Kv interactions in the Immune Synapse

Juliane Handschuh, Rebecca Pötschke¹, Carina Fürst², Martin Heine², Eckart Gundelfinger¹, Klaus-Dieter Fischer³, Ulrich Thomas¹

¹Leibniz Institute for Neurobiology, Neurochemistry, Brenneckestr. 6, 39118 Magdeburg, Germany ²LSA-FG Molecular Physiology, Leibniz Institute for Neurobiology, Brenneckestr. 6, Magdeburg, Germany ³Institute of Biochemistry and Cell Biology, Faculty of Medicine, Otto-von-Guericke University, Leipziger Str. 44, Magdeburg, Germany

Both chemical synapses in the nervous system and so-called immunological synapses (IS), which form between discrete cells in the immune system, utilize specific molecular recognition events, cell-cell adhesion, positional stability and directed signaling events as a basis for intercellular communication. Moreover, both types of synapses are strikingly dynamic involving molecular and structural rearrangements. Despite obvious differences, a comparison between both types of synaptic junctions, which have been studied from distinct angles, might be fruitful, e.g. by reciprocally adopting conceptual ideas. Along this line we have started to evaluate a multitude of neuronal synaptic proteins for their expression in human and murine lymphocytes. Among these are various membrane-associated guanylate kinases (MAGUKs), including hDlg (Dlg1, SAP97) and PSD-95 (Dlg4). As submembrane multidomain scaffolding proteins, MAGUKs are well known to organize the molecular architecture of neuronal synapses. Although expression of hDlg in immune cells has been documented previously, its mode of action with regard to the formation and function of the IS remains poorly understood. Voltage-gated potassium channels (Kv) are bona fide interaction partners of MAGUKs in neurons. In T-lymphocytes Kv1.3 is employed for sustaining the membrane potential required for Ca²⁺ influx during T Cell activation (TCA). We hypothesized, that hDlg is involved in the recruitment of Kv1.3 to the IS as a means to modulate the channel and thus the profile of TCA. We found, that hDlg localizes to the IS only during an initial phase of synapse formation, possibly reflecting a short-term delivery or pick-up function. To assess, how this temporal IS localization relates to the interaction of hDlg with Kv1.3, we have generated epitope- and fluorescently-tagged versions for either protein, which allow for single molecule tracking (Kv1.3 only), TIRF microscopy and/or FRET analysis. Moreover, based on (i) shRNA-mediated knock-down of hDlg and (ii) Kv1.3 versions incapable to bind hDlg we will assess the impact of the latter on Kv1.3 dynamics and hence TCA. Given the role of Kv1.3 as a potential drug target to block discrete subpopulations of T cells, our studies may contribute to a better understanding and treatment of T-cell-mediated autoimmune diseases including multiple sclerosis.

Interleukin-6 promotes axon regeneration of mature retinal ganglion cells and contributes to inflammatory stimulation-induced optic nerve regeneration

Marco Leibinger, Adrienne Müller², Philipp Gobrecht¹, Heike Diekmann¹, Anastasia Andreadaki¹, Dietmar Fischer^{1,2}

¹Heinrich-Heine-University of Düsseldorf, Department of Neurology, Merowingerplatz 1a, 40225 Düsseldorf, Germany

²University of Ulm, Department of Experimental Neurology, Albert-Einstein-Allee 11, 89081 Ulm, Germany

Mature retinal ganglion cells (RGCs) do not normally regenerate injured axons and undergo apoptosis after axotomy. Inflammatory stimulation (IS) in the eye, for instance induced by lens injury, transforms RGCs into an active regenerative state, protects these neurons from cell death and stimulates axon regeneration into the injured optic nerve. Ciliary neurotrophic factor (CNTF) and leukemia inhibitory factor (LIF) have been identified as key factors mediating these effects. Here, we report that interleukin-6 (IL-6), another member of the family of gp130 activating cytokines, is markedly induced in the retina upon optic nerve injury and IS. Genetic ablation of IL-6 in mice significantly reduced IS-mediated axon regeneration. IL-6 receptor was found to be expressed by RGCs and IL-6 application to primary mature RGCs in culture was neuroprotective and markedly increased neurite outgrowth in a JAK/STAT3 and PI3K/Akt dependent fashion. Similarly, IC7, a specific IL-6 receptor agonist, promoted neurite growth of RGCs. Moreover, IL-6 reduced myelin, but not neurocan mediated growth inhibition. Intravitreal application of IL-6 activated the JAK/STAT3 signaling pathway in RGCs in vivo and transformed RGCs into a regenerative state, enabling axon regeneration beyond the lesion site of the optic nerve. Thus, IL-6 contributes to IS-induced optic nerve regeneration and its disinhibitory effect adds another feature relevant for optic nerve regeneration to the functions of so far identified mediating factors. These findings may be meaningful for the development of novel strategies to improve axon regeneration in the CNS.

Traumatic brain injury: Modulation of blood-brain barrier integrity by volatile anesthetics is influenced by the choice of volatile anesthetics on the level of tight junction protein expression

Christoph Michael Zehendner, Clara Luh², Eva-Verena Schaible², Ralph Timaru-Kast², Jana Hedrich¹, Heiko J. Luhmann¹, Kristin Engelhard², Serge C. Thal²

¹University Medical Center of the Johannes Gutenberg-University Mainz, Institute of Physiology and Pathophysiology, Mainz, Germany

²University Medical Center of the Johannes Gutenberg-University, Department of Anesthesiology, Mainz, Germany

The blood-brain barrier (BBB) is a highly complex barrier that is precisely regulated by the interplay of many cell types e.g. pericytes, astrocytes, neurons, microglia and smooth muscle cells. This interdependence is known as the Neurovascular Unit. On the cellular level the BBB possesses a complex network of inter- and intracellular proteins that are essential for its sealing function. Here, tight junction proteins (TJ) have a key role. A major cause for high mortality after traumatic brain injury (TBI) is the evolution of cerebral edema which is initiated by disruption of the blood-brain barrier (BBB).

As anesthetic care is mandatory in patients suffering from severe TBI it may be important to elucidate the effect of different anesthetics on cerebral edema formation. TJ proteins such as zonula occludens-1 (ZO-1) and claudin-5 (cl5) play a central role for BBB stability.

In this study the influence of the volatile anesthetics sevoflurane and isoflurane on in vitro BBB integrity was investigated by quantification of the electrical resistance (TEER) in murine brain endothelial monolayers and in co-culture of the BBB maintaining many cell types of the Neurovascular Unit. Secondly brain edema and TJ expression of ZO-1 and cl5 were measured in-vivo after exposure towards volatile anesthetics in naïve mice and after controlled cortical impact (CCI). In-vitro endothelial monocultures displayed significantly reduced TEER values within 24 hours after exposure to both anesthetics. In BBB co-cultures that more closely mimic the neurovascular unit (NVU) volatile anesthetics had no impact on TEER. In line with the in-vitro co-culture data we did not observe any effect of anesthesia on brain water content and TJ expression in healthy mice. However, 24 hours after CCI brain water content increased significantly in mice treated with isoflurane compared to sevoflurane. On mRNA level ZO-1 expression was significantly higher in sevoflurane compared to isoflurane exposed CCI animals which may point to a beneficial effect on BBB integrity as brain water contents were found to be significantly lower in case the CCI animals were anesthetized with sevoflurane. Immunohistochemical analyses revealed prominent disruptions of ZO-1 at the cerebrovascular level, while cl5 impairment was sparse in the pericontusional area. However the choice of the anesthetics did not have an impact on ZO-1 or cl5 disruptions. In conclusion the study demonstrates that anesthetics are capable of modulating brain edema formation after experimental TBI. This effect may be attributed to modulation of BBB permeability by differential TJ protein expression. Therefore, selection of anesthetics may influence the barrier function and introduce a strong bias in basic experimental research on pathophysiology of BBB dysfunction. Future studies are needed to investigate adverse or beneficial effects of volatile anesthetics on patients at risk for cerebral edema.

Induction of inflammatory demyelination causes retinal ganglion cell degeneration in experimental autoimmune encephalomyelitis

Heiko Schmid, Lioba Horstmann¹, Florian Kurschus², Ari Waisman², Burkhard Dick¹,
Stephanie C. Joachim¹

¹Knappschaftskrankenhaus, Experimental Eye Reserach Institute, Bochum

²Institute for Molecular Medicine, University Medical Center of the Johannes Gutenberg University, Mainz

Purpose: Patients suffering from Multiple sclerosis (MS) often are also affected with optic nerve inflammation. In some cases a couple of these patients also are affected by permanent vision loss.

We investigated in an experimental autoimmune encephalomyelitis (EAE) mouse model of MS if retinal ganglion cell (RGC) death is correlated with optic nerve inflammation and neurodegenerative disorder of the animals and if there is a difference in the apoptosis rate between the EAE and control group.

Methods: C57BL/6 mice (N=8) were immunized with 100 µg MOG35-55-peptides in complete Freund's adjuvant containing Mycobacterium tuberculosis and Pertussis toxin. Control mice (N=9) were treated the same except that MOG35-55-peptide was replaced by NaCl. Mice were examined daily using a paralysis scoring system ranging from 0 (no signs) to 5 (complete paralysis). 23 days post-immunization, eyes were prepared for flatmounts and stained with Nissl. Additionally retina cross-sections and ON sections were stained with haematoxylin/eosin (H&E) and luxol fast blue (LFB). Inflammatory cell infiltration in longitudinal sections of the ON were evaluated using a scale ranging from 0 (no infiltration) to 4 (massive infiltration). Demyelination in longitudinal sections of the ON was evaluated in a similar way using a score from 0 (no demyelination) to 2 (strong demyelination). Immunohistochemistry was performed in retinal cross-sections of immunized and control animals using antibodies against Brn-3a, Caspase 3 and DAPI. Statistical analysis was performed using Student's t-test.

Results: MOG35-55 treatment lead to clinical EAE symptoms starting day at 8 and declining at day 18 with a peak 15 days post immunization. Induction of EAE caused a significant reduction of RGCs ($p < 0.001$). H&E staining showed a significant amount of cell-infiltration in optic nerves of EAE-mice ($p = 0.004$). The grade of infiltration correlated with the EAE-score level. LFB-staining showed a local, but not global, significant loss of myelin in all immunized mice but not in controls ($p = 0.008$). MOG immunized mice had intact retinal layers with no sign of degeneration of the retinal layers. Staining with Caspase 3 showed no difference in the counts of Caspase 3+ cells in the retinal ganglion cell layer of both MOG immunized and control animals.

Conclusion: MOG immunization causes optic neuritis and RGC loss but no degeneration of retinal layers after 23 days. Our results lead to the conclusion that individual severity of EAE is related with the severity of inflammation in the ON. Furthermore, there is no difference in activation of Caspase 3 between immunized and control animals at 23 days post immunization, but most likely at earlier time points. To get a better understanding of the mechanisms leading to RGC death, a series of earlier time points has to be investigated.

Support: Mercator-Stiftung

The astrocytic proteins NDRG2 and GFAP in the rat hippocampus are regulated by chronic social stress and the antidepressant citalopram

Gabriele Flügge, Carolina Araya-Callís^{1,2}, Christoph Hiemke³

¹German Primate Center, AG Fuchs, Kellnerweg 4, 37077 Göttingen, Germany

²DFG Research Center for Molecular Physiology of the Brain, Göttingen, Germany

³Department of Psychiatry and Psychotherapy, University Medical Center Mainz, Mainz, Germany

Major depression may be related to alterations in brain glia. To investigate central nervous pathological changes which may lead to depression we used an established preclinical model, chronic social stress in male rats [1]. Expression of two proteins that are present in astrocytes, the cytoplasmic protein NDRG2 (n-myc down-regulated gene 2) and the intermediate filament protein GFAP (glial fibrillary acidic protein) was analyzed in the hippocampus of rats that had been submitted to daily social stress for five weeks. In addition, we determined effects of a chronic treatment with the antidepressant citalopram (CIT) which was given to the stressed rats via the drinking water during four weeks (30 mg/kg body weight/day).

Immunocytochemistry confirmed that NDRG2 is expressed in astrocytes but not in neurons. Quantitative Western blots showed that the chronic stress increased NDRG2 protein in the hippocampal formation. CIT did not prevent the upregulation but instead, upregulated NDRG2 expression in the non-stressed animals. GFAP expression in the hippocampus was downregulated by chronic stress and again, CIT did not counteract this effect. In contrast to the glial proteins, the stress-induced enhancement in the expression of the neuronal proteins SNAP-25 (synaptosomal-associated protein 25) and syntaxin-1A was prevented by CIT.

The present findings coincide with results from post mortem studies on cortical material from human patients with major depression where GFAP immunoreactivity was reduced [2]. Also chronic social stress in male tree shrews reduced GFAP immunoreactivity as shown in a previous study [3]. The stress-induced upregulation of the cytoplasmic protein NDRG2 together with the GFAP downregulation indicates that the cells undergo profound metabolic changes. Previous studies by others had shown that NDRG2 expression is positively regulated by glucocorticoids while GFAP expression is negatively regulated by these steroids [4]. Reduced expression of the glial intermediate filament protein may reflect the presence of resting astrocytes since GFAP is upregulated in reactive astrocytes [5].

One may speculate that these astrocytic processes contribute to protective mechanisms that support neuronal functioning. The finding that CIT failed to counteract the astrocytic reactions while the stress-induced changes in two neuronal proteins were prevented by the SSRI indicates that the stress-mediated protective mechanisms evoked in astrocytes dominate the actions of the antidepressive drug. Moreover, it appears that in the present experimental set-up, the therapeutic effects achieved during the four-week treatment with CIT were due to effects on neuronal rather than astrocytic gene expression.

This work was funded by the Deutsche Forschungsgemeinschaft through the DFG Research Center 103, Molecular Physiology of the Brain (CMPB).

References

- [1] Rygula R, Abumaria N, Flügge G, Hiemke C, Fuchs E, Rüter E, Havemann-Reinecke U: *Behav Pharmacol* 17: 19-29, 2006.
- [2] Ongur D, Drevets WC, Price JL: *Proc Natl Acad Sci U S A* 95: 13290-13295, 1998.
- [3] Nichols NR: *Ann N Y Acad Sci* 1007: 349-356, 2003.
- [4] Czeh B, Simon M, Schmelting B, Hiemke C, Fuchs E: *Neuropsychopharmacology* 31: 1616-1626,

2006.

[5] Araya-Callís C, Hiemke C, Abumaria N, Flügge G: Psychopharmacology (Berl) 224: 209-222 (open access), 2012.

Poster Topic

T13: Cognitive, Emotional, Behavioral State Disorders and Addiction

- T13-1A** The 5-HT₆ receptor agonist EMD 386088 reverses ketamine-induced cognitive inflexibility in rats.
Agnieszka Nikiforuk, Piotr Popik
- T13-2A** Neuroanatomical characterization of a pharmacologically induced rodent model of schizophrenia.
Linda Reimers, Ana Relo, Corinna Klein
- T13-3A** ErbB4 modulates attention by controlling synaptic functions in the reticular nucleus of the thalamus
Sandra Ahrens, Santiago Jaramillo, Hiroki Taniguchi, Josh Z Huang, Bo Li
- T13-4A** Relationship between impulsivity, tobacco status and symptomatology in paranoid schizophrenia
Mounir Ouzir, Jean Michel Azorin, Nadia Correard, Sara-Nora Elissalde, Romain Padovani, Omar Battas, Driss Boussaoud
- T13-5A** Diras2: Candidate Gene for ADHD and its Expression in the Brain
Lena Weißflog, Nils Becker, Klaus-Peter Lesch, Andreas Reif
- T13-6A** (A)social behavior and sexual preference in mice lacking Tryptophan Hydroxylase 2
Daniel Beis, Valentina Mosienko, Karolin Holzwarth, Catherine Schweppe, Markus Wöhr, Natalia Alenina
- T13-1B** Deficits in trace fear memory in a mouse model of the schizophrenia risk gene TCF4
Moritz J Rossner, Magdalena M Brzozka
- T13-2B** Association study of the polymorphisms of selective genes and major depressive disorder: a patient centered approach
Jan Lehotsky, Andrea Evinova, Igor Ondrejka, Dusan Dobrota
- T13-3B** The Evolution of the Extended Amygdaloid Complex in Teleost Fish – Lessons from the Zebrafish Transgenic Lines tg(*vglut2a*:GFP) and tg(*lhx2a*:GAP-YFP)
Thomas Mueller, Nicola Sebert
- T13-4B** Truncated Disrupted in Schizophrenia 1 impairs cortical fast-spiking interneuron function and gamma oscillations
Jonas-Frederic Sauer, Michael Strüber, Marlene Bartos

- T13-5B** Electroconvulsive therapy in an animal model of depression
Wiebke Theilmann, Katarzyna Socala, Claudia Brandt, Helge Frieling, Stefan Bleich, Wolfgang Löscher
- T13-6B** Effect of deep brain stimulation in rats selectively bred for deficient prepulse inhibition, an endophenotype for Tourette`s syndrome
Svilen Delchev Angelov, Joachim K. Krauss, Kerstin Schwabe
- T13-1C** An acute MK801-induced schizophrenia-like psychotic episode is followed by chronic and persistent deficits in hippocampal long-term potentiation and memory in freely moving rats
Valentina Wiescholleck, Denise Manahan-Vaughan
- T13-2C** Metabolite changes during treatment of ADHD children with atomoxetine and methylphenidate measured using proton magnetic resonance spectroscopy
Dušan Dobrota, Veronika Husarova, Michal Bittsansky, Igor Ondrejka, Hubert Polacek
- T13-3C** The Role of NRG1 in cortical development and network integrity
Tilmann Unterbarnscheidt, Maria Clara Soto-Bernardini, Viktorija Velanac, Sophie Crux, Klaus-Armin Nave, Markus H. Schwab
- T13-4C** Behavioral consequences of early life stress and early life enrichment in CD1 mice
Antonia Post, Sandy Popp, Ulrich Dischinger, Aet Alttoa, Andreas Reif
- T13-5C** Analysis of the influence of odor stimulation with izoamilacetate on the psychophysiological state of human
Iuliia Sosiedka, Sergii Tukaiev , Sergii Krizhanovskiy, Igor Zima, Olga Radchuk
- T13-6C** Vision loss after peripheral optic nerve lesion is related to permanent alteration of long-range cortical functional connectivity: an EEG resting state study
Michal Bola, Carolin Gall, Christian Moewes, Anton Fedorov, Hermann Hinrichs, Bernhard A. Sabel
- T13-7C** Regional and cellular expression pattern of Cadherin-13 in the murine brain
Sarah Andrea Sich, A. G. Schmitt, K.-P. Lesch, O. Rivero
- T13-1D** Lifelong *Tph2* deficiency results in hyperactivity and altered emotional behavior
Jonas Waider, Sandy Popp, Florian Proft, Lise Gutknecht, Esther Asan, Klaus-Peter Lesch
- T13-2D** Metabolic imaging after noise trauma in tinnitus versus non-tinnitus conditions
Florian Theden, Sara Euteneuer, Dietmar Kuhl, Claudia Mahlke
- T13-3D** Stress suppresses monoaminergic neuromodulation of hippocampal inhibition
David Gruber, Kate Elizabeth Gilling, Anne Albrecht, Oliver Stork, Uwe Heinemann, Joachim Behr
- T13-4D** Topographic variability of language sites across time
Dieter M. Weinert, Eduard Kraus

T13-5D Cocaine-induced circuitry reorganization
Anna Suska, Brian R. Lee, Yan Dong, Oliver Schlüter

T13-6D The lateral habenula: Small nuclei with large effect on depression?
Anne Stephanie Vogel, Miriam A. Vogt, Natascha Pfeiffer, Mazahir T. Hasan, Rolf Sprengel, Peter Gass

The 5-HT₆ receptor agonist EMD 386088 reverses ketamine-induced cognitive inflexibility in rats.

Agnieszka Nikiforuk, Piotr Popik¹

¹Institute of Pharmacology, Polish Academy of Sciences, Department of Behavioral Neuroscience and Drug Development, 12 Smetna street, 31-343 Kraków, Poland¹

Preclinical data suggest that the 5-HT₆ (5-hydroxytryptamine-6, serotonin-6) receptor may represent a potential target for developing new therapies for treating cognitive dysfunctions in schizophrenia and other central nervous system disorders. Recent evidence indicates that not only blockade, but also activation of 5-HT₆ receptors exerts pro-cognitive effects. Nevertheless, little is known about the potential effectiveness of 5-HT₆ receptor agonists in animal models of schizophrenia-like cognitive deficits.

Schizophrenic patients exhibit frontal-like deficits including reduced flexibility in modifying behaviour in response to altering relevance of stimuli. Cognitive flexibility may also be assessed in rodents in the attentional set-shifting task (ASST). In this paradigm, rats must select a bowl containing a food reward based on the ability to discriminate the odours and the media covering the bait. The ASST requires rats to initially learn a rule and form an attentional "set" within the same stimulus dimensions, like the media (e.g., plastic balls, sawdust, pebbles, etc) covering the bait. At the extra-dimensional (ED) shift stage, the crucial phase of the task, animals must switch their attention to a new, previously irrelevant stimulus dimension and, for example, discriminate between the odours (e.g., arrack, lemon, orange, etc) and no longer between the digging media. The animals' performance at the ED phase is impaired in N-methyl-D-aspartate receptor (NMDAR) antagonist (e.g., phencyclidine or ketamine)-treated animals, regarded as pharmacological model of schizophrenia-like symptoms.

The aim of the present study was to evaluate the effect of the 5-HT₆ receptor agonist, EMD 386088, on the ketamine-induced deficits in the ASST task in rats.

Ketamine (30 mg/kg) was administered intraperitoneally (IP) to male Sprague-Dawley rats once daily for 10 consecutive days. The ASST was performed 14 days following the final drug administration. EMD 386088 (2.5 and 5 mg/kg, IP) was administered immediately prior to the testing.

Repeated ketamine administration significantly and specifically impaired rats' performance at the ED stage of ASST as indicated by an increased number of trials to criterion during this phase. Acute administration of EMD 386088 (2.5 and 5 mg/kg) reversed the ketamine-induced deficit in ED set-shifting performance.

Present study demonstrated the efficacy of the 5-HT₆ agonist in ameliorating cognitive deficits relevant to the psychopathology of schizophrenia. It thus seems likely that the activation of 5-HT₆ receptors may represent a useful pharmacological approach for cognitive enhancement in schizophrenia.

Acknowledgements

This study was supported by project "Prokog" UDA-POIG.01.03.01-12-063/09-00 "Antagonists of 5-HT₆ receptor as advanced antipsychotic drugs with pro-cognitive properties" co-financed by European Union from the European Fund of Regional Development (EFRD).

Neuroanatomical characterization of a pharmacologically induced rodent model of schizophrenia.

Linda Reimers, Ana Relo¹, Corinna Klein¹

¹AbbVie Deutschland, Neuroscience Discovery Research, Knollstraße, 67061 Ludwigshafen am Rhein, Germany

In schizophrenia there is a disbalance of several neurotransmitter systems of the central nervous system, such as the dopamine and GABA (gamma aminobutyric acid) systems. On a neuroanatomical level the number of inhibitory interneurons, the complexity of dendritic arborizations and the number of synaptic spines of neurons are altered in distinct brain areas of schizophrenic patients as well as in animal models of schizophrenia. There are multiple rodent models to experimentally mimic both morphological features and behavioral alterations associated with the human disease. In the present study we pharmacologically activated the dopaminergic system with the selective D2 and D3 agonist quinpirole. We induced and evaluated both behavioral abnormalities and morphological changes after subchronic quinpirole application in male Sprague Dawley rats.

Subchronic as well as acute treatment with quinpirole lead to an increased locomotor activity in the open field test and produce clearly identifiable behavioral sensitization represented by hyperlocomotion (One-way ANOVA, *** $p < 0.0001$). The semiautomatic three-dimensional (3D) quantification of dendritic spines, enabled by the application of a Definiens Architect XD algorithm, yields no significant differences of total spine density [spines/ μm] after subchronic quinpirole-injection compared to acutely treated rodents in several brain regions: CA1 hippocampal region, striatum, prefrontal cortex and shell subregion of nucleus accumbens, respectively (t-tests, $p > 0.05$). Only in the core area of nucleus accumbens a significant increase of total spine density is detectable after subchronic quinpirole administration compared to acute treatment (t-test, * $p = 0.0464$). The semiautomatic classification of different spine classes (mushroom, thin, stubby, filopodia), also being predicated on a 3D-algorithm within Definiens Architect XD, reveals a significant rise of filopodia in the core region of nucleus accumbens (t-test, * $p = 0.0135$) as well as a strong trend for an elevated quantity of thin spines (t-test, $p = 0.0525$) in the prefrontal cortex for subchronically quinpirole-treated animals compared to their corresponding controls. These findings may represent a partial formation of new drug-environment associations emerging during the process of behavioral sensitization. Further neuroanatomical evaluations of the GABAergic system are currently ongoing.

ErbB4 modulates attention by controlling synaptic functions in the reticular nucleus of the thalamus

Sandra Ahrens, Santiago Jaramillo¹, Hiroki Taniguchi¹, Josh Z Huang¹, Bo Li¹

¹Cold Spring Harbor Laboratory, Neuroscience, 1 Bungtown Road, NY, 11724 Cold Spring Harbor, USA

The thalamic reticular nucleus (TRN) is critical in processing and filtering sensory stimuli. It has been thought to play an important role in attention, and the impairment in TRN function has been implicated in psychiatric disorders such as schizophrenia. TRN neurons, which are exclusively GABAergic, receive glutamatergic inputs from the cortex and thalamus, and send projections to the thalamus where they directly modulate the activity of thalamic relay neurons. Interestingly, TRN neurons are highly enriched in ErbB4, a gene that has been linked to both schizophrenia and bipolar disorder. Previous studies indicate that ErbB4 controls glutamatergic synapse maturation and plasticity. Based on these findings, we hypothesize that ErbB4 controls the development and function of glutamatergic synapses in TRN neurons, thereby controlling the normal function of the cortico-TRN-thalamic circuitry in attention. To manipulate ErbB4 function specifically in the TRN, we took advantage of the observation that Somatostatin (SOM) expression perfectly matches that of ErbB4 in the TRN, but not in other brain areas including cortex and hippocampus. By crossing the SOM-Cre line with the ErbB4^{lox/lox} animals, we have generated SOM/ErbB4^{-/-} mice in which ErbB4 gene is selectively ablated in SOM+ neurons in the TRN.

Using ChR2 to selectively stimulate the cortical or thalamic input onto TRN neurons, we found that the absence of only one copy of ErbB4 in SOM+ TRN neurons selectively enhances cortico-thalamic (CT) transmission but does not affect thalamo-cortical (TC) transmission. As a consequence the feed-forward inhibition of TRN neurons onto thalamic relay neurons driven by the CT-pathway is increased in SOM/ErbB4 deficient mice.

Remarkably, the SOM/ErbB4^{-/-} and ^{+/-} mice have altered performance in behavioral tasks, designed to test different aspects of attentional modulation of behavior. On the other hand, direct manipulation of TRN SOM+ neuronal activity using a pharmacogenetic system, the neuron-silencer hM4Di, also modulates attentional performance, suggesting that SOM+ neurons in the TRN constitute an essential element of the cortico-TRN-thalamic circuitry that controls attention.

Relationship between impulsivity, tobacco status and symptomatology in paranoid schizophrenia

Mounir Ouzir, Jean Michel Azorin², Nadia Correard², Sara-Nora Elissalde², Romain Padovani², Omar Battas¹, Driss Boussaoud³

¹Faculty of Medicine and Pharmacy, Laboratory of Clinical Neuroscience and Mental Health, 19 Rue Tarik Ibnou Ziad, BP: 9154 Mers Sultan , 20000 Casablanca , Morocco

²Department of Psychiatry, Sainte-Marguerite Hospital, Mediterranean University, 270 bd Sainte-Marguerite, 13009 Marseille, France.

³Institute of Systems Neuroscience, Mixed Research Unit 1106, INSERM & Aix-Marseille University, Faculty of Medicine and Pharmacy, 27, Boulevard Jean Moulin 13005 Marseille, France.

Abstract:

Background: Impulsivity displayed by patients with schizophrenia has recently become a matter of interest for psychiatrists and the focus of research over the last few decades. Various facets of impulsivity are examined, as well as the relationship between impulsivity and different behavioral problems. There is consistent evidence that impulsive behaviors are linked to symptomatology. In the current study, we propose a new integrative model of the relationship between impulsivity, psychopathological symptoms and tobacco status in patients with paranoid schizophrenia.

Methods: We investigated 33 paranoid schizophrenic patients and 37 age- and education-matched healthy controls using a battery of psychopathological scales included DSM-IV (SCID), the five-factor model of the PANSS (Gaag et al., 2006) to test whether symptom dimensions correlate with scores on the Barratt Impulsiveness Scale (BIS-10) and UPPS Impulsive Behavior scale. Spearman correlation and linear regression analyses were performed to investigate the relationship between PANSS five-factor, tobacco status and impulsivity measures.

Results: Severity of the five-factor model of the PANSS (except Disorganized Factor) and tobacco status correlated with several facets of impulsivity in patients with paranoid schizophrenia. However, when submitted to Stepwise regression analysis Positive Factor and tobacco status emerged as the significant explanatory variable of impulsivity.

Conclusions: The present study reflects the variable nature of impulsivity and argues that psychopathological impairments in schizophrenic patients (specially positive symptoms) and tobacco status might be mediator variables responsible for the effect of impulsivity.

Diras2: Candidate Gene for ADHD and its Expression in the Brain

Lena Weißflog, Nils Becker¹, Klaus-Peter Lesch¹, Andreas Reif¹

¹University of Würzburg, Department of Psychiatry, Psychosomatics and Psychotherapy, Fuechsleinstr. 15, 97080 Würzburg, Germany

Attention-deficit / hyperactivity disorder (ADHD) is a clinically heterogeneous childhood behavioral neurodevelopmental disorder which is highly persistent into adulthood and shows an heritability up to 80%. In previous studies, our group delineated the 9q22 region by both linkage studies and genome-wide association studies as a candidate locus for ADHD. This region harbors the DIRAS2 (MIM: 607863) gene which is coding for a Ras GTPase. The function of the gene product is still unknown but might include the regulation of cell morphogenesis.

In our previous work, we conducted a case-control association study in a total of >1600 ADHD cases and >1800 healthy controls and in two independent family-based childhood ADHD. Those studies revealed an association of DIRAS2 with the disorder.

To get more knowledge about the expression pattern of Diras2 in the brain, in situ hybridisations on mouse brain slices as well as immunohistological and immunocytochemical double stainings of mouse brain slices and hippocampal primary cells were done. Moreover the expression of Diras2 in the mouse brain during development was investigated by quantitative real time PCR (qPCR). To investigate DIRAS2 expression in the human brain, pooled human RNA samples were investigated by qPCR.

In situ hybridizations showed that Diras2 is expressed in the olfactory bulb, mainly in the mitral cell layer, the deep cellular zone of the anterior olfactory nucleus as well as the orbital cortex. In the posterior regions of the cerebral cortex a strong staining of distinct cortical layers could be observed. In addition, Diras2 is strongly expressed in the piriform cortex, the basolateral nucleus of the amygdala, the hippocampus, the locus coeruleus and the granular cell layer of the cerebellar cortex. These results match those gained by qPCR analyses of human RNA samples from the brain, which showed the highest DIRAS2 expression in the hippocampus followed by the cerebral cortex and the cerebellum. The results of the double staining of mouse brain slices and hippocampal primary cells revealed a presence of Diras2 in GABAergic and dopaminergic neurons but not in glia cells. The qPCR experiments in the developing mouse brains revealed a significant increase of Diras2 expression levels between the prenatal and the early postnatal group and between the early and late postnatal group.

These results indicate that DIRAS2 may play a role in the pathomechanism of ADHD.

The expression pattern of Diras2 in the mouse brain and the fact that it is expressed in neuronal cells but not in glial cells and that the expression levels increases during brain development provides further support to the assumption that this gene is involved in the pathophysiology of ADHD.

Re-sequencing of the gene, as well as functional studies like RNA interference induced knock down of Diras2 expression and further expression studies are currently done to explore the role of DIRAS2 in ADHD.

(A) social behavior and sexual preference in mice lacking Tryptophan Hydroxylase 2

Daniel Beis, Valentina Mosienko^{1,2}, Karolin Holzwarth³, Catherine Schweppe¹, Markus Wöhr^{4,5}, Natalia Alenina^{1,5}

¹Max-Delbrück-Center for Molecular Medicine, AG Bader, Robert-Rössle-Str. 10, 13125 Berlin, Germany

²Humboldt-University, Berlin, Germany

³Free University, Berlin, Germany

⁴Faculty of Psychology, Philipps-University Marburg, Germany

⁵equal contribution

Serotonin (5-Hydroxytryptamine, 5-HT) deficiency in the central nervous system (CNS) is thought to be associated with a diminution of motivation, mood and sexual interest, keeping this monoamine in the focus of neurobiological and psychiatric research. Moreover, accumulating evidence from animal studies correlate the central 5-HT system with sexual and aggressive behavior in rodents.

Mice emit distinct types of ultrasonic vocalizations (USVs). These USVs can occur after isolation in pups and during social and sexual interactions in juvenile and adult mice and serve important communicative functions. Interestingly, 5-HT_{1a} and 1b receptors have been identified as important factors, promoting USVs during social isolation in pups.

Tryptophan hydroxylase 1 and 2 (TPH1 & TPH2) are rate limiting enzymes for 5-HT synthesis in the periphery and the CNS, respectively. Consequently, TPH2-deficiency in mice (*Tph2*^{-/-}) features a CNS-specific 5-HT deficiency, while the peripheral serotonin levels are unaffected.

In this study we analyzed dyadic interaction in juvenile *Tph2*^{-/-} mice and their *Tph2*^{+/+} littermates as well as sexual preference and social response in adult male mice.

For the first experiment we isolated juvenile mice for one day before they were exposed to an unfamiliar mouse of the same age, sex and genotype. For the second approach we rated social interaction and vocalization to sexual stimuli (urine) in adult male animals before and after contact to female partners.

Analysis of social interaction in juvenile mice revealed loss of interest to establish social contacts in *Tph2*^{-/-} mice that was evident from the reduced amount of physical contacts. However, USV pattern did not differ between *Tph2*^{-/-} mice and controls. Interestingly, females of both genotypes emitted significantly more USVs than males.

Analysis of social interaction in adult animals revealed blunted sexual response in *Tph2*-deficient mice. Whereas adult control mice exhibited normal vocalization behavior during exposition to sexual stimuli, *Tph2*^{-/-} mice failed to show typical vocalization responses to sexual cues. Moreover, *Tph2*^{-/-} male mice showed significant increase in amount of aggressive attacks towards playmates during social interaction. In conclusion, deficiency in TPH2 leads to a visible loss of interest in social interaction during mouse lifetime. Moreover, despite being fertile, *Tph2*^{-/-} males fail to vocalize towards sexual cues, independently of their sexual experience. These results indicate that central serotonergic signaling is a critical modulator of social and sexual behavior in the mammalian brain.

Deficits in trace fear memory in a mouse model of the schizophrenia risk gene TCF4

Moritz J Rossner, Magdalena M Brzozka^{1,2}

¹ Max-Planck-Institute of experimental Medicine, Research Group Gene Expression, Hermann-Rein-Str. 3, 37075 Göttingen, Germany

² Ludwig-Maximilian-University Munich, Department of Psychiatry, Nussbaumstr. 7, 80336 München, Germany

The basic helix-loop-helix (bHLH) transcription factor TCF4 was confirmed in the combined analysis of several large genome-wide association studies (GWAS) as one of the rare highly replicated significant schizophrenia (SZ) susceptibility genes in large case-control cohorts. Focused genetic association studies showed that TCF4 influences verbal learning and memory, and modulates sensorimotor gating. Mice overexpressing Tcf4 in the forebrain (Tcf4tg) display cognitive deficits in hippocampus-dependent learning tasks and impairment of prepulse inhibition, a well-established endophenotype of SZ. The spectrum of cognitive deficits in SZ subjects, however, is broad and covers attention, working memory, and anticipation. Collectively, these higher order cognitive processes and the recall of remote memories are thought to depend mainly on prefrontal cortical networks. To further investigate cognitive disturbances in Tcf4tg mice, we employed the trace fear conditioning paradigm that requires attention and critically depends on the anterior cingulate cortex (ACC). We show that Tcf4tg mice display deficits in recent and remote trace fear memory and are impaired at anticipating aversive stimuli. We also assessed mRNA expression of the neuronal activity-regulated gene Fos in the ACC and hippocampus. Upon trace conditioning, Fos expression is reduced in Tcf4tg mice as compared to controls, which parallels cognitive impairments in this learning paradigm. Collectively, these data indicate that the reduced cognitive performance in Tcf4tg mice includes deficits at the level of attention and behavioral anticipation.

Association study of the polymorphisms of selective genes and major depressive disorder: a patient centered approach

Jan Lehotsky, Andrea Evinova¹, Igor Ondrejka², Dusan Dobrota¹

¹ Comenius University, Jessenius fac med, Med Biochem, Mala Hora 4, SK 03601 Martin, Slovakia

² Comenius University, Jessenius fac med, Psychiatry Clinic Univ hospital, Kollarova 2, SK 03601 Martin, Slovakia

Major depressive disorder (MDD) is a complex neuropsychiatric disorder where both gene-gene and gene-environment interactions play an important role, but the clues are still not fully understood. One carbon metabolism in the CNS plays a critical role in the synthesis and release of neurotransmitters which are relevant to depressive disorder. We studied genetic polymorphisms of the brain derived neurotrophic factor (BDNF) and the methylenetetrahydrofolate reductase (MTHFR) in association with major depressive disorder. We genotyped the BDNF G196A, the MTHFR C677T, and A1298C polymorphisms in 134 patients diagnosed with major depression and 143 control subjects in Slovak (Caucasian) cohort of patients and probands. We found no significant association of either the BDNF G196A or MTHFR C677T polymorphisms with major depressive disorder neither in female nor male group of patients. However, the MTHFR A1298C genotype distribution for the depressed patients was 36.6% (for AA genotype), 48.5% (AC) and 14.9% (CC) for the depressed patients, and 48.9% (AA), 42.7% (AC) and 8.4% (CC), respectively, for the control subjects. Patients with MDD had a higher prevalence of the CC genotype (OR = 2.38; 95% CI = 1.07–5.32; p = 0.032) and the AC + CC genotype (OR = 1.67; 95% CI = 1.03–2.69; p = 0.037) in comparison with the control subjects. This study shows that CC genotype of the MTHFR A1298C is associated with higher risk of MDD in Slovak population. Findings detecting particular combinations of polymorphisms of different genes may confer to the exploration of earlier onset and /or presence of the severe forms of MDD. Supported by MZ-2007/55-UK-16, and by project “Identification of novel markers in diagnostic panel of neurological diseases“code: 26220220114, co-financed from EU sources and European Regional Development Fund and VEGA 213/12.

The Evolution of the Extended Amygdaloid Complex in Teleost Fish – Lessons from the Zebrafish Transgenic Lines tg(*vglut2a*:GFP) and tg(*lhx2a*:GAP-YFP)

Thomas Mueller, Nicola Sebert¹

¹University of Freiburg, Institute of Biology I - Department of Developmental Biology, Hauptstrasse 1, 79104 Freiburg, Germany

The amygdaloid complex is the main center within the brain for the generation and maintenance of emotions. Studies link dysfunctions of the amygdala with a number of human affective disorders, such as schizophrenia, autism, and fear and anxiety disorders. In zebrafish—the emerging model system for the study of developmental genetics—the amygdaloid complex is poorly understood. To molecularly delineate the pallial amygdala (ventral pallium), the hippocampal division (medial pallium), and the isocortex-homolog (dorsal pallium), we analyzed the distribution of glutamatergic populations in the transgenic line tg(*vGlut2a*:GFP). In this line the promoter of the vesicular glutamate transporter 2a gene (*vGlut2a*) drives the expression of green fluorescent protein (GFP). We show that like the ortholog *VGLUT2* in mammals, *vglut2a*-GFP in zebrafish is expressed in derivatives of the ventral pallium that belong to the amygdaloid complex. The zebrafish dorsal pallium, in contrast, lacks *vglut2a*-GFP expressing neurons, again similar to the situation in mammals where the isocortex and the hippocampus are defined by the expression of *VGLUT1*. To determine the olfactory parts of the amygdala, such as the homologs of the piriform cortex and the nucleus of the lateral olfactory tract, we traced in the transgenic line tg(*lhx2a*:GAP-YFP) secondary olfactory projections from the olfactory bulb to the pallium. Again we demonstrate that the basic Bauplan of the zebrafish amygdaloid complex resembles the one of mammals. Thus our delineation of the extended amygdaloid complex in zebrafish provides a molecular-based map for future studies of the neural circuits that regulate emotions.

Truncated Disrupted in Schizophrenia 1 impairs cortical fast-spiking interneuron function and gamma oscillations

Jonas-Frederic Sauer, Michael Strüber^{1,2,3}, Marlene Bartos¹

¹Physiologisches Institut I, Albert-Ludwigs Universität Freiburg, Hermann-Herder Straße 7, 79104 Freiburg, Germany.

²Fakultät für Biologie, Albert-Ludwigs Universität Freiburg, Schänzlestraße 1, 79104 Freiburg, Germany.

³Spemann Graduate School for Biology and Medicine, Albert-Ludwigs Universität Freiburg, Albertstraße 19A, 79104 Freiburg, Germany.

Synchronous activity of cortical neuron assemblies at gamma frequencies is the basis of cognitive functions and substantially impaired in schizophrenia and depression. GABAergic inhibitory fast-spiking interneuron (FS-IN) signaling is important for the emergence of these fast brain rhythms, suggesting that FS-IN malfunction is linked to cortical deficits in mental diseases. However, how GABAergic network defects may contribute to psychiatric pathologies has not been addressed. Here we find that mice expressing truncated 'Disrupted in Schizophrenia 1' (Disc1), a major 'risk gene' mutation underlying psychiatric illness in humans, show reduced synchrony of gamma activity in the medial prefrontal cortex (mPFC). This impairment bases on alterations in FS-IN network function: Disc1 mPFC contains less parvalbumin-expressing FS-INs, which receive reduced excitatory synaptic inputs, form weaker inhibitory output synapses and show enhanced connectivity. Computational analysis indicates that these changes can explain gamma oscillation dysfunction. Our data thus provide a mechanistic framework to understand GABA-mediated pathologies in psychiatric disorders.

Electroconvulsive therapy in an animal model of depression

Wiebke Theilmann, Katarzyna Socala³, Claudia Brandt^{1,2}, Helge Frieling⁴, Stefan Bleich⁴, Wolfgang Löscher^{1,2}

¹University of Veterinary Medicine Hannover, Department of Pharmacology, Toxicology, and Pharmacy, Hannover, Germany

²Center for Systems Neuroscience, Hannover, Germany

³Department of Animal Physiology, Institute of Biology and Biochemistry, Maria Curie-Skłodowska University, Lublin, Poland

⁴Department of Psychiatry, Social Psychiatry and Psychotherapy, Hannover Medical School, Hannover, Germany

Major depressive disorders are one of the most common psychiatric illnesses in industrial nations. A very effective treatment of severe depression is the administration of controlled therapeutic seizures, which are known as electroconvulsive therapy (ECT). There are several experimental studies in which electroconvulsive shocks (ECS) are delivered to rodents via earclip electrodes, which is not in line with the clinical procedure where seizures are induced via stimulation of cortical areas, using electrodes attached to the scalp. It is known from epilepsy research that the location as well as the type of stimulation has a crucial impact on the seizure event.

Aim: In this study a model of ECS that is closer to clinical conditions should be established. Further inter- and intrastrain differences regarding the response to the ECS were investigated.

Methods: Male Wistar (Harlan, Janvier) and male Sprague-Dawley (Harlan) rats were implanted with screw electrodes over the primary motor cortex. The animals received five ECS on consecutive days. A simultaneous EEG-recording allowed the evaluation of seizure severity and length according to the clinical procedure. To compare the effect of our ECT paradigm with that of the traditional model of ECS, stimulation was also delivered via earclip electrodes. Moreover one group was treated with the tricyclic antidepressant imipramine. The antidepressant effect of the therapies was estimated in the forced swim test.

Results: In this study the antidepressant efficacy of the cortical electrical stimulation could be demonstrated. In comparison to the imipramine treatment, which increases the climbing behavior of the animals, the ECS leads to an enhancement of the general activity. Moreover there was a fundamental inter-strain difference of response in the rat forced swim test. So the choice of the strain is a very important parameter to consider and has a crucial impact on the validity of the model.

Outlook: This new established model for ECT is the basis for further studies in which it is planned to investigate mechanism of resistance to ECS.

Effect of deep brain stimulation in rats selectively bred for deficient prepulse inhibition, an endophenotype for Tourette's syndrome

Svilen Delchev Angelov, Joachim K. Krauss¹, Kerstin Schwabe¹

¹Medical University Hannover, Department of Neurosurgery, Carl-Neuberg-Str. 1, 30625 Hannover, Germany

Sensorimotor gating is disturbed in certain neuropsychiatric disorders with known or proposed abnormalities of basal ganglia (BG) function, such as schizophrenia and Tourette's syndrome (TS). Several case reports indicate that deep brain stimulation (DBS) in the nucleus accumbens (NAC) and centromedian-parafascicular complex (CM-Pf) improve symptoms in patients with TS. Rats with breeding-induced deficient prepulse inhibition (PPI), an operational measure for sensorimotor gating, may be used to study the pathophysiological mechanisms of TS and possible therapeutic strategies. Interestingly, these rats also show hyperlocomotion and reduced social interaction as compared to rats with high PPI.

To test the effect of DBS on PPI of startle, locomotion and social interaction rats with low and high PPI were bilaterally implanted with electrodes in the (CM-Pf, n=8 for PPI high and n=7 for PPI low) or the nucleus accumbens (NAC, n=6 for PPI high and n=9 for PPI low). After two weeks of postoperative recovery rats were stimulated (130 Hz, 80µs pulse width) for six days each with 0µA, 100µA and 150µA in random order.

While NAC DBS with intensities of 100µA and 150µA marginally improved PPI without reaching significance, CM-Pf DBS with 150µA significantly enhanced this measure in PPI low rats, without affecting PPI high rats. Stimulation of NAC and CM-Pf with either intensity did not reduce enhanced locomotor activity in PPI low rats, but CM-Pf DBS removed the different social interaction between PPI high and low rats.

This work indicates an important role of the CM-Pf in the modulation of sensorimotor gating. Rats with breeding-induced deficient PPI may be useful to further investigate the pathophysiological mechanisms of deficient sensorimotor gating and mechanisms of action of DBS in certain neuropsychiatric disorders.

An acute MK801-induced schizophrenia-like psychotic episode is followed by chronic and persistent deficits in hippocampal long-term potentiation and memory in freely moving rats

Valentina Wiescholleck, Denise Manahan-Vaughan^{1,2}

1 Ruhr University Bochum, Medical Faculty, Department of Neurophysiology, Universitätsstrasse 150, 44780 Bochum, Germany;

2 International Graduate School of Neuroscience, Universitätsstrasse 150, 44780 Bochum, Germany

First episode psychosis plays a crucial role in the development of chronic schizophrenia. As relapse rates are extremely high, more research is needed in order to understand the exact role of early psychosis in schizophrenia pathology and the mechanisms underlying its effects. Acute systemic injection of adult rats with the irreversible N-methyl-D-aspartate receptor antagonist, MK801, usually results in a transient schizophrenia-related behavioural profile in animals. In this study, we investigated the long-term consequences of a single schizophreniform event on an electrophysiological and a behavioral level in this animal model of acute psychosis.

Adult rats underwent implantation of stimulating and recording electrodes into the medial perforant path and the dentate gyrus granule cell layer, respectively. The study was commenced 10-14d after surgery. In control animals, patterned afferent stimulation at 200 Hz elicited robust LTP (>24h). One, two, three and four weeks after intraperitoneal treatment with MK801, long-term potentiation (LTP) in freely behaving rats was significantly impaired compared to control LTP. Object recognition memory was also significantly disturbed for several weeks.

We hypothesize that the persisting long-term deficit in the ability to express synaptic plasticity and to engage in object recognition memory reflects an increased vulnerability of the brain for further psychotic episodes. Furthermore, these data suggest that long-term deficits in synaptic plasticity may underlie cognitive impairments characteristic of schizophrenia.

Metabolite changes during treatment of ADHD children with atomoxetine and methylphenidate measured using proton magnetic resonance spectroscopy

Dušan Dobrota, Veronika Husarova¹, Michal Bittsanský¹, Igor Ondrejka¹, Hubert Polacek¹

¹Jessenius Faculty of Medicine in Martin, Comenius University, Malá hora 4, 036 01 Martin, Slovakia

Introduction:

Proton magnetic resonance spectroscopy (1H MRS) brought a new light into neurobiological representations of ADHD (attention deficit hyperactivity disorder) pathomechanisms in children and adults. Increased levels of NAA and Glx were observed in ADHD patients in comparison to healthy subjects in the areas of the prefrontal brain cortex and the semioval center. To our knowledge, there was only one promising preliminary 1H MRS study to compare the effects of methylphenidate and atomoxetine, during the therapy of ADHD. Therefore, we designed our study to find the differences in 1H MRS neurometabolite changes after two months of atomoxetine or methylphenidate treatment in children with the ADHD-combined type (ADHD-C).

Patients and Methods

Twenty-one children (mean age 12.3 years, range 6.1 to 16.8) with ADHD-C underwent 1H MRS examination before and after two months of treatment with methylphenidate (n=10) or atomoxetine (n=11). The spectra were taken from the dorsolateral prefrontal cortex (DLPFC, 8 ml) and white matter behind the DLPFC (anterior semioval center, 7.5 ml), bilaterally (Figure 1) using single-voxel 1H spectroscopy (1.5 T Siemens Symphony, PRESS, TE/TR = 30/3000 ms, 128 averages), and evaluated with the LCModel.

Results:

After two months of treatment with atomoxetine, we found decreased NAA/Cr in the left and increased Cho/Cr in the right DLPFC. After two months of treatment with methylphenidate, Glx/Cr increased in the left white matter. We did not find any other significant changes of these metabolites after the treatment.

Discussion:

Our results introduce new evidence about medication influences on brain neurometabolism in terms of working memory, attention, planning and task organization. Decreased NAA/Cr in the left grey matter could indicate decreased energy metabolism and brain activity in this area after atomoxetine treatment. Increased Cho/Cr in the right grey matter, after atomoxetine treatment, may represent increased membrane turnover. Increased Glx/Cr (multiplet consisting of the glutamate, glutamine and GABA resonances) in the left white matter, after methylphenidate treatment, could be the consequence of altered neurotransmission or neuronal-glia interaction.

Acknowledgement:

This work was supported by the grant of the Slovak Ministry of Health number 2007/57-UK-17 and by the project "CENTER OF EXCELLENCE FOR RESEARCH IN PERSONALIZED THERAPY (CEVYPET)", code: 26220120053, co-financed from EU sources and European Regional Development Fund.

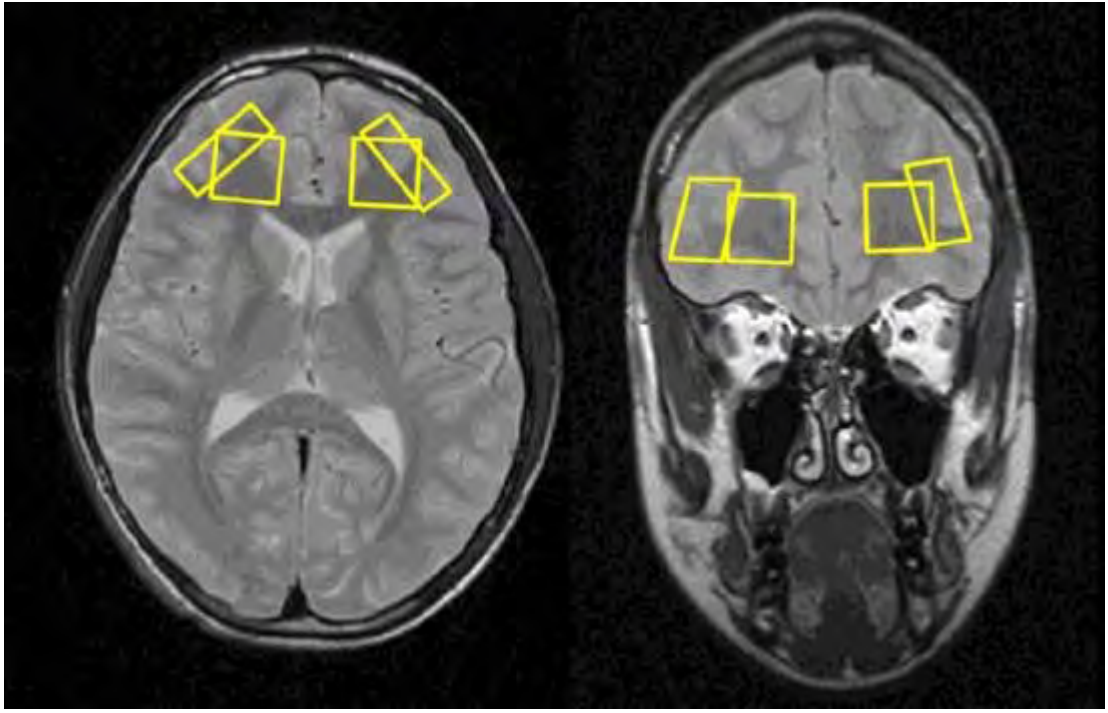

The Role of NRG1 in cortical development and network integrity

Tilman Unterbarnscheidt, Maria Clara Soto-Bernardini¹, Viktorija Velanac¹, Sophie Crux¹, Klaus-Armin Nave¹, Markus H. Schwab¹

¹Max-Planck-Institute of Experimental Medicine, Neurogenetics, Hermann-Rein-Str. 3, 37075 Göttingen, Germany

The Neuregulin 1 (NRG1) gene encodes a family of growth and differentiation factors with an epidermal growth factor (EGF)-like signaling domain that serve as ligands for receptor tyrosine kinases of the ErbB family. NRG1 has been implicated in a variety of neural developmental processes and synaptic plasticity in the mature brain. ErbB4, the most prominent neuronal NRG1 receptor in the brain, is enriched in GABAergic interneurons. These interneurons form inhibitory networks and modulate the activity of excitatory projection neurons. NRG1 and ErbB4 are susceptibility genes for schizophrenia, and inhibitory network dysfunction has been suggested to contribute to various neuropsychiatric disorders, including schizophrenia. Increased expression of NRG1 type III was found in postmortem brains of schizophrenia patients, suggesting that NRG1-ErbB4 hyperstimulation may induce cortical network dysfunctions.

To study NRG1-ErbB4 hyperstimulation in a controlled *in vivo* model, we have generated a transgenic mouse line that allows Cre recombinase-mediated expression of NRG1 type III in distinct brain regions. In addition, by breeding to CreER driver lines and tamoxifen treatment, NRG1 overexpression can also be temporally controlled. We will use such approaches to examine the impact of chronic pre- and postnatal as well as acute NRG1 type III overexpression on brain functions *in vivo*. We believe that these studies will provide a framework for the correlation of brain deficits in mouse models of NRG1-ErbB4 hyperstimulation and schizophrenia endophenotypes, and a starting point for the development of future treatment strategies.

Behavioral consequences of early life stress and early life enrichment in CD1 mice

Antonia Post, Sandy Popp¹, Ulrich Dischinger¹, Aet Alttoa¹, Andreas Reif¹

¹University Clinic Würzburg, Department of Psychiatry, Fuchsleinstr. 15, 97080 Würzburg, Germany

Some experimental studies in animals have been able to identify early life stress as a possible risk factor for behavioral abnormalities in later life. Other studies have found positive behavioral effects in mice that live under environmental enrichment conditions. However, these results are not always conclusive, as contradictory and sometimes paradoxical results have been found in both lines of study. We therefore looked at the behavioral effects of both early life stress in the form of maternal separation (MS) and early life enrichment (EE) in CD1 mice, a strain usually sensitive to environmental changes, and compared them to controls in one single study. MS was carried out from PND 1 to 21 and lasted for 3 hours every day. EE consisted of changing toys every week, started on PND 1 and was continued throughout the lives of these mice to eliminate the possibility of negative effects of deprivation.

Neither elevated plus maze nor the light dark test revealed differences in anxiety-like behavior between the three groups. Long-term open field testing showed a distinct hypoactivity in female EE mice as compared to female controls and MS animals, whereas male mice did not differ between groups. There were no differences between groups in the training phase of the Barnes Maze. However, when it came to reversal learning, EE animals showed greater flexibility than the other groups. Regarding depression-like behavior, we found paradoxical results. MS and control animals were not different for sucrose preference, but the EE animals showed a decreased interest in the sugary solution. In the forced swim test, MS animals spent significantly more time struggling compared to both control and EE mice.

Concluding, effects of early life interventions seem to be not only dependent on strain and exact conditions, but also on sex. Some of the apparently negative effects might be also be construed as being adaptive and some influences of negative environment might also be beneficial in certain situations. More and broader behavioral testing might illuminate more detailed aspects of changed behavior following environmental manipulations, and neurobiological testing is needed to examine the underlying biological mechanisms.

Analysis of the influence of odor stimulation with izoamilacetate on the psychophysiological state of human

Iuliia Sosiedka, Sergii Tukaiev², Sergii Krizhanovskiy², Igor Zima², Olga Radchuk³

¹National Taras Shevchenko University of Kyiv , Educational and Scientific Centre "Institute of Biology", Department of Human and Animal Physiology, 64/13, Volodymyrs'ka St., , 01601 Kyiv, Ukraine

²National Taras Shevchenko University of Kyiv, Educational and Scientific Centre "Institute of Biology", Department of Physiology of Brain and Psychophysiology, Kyiv, Ukraine

³Institute of Communication and Health, Università della Svizzera italiana, Lugano, Switzerland

Investigation of the influence of olfactory stimuli on human is relevant because of the close relationships between olfactory and emotogenic brain structures. Olfactive stimuli including essential oils are widely used to correct human psychophysiological state, but in most cases the mechanisms and effects of their activity are not physiologically justified. The impact of a purely olfactory stimulus on the psychophysiological state of an individual is an issue of particular interest. The aim of this study was to investigate immediate and delayed reactions under odor stimulation with izoamilacetate. 27 healthy volunteers (women and men) - students aged 18 to 23 years with no documented manifestations of rhinal pathologies participated in this study. Written informed consent was obtained from each participant in accordance with the Helsinki Declaration, and the study was approved by the local ethical committee. To assess the impact of what on the mental state of volunteers, data were collected before and after the experiment. We used the following tests: WAM (Well-being, Activity, Mood), State Anxiety Inventory by C. Spielberger, Y. Hanin and the test "Acute mental fatigue" by Leonova. EEG was registered over a period of 20 minutes during the rest state. The first 3 minutes were considered as background, during the next 10 minutes we effected odor stimulation. During olfactory stimulation and EEG recording, the subjects were in a soundproof darkened chamber, in a comfortable armchair in reclined position, with their eyes closed. Participants were informed that while recording resting baselines they should minimize blinking and moving, but not to be too much concerned about that to be distracted. The spectral power (SP) of all frequencies from 0.2 to 35 Hz was estimated. The Wilcoxon test was carried out to compare dependent samples, the Speerman rank test was carried out for the correlation analysis. During the first minute of olfactory stimulation we observed generalized decrease in SP (excluding anterior frontal zones) in θ , α_1 , α_2 and β_1 -subbands. During the next minute there was increase in θ_1 (locally), θ_2 (right hemisphere) and α_1 -subbands (posterior zones), which indicates emotional attitude towards olfactory stimulus. EEG shifts under the smell perception did not demonstrate prolonged changes of neurodynamics of human brain: after 10 minutes of odor stimulation using izoamilacetate we detected the local increase of the SP in the frontal zone. At the same time the results of psychological tests demonstrated that izoamilacetate had long-term effect on the psychological condition of the volunteers by decreasing of State Anxiety and acute mental fatigue; it also worsened well-being and reduced activity. It should be noted that we found inverse correlation initial State Anxiety with SP in α_1 -subband in frontal zone and direct correlation in β_2 -subband in parietal and frontal zones under odor stimulation. Thus, our results suggest that olfactory stimulus exert a significant complex influence on the psychophysiological condition of the volunteers.

Vision loss after peripheral optic nerve lesion is related to permanent alteration of long-range cortical functional connectivity: an EEG resting state study

Michal Bola, Carolin Gall¹, Christian Moewes², Anton Fedorov¹, Hermann Hinrichs³,
Bernhard A. Sabel¹

¹Otto-von-Guericke University of Magdeburg, Medical Faculty, Institute of Medical Psychology, Magdeburg, Germany.

²Otto-von-Guericke University of Magdeburg, Department of Computer Science, Magdeburg, Germany.

³Otto-von-Guericke University of Magdeburg, University Clinic, Department of Neurology, Magdeburg, Germany.

- Introduction: Our understanding of how the visual system of the brain works has evolved from a rather static feature detection specialization of certain brain areas to a complex and dynamic network of interacting elements. Consequently, our understanding of the neurological dysfunction changes: not only local tissue loss is responsible for functional loss but also downstream alterations of connectivity networks that reach far beyond the lesion locus. Yet, this issue has not been studied in the field of visual impairments following CNS lesions.

The goal of the present study was to address the role of cortical functional connectivity changes in patients with visual field loss due to optic nerve lesions. The rationale for studying peripheral lesions was to assess functional connectivity changes under functional deprivation conditions, without central brain damage as a possible confounder.

- Methods: Resting state EEG signal (30 channels, acc. to the 10-20 system) was recorded from 15 patients with pre-chiasmatic visual system damage and 13 age-matched normal controls at eyes closed condition. Following standard preprocessing, the signal was divided into 1s-epochs and epochs containing artifacts were discarded. Further, power density, coherence, and Granger Causality (Seth, 2010) were calculated. Coherence results were analyzed either (i) as absolute values indicating coupling within and between chosen regions of interest, and (ii) as individually thresholded binary graphs, serving to calculate small-world parameters (Rubinov and Sporns, 2010).
- Results: Between group differences were found only in the high alpha band (11-13Hz) but not in any other frequency band analyzed (delta, theta, low alpha, or beta) as follows:
 1. Firstly, occipital regions (O1, O2) high alpha band exhibited lower power in patients compared to controls in (rmANOVA, interaction: $p=0.005$).
 2. Secondly, in patients short-range functional connectivity (coherence) was weaker within both, occipital (O1, O2) and frontal (Fz, FC1, FC2) regions of interest (rmANOVA, group: $p=0.015$).
 3. Thirdly, decreased long-range coherence was noted in patients between occipital and frontal regions (t-test, $p=0.033$). These results were confirmed with Granger causality analysis which

revealed that the strength of both, bottom-up (occ. to frontal) and top-down coupling (frontal to occ.) was impaired in patients (rmANOVA, group: $p=0.032$).

4. Finally, coherence network topology (Fig. 1) revealed that the clustering coefficient (Rubinov and Sporns, 2010) was lower in patients' high-alpha coherence networks than in control subjects (t-test: $p=0.025$).

- **Conclusions:** Connectivity changes in the resting state EEG of partially blind patients with peripheral visual system damage are indications of permanent alterations in cortical network activities. All changes were specific to the high-alpha band suggesting a special role of this narrow frequency band in proper visual functioning. We interpret the decreased power, loss of connectivity strength, and reduction of the clustering coefficient as a loss of synchronization among widely distributed brain regions. There were no signs of compensatory plasticity, e.g. increased connectivity strength in any regions.

- **Figure 1.** Analysis of the coherence networks topology with the small world parameters. All graphs contain the same number of edges. The coherence difference graphs display edges present in controls but missing in patients (blue) and edges missing in controls but present in patients (red). Black dots represent standard EEG electrodes, with FP1 and FP2 up, O1 and O2 bottom. The right shows clustering coefficient and characteristic path length.

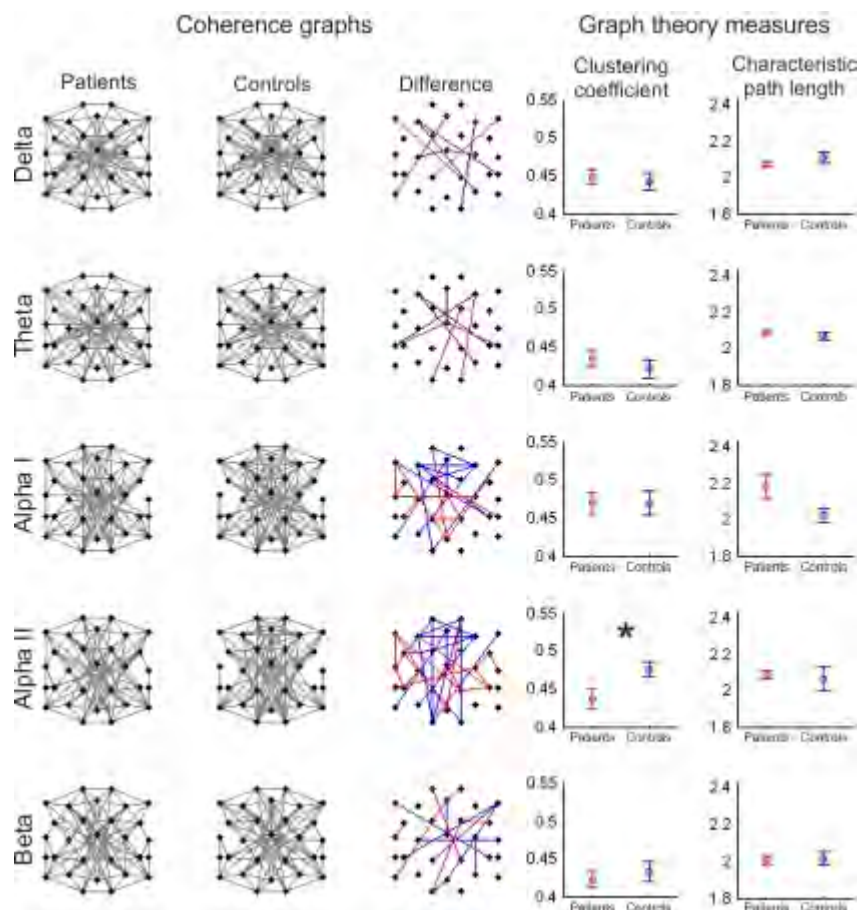

Regional and cellular expression pattern of Cadherin-13 in the murine brain

Sarah Andrea Sich, A. G. Schmitt¹, K.-P. Lesch¹, O. Rivero¹

¹Molecular Psychiatry, Laboratory of Translational Neuroscience, Department of Psychiatry, Psychosomatics and Psychotherapy,
University of Würzburg, Würzburg, Germany

Introduction: Cadherin-13 (Cdh13) is an atypical member of the cadherin superfamily. It lacks the cytoplasmic domain by which classical cadherins are thought to exhibit their functionality as cell adhesion molecules. This variation implies a different functionality of Cadherin-13. Indeed, it has been argued that Cadherin-13 may be a signaling rather than an adhesion molecule. Interestingly, several genome-wide studies for attention-deficit/hyperactivity disorder (ADHD) and some of its comorbid disorders have converged on its gene locus CDH13. In vitro studies hint towards a role of Cadherin-13 as a negative regulator of neurite outgrowth and axon extension. However, only few studies have investigated the exact properties of Cadherin-13 in the brain and its contribution to neurodevelopmental disorders. The objective of this study is the detailed characterization of the regional and cellular distribution pattern of Cadherin13 in the murine central nervous system to provide a basis for further investigating its functionality.

Methods: Accordingly, Cdh13 mRNA was detected on wildtype murine brain tissue by in situ hybridization (ISH). Subsequently, we investigated the presence of Cdh13 mRNA in various neurotransmitter systems. For this purpose, immunohistochemistry was performed directly after ISH, using antibodies against specific markers, e.g. Tryptophan hydroxylase2, Glutamic acid decarboxylase 65/67 and Tyrosine hydroxylase, respectively. Immunohistochemistry using a polyclonal anti-Cadherin-13 antibody was also performed to compare the distribution of Cdh13 mRNA and Cadherin-13 protein in wt murine brain.

Results: Our ISH experiments clearly show that Cadherin-13 is expressed in various brain regions, e.g. the prefrontal cortex and structures of the limbic system like the amygdala and the hippocampus. Interestingly, the presence of Cdh13 mRNA in serotonergic raphe neurons was confirmed. Situated in the brain stem, these neurons extend projections to large areas of the forebrain. In some of these projecting regions, expression of Cadherin-13 was found. The immunohistochemistry supported the ubiquitous distribution of Cadherin-13 throughout the murine brain, with expression in the intracellular space, rather than the cell bodies. A laminar staining is found in the hippocampus, with a distinct cellular expression of both Cdh13 mRNA and Cadherin-13 protein in the stratum oriens. In the cerebral cortex, Cdh13 mRNA and Cadherin-13 protein expression are present in specific layers.

Conclusions: Cdh13 mRNA is expressed in many areas of the brain which are interconnected. It is expressed in nuclei of the brain where GABA-ergic, dopaminergic or serotonergic neurons are concentrated. Particularly, it can be found in serotonergic raphe neurons and Cadherin-13 protein expression in projecting regions of these, therefore suggesting the role of Cdh13 in the development and function of the serotonergic system.

Lifelong *Tph2* deficiency results in hyperactivity and altered emotional behavior

Jonas Waider, Sandy Popp¹, Florian Proft¹, Lise Gutknecht^{1,3}, Esther Asan², Klaus-Peter Lesch¹

¹University of Wuerzburg, Department of Psychiatry, Psychosomatics and Psychotherapy, Fuechsleinstrasse 15, 97080 Wuerzburg, Germany

²University of Würzburg, Institute of Anatomy and Cell Biology, Koellikerstr. 6, 97070 Würzburg

³Institute of Functional Genomics, CNRS UMR 5203, INSERM U661, University of Montpellier I and II, 141 rue de la Cardonille, 34094 Montpellier, France

Alterations in the serotonergic system have been associated with various disorders of emotion regulation as well as various processes of metabolic homeostasis. Tryptophan hydroxylase 2 (Tph2) is the key enzyme in neural serotonin (5-HT) synthesis and has been associated with a wide range of behavioral traits as well as neurodevelopmental and psychiatric conditions, such as depression, bipolar disorder, anxiety disorders and attention-deficit/hyperactivity disorder (ADHD). Various 5-HT deficient mouse models display alterations in emotion-like behavior.

Tph2 knockout (-/-) mice were generated displaying extremely reduced 5-HT levels in the brain. However, formation of serotonergic neurons and pathfinding of their projections seem not to be impaired. This study demonstrates that lifelong 5-HT depletion results in an altered metabolism and altered emotional-like behavior in *Tph2*^{-/-} mice. Furthermore this behavioral phenotype is associated with adaptational changes of the GABAergic and Glutamatergic system within limbic brain regions indicated by high-performance liquid chromatography (HPLC) and stereological counting of GABAergic cells numbers in limbic brain regions to compensate lack of 5-HT function.

Metabolic imaging after noise trauma in tinnitus versus non-tinnitus conditions

Florian Theden, Sara Euteneuer², Dietmar Kuhl¹, Claudia Mahlke^{1,4}

¹ Center for Molecular Neurobiology Hamburg, Institute for Molecular and Cellular Cognition, University Medical Center Eppendorf, Falkenried 94, 20251 Hamburg

² Hals-Nasen-Ohrenklinik, Universitätsklinikum Heidelberg, Im Neuenheimer Feld 400, 69120 Heidelberg

³ current address: Audiocure Pharma GmbH, Schlegelstrasse 9, 10115 Berlin, Germany

⁴ current address: Cluster of Excellence NeuroCure, Charité – Universitätsmedizin Berlin, Charitéplatz 1, 10117 Berlin

Subjective tinnitus is defined as a persistent perception of a sound in the absence of an acoustic stimulus. Imaging studies in tinnitus patients reveal altered neuronal activity in auditory and non-auditory brain regions related to the phantom sound perception. In animal models, tinnitus can be induced by noise trauma, which leads to the perception of sounds in a subgroup of animals. So far very few studies have compared neuronal activity patterns between tinnitus-perceiving and non-perceiving animals. Here we used 2-deoxy-D-[14C]-glucose (2-DG) to screen metabolic activity in the entire mouse brain with and without behavioural evidence for tinnitus two weeks after unilateral noise trauma. To analyse 2-DG uptake, we performed statistical parametric mapping (SPM) in three-dimensional reconstructions of the brains. Auditory brain stem responses (ABR) after unilateral noise trauma revealed a permanent threshold shift on the exposed ear and a reduction of 2-DG uptake along the afferent auditory pathway. Tinnitus perception was evaluated using a modified version of the acoustic startle paradigm with a short gap presented in constant background noise to inhibit the startle amplitude. In animals with behavioural indications of phantom sound perception, 2-DG uptake was reduced in the contralateral auditory cortex (AC), in contralateral mediodorsal parts of the striatum, the ipsilateral amygdala and the bulbus olfactorius. In contrast, activity was increased in the ipsilateral AC, the ipsilateral nucleus accumbens and the striatum, the contralateral hippocampus, the superior colliculus, the cingulate gyrus and the thalamic reticular nucleus (TRN). When comparing animals with behavioural indications for tinnitus after noise trauma to noise exposed animals without signs of tinnitus perception we observed a decrease in the ipsilateral striatum and ipsilateral cingulate gyrus and an increase in activity in the ipsilateral superior colliculus, the ipsilateral globus pallidus, the contralateral TRN and most interestingly, the contralateral cochlear nucleus (CN). Chronically elevated neural activity in the dorsal CN (DCN) has been observed after high-level sound exposure leading to the suggestion that this nucleus is the primary source of chronic tinnitus activity. However, more recent studies investigating tinnitus generation after DCN ablation indicate that the DCN is a trigger for alterations elsewhere in the central nervous system. The data presented here supports this view of a more complex mechanism of tinnitus generation involving alterations in auditory as well as non-auditory subnetworks.

Stress suppresses monoaminergic neuromodulation of hippocampal inhibition

David Gruber, Kate Elizabeth Gilling^{1,2}, Anne Albrecht^{3,4}, Oliver Stork³, Uwe Heinemann¹, Joachim Behr^{1,2}

¹Institute of Neurophysiology,

²Department of Psychiatry and Psychotherapy, Charité - Universitätsmedizin Berlin, 10117 Berlin, Germany

³Department of Genetics and Molecular Neurobiology, Institute of Biology and Center for Behavioural Brain Sciences, Otto-von-Guericke University Magdeburg, 39120 Magdeburg, Germany

⁴Department of Psychology, University of Haifa, 31905 Haifa, Israel

Substantial evidence indicates that after stressful life events a high anxiety trait may develop into an anxiety disorder (PTSD, panic disorder) or depression. By activation of the median and dorsal raphe nuclei, which send a major serotonergic input to the hippocampus, stressful events enhance serotonin levels in the dentate gyrus. By using whole cell recordings in an anxiety disorder/PTSD model (Tsoory and Richter-Levin 2006) we assessed the effects of juvenile, adult as well as combined stress upon 5-HT-mediated modulation of cellular properties and synaptic inhibition of ventral dentate gyrus granule cells. Serotonin hyperpolarized cells, decreased their input resistance and reduced inhibition of IPSCs through activation of a K⁺ conductance. These effects were mediated by the 5-HT_{1A} receptor and were significantly reduced in stressed animals compared to controls. Furthermore, spontaneous GABAergic transmission was reduced, an effect involving the 5-HT₃ receptor. RNA expression analysis confirmed these findings. We conclude that stress modulates the effects of 5-HT in the dentate gyrus in an age- and stressor-dependent manner.

Topographic variability of language sites across time

Dieter M. Weinert, Eduard Kraus²

²¹Helios Vogtland Clinic, Neurosurgery, Röntgenstraße 2, 08529 Plauen, Germany

Convincing evidence of individual variability in location of language exists from intraoperative cortical stimulation results during awake craniotomies in patients with lesions in eloquent areas. However, little information is available whether the localization of these areas is stable over time or plastic changes allow a shift of the functional units in the adult brain.

The purpose of this investigation was to find out whether the localization of language associated areas in the inferior frontal gyrus was reproducible in a 23-year-old, right-handed man who presented with a history of febrile seizures and was diagnosed with MRI scans suggesting a left temporal low grade astrocytoma. Neurological examination was normal. Surgery and the reoperation for recurrence of the tumor 4 years later was performed in local anesthesia with a bone flap of 2.5 cm in diameter to expose the superior temporal gyrus and the perisylvian cortex of the frontal lobe. Brain mapping techniques involved cortical stimulation, electrocorticography for detecting afterdischarges during stimulation and simultaneous monitoring for language functions. Using a constant-current stimulus isolation unit connected to a bipolar electrode with the tips 2 mm apart stimulation was performed systematically at current intensities of 5 to 20 mA (50Hz, 0.2 ms). In the first operation reversible speech arrest or slowing of speech during stimulation could be provoked in only two circumscribed small areas in the inferior frontal gyrus, an area which was not infiltrated by the tumor. These effects were reproducible after tumor removal. At reoperation 4 years later the former area of the stimulation effect could be easily identified because the same surgical approach was used. In contrast to the first operation no language site was detectable. This area was still free of tumor. The patient showed no aphasia at any time.

These results suggest a reorganization of the network involved in the processing of language.

Cocaine-induced circuitry reorganization

Anna Suska, Brian R. Lee², Yan Dong³, Oliver Schlüter¹

¹European Neuroscience Institute, Molecular Neurobiology, Grisebachstr. 5, 37077 Göttingen, Germany

²The Scripps Research Institute, 130 Scripps Way, Jupiter, FL, USA

³University of Pittsburgh, Department of Neuroscience, A210 Langley Hall/ 5th & Ruskin Ave, Pittsburgh, PA, USA

Drug addiction has been conceptualized as an extreme, pathological form of memory. One potential mechanism underlying addiction-related memories is drug-induced plastic changes at glutamatergic synapses within the brain reward pathway, comprising the ventral tegmental area (VTA), prefrontal cortex (PFC), hippocampus, amygdala, nucleus accumbens (NAc), and related regions. Glutamatergic neurons from the PFC, hippocampus and amygdala project onto GABAergic neurons in the NAc, presumably transmitting differential aspects of addiction-associated information. Despite extensive results depicting postsynaptic alterations following cocaine exposure, it remains largely elusive whether presynaptic sites of these glutamatergic synaptic transmissions are also affected. Using a combination of optogenetic tools to dissect specific afferents and multiple-probability fluctuation analysis to examine presynaptic properties, our ongoing studies demonstrated that repeated exposure to cocaine via either i.p. injections or self-administration increased the release probability of PFC-to-NAc synapses but not amygdala-to-NAc synapses. Those presynaptic adaptations appear to be long-lasting and ever-growing as the effects become more robust along the course of withdrawal (45 d). These findings, together with previous results showing postsynaptic enhancement, suggest that glutamatergic transmissions to the NAc are profoundly enhanced during long-term withdrawal from exposure to cocaine.

The lateral habenula: Small nuclei with large effect on depression?

Anne Stephanie Vogel, Miriam A. Vogt¹, Natascha Pfeiffer¹, Mazahir T. Hasan², Rolf Sprengel², Peter Gass¹

¹Central Institute of Mental Health Mannheim, RG Animal models in psychiatry, J 5, 68159 Mannheim, Germany

²Max Planck Institute for medical research, Department of Molecular Neurobiology, Jahnstraße 29, 69120 Heidelberg, Germany

Although depression is a severe life-threatening disease which strongly impairs the quality of life of affected patients, the available therapeutic methods are not sufficient to evoke amelioration in all patients. The neurobiological basis of depression still constitutes a conundrum and further basic research is considered to help developing new therapeutic approaches.

An emerging field of research is the influence of the lateral habenula (LHb), a relatively small nucleus in the brain, on depression. It plays a role in motor activity, sleep, responses to aversive and rewarding stimuli amongst others. Several studies, including lesion studies in rats, suggest that the LHb might play a role in depression.

The approach used in this study to evaluate the impact on depressive-like behavior in mice was to generate mice with bilateral functional ablations of the LHb and subsequent analysis of behavior. Therefore a protocol was developed and successfully established for a targeted infection of the LHb via stereotactic injections with recombinant adeno-associated virus, which led to the expression of a toxic protein which eliminates synaptic transmission. By this means the LHb was disconnected from the circuitry.

Animals with LHb functional ablation showed reduced motor activity compared to sham-operated mice or mice with injections of an inactive control virus. This finding is contradictory to findings in rats, where animals with LHb lesions showed an increase of locomotion. Apart from this finding, mice with functional ablation of the LHb did not display altered behavior compared to control and sham-operated mice, neither circadian rhythmicity, anxiety nor in depressive-like behavior although the LHb is known to be involved in all this processes. Rats with lesions of the LHb are known to demonstrate less depressive-like behavior, but mice with functionally comparable but far less invasive ablations of the LHb did not show a tendency towards less depressive-like behavior.

With the protocol established in this project it is possible to further investigate the function of the LHb since the application of rAAVs is not limited to functional ablation but also allows further genetic manipulations.

Poster Topic

T14: Vision: Invertebrates

- T14-1A** Do crickets integrate polarotaxis and phonotaxis?
Hannah Julia Martina Haberkern, Berthold Hedwig
- T14-2A** Serial Block Face Scanning Electron Microscopy (SBEM) to Reconstruct a Locust Motion Detecting Pathway
Stefan Wernitznig, Armin Zankel, Peter Pölt, F. Claire Rind, Gerd Leitinger
- T14-3A** Desert ant's navigation: effects of conflicting celestial compass information
Fleur Leibold, Bernhard Ronacher
- T14-1B** Asymmetric polarotactic response of locusts in a tethered flight situation
Johannes Schuh, Uwe Homberg, Sarah Grant, Ronny Rosner
- T14-2B** Topographic organization of the posterior optic tubercle in the locust brain: possible role in the generation of an internal sky compass
Jerome M. Beetz, Basil el Jundi, Stanley Heinze, Uwe Homberg
- T14-3B** Peripheral neural circuits underlying colour discrimination in *Drosophila*
Christopher Schnaitmann, Christian Garbers, Thomas Wachtler, Hiromu Tanimoto
- T14-1C** Visual responsiveness of central-complex neurons in the desert locust *Schistocerca gregaria*
Tobias Bockhorst, Ronny Rosner, Uwe Homberg
- T14-2C** Impact of octopaminergic modulation on the processing of natural dynamic optic flow in the fly visual system
Diana Rien, Roland Kern, Rafael Kurtz
- T14-3C** Color coding in interneurons of the honeybee
Benjamin H Paffhausen, Randolph Menzel
- T14-1D** Light-induced plasticity of giant synapses in the lateral accessory lobe of the desert ant, *Cataglyphis fortis*
Franziska Veronika Schmitt, Sara Mae Stieb, Rüdiger Wehner, Wolfgang Rössler
- T14-2D** Distribution patterns of SIFamide in hemimetabolous insects
Andreas Arendt, Julia Schulze, Susanne Neupert, Reinhard Predel, Monika Stengl
- T14-3D** Neuronal organization of light-entrainment in the Madeira cockroach (*Rhyparobia maderae*)
Julia Schulze, Thomas Schendzielorz, Susanne Neupert, Reinhard Predel, Monika Stengl

Do crickets integrate polarotaxis and phonotaxis?

Hannah Julia Martina Haberkern, Berthold Hedwig¹

¹University of Cambridge, Department of Zoology, Downing Street, CB2 3EJ Cambridge, United Kingdom

The goal of this study was to investigate the influence of polarized light and acoustic stimuli on course control, in particular on orientation and turning behaviour of tethered walking crickets (*Gryllus bimaculatus*).

When presented with an auditory stimulus resembling a male's calling song female crickets show phonotaxis, i.e. they turn and walk towards the sound source. As many insects crickets perceive the e-vector orientation of polarized light. There is also evidence for polarotactic behaviour in the sense that walking crickets maintain a specific orientation angle with respect to the e-vector of the polarized light.

While responses to either auditory stimuli or polarized light have been studied extensively, both on the level of behaviour as well as on the level of neuronal processing, little is known about if and how sensory information from these two modalities is integrated.

I aim to investigate the mechanisms of bimodal integration of auditory and polarized light stimuli. Female crickets are simultaneously presented with linearly polarized light with a defined e-vector orientation from above and with a sound pattern resembling a male calling song coming from the side. Both stimuli are presented under open loop conditions to a tethered animal walking on a trackball. From the cricket-induced rotation of the trackball a (virtual) walking trajectory is reconstructed which is then used as a behavioural read out.

The sensory processing pathways for polarized light and auditory stimuli in the cricket are well characterized, which helps to guide the investigation of physiological mechanisms underlying the integration process.

Serial Block Face Scanning Electron Microscopy (SBEM) to Reconstruct a Locust Motion Detecting Pathway

Stefan Wernitznig, Armin Zankel², Peter Pölt², F. Claire Rind³, Gerd Leitinger¹

¹Medical University of Graz, Institute of Cell Biology, Histology and Embryology, Harrachgasse 21, 8010 Graz, Austria

²Graz University of Technology, Institute for Electron Microscopy and Fine Structure Research, Steyrergasse 17, 8010 Graz, Austria

³Newcastle University, Institute of Neuroscience and School of Biology, Ridley Building, Claremont Road, Newcastle upon Tyne NE1 7RU, UK

In the optic lobe of locusts a neuronal circuit is present which warns the animal of imminent collision. The key players of this circuit are two neurons: the Lobula Giant Motion Detector 1 and 2 (LGMD 1 & 2). An object on collision course causes a high firing rate of the LGMD and this faithfully elicits collision avoidance behaviour.

The LGMD receives synaptic input from hundreds of afferent neurons, whose arrangement could play a crucial role in the collision detection system. They are clustered in great dendritic fields of the LGMD, where dozens of afferents are closely together in rows (Fig. 1). The characteristic of these afferent neurons is that an active one might inhibit its neighbouring cell and at the same time have an excitatory connection with the LGMD. Consequently objects that fly past the animal will not activate enough afferent neurons to pass the threshold of the LGMD. Only objects approaching on collision course would stimulate such a large number of afferent neurons that this lateral inhibitory effect does not have an impact [1].

So the knowledge of the precise location of the input and output synapses of the afferent neuron is important to verify this hypothesis.

We are reconstructing the neuronal circuitry using Serial Block Face Scanning Electron Microscopy (SBEM, see ref. [2]), in which ultramicrotomy and scanning electron microscopy are combined. Serial sections of a tissue block are made within the microscope chamber using a 3ViewTM ultramicrotome (Gatan, Inc, Pleasanton, CA, U.S.A.), and the block face is repeatedly scanned using an ESEM Quanta 600 FEG from FEI, thus producing series of micrographs (see reference [3]). This is a fast way of producing hundreds of serial micrographs. These form the basis for reconstructing the branching pattern and the locations of the input and output synapses of the afferent neurons (Fig. 1). By reconstructing whole neurons, we aim to be able to visualise their connectivity and their origin. Elucidating the collision avoidance pathway of the locust can provide a promising model for collision sensors which could be useful for several technical applications, such as helping blind or visually impaired persons avoid accidents.

References

1. FC Rind FC, DI Bramwell, J Neurophysiol 75 (1996) p. 967.
2. W Denk, H Horstmann, PLoS Biol. 2 (2004) e329.
3. A Zankel et al, J Microsc. 233 (2009) p. 140.

Grant Sponsor: Styrian Provincial Government das Land Steiermark, HTI:SMAApp Programme 2012.

The authors gratefully acknowledge the help of our technicians Ms. Elisabeth Bock, Ms. Gertrud Havlicek, Mr. Bernhard Robinig, and Ms. Claudia Mayrhofer.

Figure 1: SEM micrograph showing the arrangement of afferent neurons (a) along a dendrite of the LGMD. Arrow: Output synapse of one afferent with another afferent and the LGMD as postsynaptic partners.

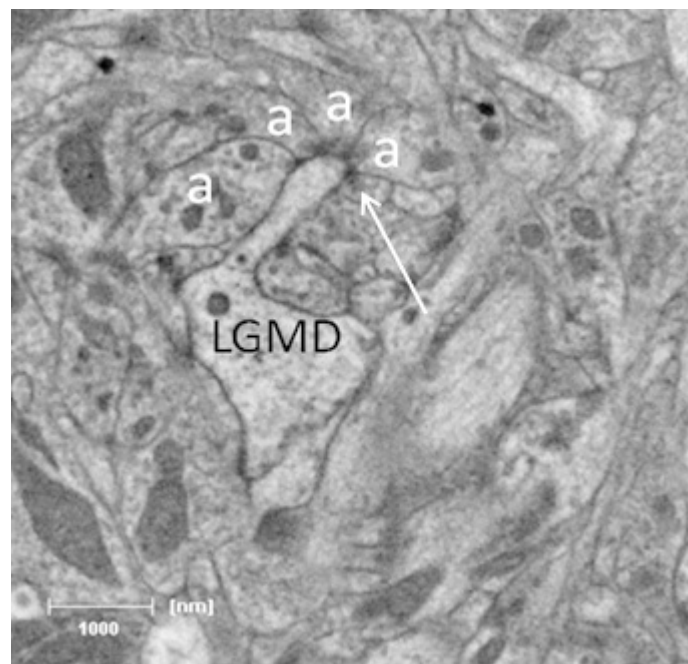

Desert ant's navigation: effects of conflicting celestial compass information

Fleur Lebhardt, Bernhard Ronacher¹

¹Humboldt-Universität zu Berlin, Behavioural Physiology, Invalidenstr. 43, 10115 Berlin, Germany

In the North-African salt pans the desert ants (*Cataglyphis fortis*) navigate during their foraging courses by means of path integration. Leaving the nest they continuously update a "home vector" which allows them to return back to the nest from any point in a direct straight line.

The computation of the home vector relies on two types of information: a compass direction and a distance measurement, by means of a pedometer (Wittlinger et. al 2006, Science 312:1965). As compass the ant uses the sky's polarization pattern or the position of the sun (Müller and Wehner 1988, Proc.Natl.Acad.Sci. USA 85:5287).

It seems that these two compass systems operate independently and that if both cues are available, the ants rely predominantly on the sky's polarization pattern (Wehner and Müller 2006, Proc.Natl.Acad.Sci. USA 103:12575). With our experiments we wanted to investigate how the ants would react in a situation where the sun and the polarization compass provide contradictory directional information. Training the ants in a channel covered with a linear polarizing filter allowed us to present them simultaneously an artificial polarization pattern (a uniform e-vector orientation along the whole training distance) and the actual position of the sun.

Against our expectation on their homebound runs the ants indeed did not behave like ants trained under similar conditions but without view to the sun (Lebhardt et al. 2012, J.Exp.Biol. 215:526). These results suggest that in case of conflicting sky compass information the polarization compass does not longer completely dominate, and that the ants determine their homing direction by combining both celestial compass cues.

Asymmetric polarotactic response of locusts in a tethered flight situation

Johannes Schuh, Uwe Homberg¹, Sarah Grant¹, Ronny Rosner¹

¹Philipps-Universität Marburg, Animal Physiology, AG Homberg, Karl-von-Frisch-Straße 8, 35043 Marburg Marburg, Germany

Bees, ants and butterflies are known to use the polarized light pattern in the sky for spatial orientation (Horváth and Varjú 2004, Polarization vision. Springer, Heidelberg). Polarized light is generated when sunlight is scattered in the atmosphere. The resulting polarization pattern provides information about the position of the sun. Behavioral experiments showed that flies, crickets and locusts also perceive polarized light. When rotating a polarization filter dorsally from the tethered insects and measuring their turning tendency a periodic orientation behavior is observed that is closely linked to the periodic changes of the oscillation plane of light passing the filter.

In recent years part of the neuronal machinery mediating the polarotactic behavior was uncovered (Homberg et al. 2011, Phil Trans R Soc Lond B 366:680). Neurons sensitive to the oscillation plane of polarized light modulate their firing rate in a sinusoidal manner in response to a dorsally rotated polarization filter. This response profile is in contrast to the behavior we observed when measuring the torque response of tethered flying desert locusts, *Schistocerca gregaria*, in a wind tunnel. We found the torque of the locusts to oscillate not in a sinusoidal but in a saw-tooth like manner, consisting of slow pursuit responses in the direction of rotation of the polarizer alternating with fast responses against the rotation direction of the polarizer. Part of this behavior may be explained by neurons that differ in their response to clockwise and counterclockwise rotation of the polarizer. Candidate neurons showing stronger responses to one turning direction of the polarizer than to the opposite were, indeed, found outside the classical polarization vision pathway in the posterior brain and descending from the brain to thoracic ganglia. The data suggest that sky polarization may be used in locusts for detecting yaw in otherwise featureless surroundings. Supported by DFG grant HO 950/16-3.

Topographic organization of the posterior optic tubercle in the locust brain: possible role in the generation of an internal sky compass

Jerome M. Beetz, Basil el Jundi², Stanley Heinze³, Uwe Homberg¹

¹Philipp-Universität Marburg, AG Homberg, Karl-von Frisch Straße 8, 35032 Marburg, Germany

²Department of Biology, University of Lund, 22362 Lund, Sweden

³Department of Neurobiology, University of Massachusetts Medical School, Worcester, MA, 01605, USA

Many insects use the polarization pattern of the blue sky for spatial orientation and navigation. Work in locusts and other species showed that the central complex, a group of neuropils in the center of the brain, plays a key role in processing sky polarization signals. Intracellular recordings from the protocerebral bridge (PB) in the locust brain showed that the tuning of neurons to the electric field vector (*E*-vector) of polarized light correlates with the innervated column, resulting in a compass-like representation of azimuthal directions in the 16 columns of the PB (Heinze and Homberg 2007, *Science* 315:995-997). Neurons responsible for this topographic representation are tangential TB1-neurons that connect the PB and the paired posterior optic tubercles (POTus) in the posterior brain.

To analyze the *E*-vector coding in TB1 neurons in more detail, we have characterized their ramifications in the POTus in detail. Immunostaining of TB neurons with antisera against serotonin, Dip-allatostatin, and Mas-allatotropin showed that about 20 TB1 neurons with somata in two cell clusters exist per brain hemisphere. Innervation of the POTu occurs in a patchy fashion and, in addition, in a layered organization. Neurons innervating an anterior and dorsal layer of the POTu connect to inner and outer columns of the bridge (1,2,7,8) and neurons innervating a posterior and ventral layer connect to intermediate columns (3,4,5,6). Both POTus are interconnected by polarization-sensitive intertubercle neurons. These neurons ramify in the antero-dorsal layer of the POTu in one hemisphere and in the postero-ventral layer in the contralateral hemisphere (el Jundi and Homberg 2010, *J Insect Physiol* 56:971-979). Corresponding to the arborization domains in the POTu a neuronal circuit between TB1 neurons and intertubercle neurons is proposed leading to maintenance of the internal compass in the central complex through contrast enhancement. Supported by DFG grant HO 950/16-3.

Peripheral neural circuits underlying colour discrimination in *Drosophila*

Christopher Schnaitmann, Christian Garbers², Thomas Wachtler², Hiromu Tanimoto¹

¹Max-Planck-Institute of Neurobiology, Behavioural Genetics, Am Klopferspitz 18, 82152 Martinsried, Germany

²Computational Neuroscience, Department Biology II, Ludwig-Maximilians-University, Großhaderner Straße 2, 82152 Martinsried, Germany

A prerequisite for colour vision in an animal is to have multiple types of photoreceptor cells with different spectral sensitivity. The *Drosophila* compound eye has five different photoreceptor cell types with sensitivities ranging from “UV” to “green” light that are differentially distributed in around 800 ommatidia. It has been shown that flies can discriminate visual stimuli based on their spectral composition. However, it is still unknown which photoreceptors types contribute to colour discrimination. We developed a conditioning assay in which flies associate one of two different colour stimuli with sucrose reward. Here we show that the discrimination in this conditioning assay is predominantly based on the wavelengths (colours) of the stimuli, but not their intensity. Using genetic techniques that restrict a combination of active photoreceptor types, we identify photoreceptor types R1-6, R7y, and R8y that feed into colour discrimination. Furthermore, inactivation of postsynaptic neurons reveals the peripheral circuit that is involved in comparing the output of different photoreceptors for colour discrimination.

Visual responsiveness of central-complex neurons in the desert locust *Schistocerca gregaria*

Tobias Bockhorst, Ronny Rosner¹, Uwe Homberg¹

¹Philipps University Marburg, Dept. of Biology, Animal Physiology, Karl-von-Frisch-Straße 8, 35032 Marburg, Germany

The central complex is a set of midline-spanning neuropils in the insect brain playing an increasingly apparent role in motor control and visual integration, particularly visual object discrimination, visual place learning, and spatial orientation (1-4). In desert locusts, central-complex neurons were shown to represent the electric field vector of polarized light in a polarotopic gradient which may act as a sky compass for navigation during long-distance migrations (4).

We performed intracellular recordings with subsequent tracer injections to measure the responsiveness of polarization-sensitive and other identified central-complex neurons to a variety of unpolarized light signals displayed in lateral regions of the visual field. Flashes of different spectral composition served to test general light sensitivity while a variety of object-like light patterns was used to screen for more complex spatio-temporal tuning. Patterns most frequently presented comprise white or black bars varied in length and edge orientation as well as small field patches, displayed either stationary or translating.

In central-complex neurons hitherto encountered, stimulus correlated changes in spiking pattern ranged from stereotypical light responses to more complex and subtle modulations indicative of movement sensitivity or tuning to object positions. Responses were found in polarization-sensitive neurons as well as in non-polarization-sensitive cells. Some recordings from columnar neurons demonstrate tuning to movement direction of targets within small areas of the visual field. The data suggest that a variety of visual qualities are integrated in central-complex neurons consistent with a role of this brain area in visual orientation and visual memory. Supported by DFG grant HO 950/16-3.

References

- [1] Strauss (2002): The central complex and the genetic dissection of locomotor behavior. *Curr Opin Neurobiol* 12: 633-638 [2] Liu et al. (2006): Distinct memory traces for two visual features in the *Drosophila* brain. *Nature* 439: 551- 556 [3] Ofstad, Zuker & Reiser: Visual place learning in *Drosophila melanogaster*. *Nature* 474: 204-209 [4] Homberg U, Heinze S, Pfeiffer K, Kinoshita M, el Jundi B 2011 Central neural coding of sky polarization in insects. *Phil Trans R Soc B* 366:680-687

Impact of octopaminergic modulation on the processing of natural dynamic optic flow in the fly visual system

Diana Rien, Roland Kern¹, Rafael Kurtz¹

¹Bielefeld University, Neurobiology, Postbox 100131, 33501 Bielefeld, Germany

In various species visual information processing has been demonstrated to depend on the animal's locomotor state (review: [1]). The neuromodulator octopamine was shown to affect the response characteristics of optic-flow processing neurons in the fly's visual system in a similar way as flight or walking activity [2-4]. Locomotor activity as well as administration of the octopamine receptor agonist chlordimeform (CDM) modified contrast gain adaptation [5, 6] and velocity coding [2, 4]. These changes resulted into enhanced neuronal responses, in particular during sustained stimulation with high temporal frequencies, and to shorter latencies of the response to an abrupt onset of pattern motion. Here we assess the functional significance of these changes for the processing of the stimuli as experienced during flight. Additionally, we test whether the effects of CDM can be counteracted by the specific octopamine receptor antagonist epinastine [7].

We used a panoramic stimulus device ("FliMax", [8]) to monitor the responses of the V1 neuron in *Calliphora vicina* to naturalistic image sequences, which were reconstructed based on measurements of the body position and gaze orientation during free flight in an arena [9]. Application of CDM resulted in a faster increase in spike rate in response to saccadic flight maneuvers, whereas after epinastine treatment the increase in spike rate was decelerated.

We asked during which types of self-motion the neuronal responses are most affected by octopaminergic modulation. To this aim we scrutinized the self-motion parameters at the time points that are associated with the most prominent response differences between CDM application and subsequent epinastine treatment in the same preparation. These events were typically characterized by an increased rotation velocity of the fly, especially around the pitch axis. This finding is compatible with the previously observed enhancement of the neuronal response by locomotor activity and CDM at high temporal frequencies. Since high temporal frequencies are more likely to occur during locomotion than during rest, such changes might adjust the sensitivity of motion-sensitive neurons to the currently prevailing stimulus qualities. Overall, our neuronal recordings during panoramic replay of naturalistic image sequences indicate that the effects of CDM (and locomotor activity) on neuronal response characteristics, which were so far demonstrated using experimenter-designed stimuli, are functionally relevant under the complex, highly transient stimulus conditions during flight.

1. Maimon G (2011) *Curr Opin Neurobiol* 21:559-564.
2. Jung SN, Borst A, Haag J (2011) *J Neurosci* 31:9231-9237.
3. Longden KD, Krapp HG (2009) *J Neurophysiol* 102:3606-3618.
4. Longden KD, Krapp HG (2010) *Front Syst Neurosci* 4:153.
5. de Haan R, Lee YJ, Nordstrom K (2012) *Front Integr Neurosci* 6:55.
6. Rien D, Kern R, Kurtz R (2012) *Eur J Neurosci*
7. Roeder T, Degen J, Gewecke M (1998) *Eur J Pharmacol* 349:171-177.
8. Lindemann JP, Kern R, Michaelis C, Meyer P, van Hateren JH, Egelhaaf M (2003) *Vision Res* 43:779-791.
9. Schilstra C, van Hateren JH (1998) *J Neurosci Methods* 83:125-131.

Color coding in interneurons of the honeybee

Benjamin H Paffhausen, Randolph Menzel¹

¹Freie Universität Berlin, Neurobiologie, Königin-Luise-Straße 28/30, 14195 Berlin, Germany

Honeybees have a trichromatic color vision with photoreceptors maximally sensitive UV (340 nm), blue (440 nm) and green (540 nm). Although visual interneurons have been studied with respect to their spectral coding properties little is known about the receptive field structures of these neurons. We investigated the receptive fields of high order visual neurons using UV, blue and green LEDs mounted on a software controlled perimeter that allowed to move the LEDs to any position in frontal view of one compound eye. The neurons were recorded extracellularly in the ipsilateral lobula, medulla, anterior optic tubercle or the alpha-lobe of the mushroom body. We found color opponent, wavelength sensitive and wavelength insensitive neurons. One of these wavelength coding cells was not yet described by Yang et al. (2004) and earlier studies. This neuron responded with inhibition to UV and green light and did not respond to blue light. The receptive field structure varied from large receptive fields covering nearly the whole eye to narrow stripe-like fields. Another neuron responded with sequence sensitive inhibition to blue light flashes (inhibitory response only after green light). Our data are interpreted on the basis of psychophysical experiments describing combined color and pattern discrimination in honeybees.

Yang, E. C., Lin, H. C., & Hung, Y. S., 2004 Patterns of chromatic information processing in the lobula of the honeybee, *Apis mellifera* L. *J. Insect Physiol.* 50, 913–925.

Light-induced plasticity of giant synapses in the lateral accessory lobe of the desert ant, *Cataglyphis fortis*

Franziska Veronika Schmitt, Sara Mae Stieb¹, Rüdiger Wehner², Wolfgang Rössler¹

¹University of Würzburg, Biozentrum, Zoology II, 97074 Würzburg, Germany

²University of Zürich, Brain Research Institute, CH-8057 Zürich

The North African desert ant *Cataglyphis fortis* lives in nearly featureless salt pans without reliable landmarks that can be used for visual orientation. To be able to return straight back to the nest entrance after wide-ranging foraging trips, the ants heavily rely on a path integration system including polarized-skylight vision and a visually influenced step counter (Wehner and Wehner 2011, *Physiol Entomol* 36:271; Ronacher and Wehner 1995, *J Comp Physiol A* 177:21). For polarized-skylight reception, the ants possess specialized UV receptors in ommatidia of the dorsal rim area of the eye. Workers show an age-dependent polyethism - while newly emerged callows, interior I and interior II workers fulfill tasks inside the nest for ~28 days, foragers leave the nest to provide the colony with food. The transition from interior workers to outdoor foraging includes a ~3-day period during which the ants perform orientation runs. These runs usually take place within a range of ~30 cm around the nest entrance and are characterized by pirouette-like 360° turns of the ants (Stieb et al. 2012, *Dev Neurobiol* 72:729). We hypothesize that the ant's visual system is trained during the orientation runs. Using iontophoretic dye injections we show that the polarization vision (POL) pathway in the brain of *Cataglyphis fortis* shows great similarities to the well-established POL pathway in the locust (Träger et al. 2008, *J Comp Neurol* 506:288; Homberg et al. 2011, *Philos T R Soc* 366:680). This includes projections to the dorsal lamina, medulla and lobula, the anterior optic tubercle (AOTu), lateral accessory lobe (LAL), and GABAergic tangential neurons terminating in the lower unit of the central complex. AOTu neurons and GABAergic tangential neurons are connected by ~100 characteristic giant synaptic complexes on each side. Comparison between callows and foragers showed that the total number of these giant synaptic complexes increases significantly between the two stages. Since this synaptic pathway was shown to be involved in polarized-skylight information processing, we tested whether synaptic plasticity is mainly triggered by the UV-spectrum. We exposed 1-day old ants in their natural habitat using a light regime of 4 x 45 min over 5 days with one group exposed to light under a UV cut-off filter (UV-group) to exclude polarized light information, one group under a neutral filter (neutral group) adjusting the overall intensity to the UV-group, and dark control group. The brains were dissected, labeled with Lucifer yellow to subsequently visualize, 3D reconstruct and quantify the LAL giant synaptic complexes. The total number of giant synaptic complexes differed between dark kept ants, the UV-group, and the neutral group. While ants that never experienced light exhibited the lowest number of giant synaptic complexes, the ones that experienced the full light spectrum had the highest numbers, and the numbers in UV-group was in between. The results show that structural plasticity in LAL giant synapses is triggered by light exposure, and a subset of synapses triggered by UV exposure. This further suggests the importance of orientation runs for initial calibrations in the polarized-skylight vision pathway.

Distribution patterns of SIFamide in hemimetabolous insects

Andreas Arendt, Julia Schulze¹, Susanne Neupert², Reinhard Predel², Monika Stengl¹

¹University of Kassel, Animal Physiology, Heinrich-Plett-Str. 40, 34132 Kassel, Germany

²University of Cologne, Biocenter Cologne, Functional Peptidomics, Zùlpicher Str. 47b, 50674 Cologne, Germany

The neuropeptide SIFamide shows a particularly high degree of conservation regarding its sequence within the phylum *Arthropoda*. Several isoforms of the peptide have been described in various insects, crustaceans, and a tick showing only little variations at the N-terminus, often only at the first amino acid. The distribution pattern in brains of holometabolous insects showed also striking similarities. In the blowfly *Neobellieria bullata*, the honeybee *Apis mellifera*, and many other insects only four relatively large somata in the *pars intercerebralis* (PI) expressed immunoreactivity against SIFamide. Generally, varicose branchings are widely spread in brains of the adults. Recent studies investigating neuropeptide distribution in *Drosophila melanogaster* located three pairs of additional SIF-immunoreactive (-ir) cell bodies in the dorsolateral protocerebrum. Moreover, in the tobacco hornworm *Manduca sexta* another SIF-ir soma was detected anterior to the calyx, while weakly stained cells were observed dorsally and ventrally. Unfortunately, the peptide is not as well studied in hemimetabolous insects as in the holometabolous group. With antibodies against SIFamide (anti-AYRKPPFNGSIFamide; antibody provided by Dr. Jan Veenstra) we investigated the occurrence of the peptide in the Madeira cockroach *Rhyparobia (Leucophaea) maderae*, the American cockroach *Periplaneta americana*, and the Indian domino cockroach *Therea petiveriana*. In each species, also four big cells in the PI expressed strong immunoreactivity. Furthermore, smaller cells in the PI as well as other groups of soma in the lateral protocerebrum and in close vicinity to the calyx could be observed. Moreover, we identified the Rhm-SIFamide (TYRKPPFNGSIFamide) with matrix-assisted laser desorption/ionization time of flight mass spectrometry in preparations of single glomeruli of the antennal lobe as well as in cell clusters of the PI. The Sequence of the Rhm-SIFamide is identical to previously identified SIFamides in *P. americana*, *Bombyx mori*, *Tenebrio molitor* and *Tribolium castaneum*. To conclude, the highly conserved sequence supports an important physiological function of this peptide. The additional immunoreactive cell groups might represent the originally distribution of SIFamide, which hints to further physiological roles in basal insects that were partially lost during evolution. Future behavioural assays in combination with peptide injections will investigate the role of SIFamide in *R. maderae*, an established model organism in circadian research. [Supported by DFG grant STE531/21-1 to MS]

Neuronal organization of light-entrainment in the Madeira cockroach (*Rhyparobia maderae*)

Julia Schulze, Thomas Schendzielorz¹, Susanne Neupert², Reinhard Predel², Monika Stengl¹

¹University of Kassel, Animal Physiology, Heinrich-Plett-Straße 40, 34132 Kassel, Germany

²University of Cologne, Biocenter Cologne, Functional Peptidomics, Zùlpicher Str. 47b, 50674 Cologne, Germany

Organisms synchronize to the daily light dark cycle via light entrainment pathways from the external Zeitgeber to their circadian clocks. In the Madeira cockroach *Rhyparobia (Leucophaea) maderae* the circadian clock is located to the accessory medulla (AMe) and is especially enriched in neuropeptides with unknown functions. Since injections of orcokinin (ORC) and Mas-allatotropin (AT) as well as the neurotransmitter γ -aminobutyric acid (GABA) revealed light-like phase response curves (PRCs) these neuroactive substances were suggested to function in the light entrainment pathway to the clock. Ipsilateral light information appears to be transmitted to the AMe via GABAergic distal tract and fiber fan neurons and processed by AT-immunoreactive (-ir) interneurons. Photic input from the contralateral eye is apparently provided by ORC-ir AMe neurons to the pacemaker. Previous experiments suggested that neuropeptides of the family of Rhm-myoinhibitory peptides (Rhm-MIPs) play also an important role in transmitting light information to the circadian pacemaker center.

Since the sequence of AT and ORC in the Madeira cockroach has not been determined yet, first two ORCs and the AT of *R. maderae* were identified by using MALDI-TOF mass spectrometry. Second, with immunocytochemistry it was searched for colocalizations between MIP, AT, ORC, and GABA. While no colocalization between MIP- and GABA immunoreactivity (IR) was detected in the distal tract, numerous medulla intrinsic neurons and one median AMe neuron showed colocalization. In addition, colocalization of MIP- and AT IR was detected in somata and noduli of the AMe. In one ventral and one ventromedian AMe neuron colocalized ORC- and MIP IR could be observed. Finally, we performed injections with synthetic Rhm-MIP-1, Rhm-ORCs, and Rhm-AT. Injections of Rhm-MIP-1 resulted in a dose-dependent monophasic PRC with the strongest delay at the beginning of the subjective night, while injections of the other neuropeptides confirmed previously obtained PRCs. To conclude, this study provides new aspects of the light-entrainment pathway in the Madeira cockroach and suggests the involvement of at least one Rhm-MIP in ipsi- and contralateral light entrainment. [Supported by DFG STE531/21-1 to M.S.]

Poster Topic

T15: Vision: Retina and Subcortical Pathways

- T15-1A** Deletion of the ionotropic glutamate receptor subunit GluR4 from horizontal cells of the mouse retina
Sebastian Ströh, Stephan Sonntag, Hannah Monyer, Reto Weiler, Klaus Willecke, Ulrike Janssen-Bienhold, Karin Dedek
- T15-2A** THE PHOTORECEPTOR RIBBON COMPLEX: A PRIMING DEVICE?
Martina Löhner, Angela Peukert, Jenny Atorf, Jan Kremers, Susanne Schoch, Elena Alvarez-Baron, Johann H. Brandstätter, Hanna Regus-Leidig
- T15-3A** Loss- and gain-of-function mutations in the *Cacna1f* gene differentially impact photoreceptor survival and ribbon synaptic function in the mouse retina
Jenny Atorf, Hanna Regus-Leidig, Andreas Feigenspan, Marion A. Maw, Jan Kremers, Johann Helmut Brandstätter
- T15-4A** Are Complexins involved in regulating the availability of vesicles at photoreceptor synaptic ribbons?
Anna Sendelbeck, Michaela Fuchs, Kerstin Reim, Johann Helmut Brandstätter
- T15-5A** Local neuronal circuitry in the chicken optic tectum and modulation by the isthmus system
Stefan Weigel, Matthias Dübbert, Harald Luksch
- T15-6A** Visual system assessment with multifocal electrophysiology – Optic media opacities mimic retinal diseases
Anne Herbig, Gloria C. Hölzl, Juliane Reusch, Michael B. Hoffmann
- T15-7A** Pharmacological manipulation of chloride homeostasis in the retina : Impact on direction selective ON and OFF responses in the rat's nucleus of the optic tract
Katharina Margaretha Spoida, Claudia Distler, Anne-Kathrin Trampe, Klaus-Peter Hoffmann
- T15-8A** Phosphorylation of the horizontal cell-specific connexin Cx53.8 in the fish retina: effects of light, dopamine and all-trans retinoic acid
Sebastian Hermann, Helena Greb, Nadine Mellies, Nina Hoyer, William H. Baldrige, Reto Weiler, Ulrike Janssen-Bienhold
- T15-1B** Detection of cGMP in Mouse Retinal Neurons Using Immunohistochemistry and Live Cell Imaging Based on Genetically Encoded Sensors
Zhijian Zhao, Frank Müller
- T15-2B** What information does the eye send to the brain? Recording the entire visual output at a single

retinal location

Thomas Euler, Philipp Behrens, Matthias Bethge, Tom Baden

- T15-3B** Receptive field properties of neurons in the optic tectum of chicken (*Gallus Gallus*)
Josine Verhaal, Harald Luksch
- T15-4B** Beyond Colour Vision: Dichromacy Provides for Optimal Sampling of Contrast Statistics in Natural Scenes
Timm Schubert, Tom Baden, Le Chang, Tao Wei, Mariana Zaichuk, Bernd Wissinger, Euler Thomas
- T15-5B** Probing visual receptive fields at single synapse resolution
Katrin Franke, Thomas Euler, Tom Baden
- T15-6B** Image stabilisation through non-linear retinal processing
Garrett Greene, Erica Ehrhardt, Tim Gollisch, Thomas Wachtler
- T15-7B** Modulation of Response Properties in Retinal Ganglion Cells by Remote Stimulation
Vidhyasankar Krishnamoorthy, Tim Gollisch
- T15-8B** Spatial integration in the receptive field surround of retinal ganglion cells
Daisuke Takeshita, Tim Gollisch
- T15-9B** Complement deposition in an experimental autoimmune model of glaucoma in rats
Sabrina Reinehr, Sebastian Becker, Sandra Kühn, Christina Casola, Mathias Kühn, Burkhard Dick, Stephanie C. Joachim
- T15-1C** Morphology and micro-projection pattern of the cells of origin of the descending Tecto-GLV pathway in the chicken (*Gallus gallus*)
Tomas Vega-Zuniga, Vanessa Marks, Stefan Weigel, Harald Luksch
- T15-2C** Spatial Integration of Subunits in Mouse Retinal Ganglion Cells
Michael Weick, Daisuke Takeshita, Tim Gollisch
- T15-3C** Spike-Triggered Analysis of Contrast Adaptation in the Retina
Jian Liu, Tim Gollisch
- T15-4C** Connexin interactions in the inner retina of the mouse
Arndt Meyer, Birthe Dorgau, Sheriar G Hormuzdi, Klaus Willecke, Reto Weiler, Karin Dedek
- T15-5C** Use of multi electrode arrays for recordings of retinal ganglion cell activity in CACNA1F mutant mouse models
Klaus Schicker, Dagmar Knoflach, Eduardo Fernandez, Peter Ahnelt, Alexandra Koschak
- T15-6C** Visual capabilities, visual plasticity and collicular maps in “cortexless” *Esco2*-mutant mice
Evgenia Kalogeraki, Verena Günther, Gabriela Whelan, Fred Wolf, Gregor Eichele, Siegrid Löwel

- T15-7C** Classifying retinal ganglion cells using responses to naturalistic stimuli
Fernando Rozenblit, Tim Gollisch
- T15-8C** Functional properties of spontaneous synaptic events in horizontal cells of the mouse retina
Andreas Feigenspan
- T15-9C** Rhythmic ganglion cell activity in bleached or blind mouse retinae
Henrike Stutzki, Jacob Menzler, Günther Zeck
- T15-1D** Spatial Contrast Adaptation in Mouse Retina
Mohammad Hossein Khani, Vidhyasankar Krishnamoorthy, Tim Gollisch
- T15-2D** Retinal topography and central visual projections of a palaeognath bird, the Chilean Tinamou (*Nothoprocta perdicaria*)
Quirin Krabichler, Harald Luksch, Tomas Vega-Zuniga, Gonzalo J. Marín, Cristian Morales, Jorge Mpodozis
- T15-3D** How retinal ganglion cells encode object motion and motion direction
Norma Kühn, Tim Gollisch
- T15-4D** A New Psychophysiological Model of Absolute Visual Thresholds in Man
Werner Georg Karl Backhaus
- T15-5D** Structure-function relationship of direction-selective cell types in the optic tectum of larval zebrafish
Johann H Bollmann, Chintan A Trivedi, Fabian Svara, Colette M Maurer, Soojin Ryu, Jens P Gabriel
- T15-6D** Ganglion cell mosaics and their potential influence on orientation preference maps
Manuel Schottdorf, Wolfgang Keil, Fred Wolf
- T15-7D** Early multisensory interaction revealed through simultaneous inter-areal recordings in the ferret midbrain
Iain Maurice Stitt, Edgar Galindo-Leon, Florian Pieper, Gerhard Engler, Andreas K. Engel
- T15-8D** Retracted

Deletion of the ionotropic glutamate receptor subunit GluR4 from horizontal cells of the mouse retina

Sebastian Ströh, Stephan Sonntag², Hannah Monyer³, Reto Weiler¹, Klaus Willecke², Ulrike Janssen-Bienhold¹, Karin Dedek¹

¹University of Oldenburg, Dept. of Neurobiology, 26111 Oldenburg, Germany

²University of Bonn, Life and Medical Sciences Institute, D-53115 Bonn, Germany

³University Hospital of Neurology, Dept. of Clinical Neurobiology, D-69120 Heidelberg, Germany

Horizontal cells are second order neurons of the vertebrate retina which receive glutamatergic inputs from photoreceptors via ionotropic glutamate receptors (GluR). Horizontal cells shape the receptive fields of photoreceptors, bipolar and ganglion cells and play a crucial role in retinal adaptation to ambient light by feeding back inhibition to photoreceptors. Although horizontal cell functions are well characterized, their underlying mechanisms are not completely understood. To be able to investigate horizontal cell function more precisely, a mouse line was developed which expresses the enzyme Cre recombinase exclusively in horizontal cells. This was achieved by using the connexin57 (Cx57) promoter, as the gap junction protein Cx57 couples mouse horizontal cells and has not been found in any other cell type of the murine retina so far.

To test whether this mouse line (Cx57+/Cre) can be used to delete genes in a horizontal cell specific manner, we crossbred it with a transgenic mouse line in which the gene for the ionotropic glutamate receptor channel subunit GluR4 was flanked by loxP sites (GluR4fl/fl), the target sites of the Cre recombinase. To analyze the effects, we quantified the GluR4 immunoreactivity in the outer and inner retina of GluR4fl/fl-Cx57+/Cre and control mice. Whole-cell patch-clamp recordings from dissociated horizontal cell somata were performed to test the response to glutamate receptor agonists and antagonists.

Using double immunolabeling for Cre recombinase and the horizontal cell marker calbindin, we found Cre recombinase expression in every calbindin-positive horizontal cell while no other cell type was Cre-positive. Labeling with antibodies against GluR4 showed that the expression of GluR4 in the outer retina was strongly reduced in GluR4fl/fl-Cx57+/Cre mice. Consistent with a cell type-specific deletion, no changes in GluR4 immunoreactivity were observed in the inner retina. Using patch-clamp recordings and a slow drug application system, we estimated the effect of glutamate receptor agonists on horizontal cell somata. In control mice, we determined an EC₅₀ value for glutamate of 130 μ M, for AMPA (α -Amino-3-hydroxy-5-methyl-4-isoxazol propionic acid) of 30 μ M, and for kainic acid of 100 μ M, respectively, from steady state inward currents. We also measured GluR agonist-induced currents in horizontal cells from GluR4fl/fl-Cx57+/Cre mice. Consistent with our immunolabeling experiments, AMPA, kainic acid and glutamate-induced currents were reduced by about 85 % when compared to control mice. The residual inward current was almost completely blocked by GYKI52466, a selective AMPA receptor antagonist, suggesting that most of the glutamate-induced response is driven by AMPA receptor channels. The residual GYKI52466-insensitive current was completely blocked by CNQX, a selective AMPA and kainate receptor antagonist, indicating that there are no other glutamate receptor channel classes expressed in murine horizontal cell somata.

In summary, our immunolabeling and patch-clamp experiments show that it is possible to ablate proteins from mouse horizontal cells in a cell-type specific manner. This makes the Cx57-Cre mouse line a useful tool to study horizontal cell function in greater detail. For example, it could be shown, that GluR4 likely is the major contributor to the glutamate response of mouse horizontal cells.

This work was supported by a grant from the Deutsche Forschungsgemeinschaft to K.D. and U.J.B.

(DE1154/3-1).

THE PHOTORECEPTOR RIBBON COMPLEX: A **PRIMING** DEVICE?

Martina Löhner, Angela Peukert¹, Jenny Atorf², Jan Kremers², Susanne Schoch³,
Elena Alvarez-Baron³, Johann H. Brandstätter¹, Hanna Regus-Leidig¹

¹Animal Physiology, Dep. Biology, University Erlangen-Nuremberg, 91058 Erlangen, Germany

²Ophthalmology, University Hospital Erlangen, 91058 Erlangen, Germany

³Epileptology, University of Bonn, 53105 Bonn, Germany

RIM (Rab3-interacting molecules) proteins are essential components of the active zones of chemical synapses, interacting with most other active zone-enriched proteins as well as synaptic vesicle proteins. They are suggested to play important roles in exocytosis, especially during vesicle priming. The RIM protein family includes seven members encoded by four genes – two α -RIMs (RIM1a and 2a), two β -RIMs (RIM1 β and 2 β) and three γ -RIMs (RIM2 γ , 3 γ and 4 γ)–, which diverge in their structural composition and mediate distinct and to some extent redundant functions. Still a matter of debate is the localization and possible function of RIM isoforms at the highly specialized photoreceptor ribbon synapse.

We analyzed the expression profiles of RIM1 and RIM2 α / β - isoforms in cortex and retina as well as in isolated ribbon-containing cells of the retina with RT-PCR and revealed the α -isoforms as the predominant RIMs in photoreceptors. With immunocytochemistry we investigated the localization of RIM1 and RIM2 at the photoreceptor ribbon complex. In contrast to previous studies, we were not able to detect either of the RIM proteins at the ribbon but at the arciform density. To gain further insight into the roles of the RIM α -isoforms at the photoreceptor ribbon complex, we examined wild-type, RIM1a- and RIM2a-Knockout (KO) mice with electron microscopy for ultrastructural and with electroretinographic recordings (ERG) for functional analyses. Surprisingly, both KO mice showed no structural phenotype, and only the RIM2a-KO-mouse showed a slight decrease in the scotopic ERG b-wave amplitude.

Since the results from the immunocytochemical stainings with the available RIM antibodies, which do not distinguish between the RIM α and β isoforms, were similar in all three genotypes, we will check with quantitative PCR analyses whether a compensatory up-regulation of the respective β - isoforms may account for the missing synaptic phenotype.

Finally we identified a third RIM-isoform, RIM3, at the photoreceptor presynapse. Different from RIM1 and RIM2, RIM3 localizes directly to the photoreceptor synaptic ribbon and not to the arciform density.

Supported by a grant of the DFG (BR 1643/4-2) to J.H.B and H.R.-L.

Loss- and gain-of-function mutations in the ***Cacna1f*** gene differentially impact photoreceptor survival and ribbon synaptic function in the mouse retina

Jenny Atorf, Hanna Regus-Leidig², Andreas Feigenspan², Marion A. Maw³, Jan Kremers¹, Johann Helmut Brandstätter²

¹University Hospital Erlangen, Experimental Ophthalmology, Erlangen, Germany ²Department of Biology, Animal Physiology, FAU Erlangen-Nuremberg, Erlangen, Germany ³Department of Biochemistry, University of Otago, Dunedin, New Zealand

Light-dependent conductance changes of voltage-gated $\text{Ca}_v1.4$ channels regulate neurotransmitter release at photoreceptor ribbon synapses. Mutations in the *CACNA1F* gene encoding the pore-forming $\alpha 1F$ subunit protein of $\text{Ca}_v1.4$ channels cause an incomplete form of human X-linked congenital stationary night blindness (CSNB2). Most mutations are loss-of-function mutations resulting in non-functional $\text{Ca}_v1.4$ channels, but some mutations alter the gating properties of the channels and thus the Ca^{2+} influx at photoreceptor ribbon synaptic active zones. Recently, a novel *CACNA1F* mutation (I745T) was identified in a New Zealand family with an uncommonly severe CSNB2-like phenotype, and in vitro measurements predicted a gain-of-function shift of the current-voltage dependence to more negative membrane potentials. To gain insight into the pathomechanism that could explain the severity of the New Zealand disorder, we generated a mouse model with the corresponding mutation in the murine *Cacna1f* gene (I756T) and compared it with a previously published mouse model with a loss-of-function mutation ($\Delta\text{Ex}14-17$). While in $\Delta\text{Ex}14-17$ mutants the b-wave of the electroretinogram was absent and ribbon synapses were degenerated, I756T mutants revealed a considerable number of intact ribbon synapses and a residual scotopic b-wave. However, in I756T mutants intracellular photoreceptor Ca^{2+} concentrations were elevated and photoreceptor cell loss was significantly accelerated compared to $\Delta\text{Ex}14-17$ mutants. Our findings from mouse suggest that the greater severity of the CSNB2-like phenotype in patients with *CACNA1F* gain-of-function mutations might be caused by increased intracellular Ca^{2+} levels leading to photoreceptor cell death and impaired vision.

Are Complexins involved in regulating the availability of vesicles at photoreceptor synaptic ribbons?

Anna Sendelbeck, Michaela Fuchs¹, Kerstin Reim², Johann Helmut Brandstätter¹

¹Department of Biology, Animal Physiology, FAU Erlangen-Nuremberg, 91058 Erlangen, Germany

²Department of Molecular Neurobiology, Max Planck Institute of Experimental Medicine, 37075 Göttingen, Germany

Photoreceptor ribbon synapses are highly specialized chemical synapses, which transmit light signals over a wide range of intensities and continuously adjust their synaptic output to changing input. Such a level of performance requires complex adaptive mechanisms. Light triggered remodeling of the synaptic ribbon was a long time favored mechanism for adapting the photoreceptor ribbon synapse to changing light conditions. Recently, however, we demonstrated that this cannot be regarded as a general mechanism for light adaptation at retinal photoreceptor ribbon synapses (Fuchs et al., 2012). Therefore the question remains how the release of neurotransmitter at the ribbon synapse is adjusted to changing light conditions.

Jackman et al. (2009) introduced a novel hypothesis for photoreceptor ribbon synaptic function and adaptation. Examining cone photoreceptor ribbon synapses of the lizard *Anolis sagrei*, they found that in the dark the base of the ribbons was depleted of synaptic vesicles, and in the light, when exocytosis stops, ribbons were reloaded with vesicles. This result led to the intriguing idea that the ribbon behaves like a capacitor, charging with vesicles in light and discharging in a phasic burst at light offset. Such a mechanism would extend the operating range of the synapse and encode changes in light intensity more accurately.

In electron micrographs we examined the distribution of vesicles at the photoreceptor synaptic ribbon of light and dark adapted C57BL/6 mice. While the total number of vesicles was comparable, we found significant differences in their distribution along the ribbon. In the dark, vesicles were distributed uniformly along the ribbon. In the light, the base of the ribbon was almost free of vesicles.

Analyzing light and dark adapted Cplx 3/4 double-knockout mice, we were not able to detect the differences in vesicle distribution observed in C57BL/6 mice. In the light and in the dark, comparable numbers of vesicles were distributed uniformly along the synaptic ribbon.

We therefore conclude that the Cplx3 and 4 are involved in a process regulating the availability of vesicles at photoreceptor synaptic ribbons and thus may play a role in light adaptational processes. We currently analyze Cplx 3 and 4 single-knockout mice to determine whether both or only one of the Cplx3 are decisive in this process. Most importantly, however, we want to decipher the causal relationship between Cplx3 and the availability of vesicles at the photoreceptor ribbon synapse.

Supported by a DFG grant to J.H.B. (BR1643/5-1).

Local neuronal circuitry in the chicken optic tectum and modulation by the isthmic system

Stefan Weigel, Matthias Dübbert¹, Harald Luksch¹

¹Technische Universität München, Zoology, Liesel-Beckmann Strasse 4, 85354 Freising, Germany

The dorsal midbrain (superior colliculus in mammals, optic tectum in other vertebrates) is involved in the processing of multimodal sensory information. Here, all available sensory modalities are integrated to a topographic space map and relayed to further processing areas in the fore- and hindbrain. That information is used to generate e.g. saccadic movements or bottom-up attention [1-3]. In birds, the optic tectum (TeO) consists of fifteen layers. Retinal afferents contact neurons in the layers 1-4, 5 & 7 (retinorecipient layers). Other sensory modalities are presumably relayed onto the deeper layers (12-15). Output neurons in layer 13 transmit information from the TeO via the thalamic nucleus rotundus towards the forebrain [4].

Many studies so far have studied the development, cytoarchitecture, and physiology of the TeO. However, less is known about the physiology and connectivity on the level of single cells. We are interested in the architecture and function of local midbrain neuronal networks, in particular in the signal processing between the different layers of the TeO and between the TeO and the nuclei isthmi (NI). The latter consists of three subdivisions: the nucleus isthmi pars parvocellularis (IPC), the n.i. pars magnocellularis (IMC) and the n.i. pars semilunaris (SLU). The three nuclei are heavily interconnected and have reciprocal connectivity with the optic tectum, thus forming exclusive feedback loops of a complex architecture. This system is presumably responsible for stimulus selection via a “winner-takes-all” mechanism and novelty preference [5].

We recently applied optical imaging techniques with voltage sensitive dyes to the chicken midbrain slice preparation. Midbrain neurons were activated by electrical stimulation in the retinorecipient layers of the TeO, which mimics the input from retinal ganglion cells. Stimulation of the tectum resulted in a long-lasting response consisting of a strong transient and a weaker persistent part of mainly postsynaptic origin. This neuronal activity is strongly regulated by inhibition [6].

To study this complex activity pattern into more detail, we have isolated the influence of parts of the network by pharmacological inactivation of neurotransmitter (glutamate, acetylcholine and GABA) and quantified the activity changes in the TeO. We have furthermore tested the influence of the isthmic nuclei on tectal responses. By combining the physiology with known anatomical data we propose a putative circuitry of the local connectivity in the TeO.

References

1. Gruberg E, Dudkin E, Wang Y, Marin G, Salas C, et al. (2006) Influencing and interpreting visual input: the role of a visual feedback system. *J Neurosci* 26: 10368-10371.
2. Luksch H (2009) Optic Tectum: Sensorimotor Integration. In: Squire LR, editor. *Encyclopedia of Neuroscience*: Oxford: Academic Press. pp. 263-269.
3. Stein BE, Stanford TR, Rowland BA (2009) The neural basis of multisensory integration in the midbrain: its organization and maturation. *Hear Res* 258: 4-15.
4. Luksch H (2003) Cytoarchitecture of the avian optic tectum: neuronal substrate for cellular computation. *Rev Neurosci* 14: 85-106.

5. Wang Y, Luksch H, Brecha NC, Karten HJ (2006) Columnar projections from the cholinergic nucleus isthmi to the optic tectum in chicks (*Gallus gallus*): a possible substrate for synchronizing tectal channels. *J Comp Neurol* 494: 7-35.
6. Weigel S, Luksch H (2012) Spatiotemporal analysis of electrically evoked activity in the chicken optic tectum: a VSDI study. *Journal of Neurophysiology* 107: 640-648.

Visual system assessment with multifocal electrophysiology – Optic media opacities mimic retinal diseases

Anne Herbig, Gloria C. Hölzl^{1,2}, Juliane Reupsch¹, Michael B. Hoffmann¹

¹Ophthalmology, Otto-von-Guericke-University Magdeburg, Visual Processing Laboratory, Leipziger Straße 44, 39120 Magdeburg, Germany

²Institute for Biology, Otto-von-Guericke-University Magdeburg, Germany

Objective: To assess differential effects of image quality and optic media opacities on multifocal electroretinograms (mfERGs) and visually evoked cortical potentials (mfVEPs) different types of filter were used to induce image degradations and to simulate optic media opacities in normal participants. MfERGs and mfVEPs provide a topographical account of visual function and thus support the clinical diagnosis of ophthalmological diseases. Especially for the investigation of elderly participants it is of great importance to take the effects of image degradations on multifocal recordings into consideration to avoid misinterpretations of the obtained recordings.

Methods: Using VERIS Science 5.01.12X (EDI, CA, USA) monocular flash-mfERGs and pattern-reversal mfVEPs were recorded in a total of ten participants with normal vision for four different viewing conditions: normal viewing, 8% luminance, 50% luminance, 50% luminance plus blur. The later condition simulated optic media opacities typical for patients with advanced cataract. For mfERG recordings stimulus patterns comprised 61 hexagons scaled with eccentricity (visual field: horizontal 33°/vertical 29° diameter), for mfVEP recordings they comprised 60 individual fields of a circular dartboard pattern (visual field: 31° diameter). For a quantitative assessment mfERG amplitudes and implicit times were determined for the first positive deflection (P1) [1] and mfVEPs root-mean-square (RMS) and signal-to-noise-ratio-values (SNR) were calculated [2].

Results: Reducing stimulus luminance down to 50% and 8% reduced only mfERG responses, namely by 86% and 42%; P1 implicit times were increased for mfERGs by 0.9 and 6.0 ms, respectively. Delays for mfVEPs were increased by 1.0 and 6.3 ms, respectively. For “50% luminance plus blur” the mfERG amplitudes were significantly reduced for the central two eccentricities and enhanced for the peripheral two, while mfVEP RMSs were reduced irrespective of eccentricity close to noise level.

Conclusions: In clinically motivated examinations optic media opacities have to be considered as a potential source of discrepancies between mfERGs and mfVEPs. Especially image blur, a typical trait of cataract, has the potential to change the shape of response topography. This effect may lead to misinterpretations by uninformed clinicians. For example, optic media opacities could be mistaken as a macular pathology (mfERG) or as a general visual field defect (mfVEP).

Supported by the Deutsche Forschungsgemeinschaft (DFG HO-2002/9-1)

[1] Hood DC, Bach M, Brigell M, Keating D, Kondo M, Lyons JS, et al. ISCEV standard for clinical multifocal electroretinography (mfERG) (2011 edition). Documenta ophthalmologica. 2012;124:1-13.

[2] Hood DC, Greenstein VC. Multifocal VEP and ganglion cell damage: applications and limitations for the study of glaucoma. Prog Retin Eye Res. 2003;22:201–51.

Pharmacological manipulation of chloride homeostasis in the retina : Impact on direction selective ON and OFF responses in the rat's nucleus of the optic tract

Katharina Margaretha Spoida, Claudia Distler¹, Anne-Kathrin Trampe¹, Klaus-Peter Hoffmann²

¹Ruhr-University Bochum, General Zoology and Neurobiology, Universitaetsstr. 150, 44801 Bochum, Germany

²Ruhr-University Bochum, Tierphysiologie, Universitaetsstr. 150, 44801 Bochum, Germany

In the present study we investigated *in vivo* the influence of chloride homeostasis in the retina on direction selective response properties of retinal slip cells in the rat's nucleus of the optic tract and dorsal terminal nucleus (NOT-DTN), the essential visuomotor interface coding for slow phase eye movements during the optokinetic reflex. Recent evidence indicates the importance of starburst amacrine cells (SACs), located presynaptically to direction selective retinal ganglion cells, in the generation of retinal direction selectivity. The asymmetrical distribution of chloride equilibrium potential along the dendrites of SACs, mediated by the expression of different cation-chloride-cotransporters, seems to play an important role in the emergence of direction selectivity in the retina.

The application of either a large dark or light edge as a moving stimulus allowed to distinguish between direction selective ON and OFF responses. To exclude that the origin of the retinal slip cells' unexpected OFF response is derived from higher cortical structures, we inactivated the visual cortex by cooling. Cortical cooling had no effect on the direction selectivity of the ON or the OFF response in NOT-DTN retinal slip cells. Disturbing the retinal chloride homeostasis by intraocular injections of bumetanide, a selective NKCC blocker or furosemide, an effective KCC2 inhibitor, led to a loss of direction selectivity in both the NOT-DTN's ON and the OFF response due to a reduced response in the neuron's preferred direction under bumetanide as well as under furosemide and a slightly increased response in the null direction under bumetanide.

Our results indicate that the direction specificity of retinal slip cells in the NOT-DTN of the rat strongly depends on intraretinal chloride homeostasis which was shown to be important for retinal direction selectivity (Gavrikov et al., PNAS 100: 16047-16052, 2003; Gavrikov et al., PNAS 103: 18793-18798, 2006). On top of the well established input from ON center direction selective ganglion cells we could demonstrate an equally effective input from the retinal OFF system to the NOT-DTN.

Phosphorylation of the horizontal cell-specific connexin Cx53.8 in the fish retina: effects of light, dopamine and all-trans retinoic acid

Sebastian Hermann, Helena Greb¹, Nadine Mellies¹, Nina Hoyer¹, William H. Baldrige², Reto Weiler¹, Ulrike Janssen-Bienhold¹

¹University of Oldenburg, AG Neurobiology, Carl von Ossietzky Straße 9-11, 26129 Oldenburg, Germany²Department of Anatomy and Neurobiology, Laboratory for Retina and Optic Nerve Research, Dalhousie University, Halifax, Nova Scotia, Canada

The carp (cp) retina contains four types of horizontal cells (HCs) that are coupled by homologous gap junction channels. Several electrophysiological and tracer-coupling studies revealed that HC coupling is modulated by ambient light levels and that dopamine (DA) and other neuromodulators, such as nitric oxide and all-trans retinoic acid (at-RA) are involved. It is a matter of debate whether these neuromodulators exert their effects via phosphorylation of the gap junction channel-forming proteins, the connexins (Cx). Progress has been hampered by the lack of appropriate HC-specific connexin antibodies. We identified four highly homologous connexins expressed in carp HCs and generated an antibody against one of these connexins, termed cpCx53.8.

By means of immunoblotting we found that light adaptation as well as the incubation of dark-adapted retinas with DA (500 μ M) or at-RA (10 μ M) led to a considerable phosphorylation of cpCx53.8, visible in form of newly appearing immunoreactive isoforms. We tested specific inhibitors of different protein kinases (PK) and found that dopamine effects could be inhibited by preincubation of the retina with the specific PKA-inhibitor H89 (2 μ M) and the D1 dopamine receptor antagonist Schering23390 (10 μ M). Incubation of dark-adapted retinas with phorbol 12,13-dibutyrate (1 μ M), a potent activator of protein kinase C (PKC), resulted in a very prominent phosphorylation of cpCx53.8 and identified it as a substrate for PKC. Interestingly, staurosporine, a potent inhibitor of PKC, was able to inhibit the at-RA-induced phosphorylation. This clearly indicates for the first time that at-RA exerts its effects on HC coupling via the activation of PKC.

To correlate physiological characteristics of HC coupling with the biochemical findings, we performed intracellular recordings and neurobiotin injections. We could show that DA and at-RA incubation of a dark-adapted retina led to a strong decrease of HC coupling and HC receptive field size. These effects were comparable to those induced by light adaptation and could be inhibited by pre-incubation of the dark-adapted retina with the specific PK inhibitors (H89, staurosporine), respectively.

In summary, our data show for the first time that a HC-specific connexin (cpCx53.8) is a substrate for PKA and PKC. Thus, light reduces HC coupling via (1) the DA, DAR1, cAMP, PKA-pathway or (2) the at-RA, PKC-pathway. In either case, light adaptation finally leads to the phosphorylation of cpCx53.8 and closure of the gap junction channel.

Detection of cGMP in Mouse Retinal Neurons Using Immunohistochemistry and Live Cell Imaging Based on Genetically Encoded Sensors

Zhijian Zhao, Frank Müller¹

¹Institute of Complex Systems, Forschungszentrum Jülich, Germany, Cellular Biophysics, Wilhelm-Johnen-Strasse, 52428 Jülich, Germany

Cyclic guanosine monophosphate (cGMP) is a second messenger that plays an important role in many intracellular signaling processes, such as vasodilation or phototransduction in vertebrate photoreceptors. The intracellular cGMP concentration is controlled by two factors: synthesis and degradation. Guanylate cyclases (GCs) catalyze cGMP synthesis by converting GTP to cGMP. Peptide hormones such as the atrial natriuretic peptide (ANP) activate membrane-bound particulate guanylate cyclase (pGC), while soluble guanylate cyclase (sGC) is typically activated by nitric oxide (NO). cGMP is degraded by phosphodiesterases (PDEs).

Recent evidence suggests that cGMP is involved in a variety of neuronal processes. In the vertebrate retina cGMP is not only important in phototransduction. In neurons forming the neuronal network in the inner retina, cGMP seems to be synthesized mainly by sGCs upon stimulation by NO. We investigated the NO-cGMP pathway in the mouse retina using immunohistochemistry. Upon incubation of the retina with NO donors *in vitro*, the retina was fixed and an antibody against cGMP was applied to visualize cGMP-like immunoreactivity in identified retinal cell types, in particular in bipolar cells (Fig. A). However, while this method allows identification of cGMP-positive cell types, it does not reveal the dynamics of cGMP metabolism.

We, therefore, tried to visualize cGMP using live cell imaging. The genetically encoded cGMP-specific sensor protein “cygnet” consists of a cGMP binding site flanked by the two fluorescent proteins CFP and YFP designed for Förster resonance energy transfer (FRET). We characterized the sensor in HEK293 cells expressing the membrane-bound GC-A which can be activated by ANP. Application of ANP leads to a reversible change in the ratio of CFP and YFP fluorescence, indicating an increase in the intracellular cGMP concentration (Fig.B).

To express genetically encoded sensors in retinal cells, we are currently establishing adeno-associated viruses (AAV) as gene ferries in both retinal cultures and *in vivo*.

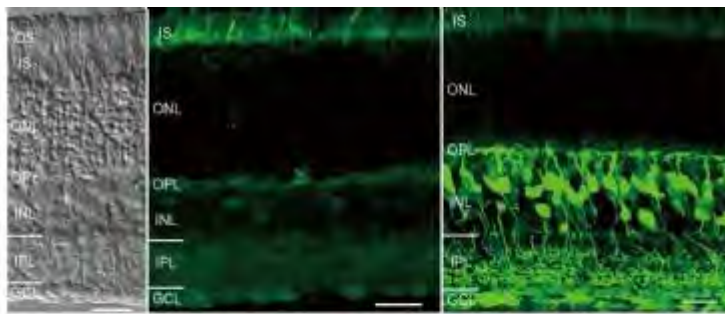

Fig. A cGMP-like immunoreactivity in the mouse retina under control condition (middle) and upon stimulation by NO (right)
Scale bar = 20 μm

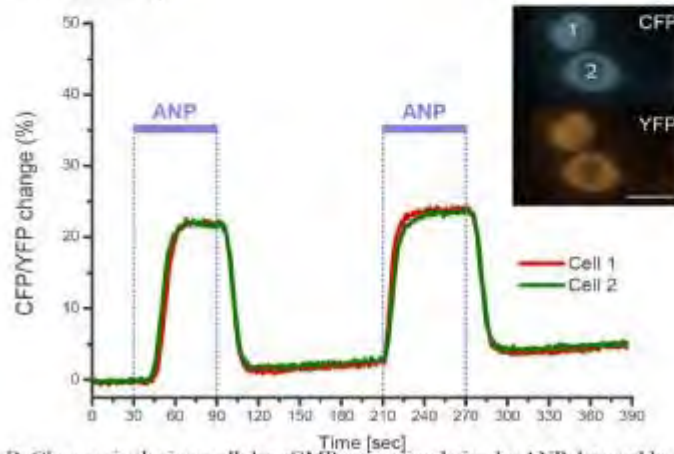

Fig. B Changes in the intracellular cGMP upon stimulation by ANP detected by the cGMP sensor
Scale bar = 20 μm

What information does the eye send to the brain? Recording the entire visual output at a single retinal location

Thomas Euler, Philipp Behrens^{1,2}, Matthias Bethge^{1,2}, Tom Baden^{1,2}

¹Centre for Integrative Neuroscience (CIN)

²Bernstein Center for Computational Neuroscience Tübingen; both: University of Tübingen, Otfried-Müller-Str. 25, 72072 Tübingen

Right at the first synapse in the mammalian retina, the stream of incoming visual information is split into multiple parallel information channels, preprocessed in the retinal network and relayed to the brain via different types of retinal ganglion cells (RGCs). About 20 different morphological RGC types have been described, with each RGC population tiling the retinal surface with its dendritic arbors. Here, we simultaneously record from all RGC types at one retinal location to obtain a complete sample of the information sent to the brain and to understand how the representation of spatio-temporal information in a local image patch is distributed across different RGC types. Here show that retinal ganglion cells can be clustered into functionally defined classes based on their Ca^{2+} -responses to simple light stimuli. We recorded light-evoked Ca^{2+} activity at single-cell resolution from groups of more than 500 neighboring RGCs loaded with synthetic Ca^{2+} indicator dyes in whole-mounted mouse retina using two-photon (2P) microscopy. We used a simple full-field light stimulus composed of luminance changes and a temporal frequency chirp. Over 80% of the cells responded reliably to the full field stimulus. Single cell activity patterns could be clustered into more than 15 functionally distinct types using a simple k-means algorithm, yielding about 40% ON cells, 25% ON/OFF and 15% OFF cells, in agreement with previous reports. In addition, presentation of spatially modulated stimuli such as moving bars and checker-boards allowed us to quickly and reliably identify different previously described functional types such as direction selective RGCs. We will further verify the functional clustering by morphological identification or patch-clamp recordings. This is possible because the imaged RGCs remain accessible to micro-electrodes and, thus, can be dye-filled for morphological identification or targeted for patch-clamp recordings, in contrast to multi-electrode recordings. We now aim to refine our battery of simple stimuli to be able to functionally cluster all >20 morphologically described RGCs in the mouse retina. Our approach allows us to create an inventory of all retinal ganglion cells present at a single retinal location. This local retinal "information fingerprint" should be very informative, not only for our understanding of neuronal computations in the healthy retina, but also as a research tool for evaluating specific functional deficiencies in diseased or degenerating retinae. Acknowledgements: This work was funded by the Bernstein Center for Computational Neuroscience Tübingen (FKZ 01GQ1002) and the Center for Integrative Neuroscience (EXC307).

Receptive field properties of neurons in the optic tectum of chicken (*Gallus Gallus*)

Josine Verhaal, Harald Luksch¹

¹Technische Universität München, Lehrstuhl für Zoologie , Liesel-Beckmann-Straße 4, 85354 Freising-Weihenstephan, Germany

The optic tectum plays a key role in visual processing in birds. While the input from the retina is topographic in the superficial layers, the deeper layers project to the thalamic rotundus in a functional topographical manner.

Although the receptive field of tectal neurons in birds has been mapped before, a high resolution description of the white and black subfields of the receptive field of tectal neurons is still missing. Therefore we measured the receptive fields of neurons among the different layers of the tectum with black and white stimuli which were flashed on a grey background in fast progression.

Our results show that neurons in the middle and deeper layers of the optic tectum tend to respond stronger to black stimuli compared to white stimuli. In addition, the receptive field sizes are larger when measured using black stimuli than with white stimuli and this difference increases with tectal layer depth. Finally, we investigated the optimal stimulus size and found that cells respond best to small white stimuli and to large black stimuli.

We propose that such a magnification of responses to black stimuli within the tectum could be due to recurrent loops within the tectum.

Beyond Colour Vision: Dichromacy Provides for Optimal Sampling of Contrast Statistics in Natural Scenes

Timm Schubert, Tom Baden^{1,3}, Le Chang¹, Tao Wei¹, Mariana Zaichuk¹, Bernd Wissinger², Euler Thomas¹

¹CIN - Centre for Integrative Neuroscience Institute for Ophthalmic Research, Ophthalmic Research, University of Tübingen, Otfried-Müller-Str. 25, 72076 Tübingen, Germany

²Molecular Genetics Laboratory, Centre for Ophthalmology; University of Tübingen, Röntgenweg 11, 72076 Tübingen, Germany

³These authors contributed equally to this work

For efficient coding, sensory systems need to adapt to the distribution of signals to which they are exposed. In vision, natural scenes above and below the horizon differ in the distribution of chromatic and achromatic features. Consequently, many species differentially sample light in the sky and on the ground using an asymmetric retinal arrangement of “blue” and “green” sensitive photoreceptor types. Here we show that in mice this photoreceptor arrangement provides for optimal sampling of natural achromatic contrasts. Two-photon population imaging of light-driven calcium signals in the synaptic terminals of cones expressing a calcium biosensor revealed that “blue”, but not “green” cone-photoreceptors preferred dark over bright stimuli, in agreement with the predominance of dark contrasts in the sky but not on the ground. Therefore, the different cone types do not only form the basis of “colour vision”, but in addition represent distinct contrast-selective channels.

Probing visual receptive fields at single synapse resolution

Katrin Franke, Thomas Euler^{1,2}, Tom Baden^{1,2}

¹Centre for Integrative Neuroscience / Institute for Ophthalmic Research

²Bernstein Centre for Computational Neuroscience (BCCN), all:University of Tübingen, Germany

The retina is a powerful image processor, that sequentially decomposes spatio-temporal photoreceptor activation patterns into increasingly specific parallel channels. As a result, only a small fraction of all available visual information is sent to the brain by retinal ganglion cells. Key to the restriction of retinal neuron response features to highly specific visual patterns are synaptic interactions in the retina's two synaptic layers, the outer and inner plexiform layer (OPL and IPL). Here, individual synaptic connections are subject to powerful modulation by lateral inhibitory interneurons, the horizontal cells in the OPL and the amacrine cells in the IPL. As a result individual synapses may exhibit specific spatio-temporal tunings that differ both pre- and post-synaptically even for neighboring synapses belonging to the same cell, as previously demonstrated in select types of amacrine cells (e.g. Euler et al., 2002; Grimes et al., 2010).

Based on earlier work (Briggman & Euler, 2011), we have developed a technique to sparsely label individual retinal neurons with synthetic calcium indicators in the ex-vivo intact retina, preserving full connectivity. Using two-photon imaging we now probe the visual response properties at the single synapse level both within bipolar cell presynaptic terminals and retinal ganglion cell (RGC) dendrites. This allows to gain detailed insight into how visual signals are processed and integrated within RGCs to ultimately yield the specific response profiles observed at the level of the RGC spike output that is relayed the brain. We study how the spatio-temporal receptive fields of single synapses differ along the length of RGC dendrites, in particular with respect to the impact of dendritic spikes and backpropagating somatic spikes on dendritic integration in different types of RGCs.

Using spatial dense-noise stimuli, our preliminary data confirmed that receptive fields of single synapses can be reliably estimated using our imaging approach both at the level of bipolar cell terminals and RGC dendrites. Consistent with the morphology of the RGC dendritic arbor, synapses and dendritic segments closer to the soma systematically exhibit larger receptive fields. Moreover, different dendritic sectors of the same RGC selectively extract visual information presented in different retinal positions. Conversely, within the spatial resolution of our experimental approach, individual presynaptic terminals belonging to the same bipolar cell exhibit highly overlapping spatial receptive fields, but often differ in their temporal tuning properties.

In conclusion, spatio-temporal receptive fields can be estimated at the single synapse level in the intact retinal network using two-photon calcium imaging. This technique will allow the study of synaptic integration in the inner retina in great detail, yielding to a refined understanding of how complex trigger features observed at the level of the RGC spike train sent to the brain are established through synaptic interactions in the retina's IPL.

Image stabilisation through non-linear retinal processing

Garrett Greene, Erica Ehrhardt³, Tim Gollisch^{2,4}, Thomas Wachtler^{1,2}

¹Department Biologie II, Ludwig-Maximilians-Universität München, Munich

²Bernstein Center for Computational Neuroscience, Munich

³Graduate School of Systemic Neurosciences, Ludwig-Maximilians-Universität München, Munich

⁴Department of Ophthalmology, University Medical Center Göttingen

Fixational eye movements - including drifts, tremors and micro-saccades - shift the visual image across the retina during fixation. These movements can be well above thresholds for visual motion detection, yet in general they produce little or no motion percept. This implies the existence of mechanisms for suppression of motion signals due to eye movements. In the case of directed eye movements, such as saccades and pursuit, the visual cortex is known to receive feedback from motor areas controlling eye movements. It is not clear that such signals exist for fixational eye movements, and indeed, these movements may be too small to be accurately encoded in motor feedback. Hence it has been proposed that these movements should be inferred directly from the retinal signal.

We describe a model in which suppression of eye movement perception can arise as a result of non-linear processing in Parasol-type retinal ganglion cells. These cells implement a non-linear spatial integration, corresponding to individual rectification of bipolar cells within their dendritic field (Hochstein & Shapley, 1976). As a result, they display phase independent responses to motion within their receptive field. Due to their highly transient and phase invariant spiking, these cells seem well adapted to signal motion onset and saccades.

The model uses these cells as input to a motion detection mechanism which can distinguish between local and non-local motion at the retinal level. In this model, motion detection is performed over local regions in the retina. Within each region, non-linear cell activity is summed and thresholded by an inhibitory global motion detecting circuit. Strong simultaneous activation of all or most non-linear cells – which indicates coherent motion of the image within the local region – will result in a threshold crossing, and hence in inhibition of local motion signals from the region. As a result, only in regions of the retina in which the stimulus displays differential motion, will a motion signal be produced.

When tested with a stimulus containing both local differential motion of an object against background, and global shifts of the stimulus which mimic micro-saccades, this model successfully suppresses detection of saccadic movements, while still enabling accurate tracking of object motion. Thus, the model can

account for the inhibition of motion percepts arising from global shifts due to eye movements, even in the absence of any reliable information about eye position.

Acknowledgments: Supported by BMBF grant 01GQ1004A

Modulation of Response Properties in Retinal Ganglion Cells by Remote Stimulation

Vidhyasankar Krishnamoorthy, Tim Gollisch^{1,2}

¹University Medical Center Göttingen, Department of Ophthalmology, Waldweg 33, 37073 Göttingen, Germany,

²Max Planck Institute of Neurobiology, Visual Coding Group, 82152 Martinsried, Germany

Retinal ganglion cells represent the output stage of the retina. The information transmitted by these neurons to the brain is the key for perception of the visual world and thus underlies visually guided behaviour of an animal. Each ganglion cell is primarily sensitive to visual signals in a small area of space, the cell's spatial receptive field. The receptive field region corresponds to the roughly concentric area of few hundred micrometers, over which the cell collects its inputs. For several decades, however, it has been known that the cell's responses to stimuli in its receptive field can be modulated by the visual signals in the far-surround. A rapid shift or motion of the image in the periphery can modify various response characteristics of a ganglion cell, including contrast sensitivity and response dynamics. Here, we revisit these effects of remote stimulation with the aim of exploring quantitative circuit models that can capture the observed phenomena. To this end, we record the spiking activity of ganglion cells in isolated amphibian and mouse retinas with extracellular multielectrode arrays. During the recording, we present various light stimuli to the receptive fields of the cells in the presence or absence of remote stimulation. As remote stimuli we apply moving as well as contrast reversing gratings with different spatial and temporal scales. The response characteristics are then compared to the filtering properties of the neurons as measured with white-noise experiments and reverse-correlation analyses. We show that the remote stimulus both enhances and suppresses the mean firing rate, but only suppresses the evoked activity. Furthermore, we show that the remote stimulus decreases the contrast sensitivity and modifies the response gain. Thus, the ganglion cells encode the stimulus in relation to the whole scene, rather than purely respond to the stimulus in the receptive field. Our results suggest that the global motion signals provide 'spatial context' to the response of the stimulus within the receptive field.

Spatial integration in the receptive field surround of retinal ganglion cells

Daisuke Takeshita, Tim Gollisch^{1,2}

¹University Medical Center Göttingen, Department of Ophthalmology, Waldweg 33, 37073 Göttingen, Germany

²Bernstein Center for Computational Neuroscience Göttingen

How a sensory neuron spatially integrates signals over its receptive field is one of the determinants of the neuron's function. In retinal ganglion cells, for example, it has long been known that signals are linearly integrated in some cells, whereas nonlinear integration occurs in others [1]. Although this difference in spatial integration is thought to give rise to different functional roles in visual processing, a detailed quantification of the integration is still lacking.

Here we aim at quantifying how signals are integrated in the receptive field in the amphibian retina, using closed-loop experiments. Closed-loop measurements allow us to determine the center and surround of the receptive field during the experiment. We then divide the receptive field and present different contrast step stimuli to each subfield. To identify potential nonlinearities in spatial stimulus integration, we perform iso-response measurements, where combinations of different contrasts that lead to the same pre-specified response are determined. A recent study which employed this approach has revealed a threshold-quadratic nonlinearity in the receptive field center [2]. Based on this result, we investigate how signals are integrated in the receptive field surround.

We use multi-electrode arrays to record extracellular spiking activity from isolated amphibian retinas. While the receptive field center is stimulated with a fixed contrast, two distinct surround regions are stimulated with combinations of different contrast values. Iso-response curves are determined for the firing rate and latency. The shapes of these curves reveal the signal integration characteristics in the receptive field surround.

The iso-rate curves revealed two classes of ganglion cells with respect to the surround integration. One class showed a dependence of the nonlinearity on the contrast. For low contrast, the integration was threshold quadratic, while the integration tended to be linear for higher contrast. This cell class showed a threshold-quadratic nonlinearity in the receptive field center. The other cell class showed a threshold-quadratic nonlinearity in the surround, mostly independent of contrast. For these cells, the integration in the center was such a way that the cell was particularly sensitive to spatially homogeneous stimuli [2]. Therefore, it is suggested that retinal ganglion cells have distinct spatial integration properties in the receptive field center and surround.

Acknowledgements

This work was supported by the German Initiative of Excellence, the International Human Frontier Science Program Organization, and the Deutsche Forschungsgemeinschaft (DFG-SFB 889).

References

- [1] Enroth-Cugell C and Robson JG (1966) *Journal of Physiology* 187:517–552.
- [2] Bölinger D and Gollisch T (2012). *Neuron* 73:333-346.

Complement deposition in an experimental autoimmune model of glaucoma in rats

Sabrina Reinehr, Sebastian Becker¹, Sandra Kühn¹, Christina Casola¹, Mathias Kühn¹, Burkhard Dick¹, Stephanie C. Joachim¹

¹Ruhr University Eye Hospital, Experimental Eye Research Institute, In der Schornau 23-25, 44807 Bochum, Germany

Purpose: Little is known about the mechanisms that lead to the loss of retinal ganglions cells (RGC) in glaucoma. In the last years, some studies showed a contribution of the immune system within the RGC loss. Here, we investigate the role of the complement system, as a part of the innate immune system, in a model of experimental autoimmune glaucoma.

Methods: Rats were immunized with optic nerve homogenate (ONA) or S100 in Freund's Adjuvants (FA) and Pertussis toxin (PTx). Animals of the control group (CO) received FA and PTx in sodium chloride. Intraocular measurements were performed before and after the immunization using a TonoLab. After 14 days RGC density was quantified by Brn3a-antibody stained flatmounts. To evaluate the activation of the complement system, cross-sections of the retina were stained with MAC (membrane attack complex). Cell counts of RGC and the complement components were performed using Image J Software.

Results: IOP before and after immunization (ONA: $p=0.9$; S100: $p=0.53$) stayed within the normal range. No change in the density of the RGCs could be observed in the immunized animals of the ONA and S100 group compared to CO after 14 days (ONA: $p= 0.9$; S100: $p= 0.8$). After 28 days a significant RGC loss could be observed ($p<0.05$). MAC staining of the cross-sections showed a significant increase in the ONA group compared to CO ($p= 0.04$). No difference could be detected in the S100 immunized rats ($p= 0.9$).

Conclusion: Our results showed that at 14 days no RGC loss could be observed, but a significant loss can be noted after 28 days. Indeed, a positive MAC staining could be shown in ONA immunized animals. Our findings suggest an activation of the complement system in an early stage of the experimental autoimmune glaucoma. This complement activation could trigger RGC death.

Funding: German Research Foundation (DFG: JO-886/1-1)

Morphology and micro-projection pattern of the cells of origin of the descending Tecto-GLv pathway in the chicken (*Gallus gallus*)

Tomas Vega-Zuniga, Vanessa Marks¹, Stefan Weigel¹, Harald Luksch¹

¹Technische Universität München, Lehrstuhl für Zoologie, Liesel-Beckmann Strasse 4, 85354 Freising, Germany

The optic tectum (TeO), located in the mesencephalon of vertebrates, is a prominent retino-recipient structure retinotopically organized. In birds, it is composed of 15 layers with many varieties of cells. The tectum has afferent and efferent connections with numerous parts of the brain including topographic and non-topographic arrangements. The topographic afferents arise from the retina, the ventral lateral thalamus (VLT), the tectal grey (GT) and the isthmal nuclei (Ipc and SLu); the topographic efferent connections proceed to the isthmal nuclei (Ipc, Imc and SLu), isthmo optic nucleus (ION), nucleus lentiformis mesencephali (LM), the GT and the geniculatus lateralis ventralis (GLv).

Physiological experiments show that micro-stimulation of the TeO generate head movements in the owl. Furthermore, we previously showed that micro-stimulation of the pigeon GLv triggered coordinated eye and head movements in a locus-dependent manner (Vega-Zuniga et al., Soc Neurosci 2011).

Since TeO has a prominent and topographic efferent connection with the GLv (without a significant reciprocal connection) and given that the cells originating this projection are not fully identified, we decided to characterize the morphology and the projection pattern of these cells, including the physiological effects of these neurons into the GLv.

For this purpose, we made a set of experiments in chicken slices containing the TeO-GLv projection including: extracellular tracer-injections in the TeO and GLv, anti-Chat immunohistochemistry and whole-cell / imaging recordings of the GLv while stimulating the layer 8-9 of the TeO.

Radial neurons in the layer 10 of the TeO were retrogradely labeled, showing two dendritic processes: one towards layer 13 and a second one going to the opposite direction towards the superficial tectal layers, ending at three different levels (layer 7, 4 and 2-3) with an incredible high dendritic side-branch density in layer 7. The axon arises from the second dendrite at the level of the layer 8-9, ascending in a "vine-like" fashion until the stratum opticum (SO), where it turns 90 degrees towards GLv.

Micro-stimulation of the layer 8-9 of the TeO showed, in whole-cell recordings, an excitatory postsynaptic response in cells located in the lamina interna (Li) of the GLv. Imaging technique experiments showed a restricted and topographic excitation of the neuropil (Ne) and the lamina interna (Li) of the GLv.

Our results strongly suggest that the "vine-neurons" are the tectal cells projecting topographically to the GLv. Furthermore, the cholinergic immunoreactivity of these neurons correlates with previous work showing cholinergic inputs to the neuropil (Ne) of the GLv.

Spatial Integration of Subunits in Mouse Retinal Ganglion Cells

Michael Weick, Daisuke Takeshita¹, Tim Gollisch¹

¹University Medical Center Göttingen, Ophthalmology; Sensory Processing in the Retina Group; Bernstein Center for Computational Neuroscience Göttingen; DFG-SFB 889

Ganglion cells integrate and process information in the retina and send the output to the brain. For example, they combine input from the center and the surround of their receptive fields. The center of the receptive field can as well be described as an integration of subunits. The subunit character may arise from the anatomical organization of retina and the signal processing of the photoreceptors and interneurons. It has been shown that ganglion cells in salamander deploy different forms of integration of these central subunits. In more detail, two functionally different types of ganglion cells were found, showing subunit nonlinearities that could be described as threshold-quadratic or threshold-square root, respectively. In the present study, we used closed-loop as well as classical open-loop experiments to describe the integration of central subunits of mouse retinal ganglion cells. We found nonlinear integration of nonlinear subunits, similar to what had been described in salamander. In addition, unlike in the salamander retina, we also observed ganglion cells with linear integration. We use pharmacological manipulation to address how these properties arise and discuss functional consequences of the different forms of spatial integration.

Spike-Triggered Analysis of Contrast Adaptation in the Retina

Jian Liu, Tim Gollisch^{1,2}

¹Department of Ophthalmology, University Medical Center Goettingen, Goettingen, Germany

²Bernstein Center for Computational Neuroscience, Goettingen, Germany

Retinal ganglion cells have to encode the visual world under different viewing conditions. When contrast changes, they show a fast dynamical change in sensitivity and temporal filtering characteristics. However, ganglion cells are often better described by multiple filter components in parallel. Here, we therefore ask whether these filter components adapt independently or whether the filters remain fixed, but their relative importance for the ganglion cell response changes. We thus study the temporal features represented in the ganglion cell responses by recording spikes from isolated axolotl retinas using a multielectrode array. We apply spike-triggered average (STA) and spike-triggered covariance (STC) analysis to determine the set of features represented by each ganglion cell under different contrast conditions. Following a switch from a low-contrast condition to one of high contrast, we found for OFF cells that the stimulus feature encoded by the STA under low contrast is preserved as the most significant feature detected by the STC analysis under high contrast. However, a second stimulus feature emerges as an additional filter component under high contrast. For ON-OFF cells with contributions from both ON and OFF pathways, on the other hand, this scheme does not hold. Rather, ON and OFF inputs are found to adapt independently. Further analysis of only those spikes that occurred in the OFF pathway recovered the observation made for pure OFF cells. A simple linear-nonlinear model with additional feedback can account for these filter changes during contrast adaptation. Together, these results suggest that contrast adaptation occurs separately in ON and OFF pathways in the retina and can be described by changing the contributions from multiple parallel filtering processes.

Connexin interactions in the inner retina of the mouse

Arndt Meyer, Birthe Dorgau¹, Sheriar G Hormuzdi², Klaus Willecke³, Reto Weiler¹, Karin Dedek¹

¹University of Oldenburg, Department of Neurobiology, D-26111 Oldenburg, Germany

²University of Dundee, Division of Neuroscience, Dundee DD1 9SY, UK

³University of Bonn, Institute of Genetics, D-53117 Bonn, Germany. This work supported by a Wellcome Trust (WT078791) grant to SGH; a Deutsche Forschungsgemeinschaft (We849/16-1/2) grant to KD and RW; a PhD programme NEUROSENSES stipend to AM.

Electrical coupling via gap junctions is an abundant phenomenon in the mammalian retina and occurs in photoreceptor and horizontal cells, cone bipolar (CB), amacrine (AC) and ganglion cells (GC). Gap junction channels are assembled from different connexin (Cx) subunits, whereby the Cx composition of the channel confers specific properties to the electrical synapse such as permeability, its dynamic modulation, or targeted assembly in cell type-specific circuits. In the inner retina, gap junctions have been shown to couple similar (AC-AC, GC-GC) and dissimilar cell types (AC-CB, AC-GC) within highly specified circuits. In many cases coupling crucially depends on the expression of either Cx36 or Cx45 (Bloomfield & Völgyi, 2009, and therein; Pan et al., 2010). Recently, we demonstrated the expression of a novel connexin, Cx30.2, in a number of ganglion and amacrine cells (Pérez de Sevilla et al., 2010).

In the present study we tried to shed light on the role of Cx30.2 in amacrine cells. Tracer coupling experiments using a Cx30.2-deficient mouse line (Kreuzberg et al., 2005) demonstrated that coupling is not necessarily disrupted in circuits formed by Cx30.2-expressing cells. This suggests that further Cxs are involved in the formation of electrical synapses in those cells. Furthermore, electroretinogram recordings did not reveal any major differences between wildtype and Cx30.2-knockout retinæ. There are two possible explanations for that: 1) other Cx may compensate for the missing Cx30.2, and/or 2) Cx30.2 does not form channels on its own in these cells but instead is integrated into channels made of Cx36 or Cx45. To determine, whether the formation of channels comprising Cx30.2 and either of the other neuronal Cxs is possible, the formation of large intercellular gap junction clusters was investigated in transiently transfected HeLa cells. Our results indicate that interactions with both, Cx36 and Cx45, are possible, but that Cx30.2 cluster formation was especially enhanced when Cx36 was cotransfected.

Those results are consistent with previous findings showing that the deletion of Cx30.2 was largely compensated by Cx36 in other brain areas (Kreuzberg et al., 2008). Consequently, it seems likely that the specific integration of Cx30.2 into subsets of Cx36-containing gap junctions enables cells to discriminate between different synaptic sites in order to specifically modulate the electrical synapses corresponding to distinct circuits. Current experiments therefore focus on the modulation of electrical synapses involving Cx30.2 using various connexin knockout mouse models.

- Bloomfield & Völgyi, 2009, *Nat Rev Neurosci.* 10(7):495-506.
- Pan et al., 2010, *J Comp Neurol.* 518(6):911-27.
- Pérez de Sevilla Müller et al., 2010, *Vis Neurosci.* 27(3-4):91-101.
- Kreuzberg et al., 2005, *Circ Res.* 96(11):1169-77.

- Kreuzberg et al., 2008, Mol Cell Neurosci. 37(1):119-34.

Use of multi electrode arrays for recordings of retinal ganglion cell activity in CACNA1F mutant mouse models

Klaus Schicker, Dagmar Knoflach¹, Eduardo Fernandez², Peter Ahnelt¹, Alexandra Koschak¹

¹Center for Physiology and Pharmacology, Medical University of Vienna. Schwarzspanierstrasse 17, 1090 Vienna, Austria

²Grupo de Investigación NBIO, Universidad Miguel Hernández. Campus de Elche 03202, Elche - Spain

CACNA1F is the gene coding for the L-type Ca²⁺ channel Cav1.4. This channel is almost exclusively expressed in retinal cells and plays a crucial role in the synaptic transmission between photoreceptors and second order neurons. To date more than 50 different mutations in the CACNA1F gene have been described, all of which are leading to a congenital form of night blindness (CSNB2) in humans. It is not completely understood how the different functional channel phenotypes described in heterologous cell systems can all result in defective retinal synaptic transmission underlying CSNB2 symptoms. While many of these mutations have been studied with respect to the perturbation of their biophysical properties none of them have been investigated in their physiological retinal environment. Here we present a functional and histological characterization of retinas from mice harboring either a loss-of-function or a gain-of-function mutation. The latter point mutation has previously been shown in tsA-201 cells to cause a strong leftward shift of the activation curve compared to wildtype (wt) channels. We used a whole-mount retinal preparation on a planar multielectrode array (perforated MEA, Multichannel Systems, Germany) containing 60 independent electrodes allowing us to record from many retinal ganglion cells simultaneously. Retinae were mounted onto the array ganglion cell layer down and were continuously superfused with oxygenated buffer at 37°C and the electrical activity of retinal ganglion cells was recorded. To test for functional changes, retinae of wt and mutant animals were presented with different light stimulation paradigms focused onto the photoreceptor layer using a microscope objective. Immunolabelling of WT and mutant retinal cryosections sections using rod and cone specific markers provided insight into morphological changes in these Cav1.4 mouse models. Ganglion cell activity from isolated whole mount retinas from mutant mice showed significant changes in the response to light stimuli as compared to wt. Most importantly the latency of on-responses to full field light flashes was increased and at the same time contrast sensitivity, as tested by sinusoidal grating stimuli, was vastly diminished. Immunohistochemical stainings of from wt and mutant mouse retinas pointed to a disruption in the organization of the outer plexiform layer where the photoreceptor cells synapse with second order neurons. Taken together our initial experiments indicated that both a loss- and a gain-of-function mutation in Cav1.4 channels resulted in similar morphological and functional retinal phenotypes however additional data are needed to explore and compare the extent of perturbations in mutant compared to wt mice. Financial support was given by the Austrian Science Fund (FWF, P22526 to A.K.) and the Medical University Vienna.

Visual capabilities, visual plasticity and collicular maps in “cortexless” **Esco2**-mutant mice

Evgenia Kalogeraki, Verena Günther¹, Gabriela Whelan², Fred Wolf³, Gregor Eichele², Siegrid Löwel¹

¹Johann-Friedrich-Blumenbach-Institut für Zoologie und Anthropologie and Bernstein Fokus Neurotechnologie, Georg-August-Universität Göttingen, Systems Neuroscience, Germany

²Genes and Behavior Department, Max-Planck-Institute for Biophysical Chemistry, Göttingen, Germany

³Theoretische Neurophysik, Max-Planck-Institut für Dynamik und Selbstorganisation and Bernstein Zentrum, Göttingen, Germany

It was previously shown that deletion of the acetyltransferase *Esco2* in neuroepithelium of mice results in adult animals that lack both the hippocampus and most of the neocortex (Whelan *et al.* 2011). To investigate the role of the neocortex for visual abilities, visual plasticity and retinotopic maps in the superior colliculus of these animals, we subjected *Esco2* mutants and their heterozygous (HZ) littermates to two different behavioural vision tests and also visualized activity maps in their superior colliculus with intrinsic signal optical imaging (Kalatsky and Stryker 2003).

Visual abilities were tested both in a virtual-reality optomotor system and in the visual water task (VWT). Using optomotry, visual acuity and contrast sensitivity of *Esco2* mutants and their HZ littermates were like previously measured in C57Bl/6 mice (Prusky *et al.* 2004, Lehmann & Löwel 2008). After seven days of monocular deprivation (MD) and daily testing in the optomotor setup, HZ mice showed a significant increase of both visual acuity and contrast sensitivity through the open eye while *Esco2* mutants did not improve at all. These data are clear evidence that the visual cortex is necessary for the improvement in the visual abilities through the open eye after MD (Prusky *et al.* 2006). In contrast, we observed significant differences in the VWT: while HZ mice had a visual acuity of 0.6 cyc/deg, like C57Bl/6 mice, between *Esco2* mutants were not at all able to learn the task and therefore could not be tested in this visual discrimination paradigm.

Finally, we imaged activity maps in the superior colliculus of *Esco2* mutants. C57Bl/6 mice possess highly ordered retinotopic maps in their superior colliculus (e.g. Cang *et al.* 2008) and it is generally assumed that the development of these maps depends on a combination of molecular guidance cues recognized by retinal afferents and their patterned neuronal activity. Thus the *Esco2* mutants provide a unique opportunity to assess the role of the neocortex for the orderly representation of the visual world in the superior colliculus.

We measured activity in the right superior colliculus in a depth of 1000 μm below the surface through the intact skull. To be able to compare the data with previously published maps, the stimulus monitor was positioned in the visual field contralateral to the imaged superior colliculus and displayed moving bars along the dorsoventral or nasotemporal axis to stimulate constant lines of both elevation and azimuth (Cang *et al.* 2008). We detected activity maps in the superior colliculus of all *Esco2* mutant mice but interestingly in most of the mice, there were no or only rudimentary retinotopic maps.

These data indicate that the neocortex has a greater role for retinotopic maps in the superior colliculus than had previously been assumed. Whether neocortex is necessary for initial map formation or for maintenance is presently being investigated. In addition, our data support the notion that sensory learning after MD in mice depends on the visual cortex.

Supported by the BMBF 1GQ0921 and 1GQ0810

Classifying retinal ganglion cells using responses to naturalistic stimuli

Fernando Rozenblit, Tim Gollisch^{1,2}

¹University Medical Center Göttingen, Dept. of Ophthalmology, Waldweg 33, 37073 Göttingen, Germany

²Bernstein Center for Computational Neuroscience Göttingen, 37073 Göttingen, Germany

Retinal ganglion cells (RGCs) form the output layer of a complex neural network of bipolar, amacrine and horizontal cells. Many types of RGCs can be morphologically identified. For e.g., the primate retina contains at least 17 different classes of RGCs. It has been postulated that each type encodes distinct features of the visual field, thus displaying stereotypical functional responses when relevant stimuli are presented. The most frequently used characteristics are their responses to steps in light intensity, direction selectivity, receptive field size and dynamics. For the receptive field properties, a common technique is to present pixels whose intensities are drawn independently from a binary or Gaussian distribution. Reverse correlation (spike-triggered average, STA) is then used to obtain the spatial and temporal components of the receptive field.

However, natural stimuli are both spatially and temporally correlated, with power spectra shown to follow a power law, and one may expect that responses to correlated and uncorrelated stimuli differ. Correlated stimuli have already been shown to be more efficient in driving RGCs, evoking higher firing rates.

Using a stochastic process, we generate a naturalistic stimulus correlated both in space and time, with similar statistical and spectral properties as natural images (pink noise). For our experiments, we record spikes from an isolated salamander retina with multi-electrode array (252 electrodes) under visual stimulation. To recover the spatio-temporal receptive fields of the recorded cells, the STA is appropriately corrected for the correlations contained in the stimulus. Cells are grouped according to their properties using the spectral clustering algorithm.

As expected, cells show a higher firing rate for the correlated stimulus. Surprisingly, some of the detected cells do barely respond to spatio-temporal white noise stimulation, if at all, but can be well analyzed with our pink noise stimulus. We further discuss properties of the identified cell clusters and how they relate to previously described functional characteristics.

Functional properties of spontaneous synaptic events in horizontal cells of the mouse retina

Andreas Feigenspan

¹FAU Erlangen-Nürnberg, Lehrstuhl für Tierphysiologie, Staudtstraße 5, 91058 Erlangen, Germany

Horizontal cells are interneurons at the first synapse of the visual system that are thought to provide negative feedback to photoreceptors and contribute to the center-surround organization underlying the receptive field properties of many retinal neurons. In vertebrates, horizontal cells receive major synaptic input from photoreceptors, which release glutamate at highly specified ribbon synapses. The mouse retina contains only axon bearing horizontal cells with dendrites contacted exclusively by cones and an elaborate axon terminal system postsynaptic to rods. Soma and axon terminal system are connected by a long and thin axon which is likely to electrically isolate the two compartments.

I have used vertical and horizontal sections of the mouse retina to investigate the functional properties of ionotropic glutamate receptors expressed on horizontal cell somata. Spontaneous EPSCs (spEPSCs) were recorded in the whole-cell mode of the patch-clamp technique from visually identified cell bodies in transgenic mice, in which expression of eGFP was driven by the promoter for the glutamate decarboxylase-67 isoform.

Glutamatergic spEPSCs displayed an average amplitude of -24 pA (range: -10 to -52 pA) when recorded at -60 mV holding potential. The kinetics of the spEPSCs was fast with a mean 10–90 % rise time of about 350 μ s. The decay kinetics followed a single exponential function with a time constant $\tau \sim 850 \mu$ s. In addition, larger and about 100-fold slower inward currents were occasionally observed, which gave rise to long lasting depolarizations (mean values: 10–90 % rise time: 43 ms; half-width: 86 ms) when recorded in current-clamp (Fig. 1 A, B). These depolarizations displayed rather invariant amplitudes with a mean value of 75 mV.

To investigate the functional expression of ionotropic glutamate receptors, blockers of AMPA and kainate receptors were applied extracellularly. The non-NMDA receptor blocker CNQX abolished nearly all spEPSCs but had no effect on slow inward currents. In addition, CNQX induced a small outward current or hyperpolarization (Fig. 1 C). Likewise, the selective AMPA receptor antagonist GYKI 52466 largely reduced spEPSCs, and it also induced a small outward current (Fig. 1 D). Since this outward current was observed regardless of the applied compound, it most likely reflects the application-induced clearance of tonically released glutamate from perisynaptic space. Cyclothiazide, which reduces agonist-evoked desensitization of AMPA receptors, increased the decay time constant of spEPSCs to > 4 ms. The kainate receptor-selective blocker SYM 2081, however, was much less effective in blocking fast spEPSCs. These results indicate that spEPSCs of horizontal cell bodies are mediated mostly by AMPA receptors. Finally, the competitive antagonist of GABA_A receptors bicuculline had no effect on spontaneous activity, suggesting that GABA is not synaptically released on horizontal cells.

In summary, a slice preparation has been established to study horizontal cell function in a semi-intact retinal network. The results presented here verify the predominance of glutamatergic neurotransmission for horizontal cell function, and they provide insight into the biophysical properties of ionotropic glutamate receptors expressed postsynaptically to the ribbon synapse in the vertebrate retina.

A



B

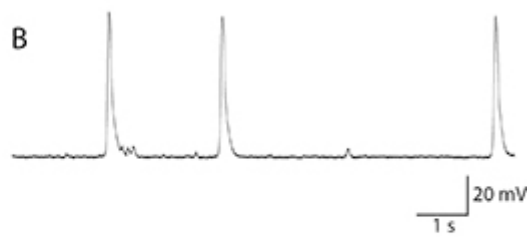

C

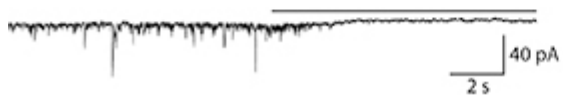

D

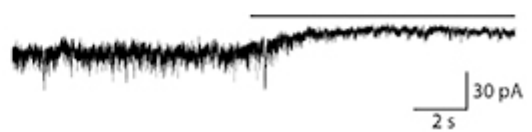

Rhythmic ganglion cell activity in bleached or blind mouse retinae

Henrike Stutzki, Jacob Menzler², Günther Zeck¹

¹Neurochip Research Group, NMI at the University Tübingen, Germany;

²Helmholtz Zentrum, München, Germany

Animal models of the human disease Retinitis pigmentosa can not only help to understand the pathophysiology behind this disease, but also provide insight into the complex circuitry of the retina in general. The loss of photoreceptors deprives the retina from excitatory input, the so-called dark current. This may lead to an imbalance between excitation and inhibition and subsequently to an altered neuronal output of the system.

In rodent models of Retinitis pigmentosa the retinal ganglion cells show oscillatory electrical activity. However, it remained unclear if the observed rhythmic ganglion cell activity is attributed to alterations occurring during rod degeneration or if rhythmic activity is an intrinsic property of healthy retinal circuitry which is masked by the photoreceptor's dark current.

To address this question we recorded and analysed the electrical activity of the retinal ganglion cells in healthy and blind mouse retinas using high-density multi-transistor arrays. The electrical imaging of individual retinal ganglion cells using high-density multi-transistor arrays composed of 16,384 sensors (on 1mm²) has been reported recently (Menzler and Zeck 2011).

Here we found that the fundamental spike frequency in healthy, bleached C57Bl6 retinas is in the same range as the spike frequency in blind *rd10* retinas. In both retinas rhythmic ganglion cell activity (5 - 7 Hz) was recorded. Inhibition of glutamatergic receptors or inhibition of gap junctional coupling abolished rhythmic ganglion cell spiking, indicating that it is driven by presynaptic circuitry. Our results suggest that bleaching of the photoreceptors in healthy retinas leads to a similar neuronal retinal output as observed in the *rd10* retina. Therefore we hypothesize that the dark current of the mature photoreceptors masks the inherent oscillatory activity of the downstream retinal circuits.

Menzler, J. and G. Zeck (2011). "Network Oscillations in Rod-Degenerated Mouse Retinas." *J. Neurosci.* 31(6): 2280 –2291.

Supported by the German Federal Ministry of Education and Research (BMBF grant 0312038)

Spatial Contrast Adaptation in Mouse Retina

Mohammad Hossein Khani, Vidhyasankar Krishnamoorthy^{1,2}, Tim Gollisch^{1,2}

¹Department of Ophthalmology, University Medical Center Göttingen, Waldweg 33, 37073 Göttingen, Germany

²Bernstein Center for Computational Neuroscience Göttingen, 37073 Göttingen, Germany

³International Max Planck Research School for Neuroscience, Göttingen, Germany

The retina of the eye is the point of entry for visual stimuli into an animal's nervous system. The specific structure of the retina plays an important role in categorizing and filtering the huge amount of information that impinges on the eye. Like in other sensory systems, the neural circuit within the retina has the task of providing an ongoing representation of the external world. It has to transmit the necessary information to the brain for processing visual stimuli despite changes in the environment. In order to achieve this goal, the neuronal network of the retina adjusts its sensitivity according to the prevailing stimulus characteristics. These adaptation mechanisms enable the retina to cope with changing visual contrast. This contrast adaptation process is generated through synaptic interactions between bipolar cells and ganglion cells along with inherent cellular mechanisms of ganglion cells. In this study, we investigated the spatial structure of contrast adaptation in mouse retina ganglion cells. By measuring spike responses in isolated retinas with multi-electrode arrays under visual stimulation and analyzing the data with linear-nonlinear cascade models, we measured the effect of changes in contrast at different spatial location on the sensitivity and the filtering characteristics of the cells. This allows us to determine whether contrast adaptation occurs locally within subfields of a ganglion cell's receptive field or whether it is a global property of the receptive field in its entirety.

Retinal topography and central visual projections of a palaeognath bird, the Chilean Tinamou (*Nothoprocta perdicaria*)

Quirin Krabichler, Harald Luksch¹, Tomas Vega-Zuniga¹, Gonzalo J. Marín^{2,3}, Cristian Morales², Jorge Mpodozis²

¹Technische Universität München, Lehrstuhl für Zoologie, Freising-Weihenstephan, Germany

²Universidad de Chile, Facultad de Ciencias, Santiago, Chile

³Universidad Finis Terrae, Facultad de Medicina, Santiago, Chile

The Tinamous (Tinamidae) are a bird family comprising 47 species, which forms a monophyletic group with the flightless 'Ratites' (Ostrich, Rhea, Kiwi, Emu and Cassowary), together establishing the avian line of the Palaeognathae. They diverged from the Neognathae (all other extant birds) very early in the evolution of birds, more than 100 Mya. Because of their long history of divergent evolution, and because Tinamous are the only living Palaeognaths who retained their ability to fly, it is of interest to compare their central nervous system with the ones of well-researched Neognath models, such as chick and pigeon.

In this study, we have focused on the visual system of the Chilean Tinamou, using retinal wholemounts to look into the retinal ganglion cell (RGC) layer topography and intraocular injections of cholera toxin subunit B (CTB) to study the retinofugal projections to central targets.

The Chilean Tinamou has a well-developed visual streak with two areas of surprisingly high RGC density: a centrally located area centralis (Peak 59.000 cells/mm²) and a dorso-temporal region (peak 39.000 cells/mm²). The overall RGC layer count per retina was estimated to exceed 4.000.000, which puts *Nothoprocta perdicaria* among the birds with the highest number of those cells, indicating the great importance of the visual system for this animal.

Retinal projections to the midbrain and thalamus were confined to the contralateral side and led to all known retinorecipient regions described in Neognathae, including the layers 2 – 7 of the optic tectum (TeO), the nuclei of the lateral geniculate complex (GLv and the GLd-complex), the intergeniculate leaflet (IGL), a prominent lateral anterior nucleus (LA), the pretectal nuclei tectal grey (GT) and nucleus lentiformis mesencephali (LM), and the nucleus of the basal optic root (nBOR). In addition, retrogradely labelled neurons were found in the nucleus isthmo-opticus (ION) and nucleus of Evinger-Westphal (EW). The TeO is well developed and has the general avian pattern of distinct layers, although some of them show conspicuous differences in their relative sizes as compared to the tectum of chicken or pigeons. The neuroanatomical analysis of higher processing levels of the visual system has shown them to be equally well established, including an attentional isthmo-tectal loop comprising layer 10 shepherd-crook neurons and Ipc paintbrushes in the TeO. The Ipc paintbrushes densely ramify in tectal layers 5 and 9, suggesting a strong relation with the Type I and Type II tectal ganglion cells (TGC), as the dendritic terminals of these tectal output neurons distribute in those layers.

Our results indicate that the palaeognathous Chilean Tinamou is a highly visual bird, as evidenced by the

high spatial resolving power and the well-developed central visual projections. Furthermore, the Tinamou's visual system reflects an evolutionarily conserved avian pattern showing only minor differences on a macroscopic level as compared to neognathous birds such as chick and pigeon.

How retinal ganglion cells encode object motion and motion direction

Norma Kühn, Tim Gollisch^{1,2}

¹University Medical Center Göttingen, Dept. of Ophthalmology, Waldweg 33, 37073 Göttingen, Germany

²Bernstein Center for Computational Neuroscience Göttingen, Germany

In our everyday life we can distinguish moving objects in a scene. What we usually do not perceive is the motion of our eyes. This motion shifts the image on the retina even while fixating an object and influences the encoding of that image. Therefore mechanisms must exist which decorrelate eye movements and image information from the shifted scene.

An important step for understanding these mechanisms is to analyze different encoding strategies at the level of the retina. Here we study what information about eye movements and moving objects can be extracted from the responses of specialized retinal ganglion cells and populations of cells.

It is already known that some retinal ganglion cells respond preferentially to certain directions of motion. Furthermore, a new functional property has been observed where cells respond to the motion of an object on a moving background, but not when the whole visual field moves homogeneously¹. These object-motion-sensitive (OMS) cells are considered to play a crucial part in the decorrelation of eye movements and object motion. A significant number of the OMS cells we found even display a direction preference, indicating that OMS cells are not a homogeneous group.

Furthermore, it has been shown that also the order of firing of neighboring RGCs can encode the direction or the orientation of a moving stimulus². Here we study the interplay between these different aspects of motion encoding in the retina.

We project visual stimuli onto isolated salamander retina and record the responses of retinal ganglion cells using a multi-electrode array. We apply a set of drifting and jittering images to investigate different features of motion.

Using reverse correlation analysis and information theory, we are able to extract which motion feature is driving each cell and how much information can be gained from single-cell and population responses by downstream brain regions.

1. B. P. Olveczky, S. Baccus, and M. Meister, "Segregation of object and background motion in the retina", *Nature* 423:401–8, 2003.
2. G. B. Stanley, J. Jin, Y. Wang, G. Desbordes, Q. Wang, M. J. Black, and J.-M. Alonso, "Visual Orientation and Directional Selectivity through Thalamic Synchrony", *J Neurosci* 32: 9073–88, 2012.

A New Psychophysiological Model of Absolute Visual Thresholds in Man

Werner Georg Karl Backhaus

¹Freie Universität Berlin and Technische Universität Berlin, AG Psychophysiology, Flachbau HFT-CO, Einsteinufer 25, 10587 Berlin, Germany

A new psychophysiological model is presented (see Fig. 1), describing absolute visual thresholds in man in respect to monochromatic light. This model extends the model of neuronal color coding and spatial color sensations (NCC-SCS, Backhaus, 1998, 2008) from the photopic light intensity range (day vision, color vision), via the mesopic (dawn vision) to the scotopic (night vision, achromatic vision) intensity ranges.

Results: The model of absolute visual thresholds of the dark adapted (= 30 min.) eye, describes 1) the photon statistics of different light sources, 2) the phototransduction process in rods, 3) the respective neuronal coding system, steering 4) the elementary color (EC) sensations black (bk) and white (w) of different amounts, seen as different bright grays. 5) Potential fluctuations in the neuron network are taken into account. 6) A stochastic model describes Y/N judgments of light discrimination, according to Thurstone's Law of Comparative Judgment. Because of the huge numbers of ions moving in the interconnected neurons, the fluctuations of the steered sensations are best described by Gaussian distributions, in agreement with the central limit theorem. In addition, 7) magnitude estimation and the respective decision making processes are included. 8) The model realizes that every photon, absorbed by a rhodopsin molecule, and any spontaneous decay of rhodopsin, causes a small excitation of short duration (bump). At very low photon rates, the bumps only intersperse. 9) Above the stochastic threshold, the bump potentials sum up per time-slice. In this case, the membrane potential follows the phototransduction function with increasing intensity. 10) The visual neurons of the last stage steer the amounts of the elementary color sensations black (bk) and white (w) in the respective spatial elemental spots, which look darker or brighter gray to the observer. The specific brightness values $B(bk) = 0$ and $B(w) = 1$ average to total brightness (B). 11) Since individual photons are usually not seen, the model possesses respective sensational and detection thresholds. 12) Subjective measures of related judgments of light are included. 13) Psychophysical experiments have been simulated with the model, determining the parameters for best fits of the predicted data to measured average-data from the literature, in a first approach. 14) The model will be further gauged to psychophysical data of individual observers, measured with our computerized psychophysical multipurpose-setup (see Krensel & Backhaus, this volume).

Acknowledgements This research is part of the fundamental research project "Measurement and Simulation of Photopic and Mesopic Vision," funded by the German Federal Ministry of Education and Research (BMBF-13N10915).

References

Backhaus, W.G.K., 1998. Physiological and psychophysical simulations of color vision in humans and animals. In: *Color Vision - Perspectives from Different Disciplines*, eds. W.G.K. Backhaus, R. Kliegl & J.S. Werner, pp. 45-77. De Gruyter, Berlin.

Backhaus, W.G.K., 2008. Psychophysiological simulations of spatial color vision: II. light and color sensations. In: *Sechstes Symposium Licht und Gesundheit*, 13.-14.3.2008. Eine Sondertagung der TU

Krensel, A. & Backhaus, W.G.K., this volume. Psychophysical measurements of absolute visual thresholds in man.

Psychophysiological Model of Absolute Visual Thresholds in Man

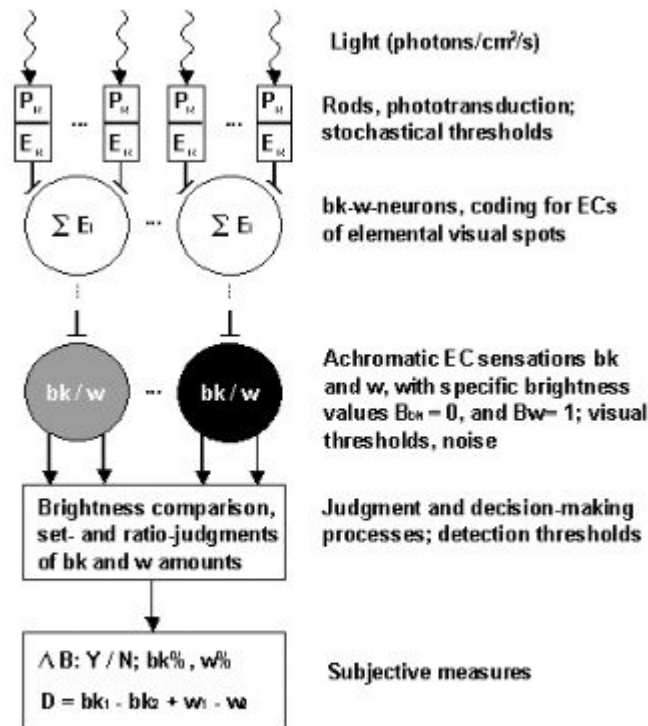

Fig. 1 Scheme of the model of absolute visual thresholds in man. P: photon rate, effectively absorbed in a rod; E: sel. membrane potentials of rods and neurons; B: brightness difference; %: amounts of elementary colors (ECs) black (bk) and white (w); D: set-difference of the ECs black and white. (See text).

Structure-function relationship of direction-selective cell types in the optic tectum of larval zebrafish

Johann H Bollmann, Chintan A Trivedi¹, Fabian Svava¹, Colette M Maurer², Soojin Ryu², Jens P Gabriel¹

¹Max Planck Institute for Medical Research, Biomedical Optics - Neural Circuits and Behavior, Jahnstrasse 29, 69120 Heidelberg, Germany

²Max Planck Institute for Medical Research, Developmental Genetics of the Nervous System, Jahnstrasse 29, 69120 Heidelberg, Germany

Elucidating the neural mechanisms underlying visually guided motor behaviors has long been a rewarding task in the analysis of nervous systems, from which general principles of information processing in the brain have been derived. The experimental accessibility of the zebrafish CNS holds the promise that mechanisms thought to be implemented in the vertebrate visuo-motor pathway can be studied in greater detail. Here we present new results describing aspects of the visuo-motor transformation during prey capture behavior at the behavioral and functional level.

First, we have developed a closed-loop visual stimulus system in order to elicit fictive prey capture sequences in minimally restrained larval zebrafish (C. Trivedi et al, SfN-abstract 2011), Using a high-speed camera, we recorded eye and tail movements and provide a quantitative description of the motor patterns executed during this goal-directed behavior. Motor sequences evoked by a finely tuned set of visual stimuli closely resembled those during prey capture performed by freely moving larvae. By controlling the virtual prey object on a rapid time scale, we were able to explore the efficacy and temporal constraints of the visuo-motor transformation underlying this behavior.

Second, at the functional level, we use two-photon Ca²⁺ imaging to identify neuronal populations likely involved in the processing of moving targets in the optic tectum, and study their morphological and functional properties by two-photon targeted patch-clamp recordings of identified neurons (J. Gabriel et al, SfN-abstract 2011). The tectum is a layered network, built of several, morphologically distinct cell-classes. By using novel transgenic lines expressing genetically encoded Ca²⁺ indicators in subsets of tectal neurons, we provide evidence that functional properties, such as directional tuning, strongly correlate with cellular morphology and the laminar organization of specific cell classes in the tectum. The arbors of differently tuned cell types showed stereotypic differences in shape and laminar profile within the tectal neuropil. Using whole-cell voltage-clamp recordings, we observed that excitatory synaptic inputs were directionally tuned and matched the preferred direction of spike output in these cell types, while inhibitory inputs were selective for non-preferred directions. Functional Ca²⁺ imaging in afferent axons showed a matching laminar distribution of direction-selective, presynaptic activity. These results suggest that direction selectivity in these cell types is strongly determined by tuning of excitatory inputs from direction-selective retinal ganglion cells. In summary, different directions are represented in different layers, which suggests a simple mechanism how tectal neurons acquire directional tuning in a developing visual circuit.

Support: Max-Planck-Society, Deutsche Forschungsgemeinschaft

Ganglion cell mosaics and their potential influence on orientation preference maps

Manuel Schottdorf, Wolfgang Keil^{1,3}, Fred Wolf^{1,3}

¹Max Planck Institute for Dynamics and Self-Organization, D-37077 Göttingen, Germany

²Institute for Theoretical Physics 3, University of Würzburg, D-97074 Würzburg, Germany

³Bernstein Center for Computational Neuroscience, University of Göttingen, D-37077 Göttingen, Germany

We analyze the properties of Orientation Preference Maps (OPMs) created by hexagonal Retinal Ganglion Cell (RGC) mosaics in the linear feed-forward approximation. After analytically calculating a cortical cell's receptive field and its power spectrum, we extract optimal orientation and optimal spatial frequency of a grating stimulus from it. We will compare the distribution of optimal spatial frequencies with experimental data. Following the description of a single cell's properties, we advance to an analytic description of the OPM, its spectrum and the pinwheel density. Finally we confirm the findings numerically and include a quantitative description of the effects of positional noise on the RGC mosaic.

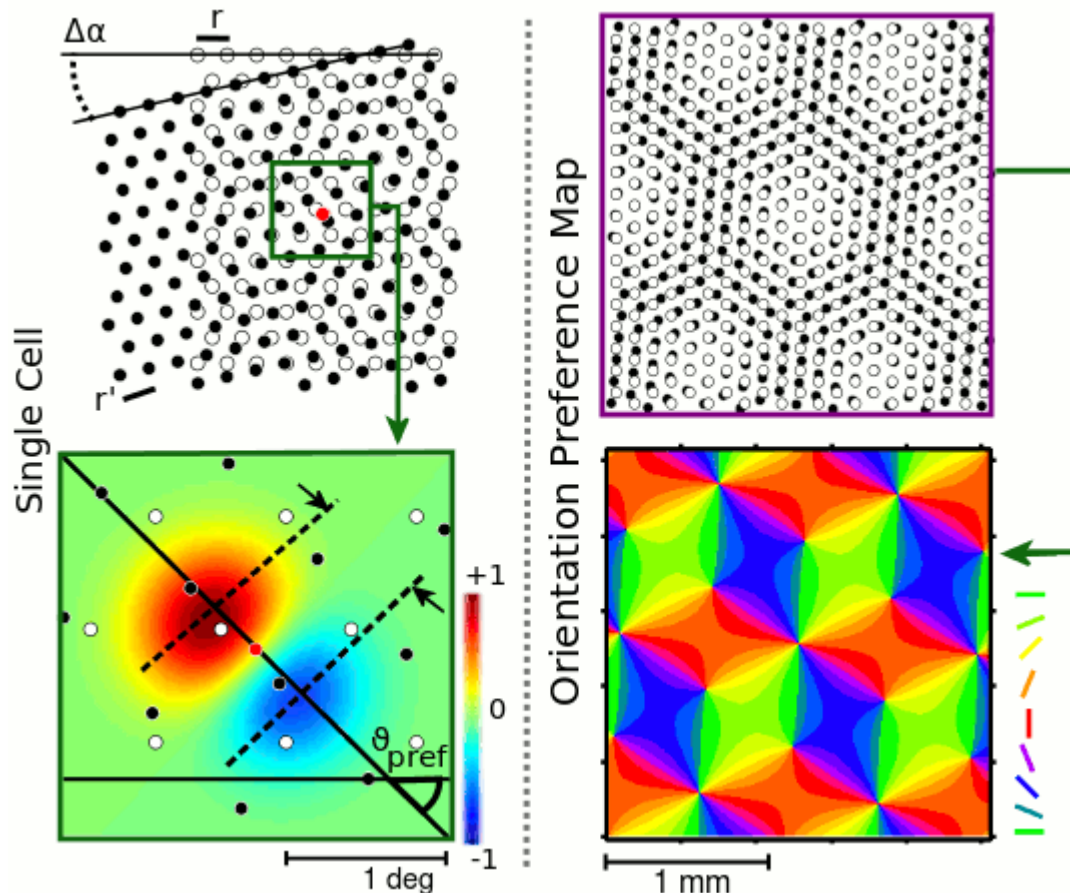

Early multisensory interaction revealed through simultaneous inter-areal recordings in the ferret midbrain

Iain Maurice Stitt, Edgar Galindo-Leon¹, Florian Pieper¹, Gerhard Engler¹, Andreas K. Engel¹

¹University Medical Center Hamburg-Eppendorf, Dept. of Neurophysiology and Pathophysiology, Martinistr. 52, 20246 Hamburg, Germany

The mammalian superior (SC) and inferior colliculi (IC) are highly conserved midbrain structures that are located very early along the visual and auditory processing pathways respectively. In addition, the SC represents one of the earliest nodes where inputs from different sensory modalities converge. The juxtaposition of spatially aligned visual, auditory, somatosensory and pre-motor layers facilitate the rapid integration of multisensory inputs and generation of orienting movements. The SC receives auditory afferent input from the IC. Although traditionally thought to be a strictly unisensory structure, previous studies in the barn owl have shown that the external nucleus of the IC responds to visual stimulation under certain circumstances. Visual responses in the barn owl IC are speculated to be the product of SC feedback inputs that act to maintain the alignment of auditory and visual spatial maps between the structures. Since previous studies have primarily been performed on barn owls, the multisensory interplay between these two midbrain structures remains poorly understood in mammals.

We recorded multi neuron activity and local field potentials (LFP) from the SC and IC simultaneously with silicon multichannel probes in the anaesthetised ferret. Visual stimuli, which consisted mainly of flashes, drifting gratings and coherent motion dots were presented on a monitor placed 28.5cm in front of the animal. Auditory stimuli consisted of clicks and wide-band noise presented through a speaker placed approximately 12cm from the contralateral ear. To assess both unisensory and multisensory response properties, visual and auditory stimuli were presented alone and simultaneously. In response to auditory clicks, robust ERPs and spike responses were observed in the IC. Similarly, large ERP and spiking responses were observed for flash stimuli in all SC layers and click stimuli in intermediate and deep layers. While visual stimulation did not evoke spiking responses in the IC, responses were generally characterised by small amplitude ERPs, which generally displayed little or no power increase in any frequency range. Instead, flash-evoked ERPs in the IC were defined by band-limited increases in inter-trial coherence in the beta (16-25 Hz) and gamma (30-60 Hz) frequency ranges. This suggests flash stimuli produce a phase-reset of ongoing oscillations on the IC. Further analysis will focus on the interaction between SC and IC, with focus on determining the source of visual evoked IC responses.

Poster Topic

T16: Vision: Striate and Extrastriate Cortex, Eye Movement and Visuomotor Processing

- T16-1A** The Effect of Language on Horizontal Asymmetry in Overt Attention
Zaeinab Afsari, Jose P Ossandon, Matti Krüger, Matthias Hampel, Peter König
- T16-2A** Influence of a cortical lesion in the motor cortex on visual cortex plasticity in adult mice.
Justyna Pielecka-Fortuna, Evgenia Kalogeraki, Siegrid Löwel
- T16-3A** Reelin-deficient mice possess normal visual acuity and visual cortical maps
Ann-Kristin Martens, Bianka Goetze, Karl-Friedrich Schmidt, Robin Wagener, Jochen Staiger, Siegrid Löwel
- T16-4A** Perisaccadic response modulations in area V4 of the macaque monkey
Steffen Klingenhoefer, Markus Wittenberg, Thomas Wachtler, Frank Bremmer
- T16-5A** Retracted
- T16-6A** A computational model of light scatter and image formation in the human eye
Ismael Kelly Pérez, Annette Werner
- T16-7A** Dark exposure rescues ocular dominance plasticity in the visual cortex of adult mice in an age-dependent manner
Sophia Katharina Stodieck, Bianka Goetze, Franziska Greifzu, Hugo Cruces-Solis, Karl-Friedrich Schmidt, Siegrid Löwel
- T16-8A** Effects of locomotion on response properties and functional connectivity in mouse primary visual cortex
Sinem Eriskan, Agne Vaiceliunaite, Florian Franzen, Alexandra Wal, Steffen Katzner, Laura Busse
- T16-1B** Human and non-human primate homologues of stereomotion in cortex
Sylvia van Stijn, Ralf Deichman, Wolf Singer, Hwan Sean Lee
- T16-2B** Discrepant reach goal representations in local field potentials and spiking activity in parietal reach region
Alexander Gail, Christian Klaes, Stephanie Westendorff
- T16-3B** Effects of interhemispheric connections on the contrast response function in cat primary visual cortex
Thomas Wunderle, David Eriksson, Christiane Peiker, Kerstin E. Schmidt

- T16-4B** Reversals of illusory depth or illusory rotation in structure-from-motion: an MEG study
Alexander Pastukhov, Mandy Bartsch, Solveiga Stonkute, Jens Max Hopf, Jochen Braun
- T16-5B** Stimulus representations in body-selective regions of the macaque and human cortex assessed with event-related fMRI
Jan Jastorff, Ivo D. Popivanov, Natalie Caspari, Guy A. Orban, Wim Vanduffel, Rufin Vogels
- T16-6B** Different extraocular motoneuronal subgroups control fast and slow phase components of the optokinetic reflex in *Xenopus laevis*
Johanna Miriam Schuller, Alexander Georg Knorr, Stefan Glasauer, Hans Straka
- T16-7B** Social experience modulates adult ocular dominance plasticity in mice
Konrad Lehmann, Jenny Balog
- T16-8B** Influence of Intermittent Theta-Burst TMS on Rat Visual Performance and Neuronal Activity Marker Expression when Applied during the Critical Cortical Period
Diana Veronica Castillo-Padilla, Klaus Funke
- T16-9B** Combining wearable eye-tracking with 4p light-field measurements: towards controlling all bottom-up and top-down factors driving overt attention during real-world tasks
Josef Stoll, Mandana Sarey Khanie, Sandra Mende, Marius t Hart, Marilynne Andersen, Wolfgang Einhäuser
- T16-1C** Population tuning and attentional modulation of human BOLD responses to spiral motion patterns
Sepideh Fazeli, Carsten Schmidt-Samoa, Peter Dechent, Stefan Treue
- T16-2C** Visual cortical development and ocular dominance plasticity in the absence of NKCC1
Katja Krempler, Knut Kirmse, Christian A. Hübner, Otto W. Witte, Knut Holthoff
- T16-3C** Pairing-induced plasticity in the orientation preference map depends on the context of the local neural circuitry in ferret visual cortex
David Edward Whitney, Santosh Chandrasekaran, Juan Daniel Florez Weidinger, Seong-gi Kim, Fred Wolf, Justin Crowley
- T16-4C** Is there a critical area size for the transition from interspersed to columnar V1 architecture?
Wolfgang Keil, Fred Wolf, Matthias Kaschube, Michael Schnabel, David M. Coppola, Siegrid Loewel, Len E. White
- T16-5C** Self-organisation of finite bandwidth orientation preference maps
Conor Dempsey, Wolfgang Keil, Dominik Heide, Fred Wolf
- T16-6C** Early visual processes involved in Vernier misperception under orientation masking : contributions of center-surround and spatial frequencies
Tzvetomir Tzvetanov
- T16-7C** Systematic deviation of eye-movement direction from stimulus-direction during Optokinetic Nystagmus

- T16-8C** PSD-95 lacking synapses in the visual cortex retain a high degree of AMPA receptor silence
Xiaojie Huang, Karl-Friedrich Schmidt, Bianka Goetze, Löwel Siegrid, Oliver Schlüter
- T16-9C** PSD-95 KO mice retain a juvenile ocular dominance plasticity into late adulthood
Bianka Goetze, Karl-Friedrich Schmidt, Xiaojie Huang, Oliver M. Schlüter, Siegrid Löwel
- T16-10C** *In vivo* identification of GABAergic and glutamatergic neurons at early developmental stage in mouse visual cortex
Michael Kummer, Knut Kirmse, Otto W. Witte, Knut Holthoff
- T16-1D** Single spine synaptic inputs in mouse visual cortex *in vivo*
Diana Deca, Nathalie Rochefort, Arthur Konnerth
- T16-2D** Cortical plasticity in the face of congenitally altered input into V1
Jane Klemen, Michael B. Hoffmann, Christopher D. Chambers
- T16-3D** Cortical plasticity in the human visual cortex - Effect of chiasma opticum abnormalities on ventral visual areas
Falko R Kaule, Barbara Wolynski, Anil Kumar, Irene Gottlob, Jörg Stadler, Oliver Speck, Martin Kanowski, Synke Meltendorf, Michael B Hoffmann
- T16-4D** Ultra-high spatial resolution fMRI of the human visual cortex at 7 Tesla magnetic field strength
Juan Lei, Renat Yakupov, Falko R. Kaule, Frank Godenschweger, Oliver Speck, Michael B. Hoffmann
- T16-5D** Neuronal nonlinearity explains differences in visual spatial resolution between darks and lights
Jens Kremkow, Jianzhong Jin, Stanley Jose Komban, Yushi Wang, Reza Lashgari, Michael Jansen, Xiaobing Li, Jose-Manuel Alonso
- T16-6D** Zebrafish *bel* mutant as a model for infantile nystagmus syndrome (INS): Pharmacologic interactions with the ocular motor system
Maresa Afthinos, Ying-Yu Huang, Dominik Straumann
- T16-7D** Top-down attention modulates post-saccadic remapping in macaque MT
Tao Yao, Stefan Treue, Suresh KRISHNA
- T16-8D** Brightness and color discrimination in the Mongolian gerbil
Kay Thurley, Josephine Henke, Christian Garbers, Christian Leibold, Thomas Wachtler
- T16-9D** Visualization of transcranial magnetic stimulation effects by voltage-sensitive dye imaging
Vladislav Kozyrev, Ulf T. Eysel, Dirk Jancke

The Effect of Language on Horizontal Asymmetry in Overt Attention

Zaeinab Afsari, Jose P Ossandon¹, Matti Krüger¹, Matthias Hampel¹, Peter König^{1,2}

¹Institute of Cognitive Science, University of Osnabrück

²Institute of Systems Neuroscience, University Medical Center, Hamburg Eppendorf

Attentional asymmetry was first reported on hemineglect patients. Subsequent studies demonstrated a lateral asymmetry in healthy subjects as well. Here, we explore the influence of language and direction of writing on the phenomenon of attentional asymmetry. Subjects were reading text primes and subsequently freely viewed natural scenes while eye movements were recorded. Primes involved texts written in native or secondary language using right-to-left (RTL), left-to-right (LTR), or mirrored left-to-right (mLTR) writings. Target images comprised natural, urban and fractal pictures. Experiment 1 investigates the effect of reading direction in bilingual participants with either RTL (native) or LTR (secondary) texts primes. In the first second after onset of the target images, subjects displayed a rightward shift after reading a RTL prime. In contrast, after reading a LTR prime a leftward bias was observed. After the first second, the bias was largely reduced or even reversed up to the end of target presentation. This result suggests that reading direction of a text prime influences later exploration of complex stimuli. In experiment 2, we investigated whether the difference of native and secondary language influences the results. For this purpose, we measured German/ English bilinguals with LTR reading direction in both languages. Here, participants showed leftward bias after reading LTR texts in either case. This demonstrates that for the present purpose the difference between native and secondary language is not important. In the final experiment, we investigate the relative influence of principal and actual reading direction. LTR bilingual participants were presented with normal and mirrored texts. Upon reading the primes, reading direction differed markedly, reflecting mirrored and not mirrored conditions. However, we did not observe significant differences in the leftward bias. This experiment demonstrates that the principal, not the actual reading direction influences the asymmetry on later complex target images. In conclusion, our results revealed that there is an influence of language direction- not the scanning direction- on viewing behavior of complex images that do not contain text elements.

Direction of Horizontal Fixation Points

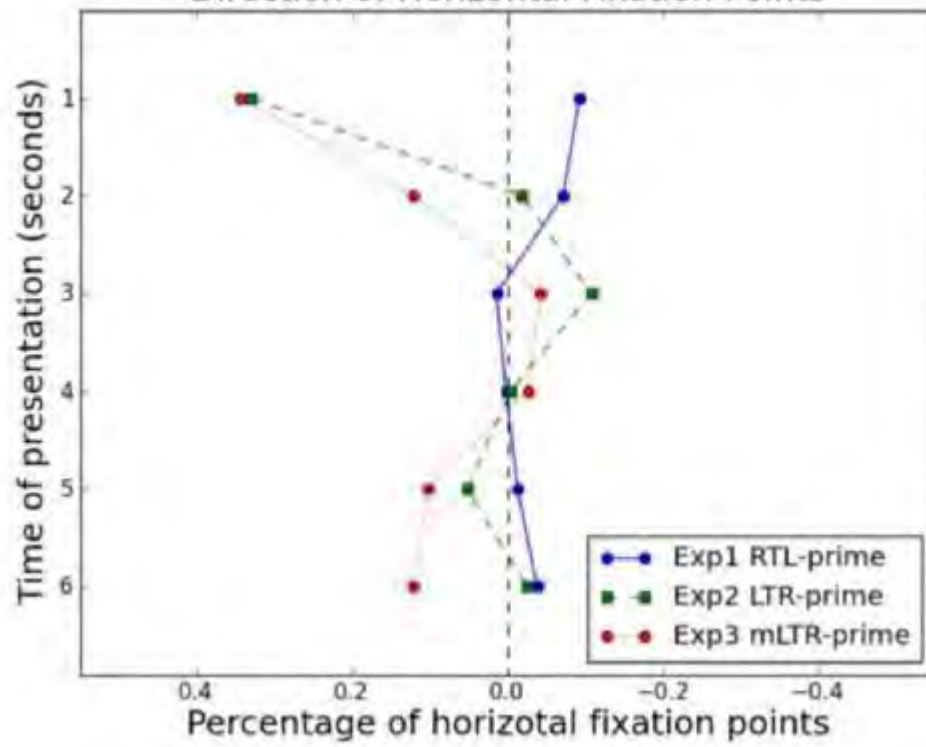

Influence of a cortical lesion in the motor cortex on visual cortex plasticity in adult mice.

Justyna Pielecka-Fortuna, Evgenia Kalogeraki¹, Siegrid Löwel¹

¹Georg-August-Universität Göttingen, Systems Neuroscience, Bernstein Fokus Neurotechnologie, Von-Siebold-Str. 4, 37075 Göttingen, Germany

The primary visual cortex (V1) has been extensively used to study neuronal plasticity, a phenomenon that is most pronounced in juveniles, yet still present in adulthood. The ability of the adult brain to undergo plastic changes is of particular interest, especially with regard to recovery from brain injuries or improving learning and memory in the aging brain. Recent studies from our laboratory have shown that a small cortical lesion in the primary somatosensory cortex prevented plastic changes in the mouse visual system (Greifzu et al., 2011). Specifically, monocular deprivation (MD) did no longer induce an ocular dominance (OD) shift in V1 towards the open eye. Similarly, neither visual acuity nor contrast sensitivity through the open eye improved when assessed behaviorally by optometry. To assess whether these plasticity impairments do only happen when the lesion is located relatively close to V1, we tested the effect of a cortical lesion induced by photothrombosis in the supplementary motor cortex (M2), about 3 mm anterior to V1. Size and location of the cortical lesions were analyzed under the microscope in Nissl stained brain sections. To challenge plasticity mechanisms we monocularly deprived mice for 7 days. To monitor and quantify changes in visual cortex we used *in vivo* optical imaging of intrinsic signals. In addition, visual abilities were checked daily during MD by optometry. Four groups of adult C57Bl/6J mice (PD 70-100) were examined: Sham-treated mice with and without MD (control+MD/control), mice with a photothrombotically induced stroke with and without MD (PT+MD/PT). In agreement with our previous report, 7 days of MD induced a significant OD-shift in control mice, and these mice also showed significant improvements in both visual acuity and contrast sensitivity through their open eye. In contrast, mice with a photothrombotically induced stroke lesion in M2 did not show OD-shifts after 7 days of MD. Additionally their ability to improve both visual acuity and contrast sensitivity of the open eye was partially reduced. Taken together, our data show that even a very small cortical lesion restricted to the superficial cortical layers and more than 3mm anterior to V1 can still impair cortical plasticity in V1 and at least partly impairs learning-induced visual improvements in adult mice. Thus both phenomena cannot only depend on modality-specific and local networks but are clearly influenced by long-ranging interactions even from distant motor cortex.

Supported by the BMBF 1GQ0921.

Reelin-deficient mice possess normal visual acuity and visual cortical maps

Ann-Kristin Martens, Bianka Goetze¹, Karl-Friedrich Schmidt¹, Robin Wagener²,
Jochen Staiger², Siegrid Löwel¹

¹Bernstein Focus for Neurotechnology and School of Biology(BFNT), Georg-August Universität Göttingen/Germany

²Department Neuroanatomy, Universitätsmedizin Göttingen/Germany

Reeler (rl^{-/-}) mutant mice are deficient in the extracellular matrix protein Reelin that regulates neuronal migration in early neocortical development¹. While the resulting structural abnormalities have long been described as an inversion of cortical layers², a recent study has shown that the lamination in the primary somatosensory cortex is not just inverted but highly disturbed³. The retina of *reeler* mice reveals a normal cellular organization. Yet there are abnormalities in the distribution of synaptic endings with ectopically located synapses and a reduced number of rod bipolar cells⁴.

Given the severe laminar and retinal abnormalities we wondered whether this might affect vision and visually evoked activity in the primary visual cortex (V1) of the mutant mice. To examine visual capabilities of *reeler* (rl^{-/-}) mice we measured visual acuity, contrast sensitivity and temporal resolution using a virtual-reality optomotor system. In addition, we visualized cortical activity maps in primary visual cortex (V1) and analyzed ocular dominance in the binocular region of V1 using intrinsic signal optical imaging. The data from *reeler* (rl^{-/-}) mice were compared to both wild-type (rl^{+/+}) and heterozygote (rl^{+/-}) mice.

Visual acuity, contrast sensitivity and temporal resolution were similar in all analyzed genotypes. In addition, the optically recorded V1-maps in *reeler* mice were indistinguishable from the other genotypes: both magnitude of cortical activation and the quality of the retinotopic maps was as previously described for C57Bl/6 mice. Finally, there was also no difference in ocular dominance between mutant, wild-type and heterozygote mice.

Taken together, our findings indicate that visual processing in *reeler* mice does not seem to be specifically impaired despite the highly disorganized lamination in their V1. Geniculocortical afferents are obviously able to find their correct target neurons even if those are located ectopically. *Reeler* V1 subserves normal cortical activation, retinotopic maps and ocular dominance. Thus, it seems that a correct wiring can be achieved without the requirement of intact cortical lamination.

Supported by the BMBF 1Q0810, CNMPB-B1

¹D'Arcangelo (2005) Int Rev Neurobiol 71:383, ²Caviness & Sidman (1973) J Comp Neurol 148:141,

³Wagener et al. (2010) J Neurosci 30:15700, ⁴Rice et al. (2001) Neuron 31:929

Perisaccadic response modulations in area V4 of the macaque monkey

Steffen Klingenhoefer, Markus Wittenberg¹, Thomas Wachtler², Frank Bremmer¹

¹Philipps-University Marburg, Dept. Neurophysics, Karl-von-Frisch-Str. 8a, 35043 Marburg, Germany

²Ludwig-Maximilians-University, Muenchen, Germany

Changes in a visual scene, caused by suddenly appearing or moving stimuli, are salient events. This stands in stark contrast to alterations of the visual input that are a consequence of saccadic eye movements: they usually go unnoticed. The effect of apparent perceptual stability during saccades is typically attributed to saccadic suppression, i.e. a decrease in visual sensitivity accompanying the eye movement. It was the purpose of this study to further investigate the neural basis of this phenomenon. To this end, we recorded multi-unit activity (MUA) in area V4 of two macaque monkeys that was evoked by a dynamic luminance stimulus (white vertical bars that were randomly repositioned at a frequency of 100 Hz; bar size: 0.4° x 3.0°, display size: 36° x 27°). We analyzed the stimulus induced activity while the animals were fixating as well as prior to, during, and shortly after visually guided saccades of 12° amplitude. After stimulus onset, the MUAs showed a transient response which was followed by a decline in activity until a constant level of sustained activity was reached, a phenomenon called neuronal adaptation. The sustained activity did not decrease perisaccadically, i.e., we did not find any evidence for saccadic suppression. Instead, we typically observed a slight pre- and a pronounced postsaccadic increase in activity. The postsaccadic activity reached almost the same level and closely paralleled the time course of the response after stimulus onset. However, there was a notable modification to this: postsaccadic activity lacked the initial transient phase of the stimulus onset response observed during steady fixation. This effect was most evident in recording sites with peripheral receptive fields. We conclude that saccades can release neuronal adaptation in area V4, even if the receptive fields are continuously stimulated during the eye movement. In this case, the absence of transient response components distinguishes stable from newly appearing stimuli, a mechanism that might contribute to perceptual stability across saccadic eye movements.

A computational model of light scatter and image formation in the human eye

Ismael Kelly Pérez, Annette Werner¹

¹Universität Tübingen, Institute for Ophthalmic Research, Frondsbergstrasse 23, 72070 Tuebingen, Germany

Increased density and consequently increased light scattering of the human lens is one of the main causes of the deterioration of visual performances with age. It is therefore important to distinguish their effects from those of disease related neuronal changes of the retina. The most important parameters that affect scattering are the size and number of lenticular particles, which can, until now, only be determined indirectly through their effect on the images seen with the slit lamp and with the Scheimpflug cataract imaging system. We developed a computational model, which describes the amount of scatter and its affects on image formation in human cataract eyes. The model simulates the scattering effect on the light distribution intensity on the retina and exit pupil planes, when thousands of photons are sent into the eye and interact with small particles that are inside the lens. The main components of the model are: Monte Carlo simulation, ray tracing, spatial point process, Mie scattering and a waveguide-scattering model. As we increase the wavelength the effect of the scattering is reduced in the center of the image while increasing in the edges. The model has the potential to predict the size and number of lenticular particles. This will allow for better diagnosis of the origin of visual performance loss as due to optical or neuronal factors.

Dark exposure rescues ocular dominance plasticity in the visual cortex of adult mice in an age-dependent manner

Sophia Katharina Stodieck, Bianka Goetze¹, Franziska Greifzu¹, Hugo Cruces-Solis^{2,3}, Karl-Friedrich Schmidt¹, Siegrid Löwel¹

¹Bernstein Focus Neurotechnology (BFNT) and Johann-Friedrich-Blumenbach Institut für Zoologie und Anthropologie, Georg-August-Universität Göttingen/Germany

²International Max Planck Research School for Neurosciences, Göttingen Graduate School for Neurosciences and Molecular Biosciences, 37077 Göttingen, Germany;

³Max Planck Institute for Experimental Medicine, Hermann-Rein Str. 3, 37075 Göttingen, Germany

In the primary visual cortex (V1), monocular deprivation (MD) induces a shift in the ocular dominance (OD) of binocular neurons towards the open eye. In V1 of C57Bl/6J mice, this OD-plasticity is maximal in juveniles at 4 weeks of age, declines in 2-3 months old animals ("adult" OD-plasticity) and is absent beyond postnatal day (PD) 110 even after longer deprivation times up to 14 days¹. Recently, He et al.(2006)² showed that juvenile-like OD-plasticity can be restored in the visual cortex of adult rats (To test whether dark exposure is also effective in mice, we raised mice until either 3 (3M) or 4-5 months of age (5M) , transferred them into a dark room for 10-14 days and then checked with intrinsic signal optical imaging whether 4 days (3M) or 7 days (5M) of MD were sufficient to induce a significant OD-shift towards the open eye. Animals that stayed in their home cages (light-reared=LR) served as controls. In addition, we measured visual abilities with optometry before and daily during MD. Finally, we investigated the number of both parvalbuminergic interneurons and perineuronal nets in V1 in all experimental groups.

Interestingly, dark exposure (DE) increased OD-plasticity in an age-dependent manner: In 3M animals, DE did not induce significant OD-shifts after 4d of MD: the OD-index (ODI) was 0.27 ± 0.04 with and 0.27 ± 0.02 without MD. In contrast, in 5M animals, DE induced highly significant OD-shifts after 7d of MD: the ODI was 0.05 ± 0.024 with MD and 0.27 ± 0.0 without MD ($p < 0.001$), whereas ODIs in age-matched LR animals did not change after MD (ODI= 0.30 ± 0.026 with and 0.28 ± 0.013 without MD). Quantitative analyses of V1-activation revealed that the OD-shift was primarily mediated by an increase of open eye responses, thus demonstrating signs of an adult OD-shift. The behavioral tests revealed that visual acuity and contrast sensitivity through the open eye increased in both LR- and DE-mice after MD and did not differ between groups. Interestingly, the increased OD-plasticity in the older DE-animals was accompanied by a significant reduction in the number of both parvalbuminergic interneurons in V1 compared to LR-controls. This strongly suggested reduced intracortical inhibition as the likely mechanism mediating the restored plasticity. To test this idea we applied diazepam after DE and for controls we injected saline. Diazepam treatment indeed completely prevented the DE-induced OD-shifts after MD. Our results demonstrate for the first time that dark exposure can reactivate OD-plasticity also in mice. Interestingly, the reactivation is age-dependent: it is present in over 4-month-old but not in 3-month-old mice. The observed OD-shifts were as strong as previously only observed in 4-week-old critical period mice and were mediated by an increase in open eye responses in V1. Restored OD-plasticity was accompanied by a reduction of both parvalbuminergic neurons and perineuronal nets and was prevented by increasing intracortical inhibition with diazepam. In summary, short-term DE in adult mice lead to both anatomical and physiological changes in V1 that restored OD-plasticity in an age-dependent way. The restored plasticity was most likely mediated by a reduction of intracortical inhibition.

Supported by BMBF 1GQ0810, 1GQ0921

¹Lehmann & Löwel (2008) PLoSOne 3:e3120, ²He et al (2006) J. Neurosci. 26:2951, ³Hensch (2005) Nat. Rev. Neurosci. 6:877

Effects of locomotion on response properties and functional connectivity in mouse primary visual cortex

Sinem Erisken, Agne Vaiceliunaite^{1,2}, Florian Franzen¹, Alexandra Wal¹, Steffen Katzner¹, Laura Busse¹

¹University of Tübingen, Centre for Integrative Neuroscience, Otfried-Müller Str. 25, 72076 Tübingen, Germany

²Department of Neurobiology and Biophysics, Faculty of Natural Sciences, Vilnius University, Lithuania

Throughout primate visual cortex, tuning curves of individual neurons and functional connectivity in the network do not only depend on sensory input but are also profoundly modulated by behavioral state. In primary visual cortex (V1) of the rodent, one such modulatory influence is locomotion, which has been shown to enhance neural activity (Niell & Stryker, 2010; Keller et al., 2012). Here, we compare the effects of locomotion in mouse V1 to the well-documented effects of attention in primates: we characterized the effects of locomotion on tuning for stimulus orientation and contrast, and asked how locomotion affects functional connectivity between pairs of neurons.

To investigate response modulation by locomotion, we used tetrodes and linear multielectrode arrays to record extracellular activity from single neurons in the primary visual cortex of awake, behaving mice. We compared conditions, in which the head-fixed animal ran on a spherical treadmill or remained quiescent.

Similar to previous reports, we found that locomotion increases neural activity in mouse area V1. When we separated trials based on locomotion, we found that both spontaneous activity and responses to drifting gratings were enhanced during periods of running compared to quiescence. We next assessed the influence of locomotion on tuning for stimulus orientation and contrast and found that running increased direction selectivity ($DSI_{\text{moving}} = 0.32 \pm 0.03$, $DSI_{\text{still}} = 0.25 \pm 0.03$; $p = 0.0032$, t-test) and steepened contrast response functions ($n_{\text{moving}} = 4.13 \pm 0.52$, $n_{\text{still}} = 2.51 \pm 0.37$; $p = 0.017$, t-test).

Finally, we asked how locomotion influences functional connectivity and measured correlated response variability in pairs of neurons (noise correlations). We found that, in the absence of visual input, noise correlations during locomotion ($r_{\text{sc,moving}} = .074 \pm .0088$) were higher than during periods of immobility ($r_{\text{sc,still}} = .034 \pm .0099$), suggesting a more synchronous network during periods of running.

In conclusion, our results contribute to the notion that even the earliest stage of cortical visual processing does not only reflect the stimulus input but is also strongly modulated by behavioral state.

Human and non-human primate homologues of stereomotion in cortex

Sylvia van Stijn, Ralf Deichman³, Wolf Singer², Hwan Sean Lee²

¹Ernst Strüngmann Inst. (ESI) In Cooperation With Max Planck Society, Prof. Singer, Deutschordenstrasse 46, 60528 Frankfurt am Main, Germany

²Max Planck Inst. for Brain Res., Frankfurt am Main, Germany;

³Brain Imaging Ctr., Univ. of Frankfurt, Frankfurt am Main, Germany

Motion on a two dimensional plane has been well studied and is known to involve brain region MT, but motion in depth has been studied less intensively. In our fMRI study (reported at SFN 2010) we have shown that motion in depth in human subjects involves two regions in ipsilateral sulcus and temporal sulcus, that are working together. With the use of retinotopic mapping and ipsilateral representation of optic flow, we have further identified these regions as being V3B and MST.

In this fMRI study we targeted the neural correlates of stereomotion in non-human primates. We presented one monkey (female, macaca mulatta) with multilayered random dot stereogram (RDS) stimuli while fixating a center target and performing a color change detection task. RDSs represented a surface moving in depth or random dots in random depths alternating in a blocked design. Subsequently we used the unilateral representation of optic flow to functionally localize region MST and match the location with the region activated by motion in depth.

We located the areas in the non-human primate that are involved in the processing of motion in depth. These areas are as in human subjects, in the ipsilateral sulcus and temporal sulcus and the latter also shows a match with the ipsilateral representation of optic flow.

Discrepant reach goal representations in local field potentials and spiking activity in parietal reach region

Alexander Gail, Christian Klaes², Stephanie Westendorff³

¹German Primate Center, BCCN Göttingen, Sensorimotor Group, Kellnerweg 4, 37077 Goettingen, Germany

²California Institute of Technology, Division of Biology, 1200 E California Blvd, Pasadena, USA

³York University, Department of Biology, 4700 Keele St, Toronto, Canada

The posterior parietal cortex (PPC) plays a key role for transforming multimodal sensory information into motor goals. Individual neurons in the parietal reach region (PRR) are often directionally tuned during planning of reaches (Snyder et al. 1997). This planning activity encodes the spatial location of a pending reach endpoint rather than the instruction stimulus, demonstrating that it represents motor-goal information (Gail and Andersen 2006). Additionally to spiking activity local field potentials (LFPs) have been proposed to reflect cortical function. Understanding of the relationship of LFP tuning to tuning properties of spiking activity is critical for its interpretation. Here we test, first, if LFP tuning also reflects pending motor goals, like spiking activity does, and, second, how consistent both signals are in terms of their selectivity for the direction of planned reach movements.

Previous studies have analysed LFP activity in PRR during movement planning and execution (Scherberger et al. 2005; Hwang and Andersen 2012). However, previous task designs did not allow dissociating the encoding the directional information contained in the spatial visual input or its memory from the encoding of the direction of the reach goal, as it was shown for spiking data (Gail and Andersen 2006). Here, we used a memory-guided anti-reach task to dissociate spatial tuning related to a cue position from spatial tuning related to the position of the reach goal in PRR of four rhesus monkeys. We used time-resolved Fourier decomposition to test if a dynamic transition between cue and motor-goal encoding would be present at any signal frequency or spread across separated frequency bands.

The spectral amplitude of LFP in a frequency range of 20-40 Hz was encoding the position of the future motor-goal rather than the position of the preceding visual cue during motor planning. While this result was consistent across four monkeys, the strength of the reach-goal tuning and its spectro-temporal patterns differed substantially between monkeys. Especially, the distribution of preferred directions (PD) of LFP spectral tuning was highly non-uniform within each single monkey, and the observed bias in the PD distributions varied between the monkeys. In contrast to previous reports, this bias in PD was not centered at the reach direction contralateral to the used hand. Instead, in each monkey the bias was centered at a different reach direction, without a noticeable correlation to any of the tested behavioral parameters. In contrast, the strength of reach goal tuning measured with spiking activity was consistent across all four monkeys and PD distributions were uniform.

Our results demonstrate that LFP and spiking during reach planning in PRR are similar in the sense that both signals encoded the future movement. But reach-goal tuning differs substantially between LFP and spiking in the sense that their PDs are inconsistent. Similarly, it had been shown previously for V1 that LFP and spike-based tuning are not always consistent (Jia et al. 2011). These results suggest that reach-goal tuning in LFP of PRR, and likely also LFP tuning in other brain areas, is not simply a summation of the spiking activity of multiple cells, but is based on an additional independent code.

Gail & Andersen 2006 J Neurosci 26:9376

Hwang & Andersen 2012 J Neurophysiol107:836

Jia et al. 2011 J Neurosci 31:9390
Scherberger et al. 2005 Neuron 46:347
Snyder et al. 1997 Nature 386:167

Effects of interhemispheric connections on the contrast response function in cat primary visual cortex

Thomas Wunderle, David Eriksson^{1,2}, Christiane Peiker², Kerstin E. Schmidt^{2,3}

¹Ernst Strüngmann Institute (ESI) for Neuroscience, Fries Lab, Deutschordenstraße 46, 60528 Frankfurt, Germany

²MaxPlanck Institut für Hirnforschung, Deutschordenstraße 46, 60528 Frankfurt, Germany

³BRAIN INSTITUTE

Federal University of Rio Grande do Norte, Av. Nascimento de Castro, 2155 - 59056-450 - Natal / RN - Brazil

Information processing in the central nervous system relies on a combination of various signal streams. That is a given neuron in sensory cortex integrates over synaptic inputs of different origins. For example, inputs could be feedforward, feedback, recurrent as well as interhemispheric in nature. Here, we asked how interhemispheric inputs shape the output of a cortical neuron.

To this end, we recorded from cat visual cortex (area 17 and 18) while controlling interhemispheric input arriving via the corpus callosum. This was done by reversible deactivation of a restricted part of visual cortex contralateral to the recorded area using a surface cryoloop. Using this setup, we recently have shown that interhemispheric input is combined with ipsilateral input in a multiplicative manner. This conclusion was based on our observation of a predominant multiplicative scaling of orientation tuning curves during thermal deactivation. However, because orientation tuning is an emergent property of visual cortex, we could not distinguish if this gain control happened at a neurons input, its output or at both places.

Changes in input gain or output gain can be distinguished by comparing the contrast response function (CRF) of a neuron before and during removal of a specific, i.e. interhemispheric, input. If this manipulation changes the gain at the input site, it would effectively multiply the stimulus contrast for that neuron ("contrast gain model"). This would be visible as a horizontal shift of its CRF on a logarithmic contrast axis, i.e. a change in the semisaturation constant ($c50$) without a change in its maximal response (R_{max}). If, on the other hand, a gain change happened at the output, responses at all contrast would be multiplied with a constant factor ("response gain model"). In this case, the CRF of that neuron would be shifted vertically, without a change in its semisaturation constant.

We recorded 142 multi units and obtained CRFs by presenting drifting gratings at different contrasts before and during removal of interhemispheric input. CRFs were then fit with hyperbolic ratio functions to obtain the parameters $c50$ and R_{max} from the fitted parameters. On average we found a 34% increase in $c50$ and a 19% decrease in R_{max} . Those results indicate both a change in input and output gain. We therefore tested, for each neuron, how well it followed a pure contrast gain or response gain compared to a full model including both, a change in $c50$ and R_{max} . We found that 22% of the neurons followed a contrast gain mechanism, 30% were better explained by a response gain and 16% were well described by either model. For the remaining 32% of neurons, neither model alone could explain the change in the CRF. Interestingly, the type of scaling also had implications for the information content about the orientation presented. Neurons following the contrast gain mechanism had a substantial reduction in their mutual information at low contrasts compared to high contrasts. This was not the case for those neurons following a response gain mechanism.

We conclude that interhemispheric input changes the response properties of neurons in primary visual cortex in various ways: It can change the gain at the input, the output or at both sites. Which of the three cases dominates might be a result of the balance between direct interhemispheric and indirect recurrent input to a specific neuron. This balance is possibly not fixed, but state-dependent.

Reversals of illusory depth or illusory rotation in structure-from-motion: an MEG study

Alexander Pastukhov, Mandy Bartsch², Solveiga Stonkute¹, Jens Max Hopf^{2,3}, Jochen Braun¹

¹Otto-von-Guericke Universität, Cognitive Biology, Magdeburg, Germany

²Leibniz Institute for Neurobiology, Magdeburg, Germany

³Otto-von-Guericke Universität, Department of Neurology, Magdeburg, Germany

Structure-from-motion (SFM) is a visual illusion in which 2D motion produces a vivid image of an illusory volume rotation in depth. Perception of SFM activates a network of occipital and extra-striatal areas, including hMT+/V5, lateral occipital complex (LO), various sub-regions of intraparietal sulcus, as well as other visual and cross-modal areas (Orban, 2011). This distributed activation is not surprising, as SFM involves representations of 1) 2D motion, 2) 3D illusory rotation, 3) illusory depth of individual dots, 4) illusory shape they interpolate to, and 5) binding between dots and interpolated shape.

Here we have used MEG recordings in order to examine neural correlates of illusory rotation and of illusory depth by looking at the neural correlates of changes of their respective states. To this end, we have used a forced ambiguous switch paradigm – a reversal of 2D on-screen motion which forces visual system to selectively reverse either illusory rotation alone, or illusory depth alone (Pastukhov, Vonau, & Braun, 2012; Stonkute, Braun, & Pastukhov, 2012). This dramatically simplifies analysis and makes it possible to establish one-to-one relationship between neural correlates and perceptual components.

Results of current source density analysis are summarized on Figure 1 in their temporal order (top row: illusory rotation switch outcome, bottom row: illusory depth switch outcome). We observe significant difference in activation in areas hMT/V5 at 177 ms, V3A at 205 ms and lateral occipital complex (LO) at 225 ms.

The only region to show higher activation for illusory rotation switch was area hMT/V5. Accordingly, we conclude that its activation reflects changes in representation of 3D illusory rotation. Two other areas show higher activation for illusory depth switch. We interpret activation of V3A as reflecting adjustment to the 3D spatial representation of individual dots. In turn, a later activation in area LO reflects binding between individual dots and interpolated coherent object.

We also observed a difference in activation in right inferior parietal (rIP) region, occurring at 201 ms. It is likely to reflect different levels of uncertainty associated with two perceptual switches. In agreement with prior work (Knapen, Brascamp, Pearson, van Ee, & Blake, 2011), we find higher activation for illusory depth, which has a pronounced period of uncertainty, than for switch of illusory rotation (minimal uncertainty).

References:

- Knapen, T., Brascamp, J. W., Pearson, J., van Ee, R., & Blake, R. (2011). The Role of Frontal and Parietal Brain Areas in Bistable Perception. *Journal of Neuroscience*, 31(28), 10293–10301. doi:10.1523/JNEUROSCI.1727-11.2011
- Orban, G. A. (2011). The extraction of 3D shape in the visual system of human and nonhuman primates. *Annual review of neuroscience*, 34, 361–88. doi:10.1146/annurev-neuro-061010-113819
- Pastukhov, A., Vonau, V., & Braun, J. (2012). Believable change: Bistable reversals are governed by

physical plausibility. Journal of vision, 12(1), 17. doi:10.1167/12.1.17

Stonkute, S., Braun, J., & Pastukhov, A. (2012). The Role of Attention in Ambiguous Reversals of Structure-From-Motion. (S. B. Hamed, Ed.) PLoS ONE, 7(5), e37734. doi:10.1371/journal.pone.0037734

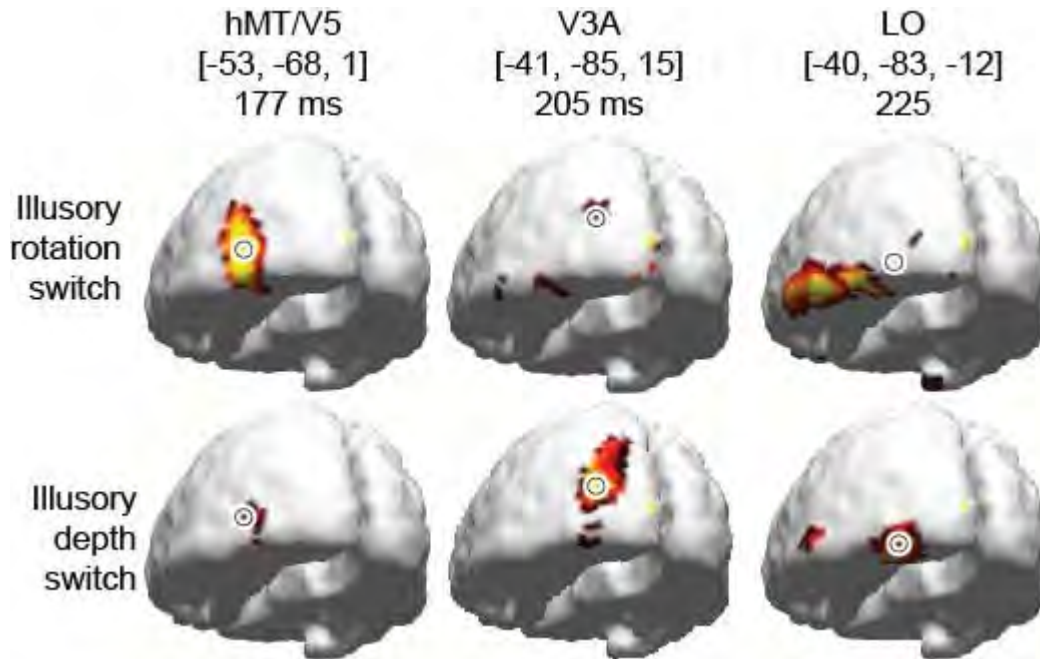

Stimulus representations in body-selective regions of the macaque and human cortex assessed with event-related fMRI

Jan Jastorff, Ivo D. Popivanov¹, Natalie Caspari¹, Guy A. Orban^{1,2}, Wim Vanduffel^{1,3,4},
Rufin Vogels¹

¹KU Leuven, Neurophysiology, Herestraat 49, bus 1021, 3000 Leuven, Belgium

²University of Parma, Medical School, Parma, Italy ³MGH Martinos Ctr., Charlestown, MA, USA ⁴Harvard Med. Sch., Boston, MA, USA

Functional imaging studies in humans and monkeys have shown category-selective regions in the temporal cortex, in particular for faces and bodies. Although body-selective regions have been studied repeatedly, we still know little about the functional properties of such regions and their correspondence across the two species. To address this question, we investigated the selectivity and spatial distribution of body and face patches testing an identical set of 200 stimuli in both species.

Achromatic images of headless Monkey and Human Bodies, two sets of man-made Objects – matched for each of the body categories, Monkey and Human Faces, four-legged Mammals, Birds, Fruits, and Moore Sculptures were shown to 7 human subjects and 4 macaque monkeys in an event related design. All stimuli were matched for area, aspect ratio, luminance and contrast. Stimuli were presented for 480 ms with an interstimulus interval jittering between 2500 ms and 3500 ms in a pseudo-random order. 32 runs were acquired in each human and 100 in each monkey. In addition, body selective regions were localized using a block design in both species.

Using the localizer runs, we identified two regions in the middle and anterior Superior Temporal Sulcus (STS) of the monkey that were more strongly activated by monkey bodies compared to manmade objects. These two regions partially overlapped with regions that were more activated by faces than manmade objects. Multivoxel-pattern analyses using the data from the event-related runs showed that both body-selective regions primarily distinguished faces from other inanimate and animate objects, including bodies. A secondary distinction was present between inanimate objects and bodies in the middle STS body region. The category-based clustering was poorer in the anterior compared to the middle STS body-selective regions.

In humans, the extrastriate and fusiform body areas (EBA/FBA) were defined using the body localizer. Multivoxel-pattern analysis revealed that the EBA primarily distinguished between animate and inanimate stimuli with a secondary distinction between bodies and faces. The FBA primarily distinguished faces, animals and birds from the other categories with a secondary distinction between bodies/sculptures and the other inanimate stimuli. At the individual stimulus level, both EBA and FBA showed three main cluster, almost perfectly separating the 80 body stimuli, the 40 face stimuli and the 80 inanimate stimuli. Using the event related design, we identified four additional body selective regions in the human brain, located in the anterior temporal cortex, the precuneus, the medial prefrontal cortex and the posterior medial orbito-frontal cortex. In contrast to the EBA and FBA, which showed strongest activation for monkey and human bodies, animals and birds, these additional regions exhibited significantly stronger activation for human bodies and human faces compared to all other categories.

Overall, these data indicate strong spatial clustering of animate categories in the macaque STS and human occipito-temporal cortex. Even though the clustering results were slightly different between humans and monkeys, the overall dissimilarity matrices of EBA and the mid STS body patch were highly congruent.

Different extraocular motoneuronal subgroups control fast and slow phase components of the optokinetic reflex in *Xenopus laevis*

Johanna Miriam Schuller, Alexander Georg Knorr⁴, Stefan Glasauer⁴, Hans Straka³

¹DFG Research Training Group 1091, Klinikum Großhadern, Ludwig-Maximilians-University Munich, Germany

²Graduate School of Systemic Neurosciences, Ludwig-Maximilians-University Munich, Germany

³Department Biology II, Ludwig-Maximilians-University Munich, Germany

⁴Center of Sensorimotor Research, Clinical Neurosciences, Ludwig-Maximilians-University Munich, Germany

During vertebrate locomotion, retinal image displacements are minimized by eye movements resulting from the activation of visuo-vestibular reflexes. An essential condition to generate these dynamically diverse eye movements, responsible for gaze stabilization, is the presence of motoneuronal populations that cover a wide range of dynamic properties. The horizontal optokinetic reflex (OKR) with its alternating slow following and fast resetting phases offers an ideal motor behavior to study the recruitment of task-specific neuronal subunits. Here, we studied the functional organization of extraocular motoneuronal activation during OKR performance in *Xenopus laevis* tadpoles in order to identify potential subgroups responsible for different dynamic components of the visually-elicited eye movements. Velocity step and sinusoidal optokinetic stimulation (0.2-50°/s; 0.032-1 Hz) by rotation of a vertically striped drum evoked eye movements in semi-intact preparations with a functional visual system. Simultaneous motion recordings of one eye and extracellular multiple-unit recordings of the contralateral extraocular nerves during optokinetic stimulation facilitated direct comparison of motoneuronal commands and effective behavioral output. Ocular motor responses captured with a camera at 50 Hz and quantified by computerized video analysis revealed a horizontal ocular motor range of ~50° and a maximal gain of 0.64 at 2°/s constant stimulus velocity. Fast phases with a velocity of up to 350°/s regularly interrupted the slow phases. Extracellular recordings of the lateral rectus nerve revealed task-specific contributions of individual motor units during slow and fast phase components, respectively. Single spike analysis, along with the determination of activation thresholds, response properties and discharge regularity, confirmed a differential recruitment of motor units with different discharge behavior and suggests the presence of distinct subgroups with specific contributions during motor behavior. Accordingly, the analysis revealed a specific extraocular motoneuronal subgroup that was only active during fast phases but not during slow following phases, while other motoneurons fired only during the latter OKR component, although at different thresholds. Based on these data a computational model of the underlying neural circuitry was established, effectively simulating the recruitment and interaction of separate subgroups involved in generating appropriate optokinetic responses on a systems level with integrating structures responsible for both eye motion components. The presence of distinctly different motoneuronal subgroups provide the necessary condition to generate the large dynamic range of eye movements including slow following and fast resetting components of the OKR. The functional extension of the computational model will offer further insight into the differential extraocular organization and adaptive changes of the optokinetic system during ontogeny that can be tested in empiric experiments.

Social experience modulates adult ocular dominance plasticity in mice

Konrad Lehmann, Jenny Balog¹

¹Friedrich Schiller Universität Jena, Institut für Allgemeine Zoologie und Tierphysiologie, Erbertstr. 1, 07743 Jena, Germany

Ocular dominance (OD) plasticity in the binocular part of the visual cortex, induced by monocular deprivation (MD), has a critical period in pre-weaning infancy and ceases at the end of adolescence in mice housed in a standard laboratory environment (Lehmann and Löwel, 2008). In recent years, however, numerous systemic influences have been found that maintain or reinstate OD plasticity in adult rodents. E.g., housing in an enriched environment revives OD plasticity in adult rats (Sale et al., 2007). More detailed investigations indicate that of the many features of an enriched environment, locomotion, visual stimulation and perceptual learning induce visual cortical plasticity, whereas social experience is without effect (Baroncelli et al., 2012).

Here, we report the opposing result in mice. Adult male animals lived individually or in pairs during the MD period. As an additional factor, they were kept either in a small cage or in a large, featureless arena. Ocular dominance was assessed by optical imaging of intrinsic signals.

Even in mice older than 100 days, four days of MD induced a significant OD shift if the animals had been kept pairwise in the open arena. Paired animals kept in cages, and individually housed animals in either environment did not show OD plasticity. Further investigations showed that the amount of locomotion was not different between pairwise and individually kept animals in the open arena. Moreover, providing a running wheel in a small cage did not reinstate OD plasticity. Thus, it seems that certain aspects of social experience modulate adult visual cortical plasticity, whereas increased locomotion by itself has no effect on OD plasticity in mice.

Baroncelli L, Bonaccorsi J, Milanese M, Bonifacino T, Giribaldi F, Manno I, Cenni MC, Berardi N, Bonanno G, Maffei L, Sale A (2012) Enriched experience and recovery from amblyopia in adult rats: impact of motor, social and sensory components. *Neuropharmacology* 62:2388-2397.

Lehmann K, Löwel S (2008) Age-dependent ocular dominance plasticity in adult mice. *PLoS One* 3:e3120.

Sale A, Maya Vetencourt JF, Medini P, Cenni MC, Baroncelli L, De Pasquale R, Maffei L (2007) Environmental enrichment in adulthood promotes amblyopia recovery through a reduction of intracortical inhibition. *Nat Neurosci* 10:679-681.

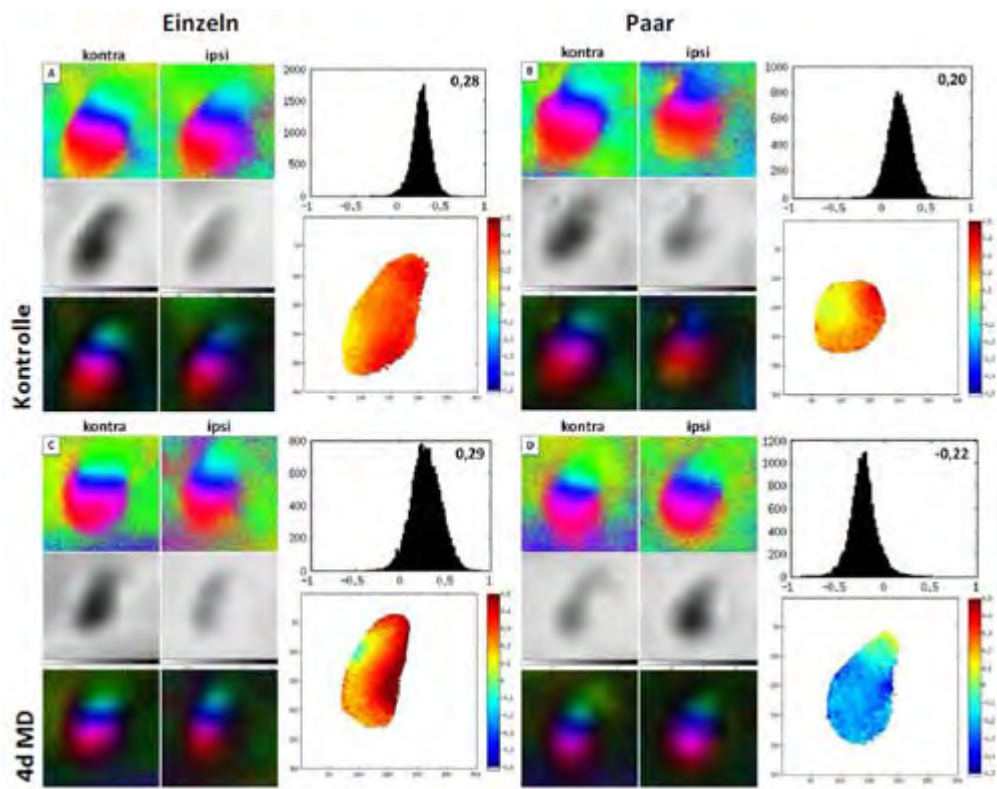

Influence of Intermittent Theta-Burst TMS on Rat Visual Performance and Neuronal Activity Marker Expression when Applied during the Critical Cortical Period

Diana Veronica Castillo-Padilla, Klaus Funke¹

¹Ruhr-University Bochum, Neurophysiology, Universitaetsstrasse 150, 44801 Bochum, Germany

Visual cortex critical period (CP) is characterized as a state of early neuronal network plasticity during which first sensory experience imprints network connections for fundamental steps of sensory processing like spatially matched integration of binocular inputs and orientation tuning [1]. Cortical plasticity is considerably reduced thereafter and malfunction of sensory input during CP, e.g. by weakness of one eye, can lead to lifelong amblyopia. Total deprivation of sensory input can prolong this period of enhanced plasticity while artificial activation of the cortical network may cause a preterm closure. Transcranial Magnetic Stimulation (TMS) can be used to activate cortical networks non-invasively and repetitive stimulation (rTMS) induces changes in cortical excitability depending on the temporal pattern used. Our previous studies in rats demonstrated that an intermittent theta-burst stimulation protocol (iTBS) causes a strong subchronic reduction in cortical parvalbumin (PV), calbindin (CB) and GAD67 (67kD isoform of glutamic acid decarboxylase, GABA-synthesizing enzyme) expression, indicating that activity of inhibitory interneurons may be reduced [2]. This state improved spatiotactile learning in rats, associated with a recovery of PV [3].

Here, we tested if iTBS rTMS applied during the CP of rat visual cortex may affect the rat's visual performance in subsequent visual training, and if the expression of distinct cortical activity and plasticity markers may be changed. When eyes were still closed, rats were dark-reared (DR) for 14 days to keep up and prolong the critical period. In different experimental groups, dark rearing was combined with daily exploration of a tactile enriched environment (tEE) and either sham or verum iTBS rTMS. One half of the groups directly underwent immunohistochemical (IHC) analysis of marker proteins, the other half performed a 4-days visual training, and visual acuity was tested at the 5th day before IHC analysis followed.

Results: Rats dark reared in a standard cage receiving either none, or sham iTBS showed a visual performance at chance level (43% correct). Rats allowed to repeatedly explore the tEE during DR (none, or sham iTBS) reached 75% correct choices while rats receiving verum iTBS reached a level of 85% correct responses. When analysing decision time in the two-choice visual acuity task it turned out that tEE during DR also improved decision-time (shortening response latency) while verum iTBS did the opposite. Increased decision-time has been described as an epiphenomenon of amblyopia independent of visual acuity, indicating that also the development of other cortical regions than the visual cortex may be impaired [4]. Compared to standard cage housing tEE increased the expression of PV, BDNF and PKM in the visual cortex but additional iTBS rTMS weakened this effect, demonstrating that fast-spiking interneurons (PV+) and the factors regulating their activity are differently modulated by tEE and iTBS rTMS during the CP, allowing metaplastic processes.

This study has been supported by the Deutsche Forschungsgemeinschaft, DFG (FU 256/3-2, SFB 874, TP A4).

[1] Hensch TK (2005) *Nat Rev Neurosci* 6: 877-888.

[2] Funke K, Benali A (2011) *J. Physiol.* 589.18: 4423-4435.

[3] Mix A, Benali A, Eysel UT, Funke K (2010) *Eur. J. Neurosci.* 32: 1575-1586.

[4] Farcin F, Norcia AM (2011) *J. Vision* 11(14)6:1-10.

Combining wearable eye-tracking with 4p light-field measurements: towards controlling all bottom-up and top-down factors driving overt attention during real-world tasks

Josef Stoll, Mandana Sarey Khanie², Sandra Mende³, Marius t Hart¹, Marilynne Andersen³, Wolfgang Einhäuser^{1,4}

¹Fachbereich Physik, Philipps-Universität Marburg, AG Neurophysik, Karl-von-Frisch-Strasse 8a, 35043 Marburg, Germany

²Interdisciplinary Laboratory of Performance-Integrated Design (LIPID), ENAC, École Polytechnique Fédérale de Lausanne (EPFL), Switzerland

³Fraunhofer Institute for Solar Energysystems ISE, Freiburg i.Br., Germany

⁴Center for Interdisciplinary Research (ZiF), Universität Bielefeld

For improvement of office space design, we intend to capture the full (4p) light-field of an office space, while measuring gaze, head direction, body position, blink rate, and pupil size along with task performance and subjective well-being during a variety of office tasks. Besides the immediate application aspects this will allow for the first time to have full control over task *and* visual input in a fully unconstrained real-world setting. As a first step towards this goal, we combine the recording of eye- and head-movements at high sampling rate (221 Hz) using a comfortable head-mount gaze-tracking device ("EyeSeeCam"). This measurement is unobtrusive and allows performing experiments in a regular office environment.

In the study reported here, 52 participants performed office tasks that varied in the tools used (phone, computer, paper) as well as in their mental load – input, output, reflection and interaction – and were recorded under various experimentally controlled lighting conditions and outside views. We analyze gaze allocation during these tasks, with a particular emphasis on the distinct roles of eye and head, as well as on the effects of discomfort glare.

Each panel in the figure below depicts for a given task (columns: get text, think, answer, give opinion) and block (rows: screen, paper, phone) the resulting pooled distributions of eye-in-head orientation (upper left), head-in-room orientation (upper right) and gaze-in-room orientation (middle) as well as scatter-plots of individual means and standard deviations over horizontal against vertical angle coordinates (bottom; eye: red; head: green; gaze: blue).

We find that eye and head are fundamentally differently affected by view as well as depending on mental-activity and task conditions, unless participants' task is related to reading. Surprisingly, gaze allocation is not dominated by eye movements, but for some tasks head movements, which are not typically assessed in standard laboratory experiments of attention deployment, play a dominant role.

In sum, already this initial study highlights the importance of unconstrained settings when assessing the interaction of top-down and bottom-up factors driving attention in real-world scenarios.

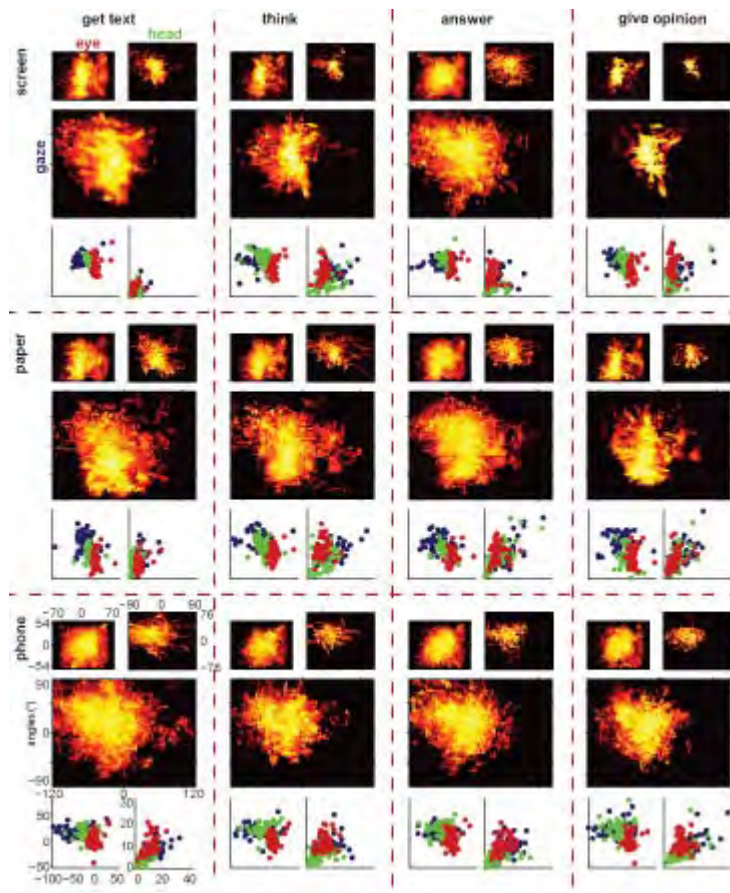

Population tuning and attentional modulation of human BOLD responses to spiral motion patterns

Sepideh Fazeli, Carsten Schmidt-Samoa², Peter Dechent², Stefan Treue¹

¹German Primate Center, Cognitive Neuroscience Lab, Goettingen, Germany

²Department of Cognitive Neurology, University Medicine Goettingen, Goettingen, Germany

Visual attention allocates sensory processing resources to more relevant information at the expense of processing inputs deemed less relevant. There have been numerous studies of such effects for the processing of visual motion information using linear motion patterns. Most of these studies have focused on the middle temporal (MT) area, known for its preponderance of direction-selective neurons. Very little is known about the influence of spatial visual attention to more complex motion patterns. In monkeys, neurons in the medial superior temporal (MST) area are tuned to so called 'spiral motion' stimuli and the homologue area in humans selectively responds to these complex motion patterns compared to linear motion. Here our main aim was to investigate the population tuning in MST to spiral motion patterns as well as the neural correlates of spatial attentional modulation of these responses in healthy human subjects using functional MRI to measure the blood-oxygen-level-dependent (BOLD) signal.

First we localized MT and MST using a localizer paradigm. We then determined the population tuning to spiral motion stimuli and its modulation by spatial attention. In the attention experiment subjects had to maintain their gaze on a central fixation point. Every trial started with the appearance of a fixation spot, followed by a central cue indicating the target location. Then two identical circular patches of spiral motion stimuli of 10° diameter were displayed for 3 sec, centered 10° to the right and the left. Each stimulus contained 0-3 speed changes. Subjects had to report the number of speed changes of the target stimulus. To determine population tuning in MT and MST, using a general linear model, the beta values for each voxel and each motion direction were estimated to extract the tuning curve in each voxel. These tuning curves were aligned to the preferred direction and averaged. Because this approach is prone to creating erroneous tuning through noise picking we applied a bootstrap analysis to rule out this effect. The modulation by spatial attention was determined by comparing the average BOLD response to expanding spiral stimuli when attention was on the contralateral vs. the ipsilateral stimulus.

We observed significant population tuning for spiral motion stimuli in MST in the majority of our subjects, but not in MT. This might indicate a higher specialization for spiral motion processing of human MST compared to MT, in line with reports from macaque visual cortex. We also observed a significant spatial attentional modulation that was of similar magnitude in MT and MST, indicating that attentional modulation may not always increase from one area to the next along the visual hierarchy.

Visual cortical development and ocular dominance plasticity in the absence of NKCC1

Katja Krempler, Knut Kirmse¹, Christian A. Hübner², Otto W. Witte¹, Knut Holthoff¹

¹Hans-Berger-Klinik für Neurologie, Universitätsklinikum Jena, Erlanger Allee 101, 07747 Jena, Germany

²Institut für Humangenetik, Universitätsklinikum Jena, Kollegiengasse 10, 07743 Jena, Germany

In immature neurons, GABA is excitatory due to a higher intracellular chloride concentration compared to mature neurons. In mouse brain, the switch from GABA being excitatory to being inhibitory is a consequence of a decrease in expression of the chloride intruder NKCC1 and an increase in expression of the chloride extruder KCC2 at around the end of the first postnatal week. The knock-out of NKCC1 has an impact on GABAergic depolarisation and maturation of the GABAergic system, but it remains unknown, whether the depolarizing action of GABA is necessary for the proper maturation of different brain regions. We tested, whether the absence of NKCC1 has an effect on the termination of the critical period for ocular dominance plasticity.

We used a conditional Emx1 Cre NKCC1 flox/flox knock-out mouse. The optokinetic reflex was quantified in behaving mice by means of a virtual-reality optomotor system and visual cortical maps were recorded by optical imaging of intrinsic signals). At first we performed control experiments to test, whether the retinotopic organisation in the visual cortex would be preserved and to monitor the development of the optokinetic reflex. Afterwards we performed monocular deprivations at age P25 and P55 and analyzed the potential shift in ocular dominance index in control and deprived animals.

Pairing-induced plasticity in the orientation preference map depends on the context of the local neural circuitry in ferret visual cortex

David Edward Whitney, Santosh Chandrasekaran^{1,3}, Juan Daniel Florez Weidinger⁴,
Seong-gi Kim⁵, Fred Wolf⁴, Justin Crowley^{1,2,3,6}

¹Dept. of Biol. Sci., ²Dept. of Biomed. Engin., Carnegie Mellon Univ., Pittsburgh, PA; ³Ctr. for the Neural Basis of Cognition, Pittsburgh, PA; ⁴Bernstein Ctr. for Computat. Neurosci. and MPI for Dynamics and Self-Organization, Göttingen, Germany; ⁵Dept. of Radiology, Univ. of Pittsburgh, Pittsburgh, PA; ⁶Fox Ctr. For Vision Restoration, Pittsburgh, PA

Fregnac et al. (1988) and Schuett et al. (2001) demonstrated that pairing a brief visual stimulus with electrical microstimulation of the cat visual cortex was capable of inducing shifts in the orientation preference of neurons. This result is intriguing, but limited in the spatial pattern with which one may stimulate the cortex using electrodes. For the next generation of these neural plasticity questions, Channelrhodopsin-2 (ChR2) provides the exciting possibilities of spatial patterned transfection and/or spatially patterned activation. Here we have extended previous results by pairing brief visual stimulation with direct activation of neural tissue in ferret visual cortex either with ChR2 optical stimulation (n = 14) or electrical stimulation (n = 14). Optical stimulation was achieved by selectively transfecting cells in an area of the visual cortex with a viral vector containing ChR2, which enabled transfected neural populations to be subsequently activated by blue light.

Using intrinsic signal optical imaging to measure functional responses of the visual cortex, we show that ferret orientation preference maps are capable of undergoing similar pairing-induced modifications to cat orientation preference maps. However, these pairing-induced modifications in functional maps tend to exhibit substantial variability. The variability between cases can be explained by the location of the stimulation site within the geometry of the physiological map. Specifically, we found a strong correlation between plastic change and the distance of the stimulation site(s) to local pinwheel centers ($r = 0.82$, $p < 0.05$). Single-cell measurements of orientation preference in neurons and astrocytes with two-photon calcium imaging confirm the pairing-induced shifts observed with intrinsic signal optical imaging. These changes in orientation tuning when averaged across animal experiments were local to the site of cortical activation and were significant within ~ 1.0 mm of the stimulation sites ($p < 0.05$). Additionally, pairing-induced modification through spatially patterned stimulation at two stimulation sites (rather than one), separated by the physical distance of an orientation hyper column depended more strongly on the stimulation site that was closer to a nearby pinwheel center ($r = 0.80$, $p < 0.05$) than the one further away ($r = -0.13$, $p > 0.05$). We hypothesize that local activation of neurons surrounding pinwheel centers may invoke neural circuits that are less likely to undergo pairing-induced modification, perhaps as a result of neural connectivity differences between pinwheel centers and other regions of the orientation map. Our data suggest that pairing-induced shifts in orientation preference occur in the context of the local circuitry of the visual cortex and are modulated by the geometric relationships of the cortex's functional architecture.

References:

- Fregnac Y, Shulz D, Thorpe S, Bienenstock E. A cellular analogue of visual cortical plasticity. *Nature*. 1988. 333, 367-370.
- Schuett S, Bonhoeffer T, Hübener M. Pairing-induced changes of orientation maps in cat visual cortex. *Neuron*. 2001; 32(2):325-37.

Is there a critical area size for the transition from interspersed to columnar V1 architecture?

Wolfgang Keil, Fred Wolf^{1,2}, Matthias Kaschube³, Michael Schnabel⁴, David M. Coppola⁵, Siegrid Loewel⁶, Len E. White⁷

¹MPI for Dynamics and Self-organization, Dept. for Nonlinear Dynamics, Am Fassberg 17, 37077 Goettingen, Germany

²BCCN, Goettingen, Germany

³Fac. of Computer Sci. and Mathematics, Frankfurt Inst. for Advanced Studies, Bernstein Focus for Neurotechnology, Goethe University,, Frankfurt am Main

⁴Departments of Applied Mathematics and Physics,, Physical Sciences–Oncology Center, Northwestern Inst. on Complex Systems, Northwestern University,, Evanston, IL, USA

⁵Dept. of Biol., Randolph-Macon Col., Ashland, VA, USA

⁶Sch. of Biol., Bernstein Focus for Neurotechnology, Göttingen Univ., Göttingen, Germany

⁷Dept. of Community and Family Med., Duke Inst. for Brain Sciences, Duke University,, Durham, NC, USA

Response characteristics of orientation-tuned neurons in the visual cortex appear to be similar in mammalian lineages widely separated in evolution. The spatial arrangement of preferences across the cortex, however, shows qualitative differences. While in primates and carnivores orientation preferences form orientation maps, in rodents they are spatially interspersed. Previously, we showed that orientation maps in several primate and carnivore species realize a single common design (Kaschube et al. Science 2010). This design can be explained by activity-dependent self-organization of large-scale neuronal circuits. The alternative Glires-typical interspersed organization can also form as a result of network self-organization when local inhibitory interactions dominate (Weidinger et al. SfN 2011). Available evidence indicates that both the interspersed organization and the occurrence of orientation columns are insensitive to V1 size (Keil et al. Science 2012). However, optimization principles for V1 architecture predict that V1 size could become a constraint in the spatial arrangement of orientation preferences; e.g., in carnivores and primates with V1 areas smaller than some minimal size. Here we examine whether optimization principles also predict an upper critical size (e.g., in Glires) above which a columnar design becomes preferable to an interspersed layout.

We examined models in which cortical organization is assumed to optimize a composite cost function that penalizes reductions in stimulus coverage and excessive wiring length. Since interspersed layouts exhibit near optimal coverage (Keil et al., SfN 2011) and wiring length cost decreases with area size, interspersed layouts form robust optima for small area sizes. With increasing V1 size, the relative advantage in coverage of an interspersed over a columnar organization decreases. Given that even in interspersed V1, neurons of similar orientation preference are preferentially connected; columnar layout is expected to reduce wiring cost relative to interspersed with the reduction in wiring cost per unit area of cortex essentially constant. Thus, under a wide range of conditions there exists a critical area size above which a columnar organization is more advantageous than an interspersed arrangement because the small gain in stimulus coverage offered by the interspersed design does not offset the accompanying wiring costs. The predicted transition from interspersed to columnar cortical design could be tested by examining preference layouts in large rodents, such as agouti or capybara.

Self-organisation of finite bandwidth orientation preference maps

Conor Dempsey, Wolfgang Keil^{1,2}, Dominik Heide^{1,2,4}, Fred Wolf^{1,2}

¹Max-Planck Institute for Dynamics and Self-Organization, Goettingen

²BCCN and BFNT, Goettingen University, Goettingen

³Columbia University, Graduate Program in Neurobiology and Behavior, New York

⁴Frankfurt Institute for Advanced Studies, BFNT Frankfurt, Goethe University, Frankfurt

In primates and carnivores the orientation preference of visual cortical neurons varies smoothly across the cortical surface creating an orientation preference map (OPM) exhibiting a typical spacing.

It has recently been shown that different species widely separated in terms of evolutionary descent exhibit OPMs with a strikingly similar structure. Further, it has been found that a symmetry-defined universality class of self-organization models with dominant long-range interactions can quantitatively explain this common structure.

Although reproducing various statistics of observed map layout, these models all lead to OPMs with an infinitesimal bandwidth, whereas experimentally measured OPMs show a finite bandwidth.

A key assumption in previously considered models is perfect homogeneity in the underlying visual cortical circuits. In particular a uniform typical spacing and a uniform rate of emergence of the OPM during development are assumed. Studies have shown that in cats column spacings vary widely across the surface of V1.

Here we present studies of models of the development of OPMs that generalize previously considered self-organization models by including such inhomogeneities. We explore two primary questions: firstly, can inhomogeneities account for the observed OPM structure without recourse to strong long-range cortical interactions; secondly, can cortical heterogeneity induce the self-organization of finite bandwidth OPMs that quantitatively match the biological pinwheel statistics.

We find that long-range interactions appear essential to account for the spatially quasi-periodic organization of OPMs and that this organization cannot be explained by inhomogeneities alone, and secondly that in certain regimes inhomogeneities in cortical circuitry can indeed induce the formation of aperiodic finite bandwidth OPMs with the correct pinwheel statistics.

Early visual processes involved in Vernier misperception under orientation masking : contributions of center-surround and spatial frequencies

Tzvetomir Tzvetanov

Institut fuer Informationsverarbeitung (TNT), Appelstrasse 9a, Leibniz Universtiaet Hannover; and 84 rue Paul Jozon, 77300 Fontainebleau, France

Vernier perception, i.e. the ability to see slight deviations from alignment of two abutting small line segments, was studied through multiple experimental methods, including orientation masking effects on hyperacuity thresholds of human subjects. Orientation masking is known to induce tilt misperceptions on a single line segment but only recently it was demonstrated to create Vernier misperceptions (Tzvetanov, Wirmer, Folta, *Vision Res.*, 2007, 47(12):1693-704). Their study clearly demonstrated orientation attraction and repulsion effects onto perceived Vernier lines orientation concurrent with Vernier alignment misperceptions, depending on the spatio-orientation configuration of the superimposed Vernier lines and orientation mask.

This work investigated the contributions onto misperceptions of small Vernier stimuli of center-surround masks and mask spatial frequency, and discusses the plausible mechanisms creating the misperception.

In a first experiment, center and surround masks were respectively a circular mask of grayscale cosine luminance wave (20 cpd, contrast 0.9) of diameter 18' and an annulus of identical luminance cosine of inner outer radius 13'/29', with predefined orientation tilts from Vernier lines of 0, 5, 10, 15, 20, 30, 50, 70, and 90 degrees. They were presented simultaneously with the abutting Vernier lines (each 8' length, 0.86' width, contrast 77.8 cd/m², bgd luminance 40 cd/m²) for 23 ms. Psychometric functions of Vernier alignment of the two lines were measured with the up-down staircase algorithm (Kaernbach, Perc. & Psych., 1991, 49:227-229) that varied the position of the bottom Vernier line (step size 0.24'). Subjects had to report the direction of perceived deviation of the bottom line, left or right, from alignment with the top line. Bayesian fits extracted the location of alignment perception for each condition for the 9 subjects. The results demonstrated a strong interaction effect while no main effects of both factors (2-way ANOVA; mask position $F(1,8)=0.29$, $p=0.60$; orientation $F(15,120)=0.99$, $p=0.47$; interaction $F(15,120)=4.49$, $p<0.01$), with center mask demonstrating orientation attraction (surround mask repulsion) onto perceived Vernier lines orientation.

The second experiment tested further the spatial frequency dependency of this observation, with the same procedure and stimuli, for mask spatial frequencies (SFs) of 20, 10 and 5 cpd and mask orientation tilts of 0, 10, 20, 50, and 90 degrees. Results for center and surround masks were analysed separately. Center mask demonstrated attraction effects only for 20 cpd SF at orientation tilts of 10 and 20 degrees and repulsion for 5 and 10 cpd SFs (confirmed by 2-way ANOVA with 4 subjects; SF $F(2,6)=64.14$, $p<0.01$; orientation $F(4,12)=1.16$, $p=0.38$; interaction $F(8,24)=8.52$, $p<0.01$). Surround mask showed no effects with a hint to small repulsion effect across all three SFs (2-way ANOVA; SF $F(2,6)=4.44$, $p=0.065$; orientation $F(4,12)=0.51$, $p=0.73$; interaction $F(8,24)=0.76$, $p=0.64$).

Simple local V1 inhibitory interactions are the mechanisms thought to create the tilt repulsion onto a single line segment, which accounts for the repulsion of Vernier lines by orientation mask. The current data localises the attraction effect only for Vernier lines and superimposed mask of high SF (20 cpd). Thus, only local neuronal populations sensitive to high SFs are involved in the orientation attraction

effects.

(TT was supported by DFG grant TZ69/1-1 during his stay at TNT (LUH)).

Systematic deviation of eye-movement direction from stimulus-direction during Optokinetic Nystagmus

Andre Kaminiarz, Kathrin Bartelheimer¹, Frank Bremmer¹

¹Philipps-Universität Marburg, Neurophysik, Karl-von-Frisch-Strasse 8a, 35043 Marburg, Germany

Optokinetic nystagmus (OKN) is a reflexive eye movement evoked by visual motion, which serves to stabilize the retinal image e.g. during head movements. It consists of two alternating phases: a slow phase in the direction of the stimulus motion and a fast phase opposite to the stimulus motion. It is well known that stimulus-direction affects eye-movement characteristics: for example the gain (eye-velocity/stimulus velocity) of the slow-phase component is different for vertical as compared to horizontal stimulus motion. During smooth pursuit eye movement direction is shifted away from the cardinal axes (horizontal and vertical) [1]. The few studies investigating the effect of stimulus direction on eye-movement direction demonstrate that during diagonal OKN eye movement direction is not in the direction of stimulus motion but is rather shifted towards the horizontal. In our current study we investigated the influence of stimulus direction on OKN slow-phase direction at high angular resolution to determine whether or not similar dependencies of eye movement direction on stimulus directions exist for voluntary (smooth pursuit) and reflexive (OKN) eye movements.

We recorded eye movements of eight human subjects performing Optokinetic Nystagmus while looking at Random Dot Patterns (RDPs) moving in 24 directions (0, 15, 30,..., 345°) using an infrared eye tracker (Eye Link II, SR Research). RDPs consisted of black dots on a white background and moved at 20°/s. Subjects were instructed to watch the stimulus attentively without intentionally following individual dots to assure they perform reflexive stare-nystagmus.

We observed pronounced OKN for all 24 stimulus directions. The mean frequency of fast phases, averaged across subjects and stimulus directions, was 4.4 Hz, demonstrating that we unequivocally evoked reflexive stare-nystagmus rather than voluntary look-nystagmus. All subjects showed a periodic deviation of eye-movement direction from stimulus-direction. Fourier-analysis revealed that the observed error pattern can be described as a superposition of three sine-functions with periods of 90, 180, and 360°. An error pattern with 90° period and the observed phase-shift of 0° can be considered a shift of eye movement direction away from both cardinal axes as described [1] for smooth pursuit. The error pattern with a period of 180° reflects a shift away from one axis. The analysis of phase-shifts revealed that for most subjects eye-movement direction was shifted away from one of the cardinal axes (horizontal or vertical). The 360° error-pattern is indicative of a shift in a single direction. Most subjects exhibited an upward shift of eye-movement-direction relative to stimulus-direction. In addition to eye-movement direction the gain and frequency of the OKN depended on stimulus direction. As before these dependencies can be described by sine-functions with periods of 90, 180, and 360 degrees. On average gain was higher for upward motion than for downward motion, while fast-phase frequency was higher for downward motion.

Our results indicate that like for voluntary eye-movements (pursuit) the directions of eye-movements systematically deviate from the direction of the stimulus also during reflexive eye-movements namely OKN.

[1] Krukowski AE, Stone LS (2005) Expansion of direction space around the cardinal axes revealed by smooth pursuit eye movements. *Neuron* 45:315-323.

PSD-95 lacking synapses in the visual cortex retain a high degree of AMPA receptor silence

Xiaojie Huang, Karl-Friedrich Schmidt², Bianka Goetze², Löwel Siegrid², Oliver Schlüter¹

¹European Neuroscience Institute Göttingen, Molecular Neurobiology, Grisebachstrasse 5, 37077 Göttingen, Germany

²Bernstein Focus Neurotechnology (BFNT) and Johann-Friedrich-Blumenbach Institut für Zoologie und Anthropologie, Georg-August-Universität Göttingen, Germany

PSD-95 belongs to the family of DLG-MAGUKs (membrane-associated guanylate kinases), which play an important role in organizing postsynaptic signaling and synaptic transmission in excitatory synapses. As shown in previous reports, the expression level of PSD-95 can control the basal AMPA receptor-mediated synaptic transmission in a positively correlated manner. Additionally, PSD-95 is involved in long-term synaptic plasticity. Knock-out (KO) of PSD-95 facilitates LTP induction and prevents LTD. To analyze the synaptic consequences of PSD-95 deletion on synaptic transmission and plasticity in the visual cortex, we performed electrophysiological analysis from acute slices of the PSD-95 KO mice at different developmental stages. In PSD-95 KO mice the AMPAR/NMDAR EPSC ratio was consistently decreased and the number of AMPAR silent synapses was increased compared to wild-type littermates. Unlike in control mice where the silent synapse level decreased during development, the percentage of silent synapses in PSD-95 KO mice retained at juvenile levels. These results provide a synaptic correlate for changes in PSD-95 KO mice in ocular dominance plasticity of the accompanying poster.

PSD-95 KO mice retain a juvenile ocular dominance plasticity into late adulthood

Bianka Goetze, Karl-Friedrich Schmidt¹, Xiaojie Huang², Oliver M. Schlüter², Siegrid Löwel¹

¹Bernstein Focus for Neurotechnology (BFNT) and School of Biology, Georg-August-Universität Göttingen/Germany

²Department of Molecular Neurobiology, European Neuroscience Institute, Göttingen/Germany

In the primary visual cortex (V1), monocular deprivation (MD) induces a shift in the ocular dominance (OD) of binocular neurons. In V1 of C57Bl/6J mice, this OD-plasticity is maximal at 4 weeks of age, declines in 2-3 months old animals ("adult" OD-plasticity) and is absent beyond postnatal day (P) 110¹. "Juvenile" and "adult" OD-plasticity have different effects on cortical activation: after MD in juveniles, deprived eye responses in V1 are reduced while in adults, the OD-shift is primarily mediated by an increase of open eye responses^{2,3}.

To test the role of the postsynaptic density protein PSD-95 in mouse OD-plasticity, we visualized V1-activity using intrinsic signal optical imaging in both PSD-95 KO-mice and their wild-type (WT) and heterozygous littermates (HZ) after 7 days of MD in animals from P70-388. Since PSD-95 KO-mice have been shown previously to have reduced orientation selectivity⁴ we additionally measured visual performance behaviorally.

Both visual acuity and contrast sensitivity were only slightly but significantly reduced in PSD-95 KO-mice compared to WT and HZ-mice. In addition, after MD, the increase of visual acuity through the open eye was similar in PSD-95 KO and WT/HZ-mice thus showing preserved sensory plasticity. In contrast, in PSD-95 KO-mice, juvenile OD-plasticity was found in animals of all ages: the OD-shift was i) as pronounced as previously only observed in 4-week-old C57Bl/6J mice and ii) mediated by a significant decrease of deprived eye responses in V1. To test if the prolonged plasticity of PSD-95 KO mice was due to reduced intracortical inhibition⁵ we treated mice with diazepam (i.p.) during 7 days of MD. Diazepam-treatment did neither reduce OD-plasticity nor sensory learning in PSD-95 KO mice compared to WT mice. Thus the increased OD-plasticity of PSD-95 KO-mice cannot be due to reduced intracortical inhibition in these animals. Since PSD-95 KO mice also retained a decreased AMPA/NMDA receptor ratio into adulthood⁶, we suggest that a high number of silent synapses promotes visual cortical plasticity in mice.

Funded by BMBF (1GQ0810).

¹Lehmann & Löwel (2008) PLoSOne 3:e3120.

²Hofer et al. (2006) Curr Opin Neurobiol. 16:451-9.

³Sato & Stryker (2008) JNS 28:10278-86.

⁴Fagiolini et al. (2003) PNAS 100:2854-9.

⁵Hensch et al. (1998) Science 282:1504-8.

⁶Huang et al. (2012) FENS Forum Abstr. 2012, 363.

In vivo identification of GABAergic and glutamatergic neurons at early developmental stage in mouse visual cortex

Michael Kummer, Knut Kirmse¹, Otto W. Witte¹, Knut Holthoff¹

¹Hans-Berger-Klinik für Neurologie, Universitätsklinikum Jena, Erlanger Allee 101, 07747 Jena, Germany

Recent studies suggest that early neuronal network activity is essential for a proper circuit development. However, it is not known to what extent the developing inhibitory system plays a role in the formation of intrinsic cortical activity. For *in vivo* identification of GABAergic and glutamatergic neurons we introduce a method that relies on the Emx1^{IRESc^{re}} recombinase driven expression of a red fluorescent protein in excitatory neurons and glia. Due to a pronounced neuropil staining, Emx1^{IRESc^{re}}-negative and Emx1^{IRESc^{re}}-positive neurons can be reliably differentiated based on negative and positive contrast, respectively. Immunohistochemical analyses confirmed that the entire population of GABAergic interneurons is represented by Emx1^{IRESc^{re}}-negative cells. A potential advantage is seen in the fact that Cre expression in Emx1^{IRESc^{re}} mice is already present at early embryonic stages. Using two photon calcium imaging, we are currently investigating the differential participation of GABAergic and glutamatergic neurons in network activity in primary visual cortex during the first two postnatal weeks.

Single spine synaptic inputs in mouse visual cortex in vivo

Diana Deca, Nathalie Rochefort¹, Arthur Konnerth¹

¹TUM , Institute of Neuroscience, Biedersteiner Str. 29, D-80802 Munich, Germany

Dendritic spines arise as small protrusions from the dendritic shaft of various types of neurons and receive inputs from excitatory axons. The individual functional properties and spatial arrangement of these excitatory synaptic inputs are critical for the processing of information by individual neurons. Previous work has identified visually-evoked local dendritic calcium signals ('hot spots'; Jia, Rochefort et al., Nature, 2010) in the mouse visual cortex. However, visually-evoked signaling on the level of dendritic spines, corresponding to individual afferent excitatory synapses, remained unexplored.

To analyze spine signaling during spontaneous and visually-evoked activity in vivo, we performed two photon imaging in combination with cell-attached recordings in layer 2/3 pyramidal neurons of the monocular region of the primary visual cortex in isoflurane anesthetized mice. We used the LOw power Temporal OverSampling (LOTOS) variant of two photon microscopy that was recently shown to facilitate single spine imaging in vivo (Chen et al., Nature, 2011). Layer 2/3 pyramidal neurons were first electroporated with a calcium dye and then targeted for cell-attached recordings. We recorded single spine calcium signals in parallel with the somatic spiking activity during spontaneous and drifting grating-evoked activity. Back-propagating spikes produced robust calcium transients throughout dendrites and spines. Importantly, we identified distinct single spine calcium signals in response to visual stimulation with drifting gratings.

Such active spines were widely distributed on basal and apical dendrites and drifting grating stimulation revealed both narrowly and widely tuned spines for the orientation of the gratings. These results provide strong support to the notion that the previously identified 'hot spots' represent single spine synaptic inputs.

Cortical plasticity in the face of congenitally altered input into V1

Jane Klemen, Michael B. Hoffmann¹, Christopher D. Chambers²

¹Otto-von-Guericke-University Magdeburg, Department of Ophthalmology, Visual Processing Lab, Leipzigerstr. 44, 39120 Magdeburg, Germany

²Cardiff University, School of Psychology and Cardiff University Brain Research Imaging Centre (CUBRIC), Park Place, Cardiff CF10 3AT, UK

Delineating the extent of cortical plasticity is fundamental to understanding human neurophysiology. Here we study the congenitally altered visual input into V1 present in albinism (Fig. 1a). In humans with albinism, on average the most central 8° of the temporal retina decussates atypically to the opposite hemisphere at the optic chiasm³. Consequently, the primary visual cortex is deprived of binocular input and instead receives input from both visual fields (VFs). The atypically routed ipsilateral and the typically routed contralateral representations are organized as retinotopic overlays, with VF positions that are mirror-symmetrical along the vertical meridian represented in close cortical vicinity⁴. This indicates that the visual information is not organised in ocular dominance, but instead in hemifield dominance columns. Normally, information held in the ocular dominance columns is integrated to yield stereo-vision. However, similar integration across the corresponding hemifield columns in albinism would result in a major sensory conflict. Cells receiving the integrated information would have dual receptive fields (dual VF cells, DVFC), arranged mirror-symmetrically along the central vertical meridian.

We hypothesized that if DVFCs exist, there should be an equivalent to inter-ocular transfer of adaptation in the albinotic visual system, resulting in inter-hemifield transfer of adaptation. In participants with albinism, adapting V1 neurons in one VF should, in the absence of plasticity, lead to an adaptation effect in the mirrored location in the opposite VF (Fig. 1c). Conversely, an absence of such interhemifield transfer (Fig. 1d) would indicate plasticity in the primary visual cortex.

The tilt after-effect (TAE) adaptation paradigm¹ (Fig. 1b) was employed to study interhemifield transfer in 6 participants with ocular or oculocutaneous albinism and 6 control participants with normal or corrected-to-normal vision.

The TAE differed significantly by probe location (albinism: $F_{3,15} = 22.2$, $p < .0001$; control: $F_{3,15} = 23.0$, $p < .0001$, Fig. 1e&f) with significant TAEs observed only at the adaptor location (albinism: $p_{.013} < .001$; control: $p_{.013} = .002$) and at the ipsilateral control location (albinism: $p_{.017} = .011$; control: $p_{.017} = .013$). The TAE at the adaptor location was significantly larger than that at its neighbouring ipsilateral control location (albinism: $p_{.008} = .002$; control: $p_{.013} = .006$). At the two locations contralateral to the adaptor, no TAE was observed (albinism & control: all $p_{.025} > .075$).

The current study demonstrates the absence of inter-hemifield transfer and thus the absence of DVFCs in albinism. It thus underlines that in primates with albinism the conservative geniculostriate projection is complemented by intracortical plasticity to make the altered visual representation available for perception. This contrasts with patterns observed in some non-primate animals with albinism: either a conservative geniculostriate projection combined with an intracortical suppression of the ipsilateral hemifield representation, or an altered geniculostriate projection is observed².

References

- 1 Gibson & Radner. J Exp Psychol, 20(5): 453-467, 1937.
- 2 Guillery. Trends Neurosci, 9(8): 364-367, 1986.
- 3 Hoffmann, Lorenz, Morland, & Schmidtborn. Invest Ophth Vis Sci, 46(10): 3892-3898, 2005.
- 4 Hoffmann, Tolhurst, Moore, & Morland. J Neurosci, 23(26): 8921-8930, 2003.

Supported by the Deutsche Forschungsgemeinschaft (DFG HO-2012/10-1)

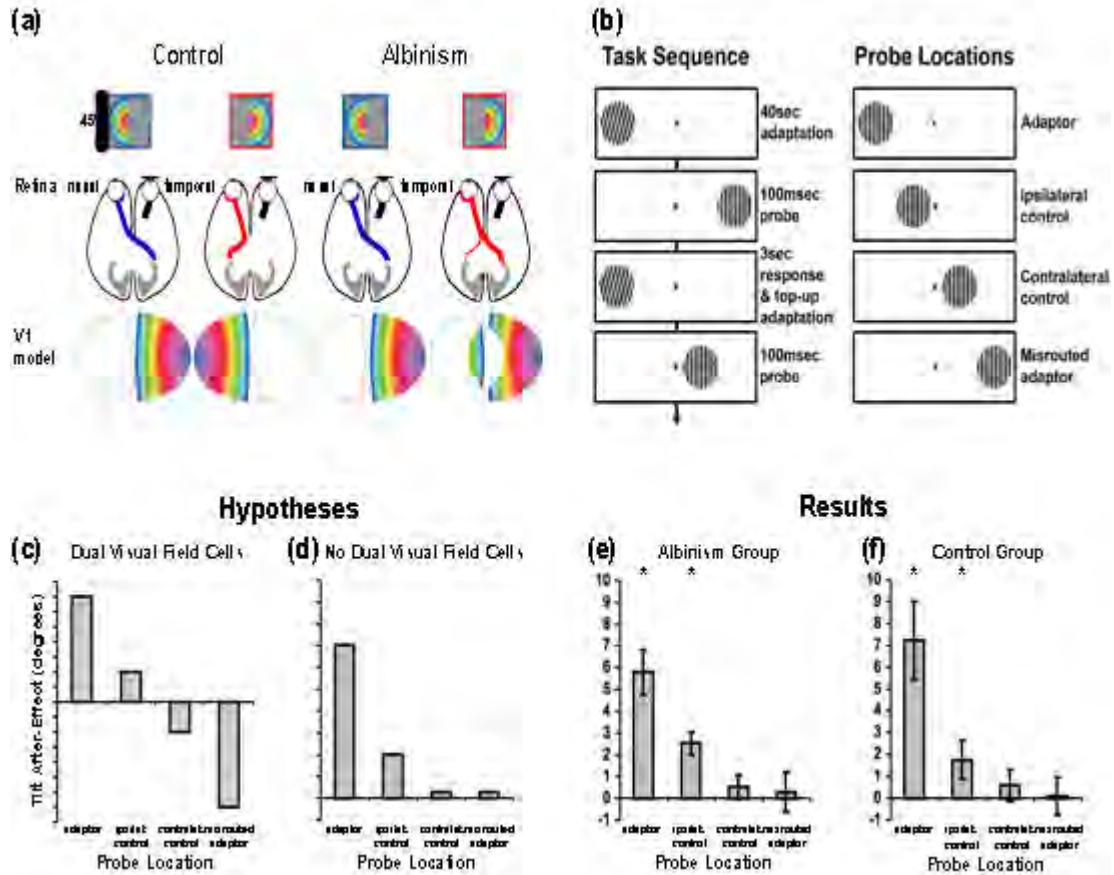

Cortical plasticity in the human visual cortex - Effect of chiasma opticum abnormalities on ventral visual areas

Falko R Kaule, Barbara Wolynski¹, Anil Kumar², Irene Gottlob², Jörg Stadler³, Oliver Speck⁴, Martin Kanowski⁵, Synke Meltendorf¹, Michael B Hoffmann^{1,6}

¹Department of Ophthalmology, Otto-von-Guericke-University, Visual Processing Laboratory, Leipziger Straße 36, 39120 Magdeburg, Germany

²Ophthalmology Group, University of Leicester, Leicester Royal Infirmary, Robert Kilpatrick Clinical Sciences Building, Leicester LE2 7LX, United Kingdom

³Leibniz Institute for Neurobiology, Brennekestraße 6, 39118 Magdeburg, Germany

⁴Department Biomedical Magnetic Resonance, Institute for Experimental Physics, Otto-von-Guericke-University Magdeburg, Leipziger Str. 44, 39120 Magdeburg, Germany

⁵Department of Neurology, Otto-von-Guericke-University, Leipziger Str. 44, 39120 Magdeburg, Germany

⁶Center for Behavioral Brain Sciences Magdeburg, Germany

Purpose: Congenital visual pathway abnormalities allow unique insights into plasticity and development of the human visual pathways. Normally the nasal retina projects to the contralateral hemisphere and the temporal retina to the ipsilateral hemisphere. Consequently, each hemisphere receives input from the contralateral visual hemifield. Remarkably, sizable deviations from this projection scheme occur in albinism, where the temporal retina projects to the contralateral hemisphere, and in achiasmia, where the nasal retina projects to the ipsilateral hemisphere. As a consequence, in albinism and achiasmia each hemisphere receives input from both visual hemifield [1,2]. The impact of this altered representation on visual perception in these subjects is relatively small, primarily reduced stereo vision. We investigated the impact of misrouted optic nerves on cortical visual field maps in the ventral processing stream to detail how the abnormal representation is integrated into visual processing.

Methods: We applied retinotopic mapping based on functional magnetic resonance imaging (fMRI) at a magnetic field strength of 3 or 7 Tesla (voxel size: 2.53 mm³; TR: 2.4 s; volumes per scan: 105) in eleven subjects (5 albinotic, 1 achiasmatic and 5 control subjects). During the scans the subjects monocularly viewed a contrast-inverting section of a circular checkerboard-stimulus that moved through either the left or right visual hemifield as an expanding ring for eccentricity mapping and as a rotating wedge for polar-angle mapping. Each condition, comprising seven 36 s – cycles, was presented twice.

Results: Similar patterns of the organisation of the visual cortex were observed in albinism and achiasmia. The normal contralateral and abnormal ipsilateral representation of the visual hemifields were organized retinotopically and superimposed as mirror-symmetrical overlays in each of the early visual areas examined, i.e., V1, V2, V3, V4, and also in higher tier areas of the ventral processing stream (parahippocampal cortex (PHC) 1 & 2, ventral-occipital area (VO) 1 & 2).

Conclusion: The retinotopic overlay of opposing visual hemifields in V1 observed in albinism and achiasmia indicates, in accordance with previous reports [1,2], conservative geniculo-striate projections despite substantial misrouting of the optic nerves. Further, the organisation pattern demonstrated for V1, i.e. retinotopic overlay, is also evident in all visual areas examined, including higher ventral visual areas VO1 & 2, and PHC1 & 2. Consequently, the abnormal representation is propagated through large expanses of visual cortex without rectification. This highlights largely unaltered cortico-cortical connections despite substantially altered input to the visual cortex. These features were observed consistently in subjects with different congenital chiasmatic abnormalities, i.e. albinism and achiasmia, which indicates that they reflect a general developmental mechanism in the human visual system. Remarkably, this largely conservative organisation scheme leaves sufficient scope for neural plasticity to make the abnormal input available for visual perception.

Supported by the Deutsche Forschungsgemeinschaft (DFG HO-2012/10-1) and the federal state of Saxony-Anhalt (CBBS)

[1] Hoffmann MB et al. (2003) Organization of the visual cortex in human albinism. *J. Neurosci.* 23:8921-30

[2] Hoffmann MB et al. (2012) Plasticity and stability of the visual system in human achiasma. *Neuron* 75:393-401

Ultra-high spatial resolution fMRI of the human visual cortex at 7 Tesla magnetic field strength

Juan Lei, Renat Yakupov², Falko R. Kaule^{1,3}, Frank Godenschweger², Oliver Speck²,
Michael B. Hoffmann^{1,3}

¹Otto-von-Guericke-University, Germany, Department Ophthalmology, Leipziger Str.44, 39120 Magdeburg, Germany

²Otto-von-Guericke-University, Germany, Department Biomedical Magnetic Resonance, Institute for Experimental Physics, Leipziger Str.44, 39120 Magdeburg, Germany

³Center for Behavioral Brain Sciences, Magdeburg, Germany

Purpose: Functional magnetic resonance imaging (fMRI) at ultra-high magnetic field strengths, e.g., 7 Tesla, is a promising candidate for high spatial resolution analysis of cortical activity. Previous studies used fMRI at 7 Tesla with a spatial resolution of down to 1.1^3 mm^3 and obtained sizable reproducible responses in the visual cortex within a few minutes of measurement time [1, 2]. However, reliable fMRI at submillimetre voxel dimensions, which would be of particular value for the identification of the fine-structure e.g. of the human visual cortex, is still debatable. The purpose of this study was to assess the quality of fMRI data acquired at a magnetic field strength of 7 Tesla in the visual cortex using ultra-high spatial resolutions, e.g., 0.8^3 mm^3 and 0.65^3 mm^3 .

Methods: Firstly, an assessment of high spatial resolution fMRI data for full visual field stimulation of a contrast-reversing circular checkerboard was conducted for four subjects. For this purpose fMRI data (88 volumes at a sampling interval of 3 s; T2*-weighted gradient echo EPI) of the visual cortex (V1-V3) were obtained at 1.1^3 mm^3 , 0.8^3 mm^3 , and 0.65^3 mm^3 voxel size using a block-design stimulation paradigm. Secondly, an assessment of fMRI-based retinotopic mapping [1] at high spatial resolution obtained to stimulation with contracting rings for eccentricity mapping and with counter-clockwise rotating sectors for polar angle mapping was conducted for two subjects. These retinotopic mapping data (110 volumes at a sampling interval of 2.4 s) of the visual cortex (V1-V3) were obtained for 0.8^3 mm^3 and 0.65^3 mm^3 voxel size, and compared to data for the conventional resolution of 2.0^3 mm^3 . For both experiments the data were analyzed with respect to amplitude, coherence, and phase of the Blood-Oxygen-Level-Dependent (BOLD) response at stimulation frequency using VistaSoft (Dpt. Psychology, Stanford, USA).

Results: In both experiments robust responses were obtained within 4.4 minutes of scanning at all spatial resolutions used. Further, reproducible and plausible retinotopic maps were obtained for the different resolutions applied. The results of the study thus revealed that fMRI with 0.65 mm isotropic voxels allowed the reliable measurement of complex spatio-temporal patterns of BOLD responses in the visual cortex.

Conclusion: fMRI of the human visual cortex can be performed at submillimetre resolution using 0.65 mm isotropic voxels at a magnetic field strength of 7 Tesla, which opens various options of an advanced analysis of structure and function of the human visual cortex.

[1] Hoffmann MB, Stadler J, Kanowski M, Speck O (2009) Retinotopic mapping of the human visual cortex at a magnetic field strength of 7 Tesla. *Clinical Neurophysiology* 120:108-16

[2] Swisher JD, Sexton, JA, Gatenby JC, Gore JC, Tong F (2012) Multishot versus single-shot pulse sequences in very high field fMRI: a comparison using retinotopic mapping. *PLoS One*, 7(4), e34626.

Supported by the Deutsche Forschungsgemeinschaft (DFG HO-2012/10-1) the federal state of Saxony-Anhalt (CBBS)

Neuronal nonlinearity explains differences in visual spatial resolution between darks and lights

Jens Kremkow, Jianzhong Jin¹, Stanley Jose Komban¹, Yushi Wang¹, Reza Lashgari¹, Michael Jansen¹, Xiaobing Li¹, Jose-Manuel Alonso¹

¹State University of New York (SUNY-Optometry), Department of Biological Sciences, 33 West 42nd St, 10036 New York, USA

Astronomers and physicists noticed centuries ago that visual spatial resolution is higher for dark than light stimuli; however, the neuronal mechanisms for this perceptual asymmetry remained unknown. Here we investigated the neuronal mechanisms underlying this phenomenon by recording extracellularly single ON-center and OFF-center cells in the visual thalamus (LGN) and multi-unit activity in the visual cortex (V1) of cat. We measured the spatial resolution on the neuronal level by mapping receptive fields with light and dark sparse noise and calculating the size of the receptive fields. Spatial resolution can be inferred in this way because the receptive field size is correlated with the spatial frequency tuning: small receptive fields encode for higher spatial frequency tuning than large receptive fields.

We found that receptive fields of ON-center cells are larger than receptive fields of OFF-center cells ($ON_{size}/OFF_{size} = 1.3$, $p < 0.001$) when mapped on binary backgrounds (light targets on dark backgrounds and dark targets on light backgrounds). Smaller but still highly significant differences were found in V1 multi-unit activity ($ON_{size}/OFF_{size} = 1.1$, $p < 0.001$). Strikingly, these differences disappeared in the LGN when receptive fields were mapped on gray backgrounds ($ON_{size}/OFF_{size} = 1$, $p = 0.9$), and even reverse in V1 neurons, as preliminary data suggests ($ON_{size}/OFF_{size} = 0.8$, $p < 0.001$). Thus, we show that the difference in spatial resolution reported perceptually can also be found on the neuronal level in the LGN and V1. However, the difference in spatial resolution is not constant and changes dynamically with the background luminance.

What could be the underlying mechanisms of this dynamic change in spatial resolution for light and dark stimuli? We anticipated that a nonlinear encoding of luminance increments and decrements could explain these differences. To test this prediction we characterized the neuronal transfer-functions to light and dark stimuli by presenting a small spot of varying luminance on both binary and gray backgrounds.

We found that OFF-center cells increase their responses roughly linearly with luminance contrast, independently of the background luminance (OFF-center cells: mean I_{50} light background = 0.36, mean I_{50} gray background = 0.33, $p = 0.3$). In marked contrast, ON-center cells saturate their responses with small increases in luminance and require bright backgrounds to approach the linearity of the OFF-center cells (ON-center cells: mean I_{50} dark background = 0.06, mean I_{50} gray background = 0.27, $p < 0.001$). V1 neurons showed qualitative the same nonlinear encoding of lights and darks (ON: mean I_{50} dark background = 0.11, mean I_{50} gray background = 0.37, $p < 0.001$; OFF: mean I_{50} light background = 0.49, mean I_{50} gray background = 0.47, $p = 0.2$). Although the integration of lights becomes more linear on gray backgrounds, a pairwise comparison in V1 neurons showed that responses to lights saturate stronger than responses to darks ($p < 0.001$). This nonlinearity can explain the larger receptive fields of ON channel cells: receptive fields are more blurred in the ON than OFF channel especially on dark backgrounds explaining the difference in receptive field sizes.

Preliminary data from local field potential recordings in awake primate support the findings of nonlinear encoding of darks and lights, suggesting a general principle of how ON and OFF channel process visual information.

Zebrafish *bel* mutant as a model for infantile nystagmus syndrome (INS): Pharmacologic interactions with the ocular motor system

Maresa Afthinos, Ying-Yu Huang¹, Dominik Straumann¹

¹University Hospital Zurich, Dept. of Neurology, Frauenklinikstrasse 26, 8091 Zürich, Switzerland

Infantile nystagmus syndrome (INS) is a disorder characterized by involuntary conjugate and horizontal oscillations of the eyes. The prevalence in newborns is 0.1-0.6%, and it is present at birth or shortly after. Although the brain can adapt partly to the constantly oscillating eyes, INS is associated with substantial visual impairments that often lead to reduced occupational and social functioning.

The study of INS has been largely confined to humans and few other higher vertebrates. The limitations inherent to human-based research have made it difficult to determine the origin and the underlying neural mechanisms of INS. Recently, it has been discovered that zebrafish *belladonna* (*bel*) mutants display spontaneous ocular oscillations that closely resemble INS in humans. Being relatively simple and inexpensive to maintain and highly accessible, the zebrafish *bel* mutant is a very promising animal model for INS.

So far, there are no specific pharmacological treatments for INS; most publications on INS-ameliorating drugs in humans are based only on case reports. In this study, we examined whether the reported drugs can also reduce spontaneous eye oscillations in zebrafish and how they affect the ocular motor stability under different visual conditions.

In a first step, we studied the effect of the most commonly used anti-INS drugs: 4-aminopyridine, gabapentin and memantine. The eye movements of 4-7 days old zebrafish larvae were recorded with a custom-built setup, and processed and analyzed with custom-built software. The visual surround can be changed to assess different types of eye movements: dark background (spontaneous saccades and eye), stationary structured background (spontaneous saccades with subsequent gaze holding, spontaneous nystagmus), and moving structured background (optokinetic response). Each larva was recorded before and after drug administration. Wild type larvae and *bel* siblings (no homozygous mutation) were used as controls.

In human patients, both gabapentin and memantine can improve visual acuity and reduce different types of nystagmus including INS, although the effect varies even among patients with the same type of nystagmus. Preliminary data in fish showed that gabapentin and memantine can dampen spontaneous nystagmus (both in frequency and amplitude) in zebrafish *bel* mutants.

4-aminopyridine has been shown to help patients with downbeat (vertical) nystagmus. The first few zebrafish experiments with this compound indicate a more complex effect on eye movements. The drug slightly reduced the amplitude and increases the frequency of spontaneous nystagmus, but also generated superimposed fast oscillations of the eyes during the optokinetic response. These oscillations persisted in the dark or when exposed to a stationary structured background. As a next step, we need to confirm our first findings with different drug dosages and at different developmental stages.

With further experiments, we expect that we will not only be able to validate the effect of the existing INS-ameliorating drugs, but also perform a candidate neurological drug screening in order to identify potential new drug treatments for INS. Our ultimate goal is to uncover the so far unknown pathological mechanisms of INS in humans and to develop new diagnostic methods and treatments for INS patients.

Supported by Swiss National Science Foundation; Center of Integrative Human Physiology, University of

Zurich; Koetser Foundation for Brain Research.

Top-down attention modulates post-saccadic remapping in macaque MT

Tao Yao, Stefan Treue¹, Suresh KRISHNA¹

¹German Primate Center, Cognitive Neuroscience Laboratory, Kellnerweg 4(AKN), 37077 Goettingen, Germany

Perisaccadic remapping is a phenomenon where neurons respond to stimuli in their future, post-saccadic receptive fields (RFs). It may help keep track of locations in the visual field across saccades and facilitate rapid sequential eye-movements as well as visual stability across saccades. It comes in two forms: a) anticipatory remapping occurs pre-saccadically, or post-saccadically with a latency shorter than the usual visual latency and b) the post-saccadic memory trace, which is a response to a stimulus in the future RF that is turned off before saccade onset. Both kinds of remapping have been observed in putative attentional/oculomotor control areas (LIP, FEF, SC) and also in visual areas like V2, V3, V3A, etc. But little is known about how remapping impacts visual motion processing: the only previous report from area MT, an important motion processing area in the visual dorsal pathway, showed the absence of anticipatory remapping (Ong & Bisley, 2011, *Journal of Neuroscience*). Our first aim was to examine whether MT neurons show a post-saccadic memory trace, even though they do not show anticipatory remapping. Further, even though top-down attention is known to modulate neuronal responses in many visual areas including MT, its effects on remapping have never been studied. Our second aim was therefore to test whether top-down attention modulated the memory trace in MT, if we indeed found one. We recorded 51 MT neurons in a monkey that was trained to make a saccade while performing an attentionally demanding motion-task on one of two moving random dot patterns (RDPs) in the visual field. Either the attended or the unattended RDP appeared in the post-saccadic receptive field of the neurons on every trial. On half the trials, the moving patches disappeared just before the saccade so that no stimulus ever appeared in the neurons' current receptive field. On another pure saccade condition, no RDPs were presented on the screen and the monkey only needed to make a saccade when the fixation point jumped from one location to another. We find a clear memory trace for the cued stimulus (50 % enhancement compared to pure saccade, where there is no stimulus in the future RF, $p < 0.0001$, paired-t test) in the MT population we recorded from. Further, attention strongly modulates this memory-trace: the memory trace for the cued stimulus is 36 % stronger than for the uncued stimulus ($p < 0.0001$, paired-t test). Our results further clarify the nature of perisaccadic representation of visual stimuli in the dorsal stream and demonstrate a significant role for top-down attention in modulating this representation.

Brightness and color discrimination in the Mongolian gerbil

Kay Thurley, Josephine Henke¹, Christian Garbers¹, Christian Leibold^{1,2}, Thomas Wachtler^{1,2}

¹Neurobiology, Department Biology II, Ludwig-Maximilians-University Munich

²Bernstein Center for Computational Neuroscience, Munich

The retina of the Mongolian gerbil (*Meriones unguiculatus*) contains two types of cone photoreceptors that are maximally sensitive at wavelengths of 360 nm and 493 nm, respectively, and one rod photoreceptor with a maximal sensitivity at 501 nm (Jacobs & Deegan 1994, *Vision Res* 34: 1433). It is the only known mammal that has a rod receptor with a peak sensitivity at longer wavelength than all the cone receptors. Gerbils therefore exhibit photopic vision with a peak sensitivity at shorter wavelength than that of the scotopic mechanism (Jacobs & Neitz 1989, *Experientia* 45: 317). However, so far little is known about visual processing in these animals.

Since gerbils can be trained to visual discrimination tasks, their visual capabilities can be analyzed in behavioral experiments. We used a virtual reality (VR) setup with a spherical treadmill that is surrounded by a toroidal screen onto which a virtual scene is projected. The VR setup offers a highly controlled environment for sensory testing. To test visual performance we used a two-alternative forced choice task. Visual targets were presented at the ends of the arms of a virtual y-maze. The animal had to run to the end of one of the arms and received a reward if the decision was correct. First we trained gerbils to discriminate between bright and dark stimuli. In a second set of experiments the gerbils had to compare the brightness of a central patch relative to its local background. Despite differences in the absolute luminance of the stimuli the animals chose those with the correct relative brightness. The threshold for relative brightness discrimination was below a Weber contrast of 0.1. These results are an indication of brightness constancy in the Mongolian gerbil. In a final set of experiments, we used stimuli that differed in spectral composition to investigate color discrimination. Again, the gerbils could discriminate stimuli with differences in cone excitations corresponding to a Weber contrast of 0.1.

Visualization of transcranial magnetic stimulation effects by voltage-sensitive dye imaging

Vladislav Kozyrev, Ulf T. Eysel², Dirk Jancke¹

¹Real-time Optical Imaging Group, Institut für Neuroinformatik, Ruhr-Universität Bochum, Germany

²Experimental Neurophysiology Dept., Medizinische Fakultät, Ruhr-Universität Bochum, Germany

Transcranial magnetic stimulation (TMS) induces electrical currents in the brain which stimulate the neural tissue. Despite the widespread use of the TMS, the neuronal mechanisms of TMS-induced activity are not well understood. Here we introduce a novel method of imaging TMS-evoked activity *in-vivo* in a cortical patch (~0.5 cm²) stained by a voltage-sensitive dye (VSD). Molecules of the VSD, presumably bound to neuronal membranes, transduce changes of the membrane potential into an optical signal. This signal, originating from large neuronal populations, is recorded by a video camera at high temporal (5 ms) and spatial (~50µm) resolution, allowing the dynamics and spatial spread of a TMS pulse to be measured. We used VSD imaging to monitor activity induced in primary visual cortex of anesthetized adult cats by single and repetitive (rTMS) pulses as well as alteration of neuronal function during and beyond the stimulation period. We observed a gradual build-up of ongoing cortical activity in response to each magnetic pulse within 10 Hz rTMS trains. We hypothesize that this indicates the evolution of an excitatory cortical state that may facilitate plastic reorganization of orientation map layout. We compared the dynamics of evoked responses to oriented gratings before and after a protocol of 10 Hz rTMS trains presented during 20-30 min. First, a transient suppression within the rise time of responses, typically referred to as deceleration-acceleration notch in VSD recordings (see Sharon & Grinvald, 2002), was significantly diminished indicating weakened inhibition. Second, responses to non-preferred orientations increased while modulation depth, as a global measure of orientation selectivity, was unaltered. Third, preliminary data showed shifts in the balance of represented orientations within the map. Altogether, these findings imply that TMS-induced cortical reorganization processes are accompanied by increased overall plateau levels of nonspecific activity and reduced intracortical inhibition. Our results demonstrate that combining TMS with VSD imaging allows artifact-free visualization of TMS-induced activity in the animal brain and provides a powerful method to study plasticity of the functional cortical architecture. The project is funded by the Deutsche Forschungsgemeinschaft, SFB 874.

Poster Topic

T17: Auditory Mechanoreceptors, Vestibular, Cochlea, Lateral Line and Active Sensing

- T17-1A** OAE-residuals generated with complex sound stimuli in the short-tailed fruit bat *Carollia perspicillata* (Phyllostomidae)
Désirée Schlenther, Manfred Kössl
- T17-2A** Ducky mice with a mutant $\alpha_2\delta_2$ Ca^{2+} channel subunit: a new model for sensorineural hearing impairment
Barbara Fell, Niels Brandt, Gerald J. Obermair, Julia Dlugaiczyk, Dietmar Hecker, Bernhard Schick, Jutta Engel
- T17-3A** Mechanical two-tone-distortions in the tympanum motion of locusts
Doreen Möckel, Manfred Kössl, Manuela Nowotny
- T17-4A** Optoacoustic stimulation of single cells
Alexander Rettenmaier, Thomas Lenarz, Günter Reuter
- T17-5A** Hearing in *Drosophila* requires visual rhodopsins
David Piepenbrock, Pingkalai R. Senthilan, Martin C. Göpfert
- T17-6A** Mechanical Tuning of the High-Frequency Hearing Organ in Bushcrickets
Jennifer Hummel, Manfred Kössl, Manuela Nowotny
- T17-1B** A Viscoelastic Model of Adaptation in Mammalian Auditory-Nerve Fibers
Adam Peterson, Peter Heil
- T17-2B** Determination of dynamic vesicle pools in inner hair cell ribbon synapses
Carolin Wichmann, Elisabeth Auge, Ellen Reisinger, Tobias Moser
- T17-3B** Temporal integration in the auditory pathway of the grasshopper
Sarah Wirtsohn, Bernhard Ronacher
- T17-4B** Auditory processing in a bush-cricket interneuron
Timothy George Bayley, Berthold Hedwig
- T17-5B** Auditory Characterisation of $\text{Ca}_v2.3^{-/-}$ mice using Auditory Brainstem Responses
Marco Weiergräber, Anna Papazoglou, Ralf Müller, Christina Henseler, Karl Broich, Roger Miller, Andreas Lundt

- T17-6B** Does stress alter hearing through direct effects in the cochlea?
Mirko Jaumann, Wibke Singer, Sze Chim Lee, Kamyar Kasini, Lukas Rüttiger, Marlies Knipper
- T17-1C** Three dimensional acoustic orientation in insects
Nanina Tron, Liesa-Kristin Beuter, Reinhard Lakes-Harlan
- T17-2C** Vibration perception in Orthoptera
Reinhard Lakes-Harlan, Philipp Keil, Robert Kügler, Heusler Jan, Strauss Johannes
- T17-3C** Functional categorization of abducens motoneurons as the basis for appropriate dynamic tuning of vestibulo-ocular responses in *Xenopus laevis*.
Haike Dietrich, Hans Straka
- T17-4C** Ontogenetic plasticity of linear vestibulo-ocular reflexes in *Xenopus laevis*
Francisco Branoner, Hans Straka
- T17-5C** Multimodal map formation of two sensory modalities without visual teacher: a dynamical model for the blind mexican cavefish *Astyanax Mexicanus*.
Matthias Krippner, Julie Goulet, J. Leo van Hemmen
- T17-1D** Spike-rate resonances in small neuronal networks: from the cricket auditory system to general models
Florian Rau, Jan Clemens, Viktor Naumov, Wei Wu, R. Matthias Hennig, Susanne Schreiber
- T17-2D** Analysis of a mouse model with a missense mutation in otoferlin
Ellen Reisinger, Hanan Al-Moyed, Tina Pangrsic, Tobias Moser, Nicola Strenzke
- T17-3D** Medullary lateral line units of the common Rudd, *Scardinius erythrophthalmus*, are sensitive to object position
Evelyn Dylida, Adrian Klein, Horst Bleckmann
- T17-4D** The influence of CaBP2 on the biophysical properties of Inner Hair Cell $\text{Ca}_v1.3 \text{ Ca}^{2+}$ channels
Maria Magdalena Picher, Isabelle Schrauwen, Sarah Helfmann, Akira Inagaki, Friederike Predoehl, Mohammad Amin Tabatabaiefar, Manou Sommen, Celia Zazo Seco, Jaap Oostrik, Hannie Kremer, Annelies Dheedene, Charlotte Claes, Erik Fransen, Morteza Hashemzadeh Chaleshtori, Paul Coucke, Amy Lee, Guy Van Camp, Tobias Moser
- T17-5D** Discreet long-term monitoring of electric fish behavior
Jörg Henninger, Rüdiger Krahe, Jan Benda

OAE-residuals generated with complex sound stimuli in the short-tailed fruit bat *Carollia perspicillata* (Phyllostomidae)

Désirée Schlenther, Manfred Kössl¹

¹Institut für Zellbiologie und Neurowissenschaft, Neurobiologie und Biosensorik, Max-von-Laue-Str. 13, 60438 Frankfurt am Main, Germany

When measuring otoacoustic emissions (OAEs) to investigate inner ear mechanics often simple pure tone stimuli are used. As an indicator of non-linear mechanical sound processing of the outer hair cells, the distortion-product OAEs (DPOAEs) are evoked by simultaneous stimulation of the ear with two pure tones and can be measured in the outer ear canal with a sensitive microphone. The DPOAEs arise at certain frequencies which are mathematically related to the chosen stimulation frequencies. The present study investigates the generation of cochlear distortions while using more natural complex sounds as stimuli, such as animals' vocalizations (communication and echolocation calls). To be able to measure complex-sound DPOAE using behaviourally relevant stimuli, a residual measurement paradigm was applied.

The OAE-residuals are recorded using three time windows: (1) An acoustical stimulus is applied through a loudspeaker. (2) The same stimulus is applied at a higher sound level through a second loudspeaker. (3) The same stimuli as in (1) and (2) are applied simultaneously through both loudspeakers. The OAE-residual is calculated from the measured signals of all three time windows as follows: $R = \text{signal 3} - (\text{signal 1} + \text{signal 2})$.

To assess high frequency hearing mechanisms we used the echolocating bat species *Carollia perspicillata*. First of all, we measured DPOAEs and OAE-residuals, both under pure tone stimulation, proving the consistency of the emissions sensitivity and the comparability of the methods. Subsequently, the measured OAE-residuals, using prerecorded communication and echolocation calls of the bats, are recorded with the aim to reveal how the cochlea of *Carollia perspicillata* changes incoming natural sounds due to nonlinear mechanical processing. The OAE residuals should also be subject to sensory transduction by inner hair cells and then feed into the ascending auditory pathway and contribute to hearing sensation.

Supported by the DFG KO987/11-1

Ducky mice with a mutant $\alpha_2\delta_2$ Ca^{2+} channel subunit: a new model for sensorineural hearing impairment

Barbara Fell, Niels Brandt¹, Gerald J. Obermair³, Julia Dlugaiczyk², Dietmar Hecker², Bernhard Schick², Jutta Engel¹

¹Saarland University, Department of Biophysics, Homburg, Germany

²Saarland University, Department of Otolaryngology, Homburg, Germany

³Innsbruck Medical University, Department of Physiology and Medical Physics, Innsbruck, Austria

Voltage-gated calcium channels (VGCCs) are protein complexes composed of an α_1 pore-forming subunit and auxiliary subunits β and $\alpha_2\delta$. VGCCs of cochlear inner hair cells (IHCs) are mainly composed of the subunits $\text{Ca}_v1.3$ (contributing to ~90% of I_{Ca} ; Platzer et al., Cell 2000) and β_2 (contributing to ~70% of I_{Ca} ; Neef et al., J. Neurosci. 2009), and lack of either $\text{Ca}_v1.3$ or β_2 causes deafness. So far, expression and contribution of the four $\alpha_2\delta$ subunits $\alpha_2\delta_1$ -4, which assist in channel trafficking and can modulate I_{Ca} gating properties, are unknown.

We investigated mRNA expression of $\alpha_2\delta_1$ -4 in sensory inner and outer hair cells (OHCs). Both, immature IHCs and OHCs (P6) predominantly expressed $\alpha_2\delta_2$ as well as little $\alpha_2\delta_3$ (IHCs). In mature IHCs (=P20, after the onset of hearing), only $\alpha_2\delta_2$ mRNA could be detected at low levels around the detection threshold. To elucidate the role of the $\alpha_2\delta_2$ subunit for hair cell function, we analyzed an $\alpha_2\delta_2$ null mouse mutant, the ducky mouse ($\alpha_2\delta_2^{\text{du/du}}$).

The mean ABR threshold for click stimuli was significantly increased from 14.7 ± 2.9 dB SPL ($n = 16$ ears) to 33.0 ± 12.9 dB SPL ($n = 15$ ears) in $\alpha_2\delta_2$ wildtype compared with $\alpha_2\delta_2^{\text{du/du}}$ mice indicating a moderate hearing loss in the mutants. Otoacoustic emissions of $\alpha_2\delta_2^{\text{du/du}}$ mice were not impaired or were even larger than in controls, pointing to normal OHC mechanics. Whole-cell recordings revealed that mature IHC Ca^{2+} channel currents with Ba^{2+} as charge carrier were smaller ($\alpha_2\delta_2^{\text{du/du}}$: 142.9 ± 29.6 pA, $n = 11$ versus wild-type: 201.6 ± 38.3 pA, $n = 12$) and the averaged I-V curve was shifted by 7 mV to the right. This means that in vivo, the depolarization-induced calcium influx into the IHC will be reduced and Ca^{2+} channels will be activated at higher sound pressure levels only. In summary, reduced currents through $\text{Ca}_v1.3$ channels of the IHCs can explain the hearing deficit of $\alpha_2\delta_2^{\text{du/du}}$ mice.

Synaptic morphology of $\alpha_2\delta_2^{\text{du/du}}$ was assessed by immunostaining of synaptic proteins. Presynaptic $\text{Ca}_v1.3$ - and postsynaptic GluR2/3-immunopositive spots appeared normal and were found in close apposition with synaptic ribbons. In future experiments, we will measure Ca^{2+} currents and exocytosis and will quantitatively analyze the synaptic organization of IHCs of this new hearing-impaired mouse model.

Mechanical two-tone-distortions in the tympanum motion of locusts

Doreen Möckel, Manfred Kössl¹, Manuela Nowotny¹

¹Goethe Universität Frankfurt, Institut für Zellbiologie und Neurowissenschaft, Max-von-Laue-Str. 13, 60438 Frankfurt am Main, Germany

During stimulation with two pure-tones f_1 and f_2 , tympanal organs of insects emit pronounced distortion-product otoacoustic emissions (DPOAEs) which resemble those measured in the ears of vertebrates. They are indicative of non-linear ear mechanics and appear as additional spectral peaks at frequencies such as $2f_1-f_2$ or $2f_2-f_1$. The largest $2f_1-f_2$ amplitudes are reached at frequencies of high auditory sensitivity. There is evidence that the scolopidia, the auditory mechanoreceptors in tympanal organs, are involved in their frequency-specific generation [Möckel et al.: J Comp Physiol A193, 2007]. Our current study aims to measure the mechanical correlates of DPOAEs within the movement of the tympanal membrane of the locust *Schistocerca gregaria*.

We analysed the movement of the tympanal membrane during stimulation with the two pure-tones. The frequencies of both stimuli had been optimized to evoke large emissions using a closed system to record sensitive DPOAEs in insects. The same frequencies were then used for the open system measurements required by the laser Doppler vibrometry. The laser measurement points were arranged around the potential generation site of the DPOAEs, that is, the attachment point of the scolopidial mechanoreceptors at the tympanal membrane. Stimulation levels of f_1 and f_2 started at 30 dB SPL and reached up to 70 dB SPL.

During stimulation with two pure tones f_1 and f_2 , the amplitude response of the tympanal membrane showed additional peaks at the emission frequency $2f_1-f_2$. The $2f_1-f_2$ mechanical displacement level was 43 dB below the f_2 amplitude which is comparable to the OAE recording situation when using a closed acoustical measurement system. The $2f_1-f_2$ tympanum displacements amounted up to about 0.25 nm for single measurement points which were located close to the attachment area of the scolopidia. The threshold to evoke a $2f_1-f_2$ mechanical response in the tympanum movement during these open-system measurements lay at about 50 dB SPL stimulation level.

We demonstrate the existence of mechanical two-tone-distortions in the movement of the tympanal membrane at the $2f_1-f_2$ frequency. The largest displacement amplitudes and therefore potential place of their generation lies close to the attachment point of the dendrites of the receptor cells.

Funding. This project was supported by a grant from the Deutsche Forschungsgemeinschaft (No. 841/1-1), and by a "Nachwuchswissenschaftler/innen im Fokus" grant from the Goethe Universität, Frankfurt, Germany.

Optoacoustic stimulation of single cells

Alexander Rettenmaier, Thomas Lenarz¹, Günter Reuter¹

¹Hannover Medical School, Department of Otolaryngology, Carl-Neuberg-Str. 1, 30625 Hannover, Germany

It has been shown that inner ear cells can be stimulated in vivo by laser pulses resulting in cochlear potentials corresponding to auditory evoked signals. The idea is to use these laser pulses to replace the function of damaged outer hair cells. Without them the dynamic range and frequency discrimination is significantly decreased, which drastically impairs speech understanding in noise. Optical stimulation can be very site specific and hence because of the tonotopy of the cochlea very frequency specific, overcoming the limitations of conventional hearing aids as well as of electrical cochlea implants. To investigate the basic effects and mechanisms of optoacoustic stimulation, single cell measurements were performed.

Transfected HEK-hCIC-4 cells as model cells as well as isolated cells of the cochlea were stimulated with 5 ns laser pulses. Their reactions on different laser parameters such as pulse energy and wavelength were detected by means of the whole cell patch clamp technique.

Irradiated HEK-hCIC-4 cells show a significant change in the measured membrane current, depending on wavelength and pulse energy of the laser light as well as the depolarization of the cell. These reactions are clearly elicited by the laser beam and can be observed at the voltage clamp measurements as current spikes on a timescale of around 100 μ s. The spike amplitudes show a linear dependence on laser pulse energy and the wavelength dependence of the cell reaction is in good agreement with the wavelength dependence of the absorption coefficient of water. First experiments on spiral ganglion cells demonstrate similar reactions to laser irradiation.

The results show cell reactions due to physiologically relevant optical stimulation. Further studies will have to clarify to which extent the reaction is induced by thermal or optoacoustic stimulation or even the combination of both mechanisms.

Hearing in *Drosophila* requires visual rhodopsins

David Piepenbrock, Pingkalai R. Senthilan^{1,2}, Martin C. Göpfert¹

¹Johann-Friedrich-Blumenbach-Institut für Zoologie, Cellular Neurobiology, Julia-Lermontowa-Weg 3, 37077 Göttingen, Germany

²Neurobiology and Genetics, University of Würzburg, Am Hubland, 97074 Würzburg, Germany

Expression profiling revealed that key phototransducer components are expressed in the *Drosophila* Johnston's organ (JO), including Trp and Trpl, the visual arrestin arr2, the G-protein subunits G β 76C and Gy30A, the phospholipase NorpA, the protein kinase InaC, and four of the fly's six visual rhodopsins (Rh3-6). Expression in the auditory organ was confirmed by *in situ* hybridization, and mutant analysis showed that many of the respective genes are required for proper mechanical amplification which, in the fly, is linked to auditory stimulus transduction. In Rh5 and Rh6 null mutants, mechanical amplification was reduced and auditory afferent responses were diminished. Stronger auditory phenotypes characterized Rh5, Rh6 double mutants and *santa-maria* mutants that lack the visual chromophore. Electron microscopy revealed normal auditory neuron and cilium structure for Rh5, Rh6 double mutants. Antibodies against the respective rhodopsins labeled the somata of the neurons and their mechanosensitive ciliary tips. Mechanical correlates of mechanotransducer gating were largely reduced in Rh5 and Rh6 single mutants. In Rh5, Rh6 double mutants, the correlates were lost. Visual rhodopsins thus seem to facilitate transducer gating in a non-redundant manner in the fly's JO.

Mechanical Tuning of the High-Frequency Hearing Organ in Bushcrickets

Jennifer Hummel, Manfred Kössl¹, Manuela Nowotny¹

¹Goethe University, Cell biology and Neuroscience, Max-von-Laue-Straße 13, 60438 Frankfurt, Germany

The high-frequency hearing organ (*crista acustica*, CA) of bushcrickets is located within the tibiae of the forelegs. Earlier studies revealed a tonotopical representation of sound-induced amplitude maxima along the organ when stimulated with frequencies from 6 to 60 kHz at 80 dB SPL (Palghat Udayashankar et al. PLoS One. 2012;7(2):e31008). The anatomical basis for the found tonotopy, however, is unknown. It has been assumed that the varying mass of supporting cells on top of each dendrite, called cap cells, might influence sensory cell tuning by acting as mechanical resonators. To investigate the influence of possible mechanical resonances, we analyzed the sound-induced mechanical tuning of the CA as well as the anatomy of the hearing system in the tropical bushcricket *Mecopoda elongata*.

The mechanical vibration response of the CA was measured by laser-Doppler-vibrometry. For this purpose, pure-tone stimuli (2-77 kHz, 10-80 dB SPL) were applied. In a first series of experiments the mechanical response was determined at three different locations along the hearing organ (proximal, medial and distal). According to the predicted tonotopical preference of the sensory cells, low frequencies elicited the most sensitive vibration thresholds in the proximal region and high frequencies in the distal region of the CA. The tuning curves from the proximal and medial locations revealed distinct characteristic frequencies at stimulus frequencies of 7 and 17 kHz, respectively. In contrast, in the distal region no distinct characteristic frequency could be identified. Furthermore, we examined the anatomical features of the hearing system by analyzing the hearing organ structures on cross sections through the CA. The anatomical investigations of the CA revealed a steady decrease in size of all relevant hearing-organ structures from the proximal to the distal end supporting the tonotopical distribution of displacement amplitude maxima. The fine tuning of the CA, especially the broad mechanical tuning curve with no distinct characteristic frequency measured at the distal region, however, seems to be influenced by unknown additional factors.

Funding: Jürgen Manchot Foundation, DFG (NO 841/1-1) and Hanne and Torkel Weis-Fugh Fund.

A Viscoelastic Model of Adaptation in Mammalian Auditory-Nerve Fibers

Adam Peterson, Peter Heil¹

¹Leibniz Institute for Neurobiology, Department of Auditory Learning and Speech, Brenneckestraße 6, 39118 Magdeburg, Germany

The responses of mammalian auditory-nerve fibers to acoustic stimuli show pronounced adaptation and recovery from adaptation. During a tone of constant amplitude, the spike rate declines markedly, particularly during the first tens of milliseconds following stimulus onset. Upon cessation of the tone, the spike rate drops to values below the spontaneous rate, followed by a gradual recovery. A variety of functions have been ascribed to adaptation, including shifting the neuron's sensitivity range so it maintains sensitivity to stimulus changes even in the presence of high-amplitude backgrounds. Most models of the adaptation behavior of mammalian auditory-nerve fibers assume the cause to be the depletion of pools of synaptic vesicles in the pre-synapses of inner hair cells. However, recent research in mammalian systems suggests the presence of two alternative adaptation mechanisms that are reflected in changes to transducer currents and membrane potentials. A fast mechanism is thought to close inner hair cell transducer channels upon binding of calcium ions, whereas a slow mechanism is thought to relieve tension on the channels via the slippage of myosin motors in the stereocilia. These two processes are often modeled as exponential decays. Here, we examine whether a double exponential decay model with viscoelastic mechanical behavior, inspired by the work of Howard and Hudspeth (PNAS 1987), can describe the responses of mammalian auditory-nerve fibers over the entire peristimulus time course.

Spike times were obtained from extracellular recordings of auditory-nerve fibers in barbiturate-anesthetized cats. Stimuli were 100-ms tones of different sound pressure levels at each of the frequencies used (mainly characteristic frequency), presented with at least 100 repetitions at a rate of 4 Hz. Prior attempts to characterize adaptation have mainly involved fitting parametric models to post-stimulus time histograms (PSTHs). However, such fits produce parameter estimates that depend on the chosen bin width. We instead fit our model to curves of the cumulative spike count to avoid this problem. Cumulative spike count functions maintain maximal temporal precision and thus retain more information than most PSTHs, yet are smooth and allow precise fits.

The viscoelastic model proposed here incorporates fast and slow exponential decay and recovery components, with a comparable number of parameters to classical models. We found that the viscoelastic mechanical model of adaptation can describe the data with small and unsystematic residual errors, throughout the entire peristimulus time interval. Furthermore, the parameters have simple physiological interpretations and seem to show meaningful relationships to stimulus parameters.

The viscoelastic description of adaptation may constitute a viable alternative to the assumption that vesicle depletion and re-supply are the prime factors underlying adaptation in mammalian auditory-nerve fibers. It is plausible that slow adaptation with a myosin motor and fast adaptation mediated by the binding of calcium ions at or near transducer channels play more prominent roles than suggested in previous models.

Supported by the Deutsche Forschungsgemeinschaft (SFB-TR 31 A6).

Determination of dynamic vesicle pools in inner hair cell ribbon synapses

Carolin Wichmann, Elisabeth Auge¹, Ellen Reisinger¹, Tobias Moser¹

¹University Medical Center Göttingen, Inner Ear Lab, Dept. of Otolaryngology, Robert-Koch-Str. 40, 37075 Göttingen, Germany

Encoding auditory signals into a neuronal code, the central process of hearing, in vertebrates is mediated through the ribbon synapses of the inner hair cells (IHCs) and spiral ganglion neurons. Acoustic information is transmitted with high temporal precision over long periods of time requiring high rates of transient and sustained release. Disruption of the synapse structure can result in deficits in neurotransmitter release. Presently, we lack an integrated understanding of the molecular machinery constituting the presynaptic active zone and coordinating vesicle release. To approach this question, we study mutants of active zone proteins that show impairment in function. Here, we concentrate on mutants for the protein Otoferlin to address two aspects: I. synapse structure and II. dynamics of synaptic vesicle pools. Recent advances in electron microscopy technology allow us to generate highest resolution images of close to native synaptic morphology that can be used to interpret functional events at the synapse. Through a combination of high-pressure freezing/freeze-substitution (HPF/FS) and electron-tomography we perform detailed analysis of the ribbon synapses. Here, we present first results obtained from the comparison of inhibited and stimulated high-pressure frozen wild type and mutant IHC ribbon synapses. We determined such parameters as the synaptic vesicle (SV) diameter, the number of SVs close to the membrane, and ribbon-associated SVs, depending on the activity state.

Temporal integration in the auditory pathway of the grasshopper

Sarah Wirtsohn, Bernhard Ronacher^{1,2}

¹Humboldt-University Berlin, Germany

²Bernstein Center for Computational Neuroscience Berlin, Germany

In many grasshopper species acoustic communication plays a crucial role in mating behavior. Typically, a male exhibits a species-specific calling song, to which a female may respond, and the male can then use the female song for a phonotactic approach. The auditory system of grasshoppers must thus be able to extract species-specific signals in a noisy habitat, with the sound envelope acting as the decisive cue for signal recognition. This well-defined task makes the grasshopper a suitable model for investigating basic properties of neuronal processing underlying sensory computations in a small neural network.

•
An important part of auditory preprocessing takes place in the metathoracic ganglion in a small feed forward-network constituted by three types of neurons. Approximately 60-80 excitatory receptor neurons (RNs) per ear convey information to local interneurons (LNs). These LNs give inhibitory and excitatory input to the ascending neurons (ANs), which in turn project to the brain. While the firing rates of the RNs and LNs correspond to basic features of the auditory stimulus such as sound intensity, the ANs extract specific, rather complex features such as lateralization of the sound source, pause duration between stimuli and onset intensity (Clemens et al. 2011, 2012).

•
Temporal integration is one of the basic properties of the auditory system in numerous species. It underlies different phenomena, such as a shift in detection threshold as a function of sound duration or of the time between two short signals. Interestingly, integration time constants differ when determined by different kinds of experiments. Several theoretical models have been used to describe integration time constants in various auditory systems.

•
In the present study, we explore the temporal integration in LNs and ANs in *Locusta migratoria*. We stimulate with short broadband single and double clicks (duration 40 μ s) while simultaneously performing intracellular recordings. Neurons are stained and morphologically identified after the experiment. We vary three parameters in double click stimuli: Sound pressure level, inter-click intervals and relative click amplitude. Thus, we can determine the integration of stimuli in LNs and ANs as a function of both intensity and time.

•
The temporal integration of double clicks in auditory receptor neurons in insects is consistent with an energy detector model (Tougaard 1996, Gollisch et al. 2002) – hence, in receptors the detection threshold for double click stimuli is lower than for single clicks. This effect appears to apply also for the majority of the LNs, but nonlinear effects, most likely resulting from the network activity of excitatory and inhibitory synaptic inputs, take place in the ANs. Temporal integration thus seems to change with the level of auditory processing.

•
•
References:

Clemens, J., Kutzki, O., Ronacher, B., Schreiber, S., Wohlgemuth, S. (2011); PNAS 108: 13812-13817

•

Clemens, J., Wohlgemuth, S., Ronacher, B. (2012); J Neurosci 32: 10053-10062

•

Gollisch, T., Schütze, H., Benda, J., and Herz, A. V. M. (2002); J Neurosci 22: 10434–10448

•

Tougaard, J. (1996); J Comp Physiol A 178: 669-677

Auditory processing in a bush-cricket interneuron

Timothy George Bayley, Berthold Hedwig¹

¹University of Cambridge, Department of Zoology, Downing Street, CB2 3EJ Cambridge, United Kingdom

The auditory system of the bush-cricket (*Mecopoda elongata*) is able to discriminate well between frequencies of sound. This is reflected in its calling song – a broadband call (4-80 kHz) with high power in specific frequency ranges. But how does the auditory system deal with this signal? The peripheral auditory apparatus, the auditory afferents, are arranged tonotopically, and this arrangement is maintained in the central nervous system. Furthermore, frequency tuning is sharpened by primary afferent depolarisations. Using a combination of electrophysiology and calcium imaging we are studying interneuron function and how this map of ‘frequency space’ is processed within the central nervous system. The primary candidate for study is the omega neuron (ON1), which shows broad frequency tuning and also aids directional sensitivity in the auditory system, by reciprocal inhibition of each neuron and its contralateral partner. Previous work on the cricket ON1 has implicated calcium in driving this inhibition.

Using Peltier elements, each of the forelegs containing the ears can be independently cooled and information transmission reversibly blocked, with complete silencing of the auditory afferents occurring at temperatures below ~10°C. Intracellular recordings of ON1 reiterate the indication of mutual inhibition: cooling of the ear contralateral to the dendrites causes an increase of sound-evoked compound EPSP size and spiking; where cooling of the ipsilateral ear causes large IPSPs upon acoustic stimulation. To a 20ms sound pulse, the duration of these potential changes (~300ms) is far greater than the duration of afferent spiking (~20ms), and may well be imparted by calcium currents. A primary aim is to study if and how tonotopy is maintained at this level of auditory processing, and these calcium currents are being used to do so. In turn, we aim to see any frequency-dependent processing by the neuron. The function of the map of frequency space can be implied, as the spread of membrane currents and intracellular ions will define the acuity of any frequency-specific processing.

Furthermore I aim to use the intracellular recording electrode for specific application of pharmacological agents to pick apart the source and role of these calcium transients: do they originate extracellularly or from internal stores? Do they activate calcium-sensitive potassium channels? These kinds of questions are often asked but seldom addressed in studies of calcium signalling.

Auditory Characterisation of $Ca_v2.3^{-/-}$ mice using Auditory Brainstem Responses

Marco Weiergräber, Anna Papazoglou¹, Ralf Müller², Christina Henseler¹, Karl Broich¹, Roger Miller³, Andreas Lundt¹

¹Federal Institute for Drugs and Medical Devices (Bundesinstitut für Arzneimittel und Medizinprodukte, BfArM), Kurt-Georg-Kiesinger-Allee 3, 53175 Bonn, Germany

²Department of Psychiatry and Psychotherapy, Cologne Cognitive Neurophysiology Lab (CCNL), University of Cologne, 50924 Cologne, Germany

³Molecular Pharmacology and Biological Chemistry, Northwestern University Feinberg School of Medicine, Chicago

Voltage-gated Ca^{2+} channels are functional key elements in the auditory system. High-voltage activated $Ca_v1.3$ channels for example are expressed in the outer hair cells of the organ of Corti and systemic ablation of this subunit has been shown to cause cardiac arrhythmia and congenital deafness associated with cochlear pathomorphology. Although $Ca_v2.3$ R-type Ca^{2+} -channels are also expressed in outer hair cells of the organ of Corti, their functional impact in the auditory tract is unclear. In order to evaluate the role of $Ca_v2.3$ channels in the auditory neural pathway and to gain insight into the hearing status of $Ca_v2.3$ knock-out, we performed auditory brainstem response (ABR) recordings in $Ca_v2.3^{-/-}$ as well as control mice aged 4 - 50 weeks.

ABR is a common tool to investigate hearing impairments in humans as well as in animal models. Animals were anesthetized with ketamine/xylazine (100/10 mg/kg i.p.) and electrodes were placed subcutaneously axial and rostral from the pinnae. We used clicks and tone bursts (6-72 kHz) as auditory stimuli to create an auditory profile including general auditory activity, hearing range and threshold. Latency, amplitude and attendance of neuronal ABR generators are used to detect differences in hearing and possible deficits in the neural pathway. We compared C57Bl/6J, $Ca_v2.3$ wild-type, heterozygous and knock-out mice from both genders. Our results illustrate that $Ca_v2.3$ knock-out mice do not suffer from congenital deafness and point to an exceptional functional specialisation of voltage-gated Ca^{2+} channels in the auditory tract.

Does stress alter hearing through direct effects in the cochlea?

Mirko Jaumann, Wibke Singer¹, Sze Chim Lee¹, Kamyar Kasini¹, Lukas Rüttiger¹,
Marlies Knipper¹

¹University of Tübingen, THRC, Elfriede-Aulhorn-Str. 5, 72076 Tübingen, Germany

Excessive noise is a global health hazard with considerable pathophysiological and social consequences, leading to noise-induced hearing loss (NIHL) and presbycusis, both currently with no successful clinical treatment. NIHL is a serious health problem that will affect increasing populations worldwide (NIDCD). Recent findings indicate that also reversible hearing loss, that is characterised by only temporary threshold shift, may result in a slow degeneration of auditory nerve fibres (AN) and progressive damage of the inner hair cell (IHC) synapse (ribbon loss) (Kujawa and Liberman 2009). The altered leisure behavior of young people (e.g. use of personal headsets) together with demographic changes, makes progressing hearing loss and co morbidities as e.g. tinnitus and hyperacusis to a serious health issue.

We recently confirmed the loss of IHC synaptic ribbons and a subsequent deafferentation in situations of mild auditory trauma (Rüttiger et al., 2012, Singer et al., 2012) and described the inhibition of PDE-5 as a pharmaceutical treatment to reduce noise induced neuronal damage (Jaumann et al., 2012).

In the recent study, we examined differential effects of stress on hair cells or its afferents, and how these effects can be explained by different corticosteroid levels.

Using a stress paradigm in combination with drugs that interfere with a cGMP signaling pathway we analyze the effect of corticosterone and cGMP on deafferentation following acoustic overstimulation. First data will be presented and discussed in the context of a so far elusive mechanism of how stress can interfere with hearing.

Supported by fortune 2074-0-0, Marie Curie Research Training Network CavNET MRTN-CT-2006-035367, Deutsche Forschungsgemeinschaft, grant DFG-Kni316-8-1

Three dimensional acoustic orientation in insects

Nanina Tron, Liesa-Kristin Beuter¹, Reinhard Lakes-Harlan¹

¹Justus-Liebig-Universität Gießen, Institute for Animal Physiology, AG Integrative Sensory Physiology, Heinrich-Buff-Ring 38, 35392 Gießen, Germany

Acoustic communication in insects is quite common and evolved several times in different groups. In intraspecific acoustic communication, usually males produce a calling song, whereas the females perform phonotaxis towards the sound source. Additionally, in some systems parasitic flies can exploit the sexual acoustic signals for their host detection.

In this project we investigated acoustic behaviours in the parasitoid-host-system of the parasitoid fly *Emblemasoma auditrix* and their host, the cicada *Okanagana rimosa*. The male cicadas call for their female mating partner and this signal attracts female cicadas as well as females of the parasitoid fly. Therefore it is possible to comparatively investigate phonotaxis of two different species towards the same signal in the same habitat. This system also provides the unique possibility to investigate three dimensional acoustic orientation.

In field experiments an artificial calling song of *O. rimosa* was broadcasted from a loudspeaker and the behaviour of the phonotactically active insects was recorded. Different experimental setups and habitat structures were used to analyse the complex phonotactic behaviour. Here, data on the phonotactic orientation in the vertical plane are presented.

The acoustic localisation of the sound source is rather accurate in both species and distinct characters can be extracted: Up to 70% of the animals landed above the speaker, indicating a bias in vertical orientation. This bias is hypothesized to be related to the ventrally positioned ear in both species. By contrast, analysis of the starting position of *E. auditrix* at the beginning of phonotaxis show that the orientation of the longitudinal body axis of the fly points below the target position (Figure A, B). Nevertheless, the orientation angle correlates well to the target angle (Fig. B). The positional information present at the start seems not to be decisive and corrections can be made during flight. Additionally, the fly regularly uses landmarks during phonotaxis for landing and re-orientation.

In summary, both species are able to locate a sound source in the vertical axis. *E. auditrix* might use a bouquet of acoustic cues for phonotaxis, while *O. rimosa* might rely more on phonotaxis during flight. Future studies will unravel the unknown biophysical mechanics for acoustic orientation in the vertical axis.

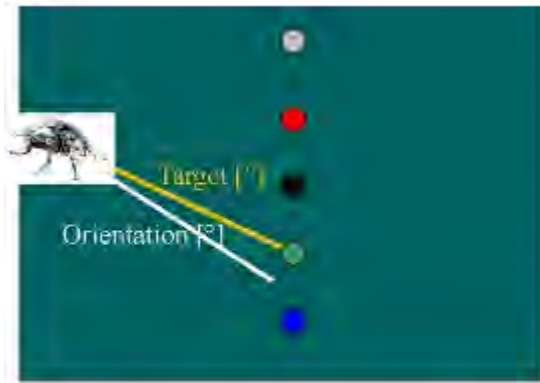
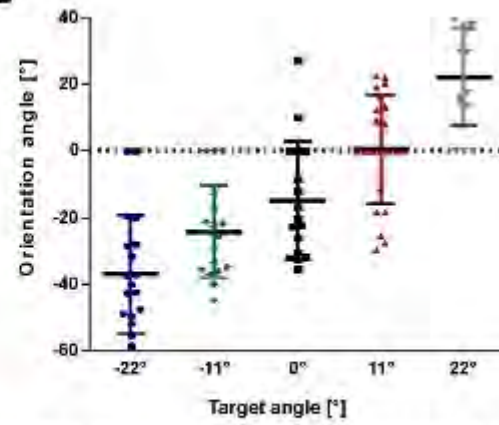
A**B**

A: Schematic setup indicating the different loudspeaker positions (coloured circles) and the two angles from a starting position. B: Correlation of the target angle and the orientation angle (data points with mean).

Vibration perception in Orthoptera

Reinhard Lakes-Harlan, Philipp Keil¹, Robert Kügler¹, Heusler Jan¹, Strauss Johannes¹

¹Institute of Animal Physiology, Integrative Sensory Physiology, Heinrich Buff Ring 26, 35392 Gießen, Germany

Vibration perception is a common capability of insects. Interestingly, many different sensory structures evolved for that task. A highly sensitive vibration receptor organ is the subgenual organ, which is present in many insect species. The subgenual organ is often part of a sensory complex in the proximal tibia. The function and evolution of the other parts of the sensory complex are less well understood. One part seems to be the predecessor organ of the hearing organ in Ensifera. This predecessor organ, the crista acustica homolog (CAH), is present in many recent Ensifera in atympanate legs. It has been proposed that the predecessor organ has a vibratory function in addition to the subgenual organ. However, this hypothetical function is still unknown.

Here we investigate vibratory responses in the tettigoniid, *Mecopoda elongata* and compare the responses to the locust *Schistocerca gregaria*, which does not possess a CAH. Vibration thresholds were recorded from the pro- and mesothoracic leg. Each leg was stimulated from three perpendicular directions, with the Y-axis aligned to the longitudinal axis of the tibia.

The results show that the vibratory responses of both legs of *Schistocerca gregaria* are rather similar. The vibration threshold is around 0.1 ms^{-2} at about 500-700 Hz. Interestingly, the responses did not differ between the stimulation directions. The vibratory thresholds of *Mecopoda elongata* differed from those of *S. gregaria* in the shape of the threshold curve and the most sensitive range is between 500-1000 Hz. Furthermore, vibration threshold curves of *M. elongata* differ between the prothoracic leg and the mesothoracic leg in one stimulus direction. The mesothoracic leg reacts similar to all stimulus directions; in the prothoracic leg the shape of the threshold curve for stimulation in the X-axis is different from the other directions. Ongoing experiments will reveal whether the CAH in the mesothoracic leg and the hearing organ in the prothoracic leg are decisive for the different shapes of the threshold curves.

Functional categorization of abducens motoneurons as the basis for appropriate dynamic tuning of vestibulo-ocular responses in *Xenopus laevis*.

Haike Dietrich, Hans Straka¹

¹Ludwig-Maximilians-University Munich, Department Biology II - Neurobiology, Großhaderner Straße 2, D-82152 Planegg-Martinsried, Germany

²Graduate School of Systemic Neurosciences, Ludwig-Maximilians-University Munich, Germany

Vestibulo-ocular reflexes (VOR) are a major contributor to gaze stabilization during passive or self-generated head and body movements in all vertebrates. Abducens motoneurons, which innervate the lateral rectus muscle, transform, integrate and relay visuo-vestibular inputs into reactive motor commands for compensatory eye movements in the horizontal plane. The large dynamic range of natural head displacements necessitates an equally large range of eye motion dynamics and thus a variety of motoneuronal subtypes in order to ensure the generation of spatio-temporally appropriate motor commands for muscle contractions. Compatible with the notion of the VOR circuitry as parallel, frequency-tuned pathways from the sensory periphery to the motor effector, extraocular motoneurons likely distinguish into functional subtypes that are ideally suited for specific behavioral tasks. The current study aims to investigate the diversity of abducens motoneurons with respect to their morphology, activation pattern, discharge properties and synaptic pharmacology. Experiments were performed on semi-intact preparations of larval *Xenopus laevis*, which allow *in-vitro* manipulations within fully functional neuronal circuitries of the VOR. Multiple-unit extracellular nerve recordings during natural stimulation of the vestibular endorgans revealed that abducens motoneurons essentially subdivide into tonic and phasic units with respect to activation threshold and discharge regularity. Spike shape analysis and specific pharmacological blockade of excitatory and inhibitory synaptic transmission suggest that this segregation also coincides with a differential expression of glutamate receptor subtypes in different motoneurons. Calcium imaging of retrogradely labeled abducens motoneurons during electrical stimulation of the vestibular periphery revealed a differential activation pattern, respectively, in association with their morphology and location within the entire neuronal population. Simultaneous nerve recordings allowed linking the differential discharge properties of abducens motor axons to the corresponding calcium signal in the cell bodies. Together these findings strongly support the notion of separate functional subgroups of extraocular motoneurons that differ from each other in interrelated morpho-physiological properties, ideally suited to transmit the large range of extraocular motor commands.

Ontogenetic plasticity of linear vestibulo-ocular reflexes in *Xenopus laevis*

Francisco Branoner, Hans Straka¹

¹Ludwig-Maximilians-Universität München, Division of Neurobiology, Department Biology II, Großhardener Straße 2, 82152 Planegg-Martinsried, Germany

Vestibulo-ocular reflexes (VOR) cause gaze-stabilizing eye movements during locomotion that optimize visual perception. During amphibian development and metamorphosis from tadpoles into adults, the position of the eyes change considerably and semicircular canal size and thus sensitivity and gain increases significantly. Accordingly, spatio-temporally appropriate gaze stabilization requires an adaptive plasticity that takes into account the developmental transition of the eyes from a lateral to a more dorsal position and the onset of semicircular canal function. These ontogenetic changes in combination with the accessibility for morpho-physiological experiments make larval stages of *Xenopus laevis* excellently suited to study the adaptive developmental plasticity of the VOR. Here, we used otolith-derived linear vestibulo-ocular reflexes (IVOR) to study the spatio-temporal tuning during larval development. During sinusoidal linear acceleration of semi-intact in vitro preparations of *Xenopus* tadpoles, effective vertical/torsional eye movements were captured non-invasively by a high-speed video camera or single- and multiple-unit activity was recorded with suction electrodes from the trochlear nerve that innervates the superior oblique eye muscle. Various peak-accelerations (0.001-0.14 g) and orientations of the preparation relative to the direction of the acceleration vector (0-360°, altered in steps of 5-15°) were used to determine the spatial tuning properties of the IVOR. A considerable plasticity of otolith-driven extraocular motor responses was encountered during the premetamorphic period. Young larvae (stage 46-48) exhibited rotational eye movements in the vertical plane up to $\pm 20^\circ$ and a distinct trochlear nerve discharge modulation, however, without a major preferential direction selectivity of the response vectors. Older tadpoles (stage 49-54) showed a significant reduction of the ocular motor range, accompanied by a trochlear nerve discharge with a directional selectivity that approximately matched the ipsilateral posterior semicircular canal plane. Late larval stages (stage 55-58) and animals at metamorphic climax (stage 59-61) showed only minimal ($< 5^\circ$) or no eye movements during linear acceleration and a moderate, directionally selective discharge modulation (stage 55-58) or weakly modulated (stage 59-61) trochlear nerve activity. While an acceleration-dependent response modulation was absent in the latter animals, the overall firing rate changed significantly with the orientation angle relative to the acceleration vector. These ontogenetic changes in the sensory-motor transformation of vestibular signals likely reflect progressive alterations of the interaction between otolith signals, present immediately after hatching and semicircular canal inputs, delayed by the late maturation and the necessity to reach a particular size for the functional onset and a sufficient large gain of sensory-modulated vestibular afferent discharge modulation.

Multimodal map formation of two sensory modalities without visual teacher: a dynamical model for the blind mexican cavefish *Astyanax Mexicanus*.

Matthias Krippner, Julie Goulet¹, J. Leo van Hemmen¹

¹Physik Department T35, TU München and Bernstein Center for Computational Neuroscience, Garching, Germany

About fifty percent of all vertebrates are fish. Since fishes live in water where often light (and therefore vision) is not a useful signal they should relate to other sensory inputs. One of them is water motion that they can detect with their mechanosensory system. The mechanosensory lateral line system, unique to aquatic vertebrates, is divided into two subsystems, namely superficial (SN) and canal neuromasts (CN) that both show different response properties to hydrodynamic stimuli. Previous studies showed that SNs encode water velocity, CNs respond to its first derivative, namely water acceleration.

From previous work we also know the spatiotemporal distribution of firing rates for SNs and CNs based on the hydrodynamics of a sphere moving along the fish's lateral line system. The key question we are investigating now is how fishes can use these two input modalities to build an internal representation of an object moving at a certain position and distance. We show that a single-layer network is capable to reliably extract the position information even from noisy sensory input. The integration of both SN and CN signals within a multimodal map further stabilizes the localization, but it is also crucial to the learning process. In particular, animals such as the Blind Mexican Cavefish (*Astyanax Mexicanus*) that lack visual input as a distinctive teacher need to strongly exploit correlations between different modalities of the rather blurred lateral-line input and the feedback coming from higher brain area to still be able to learn a precise map. By using nonlinear optimization techniques we derive a suitable Hebbian learning rule that leads to stable somatotopic alignment of SN and CN input. In our simulations an additional visual teacher shows no particular improvement in the learning process. Finally we study the initial conditions that enable multimodal integration in a neuronal system such as the lateral-line system of fish.

Spike-rate resonances in small neuronal networks: from the cricket auditory system to general models

Florian Rau, Jan Clemens^{1,2}, Viktor Naumov¹, Wei Wu³, R. Matthias Hennig¹, Susanne Schreiber^{2,3}

¹Department of Biology, Humboldt-Universität zu Berlin

²Bernstein Center for Computational Neuroscience Berlin

³Institute for Theoretical Biology, Humboldt-Universität zu Berlin

Rhythms in neural system are observable on all levels of complexity - from the regular spiking in single cells to oscillatory interactions between whole brain areas. For the processing of periodic signals which carry information in specific frequency bands, a neuronal system may profit from tuning its filter properties towards a peak sensitivity in the relevant frequency range. We used the cricket *Gryllus bimaculatus* as a model system for investigating the processing of rhythmic signals, since crickets produce a temporally patterned song characteristic of its own species to attract mating partners. Here we investigated whether bandpass properties were present at an early level of auditory processing.

Extracellular recordings from three types of first order auditory neurons (ON1, AN1 and AN2) were performed. For acoustic stimulation, a pure-tone carrier of either 4.5 or 16 kHz was combined with a swept-frequency amplitude modulation from 1 to 100 Hz. These stimuli allowed for a fast coverage of a wide frequency range and included the characteristic pulse frequency of the species' own calling song (approx. 25 Hz). Transfer functions extracted from spike response spectrograms revealed that some of the recorded cells revealed moderate bandpass properties towards modulation frequencies relevant to the species.

In order to understand the experimentally observed effects, three basic computational models were explored. These models covered the most likely components for implementing a neuronal bandpass filter by utilizing different well-established mechanisms on single cell and network level: sub-threshold oscillations, adaptation, and interplay of excitation and inhibition. Remarkably, all three models were able to reliably produce resonant peaks of the firing rate similar to the ones observed experimentally.

Our results show that moderate bandpass properties at the first level of auditory processing may support processing of periodic signals at higher levels in the cricket brain. Three very different models - from single oscillatory neurons to small networks of neurons - could reproduce the observed tuning characteristics and are plausible candidates to achieve bandpass filtering in small neural networks.

Analysis of a mouse model with a missense mutation in otoferlin

Ellen Reisinger, Hanan Al-Moyed¹, Tina Pangrsic², Tobias Moser², Nicola Strenzke³

¹University Medical Center Göttingen, Molecular Biology of Cochlear Neurotransmission Group, Dept. for Otolaryngology, Robert-Koch-Str. 40, 37075 Göttingen, Germany

²University Medical Center Göttingen, InnerEarLab, Dept. for Otolaryngology, Robert-Koch-Str. 40, 37075 Göttingen, Germany

³University Medical Center Göttingen, Auditory Systems Physiology Group, Dept. for Otolaryngology, Robert-Koch-Str. 40, 37075 Göttingen, Germany

The multi-C2 domain protein otoferlin is highly expressed in sensory hair cells of the inner ear. Mutations in otoferlin lead to deafness due to impaired synaptic transmission from hair cells to spiral ganglion neurons. Few missense mutations in otoferlin in humans have been described to lead to a less severe hearing phenotype which we aimed to analyze in an animal model. Therefore, we generated a knock-in mouse line with such a missense mutation in otoferlin.

We analyzed expression of otoferlin in hair cells of this knock-in mouse line by immunohistochemistry. Mutated otoferlin was distributed similarly to wild type otoferlin but with moderately lower expression levels. Next, we studied the impact of the mutation on exocytosis in hair cells by patch clamp recordings. These recordings revealed normal exocytosis rates for short stimuli but reduced sustained release rates. Further, auditory brainstem response recordings revealed elevated hearing thresholds in these mice. Our data indicate that this mouse line is a valuable model to study the effect of missense mutations in otoferlin on hair cell function and hearing.

Medullary lateral line units of the common Rudd, *Scardinius erythrophthalmus*, are sensitive to object position

Evelyn Dylka, Adrian Klein¹, Horst Bleckmann¹

¹University of Bonn, Institute of Zoology, Poppelsdorfer Schloss, 53115 Bonn, Germany¹

Fish can sense weak water fluctuations with their lateral line. Fish use their lateral line to detect predators and prey, for schooling, collision avoidance and energy efficient locomotion in unsteady flow. Columnar vortices (e.g. a Kármán vortex street) are shed downstream of a submerged object (i.e. a cylinder) in a wide range of Reynold numbers. Fish use Kármán vortex streets to reduce locomotory costs. Navigating in hydrodynamic perturbations – like Kármán vortex streets - is complex and information on flow perturbations may be advantageous. Peripheral and medullary lateral line units are sensitive to Kármán vortex streets. In previous physiological studies in which medullary lateral line units were recorded the position of an upstream cylinder, which also determines the spatial distribution of the Kármán vortex street, was not altered. Since the relative position of an upstream object is important for station holding, we investigated the influence of the cylinder position on the activity of medullary lateral line units of the common Rudd. Neuronal activity correlated with the vortex shedding frequency. In addition the position of the cylinder influenced the spike rate and spike pattern. This indicates that the information about cylinder position is conserved in medullary lateral line units.

The influence of CaBP2 on the biophysical properties of Inner Hair Cell Ca_v1.3 Ca²⁺ channels

Maria Magdalena Picher, Isabelle Schrauwen², Sarah Helfmann¹, Akira Inagaki³, Friederike Predoehl¹, Mohammad Amin Tabatabaiefar^{4,5}, Manou Sommen², Celia Zazo Seco⁶, Jaap Oostrik⁶, Hannie Kremer⁶, Annelies Dheedene⁷, Charlotte Claes², Erik Fransen², Morteza Hashemzadeh Chaleshtori⁵, Paul Coucke⁷, Amy Lee³, Guy Van Camp², Tobias Moser¹

⁷Center for Medical Genetics, Ghent University, 9000 Ghent, Belgium

Ca_v1.3 Ca²⁺ channels belong to the group of L-type Ca²⁺ channels and mediate neurotransmitter release from auditory inner hair cells (IHCs) in the cochlea. In IHCs Ca_v1.3 channels show fast activation at relatively low voltages and slow inactivation enabling faithful sound encoding over Ca²⁺ dependent inactivation (CDI) is generally weak in IHCs. This is thought to result from antagonism of CDI by Calcium binding Proteins (CaBPs). CaBPs are CaM-like EF-hand Ca²⁺ binding proteins and, in contrast to CaM, are restricted to the brain and sensory organs like the retina and cochlea. In this study we identified a splice site mutation in the CaBP2 gene (c.637+1G>T) inducing moderate-to-severe hearing loss in three consanguineous Iranian families. This mutation probably leads to skipping of exon 6 and a premature truncation of the protein. The truncated CaBP2 shows impaired Ca²⁺ binding properties and has reduced potency in regulating Ca_v1.3 channels in transfected HEK293T cells when compared to the wild type protein. In addition to the splice site mutation two missense mutations in the CaBP2 gene were identified (c.94R>G, c.121E>K) in patients with a similar phenotype. Preliminary results, however, indicated that their effects on Ca_v1.3 channels in transiently transfected HEK293-SK3-1 cells are comparable to wildtype CaBP2.

Discreet long-term monitoring of electric fish behavior

Jörg Henninger, Rüdiger Krahe², Jan Benda¹

¹Neuroethology, Dep. Biology II, Ludwig-Maximilians-Universität München, Germany

²Dept. Biology, McGill University, Canada

A prerequisite for the full understanding of sensory systems is knowledge about the natural context these systems evolved in. The electric sense of the gymnotiform electric fish *Apteronotus leptorhynchus* is a successful model system in research on the neural computations underlying behavior. These fish generate an electric organ discharge, which can be modulated in amplitude and frequency to create various communication signals. Much is known about the sensory system's anatomy and physiology as well as the fish's behavior and intra-specific communication signals. However, recent laboratory studies indicate that electrocommunication behavior depends strongly on the experimental situation. Further, the fish's behavior is subject to seasonal changes, e.g. mating-related behaviors occur during specific phases of the year only. Therefore, a better knowledge about the fish's behavior in its natural habitat is desirable, in particular for interpreting electrophysiological data of the electrosensory systems.

The present study targets just this question by providing and applying a novel method for undisturbed long-term monitoring of electric fish behavior. Using an array of electrodes, which is spread out over the fish's habitat and continuously records the electric fields of the fish, allows for tracking of individual fish's motion, communication signals, and conspecific interactions. Although the recorded signal traces often are superpositions of multiple fish signals, the method provided is able to robustly retrieve and analyze the original signals on a fine timescale. Here, we discuss the underlying principles, prospects and limits of our method. We present recent data from our study-site in Panama, where we monitored and characterized the local electric fish community, including *Apteronotus rostratus*, during the transition from dry to rainy season.

Poster Topic

T18: Auditory System: Subcortical and Cortical Processing

- T18-1A** Coincident inputs achieved by systematic variations of conduction velocity
Armin Harry Seidl, Edwin W Rubel, Andres Barria
- T18-2A** Masking Release due to Coherent Envelope Fluctuations across Frequency at the level of the Inferior Colliculus
Jan-Philipp Diepenbrock, Frank W. Ohl, Jesko L. Verhey
- T18-3A** The role of GABAergic and glycinergic inhibition in shaping SSA in the inferior colliculus of the anesthetized rat.
Yaneri A. Ayala, Manuel S. Malmierca
- T18-4A** DIFFERENTIAL EXPERIENCE-DEPENDENT PLASTICITY IN MOUSE INFERIOR COLLICULUS DEPENDING ON PRIOR EXPOSURE.
Hugo Cruces-Solis, Livia de Hoz
- T18-5A** Tinnitus related plasticity in auditory cortex of Mongolian gerbils
Sönke Ahlf, Konstantin Tziridis, Holger Schulze
- T18-6A** Representation of complex sounds in the mammalian inferior colliculus
Dominika Lyzwa, Michael Herrmann
- T18-7A** Fast and Differential Steroid Modulation of the Audio-Motor Integration in the Midbrain of the Toad *Bombina orientalis*
Christof Legler, Wolfgang Walkowiak
- T18-8A** Influence of Synaptic Inhibition on Output Rate and Timing in a Spherical Bushy Cell Model
Thomas Künzel, Jana Nerlich, Ivan Milenkovic, Hermann Wagner
- T18-9A** Distribution of extracellular matrix proteoglycans at the calyx of Held/principal neurons in the medial nucleus of trapezoid body in mice
Maren Blosa, Mandy Sonntag, Gudrun Seeger, Rudolf Rübsamen, Thomas Arendt, Markus Morawski
- T18-10A** Roles of GABA-mediated inhibition in the cortical processing of temporally-patterned sounds
Julio C. Hechavarria, Manfred Kössl
- T18-11A** Independent Response Adaptation of Excitatory and Inhibitory Inputs Allows Rapid Adjustment of Optimal Spatial Sensitivity in Lateral Superior Olivary Neurons

- T18-12A** Adaptation in the auditory midbrain of the barn owl induced by three double stimulation paradigms
Roland Feger, Martin Singheiser, Philipp Tellers, Mark von Campenhausen, Hermann Wagner
- T18-1B** Regularity-dependent changes in stimulus-specific adaptation in the auditory cortex
Sebastian Florian Betz, Bernhard H. Gaese
- T18-2B** Rat auditory cortical functioning and different aspects of performance in frequency discrimination tasks
Ann-Kathrin Riegel, Bernhard H. Gaese
- T18-3B** Hyperpolarization-activated currents shape temporal response properties in mouse superior paraolivary nucleus neurons
Katrin Vonderschen, Anna K. Magnusson
- T18-4B** Neural coding of target range in bats is influenced by reflections from water surfaces
Alexander Luis Warmbold, Uwe Firzlaff, Lutz Wiegrebe
- T18-5B** Directionality of hearing in domestic chicken (*Gallus gallus domesticus*)
Hans Andrea Schnyder, Dieter Vanderelst, Sophia Bartenstein, Uwe Firzlaff, Harald Luksch
- T18-6B** The hearing function of the deletion of L-type CaV1.2 in the peripheral and central auditory system
Sze Chim Lee, Annalisa Zuccotti, Somisetty V. Satheesh, Thomas Schimmang, Lukas Rüttiger, Hans Gerd Nothwang, Marlies Knipper
- T18-7B** Frequency-related topography of the corticofugal connections of field AI in the Mongolian gerbil
Eike Budinger, Michael Brosch, Henning Scheich, Judith Mylius
- T18-8B** "That's far below me!" - Pulse-Echo delay sensitivity in the vertical plane measured in the auditory cortex of bats
Susanne Hoffmann, Selina Prosch, Uwe Firzlaff, Lutz Wiegrebe
- T18-9B** Effects of two different hearing aids on sound processing in the primary auditory cortex of Mongolian gerbils
Konstantin Tziridis, Sönke Ahlf, Michael Heiden, Holger Schulze
- T18-10B** Glycinergic Inhibition Controls Synaptic Integration in the Medial Superior Olive
Michael Hideki Myoga, Simon Lehnert, Christian Leibold, Felix Felmy, Benedikt Grothe
- T18-11B** Telemetric study of neuronal activity in a song nucleus HVC reveals one neuron type that is involved in sensory-motor control of calls in zebra finches
Shouwen Ma, Lisa Trost, Manfred Gahr, Andries ter Maat
- T18-1C** Layer-specific processing of ultrasonic calls in the auditory cortical fields of mice

- T18-2C** Multimodal signal intergration in the *Drosophila* CNS
Philipp Jaehde, Martin Goepfert
- T18-3C** Simultaneous but not sequential bilateral lesion of gerbil auditory cortex does extinguish pre-learned discrimination performance of fast amplitude modulated tones
Manfred Depner, Konstantin Tziridis, Holger Schulze
- T18-4C** Electrophysiological evidence for auditory motion-detectors in humans
Ramona Grzeschik, Martin Böckmann-Barthel, Roland Mühler, Jesko L. Verhey, Michael B. Hoffmann
- T18-5C** Activity dependent regulation adjusts the duration of inhibition in an echo suppression circuit
Julian Ammer, Felix Felmy
- T18-6C** Calcium entry sites of neurons in the medial superior olive
Felix Felmy, Sarah Berner, Delwen Franzen, Susanne Blank, Christian Kellner
- T18-7C** Variability of Sound Source Position and Temporal Feature Representation in Across-Frequency Integrating Neurons of the Barn Owl.
Philipp Tellers, Kerstin Bülles, Hermann Wagner
- T18-8C** NMDA-dependent enhancement of rate coding in the auditory brainstem.
Ida Siveke, Julian Ammer, Benedikt Grothe, Felix Felmy
- T18-9C** Investigating adaptation in the barn owl with a double-stimulus paradigm: a behavioral approach
Lutz Kettler, Sandra Brill, Dana Zähringer, Hermann Wagner
- T18-10C** Levels of GAP-43 mRNA Reflect Modified Stimulation-Dependent Activity in the Auditory Brainstem of Rats
Nicole Rosskothén-Kuhl, Ralf Birkenhäger, Robert-Benjamin Illing, Robert-Benjamin Illing
- T18-11C** Inhibitory synapses in the developing auditory brainstem transiently release zinc which elicits postsynaptic calcium responses
Elisabet Garcia-Pino, Maria E. Rubio, Catherine J. Weisz, Kandler Karl
- T18-12C** Auditory Input to Tegmental Neurons and its Modulation by Striatal Activity
Anna C. Schneider, Wolfgang Walkowiak
- T18-1D** GABA_B receptor mediated adaptation in medial superior olive neurons
Annette Stange, Andrea Lingner, Michael H Myoga, Felix Felmy, Ida Siveke, Michael Pecka, Benedikt Grothe
- T18-2D** Interaural coherence as a basis for a robust and efficient sound localization model.
Tom Goeckel, Hermann Wagner, Gerhard Lakemeyer

- T18-3D** Role of auditory interhemispheric connections in lateralized sound processing by Mongolian gerbils
Katja Saldeitis, Marcus Jeschke, Max F. K. Happel, Wolfram Wetzel, Henning Scheich, Frank W. Ohl, Eike Budinger
- T18-4D** The claustrum in the Mongolian gerbil (*Meriones unguiculatus*): Architecture and connections with primary sensory and frontal association cortices
Julia Henschke, Eike Budinger, Henning Scheich, Susanne Radtke-Schuller
- T18-5D** Determination of pure-tone hearing thresholds in Eurasian otters (*Lutra lutra*) using brainstem auditory evoked potentials (BAEP)
Mathias Benjamin Voigt, Christian Hackenbroich, Hans-Heinrich Krüger, Arne Liebau, Karl-Heinz Esser
- T18-6D** Hearing during aging in the emerging primate brain aging model *Microcebus murinus*: a BERA study
Christian Schopf, Elke Zimmermann, Julia Tünsmeier, Sabine B.R. Kästner, Andrej Kral
- T18-7D** Change of theta-band coherence between auditory cortex and ventral striatum in Mongolian gerbil during a two-way Go/NoGo operant conditioning task.
Andreas L Schulz, Marie L Woldeit, Frank W Ohl
- T18-8D** Spatio-temporal coding in the bat auditory midbrain and cortex: a representation of echo-acoustic flow?
Uwe Firzlaff, Susanne Hoffmann, Alexander Warmbold, Lutz Wiegrebe
- T18-9D** Amplitude-modulation detection of Gerbils in reverberant sound fields
Lutz Wiegrebe, Andrea Lingner, Kathrin Kugler, Benedikt Grothe
- T18-10D** Projection Patterns of Neurons within the Chicken Inferior Colliculus into Formatio Reticularis and Optic Tectum
Bertram Niederleitner, Harald Luksch
- T18-11D** Metabolic Maturation of Auditory Neurones in the Superior Olivary Complex: Immunohistochemical Study and Mathematical Modelling
Lars Kunz, Barbara Trattner, Céline Marie Gravot, Benedikt Grothe
- T18-12D** Lack of brain-derived neurotrophic factor in the cochlea but not in the brain hampers inner hair cell synapse physiology, but protects against noise induced afferent fiber loss.
Wibke Singer, Annalisa Zuccotti, Stephanie Kuhn, Stuart L. Johnson, Christoph Franz, Dietmar Hecker, Hyun-Soon Geisler, Iris Köpschall, Karin Rohbock, Katja Gutsche, Julia Dlugaiczyk, Bernhard Schick, Walter Marcotti, Lukas Rüttiger, Thomas Schimmang, Marlies Knipper

Coincident inputs achieved by systematic variations of conduction velocity

Armin Harry Seidl, Edwin W Rubel^{1,2}, Andres Barria³

¹Virginia Merrill Bloedel Hearing Research Center, University of Washington, 98195 Seattle, USA

²Department of Otolaryngology – Head and Neck Surgery, University of Washington, 98195 Seattle, USA

³Department of Physiology and Biophysics, University of Washington, University of Washington, 98195 Seattle, USA

Proper function of brain circuitry relies on the exact timing of signal propagation. In the avian brainstem, the circuit responsible for sound segregation consists of internal axonal delay lines innervating an array of coincidence detector neurons that encode interaural time differences (ITDs). Information from the ears gets transferred to nucleus magnocellularis (NM) neurons on each side of the brainstem and individual NM axons project to the dorsal dendritic region of the ipsilateral nucleus laminaris (NL) and to the ventral region of the contralateral NL, resulting in NL neurons receiving segregated input from both ears. These pathways are thought to represent a circuit similar to the Jeffress Model of sound localization. This model assumes equivalent delays from the two ears when a stimulus originates from straight ahead, leading to ITDs of less than 10 μ s. To accomplish this, action potential (AP) speed and travel distance have to be timed precisely - in the microsecond range - to ensure coincident arrival of information at individual detector neurons in NL.

We previously reported that internode distance and axon diameter of NM neurons vary systematically within individual axons to compensate for axonal length differences, suggesting that conduction velocities of specific axon segments are precisely regulated; shorter axon segments should propagate APs slower than longer axon segments.

In the current study, conduction velocities in different NM axon segments were measured. To this end, we recorded from single NM neurons in whole-cell current-clamp mode and determined the difference in the travel time of antidromic APs, elicited at two different locations along the axon. The axons were visualized with biocytin, and with the axon segment length between the stimulation sites conduction times were determined.

Our results show that longer contralateral axons projecting across the midline conduct APs faster than the shorter axons in the ipsilateral loop. Conduction velocities calculated for physiological temperatures and axon length measurements show that conduction times of the ipsilateral and the contralateral NM axon branch are almost equal, leading to coincident arrival of inputs at NL when ITD is 0.

These combined anatomical and functional properties lead to the arrival of appropriately timed binaural inputs to coincidence detector neurons. Conduction velocity is systematically regulated within two different branches of the same axon and the parameters responsible for conduction velocity of NM axons must be regulated precisely during development to achieve coincidence detection.

Masking Release due to Coherent Envelope Fluctuations across Frequency at the level of the Inferior Colliculus

Jan-Philipp Diepenbrock, Frank W. Ohl¹, Jesko L. Verhey²

¹LIN – Leibniz Institute for Neurobiology, Magdeburg, Germany

²Department of Experimental Audiology, University of Magdeburg, Germany

Many natural sounds including speech contain coherent level fluctuations in different frequency bands. A psychoacoustical phenomenon associated with the ability of the auditory system to use this characteristic is comodulation masking release (CMR). The physiological mechanisms underlying CMR is still unclear. The present study uses a typical CMR paradigm, where a tonal signal is embedded in a masker with a spectral component at the signal frequency and one or more off-frequency components. The psychoacoustical CMR describes the effect of a reduced masking when the masker components showed coherent level fluctuations (comodulated condition, CM) compared to a condition where the level fluctuations were incoherent (uncorrelated condition, UN) or to a condition where the masker consisted of the on-frequency component only (the so called reference condition, RF). The present study uses sinusoidally modulated tones as masker components, one centred at the best frequency of the unit and the other positioned into the inhibitory sidebands of the unit. The recording was done in the inferior colliculus of the gerbil. 53 units in 17 animals were tested.

Preliminary analysis on the current data base shows that 25% of units that can follow the amplitude modulation showed a behaviour that is consistent with the hypothesis of wideband inhibition, the hypothesized physiological mechanism underlying CMR from previous studies at the level of the cochlear nucleus. 20% of these units showed a reduction of the representation of the masker modulation due to the presence of the signal, i.e., envelope locking suppression which is another hypothesized physiological mechanism. This mechanism was proposed on the basis of cortical recordings. Since both effects are found at the level of the IC it is possible that the auditory system uses a combination of both leading to a further enhancement of signal detectability.

The role of GABAergic and glycinergic inhibition in shaping SSA in the inferior colliculus of the anesthetized rat.

Yaneri A. Ayala, Manuel S. Malmierca^{1,2}

¹Institute of Neuroscience of Castilla y Leon, Auditory Neurophysiology. ²The Medical School. University of Salamanca, Spain. Pintor Fernando Gallego 1, 37007. Salamanca, Spain

Deviancy detection in the continuous flow of sensory information into the central nervous system is of vital importance for animals. Recently, the neuronal principles of auditory deviance detection have been approached by studying the phenomenon of stimulus-specific adaptation (SSA). SSA is a reduction in the neuronal responsiveness to a common or repetitive sound while the neuron remains highly sensitive to a deviant sound (Ulanovsky et al., *Nature*, 2003). This single-neuron level phenomenon could enhance the saliency of unexpected stimuli against a background of redundant signals. Previous work from our laboratory has shown that adaptation to the repetitive stimulus still occurred in the absence of GABA_A function and that the GABA_A-mediated inhibition could be acting as a gain control mechanism that enhances SSA by controlling the neuron's gain and responsiveness (Pérez-González et al., *PLoS One*, 2012). Since the inhibitory neurotransmission in the inferior colliculus (IC) is mediated by GABAergic and glycinergic receptors, we test whether inhibitory mechanisms other than those GABA_A-mediated contribute to the generation and/or modulation of SSA in the IC of rats. For this purpose, antagonists of GABA_A-, GABA_B- and glycinergic receptors (gabazine, CGP-35348 and strychnine, respectively) were applied microiontophoretically while recording single-unit activity under an oddball paradigm. The responses to high- and low-probability tones were recorded before, during and after the drug injection using an assembly of microelectrodes in a 'piggy-back' configuration. The experimental stimuli were pure tones in the range 0.5–40 kHz, with a 75 ms duration and presented at a repetition rate of 4 Hz. Additionally, the frequency response area (FRA) of the neuron, i.e., the combination of frequencies and intensities capable of evoking a response, was also recorded before and during the blockade of the inhibitory inputs. So far, we recorded the extracellular activity of 30 single units. The co-application of gabazine and CGP-35348 increased spontaneous activity and altered the tuning of the FRAs and the rate-level functions at the best frequency, although the magnitude of the effect was higher under gabazine. The CGP-35348 alone mostly affected only the firing rate rather than the width of the FRAs. The blockade of the three different receptors independently increased the response magnitude to high and low probability stimuli, prolonged the time course of adaptation and caused a reduction of the first spike latency. Application of CGP-35348 alone had only a weak effect on SSA. However, when combined with gabazine and/or strychnine the effects were more profound than each drug alone and resulted in a significant reduction of SSA. Our data indicates a synergic action of GABAergic and glycinergic inhibition in shaping SSA at the IC level and that the blockade of inhibition eliminates the deviant sensitivity of a set of IC neurons suggesting that the SSA observed in those neurons is generated locally.

Supported by the Spanish MICINN (BFU2009-07286), (EUI2009-04083) to MSM.

DIFFERENTIAL EXPERIENCE-DEPENDENT PLASTICITY IN MOUSE INFERIOR COLLICULUS DEPENDING ON PRIOR EXPOSURE.

Hugo Cruces-Solis, Livia de Hoz¹

¹Max Planck Institute for Experimental Medicine, Herman-Rein Strasse 3, 37075 Göttingen, Germany

²International Max Planck Research School for Neurosciences, Göttingen Graduate School for Neurosciences and Molecular Biosciences, 37077 Göttingen, Germany.

Prior work from our group has shown that previously learned expectations modulate the plastic changes that occur in the auditory cortex of mice upon conditioning. Here, to test whether previous experience also affects the processing of sensory information at sub-cortical level, we investigated how the plastic changes elicited by auditory conditioning are affected by prior experience in the inferior colliculus (IC) of mice.

To manipulate the experience mice have before conditioning begins, we pre-exposed the mice to the conditioned tone without reinforcement before the actual conditioning begun (latent-inhibition group, LI). Control mice were pre-exposed to a different tone (no-LI group). In auditory cortex, evoked local field potentials (LFPs) responses to the conditioned frequency were enhanced in the no-LI group in a frequency-specific manner as is to be expected. In the group pre-exposed to the conditioned frequency (LI group), however, the evoked responses were larger to all frequencies tested. Multi-unit activity recordings, on the other hand, showed reduced activity in the LI group. Overall, these results indicate that the experience an animal has accumulated before conditioning begins modulates the pattern of conditioning-induced plasticity.

In the present study, mice were trained in a LI task in a similar manner. Behavioral testing was carried out in a home cage that allows continuous monitoring of the behavior (Audiobox, TSE) by means of a transponder inserted into each mouse. Water was available in a specialized corner after a nose-poke. Visits to the corner were accompanied by the presentation of tone pips. During the habituation phase, mice were exposed to a safe tone whenever they made a visit. In the pre-exposure phase, mice were divided in two groups. The first group was pre-exposed to the safe tone and another, lower, frequency (no-LI group), while the second group was pre-exposed to the safe tone and another, higher, frequency (LI group). Pre-exposure tones were played in 17% of the visits. During the conditioned phase, all the mice were exposed to the higher, now conditioned, frequency in 50% of the visits. The tone was paired with a 1 second air-puff if the mouse made a nose-poke.

We recorded LFPs from the IC of mice before and after conditioning. During the habituation phase, we found a reduced response that was specific to the safe tone, even in mice that had gone through 7 days or more of habituation. In addition, we found differences in the evoked LFPs between no-LI and LI groups upon conditioning, as we did previously in the auditory cortex.

Our results show that learned expectations can also modulate plasticity in the inferior colliculus, suggesting that expectations might play an important role in the processing of ascending sensory information. Whether this effect is dependent on corticofugal input is yet to be determined.

Tinnitus related plasticity in auditory cortex of Mongolian gerbils

Sönke Ahlf, Konstantin Tziridis¹, Holger Schulze¹

¹University Hospital Erlangen, Otorhinolaryngology - Head and Neck Surgery, Experimental Otorhinolaryngology, Waldstr. 1, 91054 Erlangen, Germany

Perception of sound is the result of auditory information processing along the auditory pathway and finally takes place in the auditory cortex. Damages to the auditory receptor epithelium caused by presbycusis, injuries or noise traumata have been shown to result in distorted auditory processing, possibly through malfunctional synaptic transmission (e.g. lateral inhibition). Such functional changes are believed to lead to plastic reorganization of the auditory system that may manifest as tinnitus. Interestingly, not everyone suffering from one of these diseases develops a tinnitus percept and vice versa. The reasons for these individual differences are still unclear and may explain why different treatments of the disease are beneficial for some patients but not for others.

Here we compare behavioral and neurophysiological data from hearing impaired Mongolian gerbils with (T) and without (NT) a tinnitus percept that may elucidate why some specimen do develop subjective tinnitus after noise trauma while others do not. Although noise trauma induced a similar permanent hearing loss in all animals, tinnitus did develop only in about 75% of these animals. NT animals showed higher overall cortical and auditory brainstem activity before noise trauma compared to T animals; that is, animals with low overall neuronal activity in the auditory system seem to be prone to develop tinnitus after noise trauma. Furthermore, T animals showed increased activity of cortical neurons representing the tinnitus frequencies after acoustic trauma, whereas NT animals exhibited an activity decrease at moderate sound intensities by that time. Spontaneous activity was generally increased in T but decreased in NT animals. Plastic changes of tonotopic organization were transient, only seen in T animals and vanished by the time the tinnitus percept became chronic.

We propose a model for tinnitus prevention that points to a global inhibitory mechanism in auditory cortex that may prevent tinnitus genesis in animals with high overall activity in the auditory system, whereas this mechanism seems not potent enough for tinnitus prevention in animals with low overall activity.

This work was funded by the Interdisciplinary Center for Clinical Research at the University Hospital Erlangen (IZKF, Project E7).

Representation of complex sounds in the mammalian inferior colliculus

Dominika Lyzwa, Michael Herrmann²

¹Max-Planck-Institut für Dynamik und
Selbstorganisation, Nichtlineare Dynamik,
Goettingen

² Universität Edinburgh, Informatik, Edinburgh, Schottland

Spectro-temporal neural properties along two different spatial axes within the inferior colliculus in response to complex sound are studied. Vocalizations, being natural stimuli and showing a variety of spectral and temporal modulations are particularly interesting and can elicit responses which are not triggered by artificial simplified sounds.

We study responses from guinea pigs to acoustically presented species-specific vocalizations. Multi-unit activity was simultaneously recorded from 32 positions in the central nucleus of the inferior colliculus (ICC) of guinea pigs using a double shank electrode.

The vocalizations differ in spectral content and envelope shape, ranging from low to broad spectral distributions and from highly periodic to complex envelopes. Responses are characterized with respect to their tuning properties, responsiveness and trial-to-trial spiking variability across the multi-units.

Response preferences to features of the complex sounds depend largely on the characteristic frequency of the neural population, showing e.g. enhanced response for low frequency content and periodic envelopes at low characteristic frequencies.

Post-stimulus time histograms of the neural populations can be predicted to a certain degree by taking into account cochlear frequency band filtering, and the measured tuning curves in the ICC.

Neural discrimination between different vocalizations using linear discriminant analysis yields time windows of 0.5 ms as sufficient to distinguish features of these complex sounds.

Pooling responses from recording sites with different response properties leads to an improved discrimination compared to single-site-based discrimination. Furthermore, it is not decreased when removing temporal correlations by shuffling across trials, which indicates independent encoding schemes.

Only directly neighboring (100 μ m) neural populations respond in a similar manner and have highly correlated PSTHs. Stimulus-driven and intrinsic correlations are compared.

This suggests that complex sounds are encoded efficiently across the tonotopic gradient and that the information from several best frequency laminae is taken into account for complex sound representation.

Fast and Differential Steroid Modulation of the Audio-Motor Integration in the Midbrain of the Toad *Bombina orientalis*

Christof Legler, Wolfgang Walkowiak¹

¹University of Cologne Biocenter, Department of Animal Physiology, Zùlpicher Strasse 47b, 50674 Cologne, Germany

Acoustic communication is the primary mediator of synchronized reproductive behaviour in frogs and toads (anurans). During the breeding season the most relevant acoustic signal is the male advertisement call. The regulation of calling strongly depends on the hormonal state of the animal (e.g., modified by seasonal and diurnal influences, and social context). In most species conspecific calls elicit phonotaxis in females and/or vocal response in opponent males.

The integration of the auditory system and the motor networks is essential for evoked phonotactic or vocal responses to calls. One major structure for audio-motor integration is the torus semicircularis (TS, homolog of the mammalian inferior colliculus)¹. The TS receives ascending auditory inputs from the medulla and, in turn, projects extensively to medullary premotor and motor areas. The main output structure of the TS is the Nucleus laminaris (TL). The TL appears to be the primary target for modulation by forebrain, midbrain, and medullary areas (e.g., striatum, dorsal thalamus, raphe nuclei). GABA, dopamine, serotonin etc. tune the TL network. Moreover, TL neurons were found to express estrogen and androgen receptors². Shaping of neuronal responsiveness in the TL may contribute to selection of motor programs³.

In order to shed light on the mechanism that underlies the modulation of this audio-motor interface by steroid hormones we examined the effect of estrogen (17-beta-estradiol) on intrinsic and synaptic properties of single TL neurons in the Chinese fire-bellied toad (*Bombina orientalis*). We conducted whole-cell patch-clamp experiments in acute para-sagittal brain slices and mimicked auditory synaptic input by stimulating the lateral lemniscus (LL). Estradiol was systemically applied while neurons were kept at different conditions: (i) membrane potential right below firing threshold, (ii) at hyperpolarised level mimicking inhibition, and (iii) while serotonin treatment.

(i) We found that estradiol has fast and differential effects on the firing pattern, the membrane properties, and the synaptic input of TL neurons.

(ii) Estradiol acts against the inhibition like hyperpolarisation.

(iii) The effects of estradiol compete with inhibitory effects of serotonin on firing rate and membrane properties.

1. Walkowiak, W. & Luksch, H. Sensory Motor Interfacing in Acoustic Behavior of Anurans. *Amer. Zool.* 34, 685–695 (1994).
2. Chakraborty, M. & Burmeister, S. S. Sexually dimorphic androgen and estrogen receptor mRNA expression in the brain of túngara frogs. *Horm Behav* 58, 619–627 (2010).
3. Endepols, H., Walkowiak, W. & Luksch, H. Chemoarchitecture of the anuran auditory midbrain. *Brain Res Brain Res Rev* 33, 179–198 (2000).

Influence of Synaptic Inhibition on Output Rate and Timing in a Spherical Bushy Cell Model

Thomas Künzel, Jana Nerlich², Ivan Milenkovic², Hermann Wagner¹

¹RWTH Aachen University, Institute for Biology II, Department of Zoology/Animal Physiology, Lukasstrasse 1, 52070 Aachen, Germany

²University of Leipzig, Faculty of Biosciences, Pharmacy and Psychology, Talstrasse 33, 04103 Leipzig, Germany

Low-frequency spherical bushy cells (SBC) of the anteroventral cochlear nucleus receive powerful axosomatic excitatory input from the auditory nerve via the Endbulb of Held synapse. Morphological and biophysical specializations allow high firing rates while maintaining exquisite temporal precision. However, in-vivo studies suggest a strong influence of inhibitory inputs on the coding function of SBC. Through a dynamic increase in threshold, stronger inputs which are temporally most precise, are preferentially selected. Dependent on stimulus conditions, this results in a dynamic trade-off between output spike rate and temporal precision in SBC in vivo. One proximal consequence is a non-monotonic increase of firing rates upon increasing stimulus intensity.

In this study we explored the interaction of excitatory and inhibitory synaptic inputs in a model of gerbil SBC. The synaptic inputs were modeled as conductance sources on the somatic compartment of the model SBC. The waveform template of the excitatory conductance was fitted to endbulb EPSPs recorded from SBC in anesthetized gerbils in vivo. The waveform of the inhibitory conductance was fitted to glycinergic/GABAergic currents recorded from SBC in acute gerbil brain slices. Spike arrival times of spontaneous and acoustically driven auditory nerve events are used as input to allow a functional evaluation of model performance.

Responses of the SBC model confirm that inhibitory inputs can cause a decrease of output rates in an input-rate dependent manner, to a point of reducing the output back to or even below spontaneous rates. The inhibitory conductance and time-course necessary for this effect were explored in the model. We found that they lie well within the range of values measured in SBC in acute brain slices. Influence of short term plasticity of the inhibitory synapses was also explored in silico. Furthermore, our data showed that stronger excitatory inputs caused least temporal jitter in the model. This was true in the absence, but also in the presence of random membrane noise. In congruence with in-vivo data, interaction of inhibitory and excitatory inputs of a given strength therefore reduced the temporal variability of the SBC output in silico.

Thus, these modeling results corroborate our observations from in-vivo recordings, that the inhibitory inputs can strongly shape the rate and precision of the SBC's output.

Distribution of extracellular matrix proteoglycans at the calyx of Held/principal neurons in the medial nucleus of trapezoid body in mice

Maren Blosa, Mandy Sonntag², Gudrun Seeger¹, Rudolf Rübsamen², Thomas Arendt¹, Markus Morawski^{1,3}

¹Paul Flechsig Institute for Brain Research, Department of Molecular and Cellular Mechanisms of Neurodegeneration, Jahnallee 59, 04109 Leipzig, Germany

²Institute of Biology II, Faculty of Bioscience, Pharmacy, and Psychology, University of Leipzig, Talstr. 33, 04103 Leipzig, Germany

³Department of Neuroscience and Physiology, State University of New York Upstate Medical University, Syracuse, NY 13210, USA

The extracellular matrix is enriched in the extracellular space around neurons and glia. Some neurons exhibit a specialized form of extracellular matrix, which is condensed at the soma, dendrites and axoninitialsegment, called perineuronal net (PN). PNs are characterized by a special composition that consists of chondroitinsulfate proteoglycans, hyaluronan, link proteins and tenascin-R. The PNs are supposed to be involved in neuronal communication, stabilization of synaptic contacts and considered to protect neurons and synapses.

In the medial nucleus of the trapezoid body (MNTB) every neuron is surrounded by a PN. Furthermore the MNTB is an essential structure for sound localization in the auditory system and bears a unique component, the calyx of Held. Each principal cell of the MNTB is contacted by this excitatory giant axosomatic terminal which provides a precise transmission of auditory information.

Here we give a detailed insight in the distribution of PN-components in the MNTB. Our findings implicate precise evidences for physiological functions of PNs and form a basis for further fundamental investigations.

Roles of GABA-mediated inhibition in the cortical processing of temporally-patterned sounds

Julio C. Hechavarria, Manfred Kössl¹

¹Institute for Cell Biology and Neuroscience, University of Frankfurt, Frankfurt/Main 60438, Germany.

Echolocating bats use the time elapsed from biosonar pulse emission to the arrival of echo (defined as echo-delay) to infer target-distance. In the auditory cortex, echo-delay is encoded by delay-tuned neurons that respond to pulse-echo pairs presented at specific delays. Delay-tuned neurons belong to the group of so-called “combination-sensitive neurons” that are thoroughly documented filters in vertebrates. A substrate for delay-tuning is not present at the level of the sensory epithelia (i.e. the cochlea) and therefore this type of tuning is created *de novo* in the central auditory system, through interplay of excitation and inhibition. We investigated roles of γ -Aminobutyric acid (GABA) inhibition in the cortical processing of pulse-echo delay in bats. Roles of GABA in the cortex remain largely unknown, particularly when it comes to selectivity types implemented *de novo* in central neurons as it is the case of delay-tuning. The presence of inhibition in cortical responses was assessed both directly and indirectly. Indirect methods involved the analysis of extracellularly recorded response patterns to single and paired FM-sweeps. Direct methods involved the blocking of GABAergic receptors in delay-tuned neurons using the GABA_A receptor antagonist bicuculline. Our results show strong evidence for inhibition in the response of cortical delay-tuned neurons. In all 122 studied neurons the comparison of responses to paired and single FM-sweeps revealed that strong inhibition occurs at non-preferred delays. Also, 41% of delay-tuned neurons display longer response latency to loud sounds than to faint sounds. This response feature is defined as paradoxical latency shift and it is known to be created by high-level inhibition of long-lasting responses. In 77% of delay-tuned neurons “amplitude-tuning” was found. Amplitude-tuning too relies on high-level inhibition of responses. The application of bicuculline on delay-tuned neurons revealed that only a small fraction of the inhibition observed in extracellularly-recorded responses is of cortical origin. Iontophoresis of bicuculline removed delay-tuning in only 18% of neurons. In those neurons, delay tuning is created *de novo* in the cortex and GABA plays a critical role on its implementation. In the majority of studied neurons GABA did not remove delay tuning but it did increase response bandwidth and more importantly it changed the overall spike-output by as much as tenfold. We propose that cortical GABAergic circuits provide a substrate for modulating the “gain” of neuronal responses in different operating states.

Independent Response Adaptation of Excitatory and Inhibitory Inputs Allows Rapid Adjustment of Optimal Spatial Sensitivity in Lateral Superior Olivary Neurons

Helge Gleiss, Michael Pecka¹, Benedikt Grothe^{1,2}

¹Ludwig-Maximilians-Universität München, Department of Biology II, Division of Neurobiology, Großhaderner Str. 2, 82152 Martinsried, Germany

²IFB^{LMU} Deutsches Schwindelzentrum, Munich, Germany

The ability to localize a sound source in noisy, fluctuating environments is crucial to everyday life. It is therefore important that sound localization circuitry can adapt its sensitivity and gain on rapid time scales. Generally, the location of a sound source can be determined via the detection of interaural level differences (ILDs), which are created by the shadowing effect of the head and ears. ILDs are first encoded by neurons of the Lateral Superior Olive (LSO) by comparing excitatory input from the ipsilateral ear with inhibitory input from the contralateral ear. Thus, the balancing of excitatory and inhibitory input strength and timing is crucial for maintaining high spatial sensitivity in LSO neurons. However, it is unknown how this balance in the LSO is influenced by rapid changes in ILD. Specifically, a detailed knowledge of the response adaptation of excitatory and inhibitory inputs is crucial to better understand the neuronal mechanisms underlying sound localization in dynamic environments.

Here, we characterize the specific properties of response adaptation in the excitatory and inhibitory inputs to the LSO separately by presented stimuli of different sound level distributions to the two ears while performing extracellular single cell recordings in the LSO of anaesthetized Mongolian gerbils (*Meriones unguiculatus*). Stimuli consisted of white noise presented at rapidly changing sound levels (high variability) to one ear while presenting the identical white noise at a constant sound level (low variability) to the other ear. Moreover, to examine the temporal properties of response adaptation in the respective inputs, the average sound level was abruptly switched in either one or both ears in a periodic manner.

We find that in young adult animals (~90 days old), LSO neurons exhibit pronounced response rate adaptation that depends on the average level and/or variability presented in either ear. The ILDs that created a balance of input strength and timing between excitation and inhibition were significantly shifted in dependence of the variability of the stimuli in each ear. Response adaptation was apparent already within tens of milliseconds following changes in the average sound level. Additionally, neurons showed a second, slower time constant of rate adaptation at the level of seconds. Interestingly, sound localization acuity diminishes with age. In future experiments, we will examine response adaptation in aged animals (>2.5 years old), which will provide insight into the circuit mechanisms that underlie age-dependent changes in ILD processing.

Together, our results suggest that the balance of excitatory and inhibitory inputs in LSO neurons is adjusted dynamically and rapidly. Thus, fast computation of temporary ILDs might be a prerequisite of LSO neurons to allow for faithful sound localization in dynamic environments.

Adaptation in the auditory midbrain of the barn owl induced by three double stimulation paradigms

Roland Ferger, Martin Singheiser¹, Philipp Tellers¹, Mark von Campenhausen¹,
Hermann Wagner¹

¹Institute for Biology II, RWTH Aachen, Department of Zoology and Animal Physiology, Mies-van-der-Rohe-Straße 15, 52056 Aachen, Germany

The barn owl (*Tyto alba*) as a nocturnal hunter is a specialist in sound localization. The main binaural cues the owl utilizes for sound localization are the interaural time difference (ITD) and the interaural level difference (ILD). The primary processing of those cues is done in the auditory midbrain, particularly in the inferior colliculus (IC). The neurons in this region like most neurons in the auditory system exhibit adaptation in various aspects. They typically respond with a high rate to the onset of an acoustic stimulus and this rate decreases to a plateau or steady state during ongoing stimulation. This decline in firing rate is termed spike-frequency adaptation. Another type of adaptation can be shown with two subsequent stimuli. When a first excitatory stimulus (masker) is presented before a second stimulus (probe) the mean response rate to the probe is reduced compared to when the probe is presented alone. We call the relation of response rates to the probe and the masker "response ratio" where response ratios below unity denote a reduced response rate.

In this study we investigated adaptation to acoustic stimuli with extracellular recordings from neurons in the barn owl's midbrain. The stimuli (100ms duration, each with 5ms ramps) were presented with earphones placed in front of the owl's ear canals. This gave us control over the ITD and ILD of the presented stimuli. We could show earlier that in both the central nucleus of the IC (ICC) and the external nucleus of the IC (ICX) neurons exhibit response adaptation when stimulation was done with appropriate stimuli. Therefore, stimulation was done with pure tones at the best frequency for ICC neurons and with broadband noise for ICX neurons. Here we show the comparison of those results.

In a first double stimulus paradigm we investigated the recovery time of the neurons, i.e. the inter-stimulus interval (ISI) needed to obtain equal response rates to masker and probe. ISIs from 0ms to 1600ms on a quasi-log₂-scale were tested. Masker and probe had identical binaural cues and the same level which was set to drive 50% of the maximum response rate as determined by a rate-level function (RLF) for each unit. In the ICC response ratios were significantly below unity for ISIs up to 400ms whereas in the ICX an ISI of 100ms was sufficient to obtain equal response rates for masker and probe.

In another double stimulus paradigm masker and probe were presented with an ISI of 0ms and the probe's level was varied from equally to that of the masker (2nd level 0dB) to 25dB louder (2nd level 25dB) in 5 dB steps. Masker level was at 50% of the RLF. An increase of only 5dB resulted in response ratios of one in ICC and ICX. The further increase of 2nd level elicited even higher response rates to the probe.

A third double stimulus paradigm was only applied to ICX. While the ISI was 0ms and the 2nd level 0dB the ITD of masker and probe was different. The masker was presented at the ITD eliciting maximal response (best ITD) and the probe's ITD (2nd ITD) was varied along the physiological range. The resulting 2nd ITD response curve was compared to a normal ITD response curve. Consistently with the previous findings the response ratio was below one when 2nd ITD = best ITD. A shift of the best ITD

could not be observed. The responses to 2nd ITDs beside the best ITD show a decreased rate, too. This could implicate that adaptation is not stimulus specific at this state.

Regularity-dependent changes in stimulus-specific adaptation in the auditory cortex

Sebastian Florian Betz, Bernhard H. Gaese¹

¹Goethe Universität Frankfurt, Institute for Cell Biology and Neuroscience, Max-von-Laue Straße 13, 60438 Frankfurt am Main, Germany

Most studies on stimulus-specific adaptation (SSA) in the auditory domain so far used a fixed pattern with a constant rate of stimulus presentation for standard and deviant stimuli. However, noises and other acoustic signals in the daily environment are continuously occurring in variable temporal patterns. Therefore, new paradigms were tested to reveal the possibly complex temporal aspects of SSA in cortical neurons. Either rhythm-like patterns with a regular repetition rate or different inter-stimulus intervals for standard and deviant stimuli were used in several oddball paradigm experiments. This should reveal if neurons in the auditory cortex show SSA depending on temporal regularity.

As before, we used oddball paradigms to look for differences in firing rates between responses to frequently occurring standard stimuli and rarely occurring deviants. Extracellular recordings in the primary auditory cortex (A1) while using these stimulus paradigms were tested in the brains of four rats. They underwent surgery for permanent implanting of electrodes in the auditory cortex. Custom-build microdrive implants (electrodes attached) were inserted to alter the electrode depth in order to penetrate the auditory cortex tangentially in several layers. All experiments were performed while the animals were fully awake sitting in a sound-proven anechoic chamber. After finishing all electrophysiological measurements histological staining of each rat brain was required to confirm the location of the electrodes in the auditory cortex.

The recordings showed that a basic oddball paradigm with a frequency difference between standard and deviant elicited strong SSA in the auditory cortex. Activity to deviant responses was significantly increased compared to standard responses. The level of SSA introduced by frequency separation (0.5 octaves) did not change depending on temporal regularity – deviant responses with shorter or longer inter-stimulus intervals were neither increased nor decreased compared to unchanged inter-stimulus intervals. However, if only the regularity parameter was altered, deviant responses were decreased in one paradigm. Shortened inter-stimulus intervals (300 ms) before each deviant caused a decreased ON response in deviants compared to standards. Lengthened intervals (700 ms) caused a very small increase in deviant responses, much smaller than SSA introduced by frequency separation.

Combination of the investigated parameters did not alter the level of SSA towards deviant stimuli. Paradigms using only regularity differences could not even elicit similar responses compared to the classic approach. For inter-stimulus intervals of 300 ms the local habituation effects dominated overt SSA-dependent response changes that would have caused an increase. Responses to stimulation with all other intervals > 500 ms followed more or less the rules of novelty detection (global effects) and thereby increased neuronal activity when deviant tones were presented. The next step to reveal more temporal properties of SSA in the auditory cortex will be to randomly alter the interstimulus intervals between standards and deviants. This should finally reveal if SSA can still be maintained under these (more natural) conditions.

Rat auditory cortical functioning and different aspects of performance in frequency discrimination tasks

Ann-Kathrin Riegel, Bernhard H. Gaese¹

¹Goethe Universität Frankfurt, Institute for Cell Biology and Neuroscience, Max-von-Laue-Straße 13, 60438 Frankfurt/Main, Germany

The functional significance of the auditory cortex for frequency discrimination was shown in several studies. There were, however, only few studies investigating the importance of this structure for basic frequency discrimination in respect to other abilities like categorization or knowledge transfer between different tasks. This study, therefore, focused on two different aspects: On the one hand on behavioral effects of inactivation of the auditory cortex in frequency discrimination tasks, and on the other hand on the ability of rats to categorize different sound properties and to transfer this ability to other tasks.

All animals were trained in a 2-alternative-forced-choice (2AFC) paradigm to discriminate between a pure tone and a narrow band noise stimulus in the same frequency range. Subsequently, the animals were divided into two groups: The inactivation and the behavior group.

Animals in the inactivation group were implanted bilaterally with a guide cannula in the primary auditory cortex. After a short retraining phase the auditory cortex of the animals was temporarily inactivated with several doses of lidocaine. The temporal development of behavioral effects was observed with high resolution after the injection, comparing task performance (fault rates) and reaction times. The results of the inactivation experiments revealed higher reaction times after the injection of lidocaine. However, a dose dependency of these effects or a change in the fault rates could not be observed.

For the animals of the behavior group the training paradigm was varied to investigate the effects of categorization and transfer learning in different variants of the basic frequency discrimination task. Therefore the pure tone frequency and the center frequency of the 0.5-octave noise band were shifted. Animals were able to transfer their knowledge from the frequency range trained in the basic paradigm to a higher frequency range. Furthermore, the paradigm was easier for the animals if the additional cue of a frequency difference between pure tone and noise was introduced. However, after an alteration of the frequency differences (exchange of the frequency range between pure tone and noise) higher fault rates demonstrate that the task became more difficult for the animals. This indicates that in this case stimulus categorization was superimposed by the effect of frequency difference.

In summary, the experiments revealed that the animals were able to categorize sounds (pure tone, noise band), but that differences in frequency can serve as even stronger cues for discrimination. Furthermore, the ability for sound categorization can be partly impaired after a temporal inactivation of the auditory cortex. So we were able to link sound discrimination to functioning of the primary auditory cortex. How more cognitive abilities such as putting sounds into different categories or transferring discrimination knowledge to different variants of a task are also directly related to auditory cortical functioning are still open. This requires further investigations that make use of the combination of specific short-term inactivation of a brain area and behavioral tasks that allow for efficient determination of performance at a fairly high temporal resolution.

Hyperpolarization-activated currents shape temporal response properties in mouse superior paraolivary nucleus neurons

Katrin Vonderschen, Anna K. Magnusson¹

¹Karolinska Institute, Center for Hearing and Communication Research, M1:00-ENT Karolinska Hospital (Solna), 17176 Stockholm, Sweden

The temporal structure of slow sound level fluctuations is an important cue for the perception of complex acoustic stimuli. For instance, perception of human speech relies heavily on accurate processing of the sound envelope. The neuronal mechanisms by which the sound envelope is extracted and conveyed to higher auditory areas are unknown.

The Superior Paraolivary Nucleus (SPON) is a prominent structure in the mammalian auditory brainstem, which is characterized by its ability to fire with high precision to slow sound level fluctuations or sound gaps. Thus, SPON has been implicated in the encoding of the sound envelope structure. In order to accomplish this, SPON neurons are equipped with specific intrinsic membrane properties, such as a rebound spiking mechanism that causes them to fire action potentials upon a preceding hyperpolarization. Presumably, the rebound spiking enhances the neurons' ability to follow sound periodicity, but exactly how the shape and temporal structure of the signal activate the rebound mechanism is unknown.

Here, we use an in vitro approach by injecting a range of periodically modulated synthetic stimuli in current-clamp recordings in combination with pharmacology to investigate how three ion currents, activated in the hyperpolarized voltage range, contribute to the tuning and preferred spiking response of SPON neurons.

Neural coding of target range in bats is influenced by reflections from water surfaces

Alexander Luis Warmbold, Uwe Firzlaff², Lutz Wiegrebe¹

¹Ludwig-Maximilians-Universität München, Division of Neurobiology, Department Biologie II, Großhadernerstraße 2, 82152 Planegg-Martinsried, Germany

²Technische Universität München, Lehrstuhl für Zoologie, Wissenschaftszentrum Weißenstephan für Ernährung, Landnutzung und Umwelt, Liesel-Beckmann-Straße 4, 85354 Freising-Weißenstephan, Germany

Microchiropteran bats emit ultrasonic sounds and listen to the returning echoes to locate and identify prey or obstacles. Siemers et al. (2005) showed that bats have a higher success rate perceiving prey above water surfaces compared to perceiving prey in mid air. Water bodies present the only surface in nature that is smooth enough to serve as an acoustic mirror. Due to the high directionality of the echolocation system, most of the call energy hitting the water surface is reflected away from the bat. Only the minor part of call energy is reflected orthogonally towards the bat. Thereby, the clutter a bat normally receives when hunting above rougher surfaces is reduced to a minimum and the signal to noise ratio is increased.

But like optic mirrors acoustic mirrors also can introduce ambiguities, i.e. acoustic mirror images of prey. Therefore it is crucial for bats to adapt to this special situation and perceptually suppress these mirror images.

The aim of our study was to investigate the neural mechanisms that might underlie the suppression of undesired mirror images. As the measurement of target distance by echo delay is crucial for successfully capturing prey, our study design focused on this mechanism. We tested if the best delay (BD) of neurons in the dorsal auditory cortex of the bat *Phyllostomus discolor* is influenced by a preceding echo orthogonally reflected from a water surface below. To this behalf, virtual echoes in space were generated by convolving a standard echolocation call of *P. discolor* with the transfer-functions of hearing and emission. Stimuli consisted of pairs of calls and echoes with different temporal delays (direction 0° elevation, 0° azimuth). Presentation of the call was always 0 – 30 dB louder than the echo. After determining the range of delay tuning and the BD of a neuron, an additional echo from 90° below was introduced, and the BD was determined again for this condition. The echo was presented with a range of delay-steps that were always shorter than the BD.

Preliminary results show an influence of single echoes from water surfaces concerning the delay tuning of a neuron: BDs decreased when an additional faint reflection with short delay was presented. In a behavioral context, this observation makes sense: mirror images of prey items above water surfaces are received with longer delay as the direct reflections (see Figure). The additional water surfaces-specific, orthogonal reflection would shift the BD of a neuron toward the shorter delay of the direct reflection, making the mirror-image 'invisible' to the bat.

The results suggest that the BD of a neuron can be influenced by short term adaption depending on the features of the current complex acoustic scenery.

- This study is supported by the Human Frontier Science Program (RGP0062/2009).
- Reference:
Siemers B, Baur E, Schnitzler HU (2005) Acoustic mirror effect increases prey detection distance in

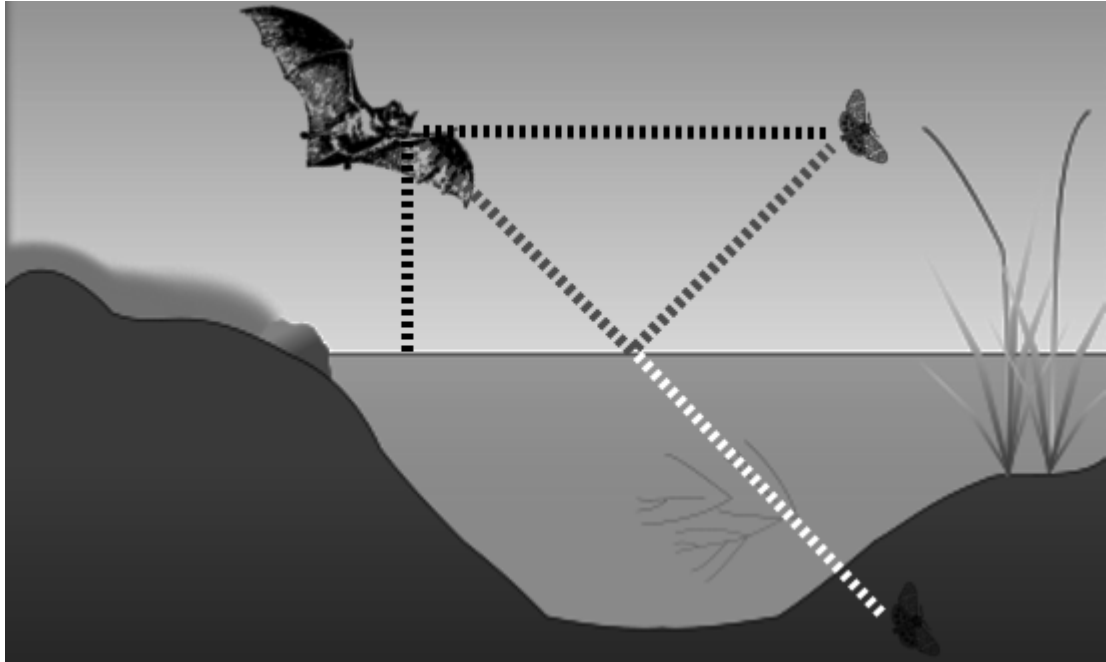

Directionality of hearing in domestic chicken (*Gallus gallus domesticus*)

Hans Andrea Schnyder, Dieter Vanderelst², Sophia Bartenstein¹, Uwe Firzlaff¹, Harald Luksch¹

¹Technische Universität München, Lehrstuhl für Zoologie, Liesel-Beckmann-Straße 4, 85354 Freising, Germany

²University of Antwerp, Active Perception Lab, Antwerp, Belgium²

Sound reaching the eardrum is modified by absorption, reflection and diffraction. These modifications are caused by the head and its associated structures and are described by the head related transfer function (HRTF). HRTFs can be used for presentation of acoustic stimuli in virtual space.

Here we measure the HRTF of the domestic chicken with two different methods. The frequency specific spatial pattern of interaural intensity differences (IIDs) and interaural phase and time differences (IPDs and ITDs) are described as well.

Paraformaldehyde fixated chicken heads (male and female) were positioned centrally in a semi-circular loudspeaker array. The array consisted of 27 speakers (5.625° separation) covering spatial positions between -90° to 90° in azimuth and -73.125° to 73.125° in elevation. Impulse responses (IRs) from different spatial positions were measured by cross-correlating the output signal (white noise, 2 s duration) and the signal recorded with small microphones (Knowles EM-23346 D65) placed near the eardrums. The IRs were compensated for the frequency response of the microphone and the individual speakers. Additionally, we scanned paraformaldehyde fixated chicken heads via x-ray computed tomography and calculated HRTFs using an acoustic free field simulation tool. As expected, the directionality of sound pressure transformation increased substantially with increasing frequency. Below 2 kHz sound pressure was almost uniformly distributed throughout the frontal hemisphere. However, a special situation exists in male chicken. Due to their prominent appendages (comb and throat sac) irregularities occurred in their HRTFs. The frequency specific directional pattern of IPDs is discussed.

The hearing function of the deletion of L-type CaV1.2 in the peripheral and central auditory system

Sze Chim Lee, Annalisa Zuccotti^{1,2}, Somisetty V. Satheesh³, Thomas Schimmang⁴,
Lukas Rüttiger¹, Hans Gerd Nothwang³, Marlies Knipper¹

¹Eberhard Karls Universität Tübingen, Department of Otolaryngology, Head and Neck Surgery, Tübingen Hearing Research Centre, Elfriede-Aulhorn-Strasse 5, 72076 Tübingen, Germany

²Current address: Dept. Clinical Neurobiology of University Hospital and DKFZ Heidelberg, Im Neuenheimer Feld 280, 69120 Heidelberg, Germany

³Department of Neurogenetics, Carl von Ossietzky University Oldenburg, 26111 Oldenburg, Germany

⁴Instituto de Biología y Genética Molecular, Universidad de Valladolid y Consejo Superior de Investigaciones Científicas, 47003 Valladolid, Spain

In a previous study we could show that BDNF in the cochlea is required for normal hearing function. However, BDNF reduction was found out to be protective for IHC and IHC synapse following noise induced acoustic trauma. (Zuccotti et al. 2012). In the brain, BDNF expression is controlled by L-type voltage-gated Ca²⁺ channel 1.2 (CaV1.2) activity at the transcriptional level (West et al., 2001, McDowel et al., 2010). CaV1.2 channel is expressed in spiral ganglion neurons in the auditory system but its regulatory function for BDNF in the cochlea and its effect on hearing is yet unknown.

Constitutive CaV1.2 knockout mice die in utero before embryonal day 15 (Seisenberger et al., 2000). We therefore inactivated CaV1.2 in a conditional mouse line (CaV1.2^{Pax2/Cre}) tissue specifically in the cochlea, dorsal cochlear nucleus and inferior colliculus. Complementarily, we conditionally inactivated CaV1.2 in the olivary complex (MSO/LSO) but not in the cochlea by crossing the CaV1.2^{fl/fl} mouse line with a mouse line expressing Cre under a promotor specifically expressed in the central auditory system (CaV1.2^{Egr2/Cre} Satheesh et al., 2012). For both mouse lines, we compared the hearing thresholds and the waveform fine structure (wave amplitudes, growth function and latencies) of auditory brainstem responses (ABR) before and after noise exposure.

After noise, CaV1.2^{Pax2/Cre} mice had less ABR threshold loss and less reduction in ABR wave I amplitude, similar to what was found for the BDNF^{Pax2} KO mice described before (Zuccotti et al., 2012). However, deletion of CaV1.2 in the auditory brainstem in the CaV1.2^{Egr2/Cre} mouse line did not affect, or protect, hearing function after noise. This suggests that CaV1.2 channel activity and the increase of BDNF may exacerbate damage in the cochlea after noise.

Supported by the Marie Curie Research Training Network CavNET MRTN-CT-2006-035367, Deutsche Forschungsgemeinschaft, grant DFG Kni316/4-1

Frequency-related topography of the corticofugal connections of field AI in the Mongolian gerbil

Eike Budinger, Michael Brosch², Henning Scheich¹, Judith Mylius²

¹Leibniz Institute for Neurobiology, Auditory Learning and Speech, Brenneckstr. 6, 39118 Magdeburg, Germany.

²Leibniz Institute for Neurobiology, Primate Neurobiology, Brenneckstr. 6, 39118 Magdeburg, Germany.

We investigated the frequency-related topography of the connections of the primary auditory cortical field (AI) in the Mongolian gerbil with subcortical structures of the auditory system by means of the axonal transport of two bidirectional tracers. These were simultaneously injected into regions of AI with different best frequency representations (BFs).

We found topographic, most likely frequency-matched (tonotopic) connections as well as non-topographic (non-tonotopic) connections. AI projects in a tonotopic way to the ipsilateral ventral (MGv) and dorsal divisions (MGd) of the medial geniculate body (MGB), reticular thalamic nucleus and dorsal nucleus of the lateral lemniscus as well as to the ipsi- and contralateral central nucleus and dorsal cortex of the inferior colliculus (IC). AI receives tonotopic inputs from MGv and MGd.

Projections from different BF regions of AI terminate in a non-tonotopic way in the ipsilateral medial division of the MGB (MGm), supragenulate thalamic nucleus (SG) and brachium of the IC (bic) as well as in the ipsi- and contralateral external cortex and pericolicular areas of the IC. The anterograde labeling in the intermediate and ventral nucleus of the lateral lemniscus, parts of the superior olivary complex and divisions of the cochlear nucleus was generally sparse, thus no clear topographic arrangement of the labeled axons was evident although conceivable. AI receives non-tonotopic inputs from the ipsilateral MGm, SG and bic.

In conclusion, AI contributes to the tonotopic as well as to the non-tonotopic corticofugal system. Tonotopic connections of AI may serve for a conservation of frequency-specific information in the respective target structures whereas non-tonotopic connections could be involved in frequency-integration processes.

“That’s far below me!” - Pulse-Echo delay sensitivity in the vertical plane measured in the auditory cortex of bats

Susanne Hoffmann, Selina Prosch¹, Uwe Firzlaff², Lutz Wiegrebe¹

¹Ludwig-Maximilians Universität München, Department Biologie II, Grosshaderner Strasse 2, 82152 Planegg-Martinsried, Germany

²Technische Universität München, Lehrstuhl für Zoologie, Liesel-Beckmann-Str. 4, 85350 Freising-Weihenstephan, Germany

Echolocating bats use the temporal delay between emitted pulse and returning echo to determine the distance to a target. Especially when airborne it is important for a bat to analyze pulse-echo delays in the vertical plane to determine the height above the ground and the distance to obstacles in elevation. Neurons, sensitive to certain pulse-echo delays, have been found in the midbrain, thalamus and auditory cortex (AC) of different bat species. So far it is unknown, whether the spatial position of the echo has an influence on the neural coding of target range. This question motivated the present study on the dependency of delay-sensitivity on the vertical position of the echoes.

We measured vertical spatio-temporal receptive fields (SPATRFs) of neurons in the AC of the bat *Phyllostomus discolor*. The SPATRF describes the spatial tuning of a neuron over time and should thus be suited to detect delay sensitivity. SPATRFs were recorded by presenting extended random sequences of echoes in virtual acoustic space to anaesthetized bats. Virtual echoes were generated by convolving a standard echolocation call of *P. discolor* with head-related impulse functions for 23 vertical positions. Extracellular neural responses were continuously recorded during presentation of virtual echoes and used to reconstruct vertical SPATRFs by a reverse correlation technique.

40% (70/177) of tested neurons were considered to be delay sensitive. They showed a specific arrangement of excitatory areas in their SPATRF: one excitatory area with a long latency, which may encode the emitted pulse, was located around 0° in elevation and was followed by spatially and temporally separated excitatory areas with shorter latencies, which may encode the returning echoes. These areas were typically located at lower positions in elevation. In 67% (28/42) of delay-sensitive neurons SPATRFs could be verified with a conventional stimulus paradigm: when presented with a combination of two single virtual stimuli originating from the centers of gravity of the pulse- and echo-encoding excitatory areas neurons showed facilitated responses to combinations with certain temporal delays.

The data shows that auditory cortical neurons in bats encode pulse-echo delay sensitivity in strong dependency on the vertical position of the echo, and therefore specifically process behaviorally relevant information about object position in elevation.

This work was supported by a research grant of the Human Frontier Science Program (RGP0062/2009) and a grant of the Bayerische Gleichstellungsförderung 2010.

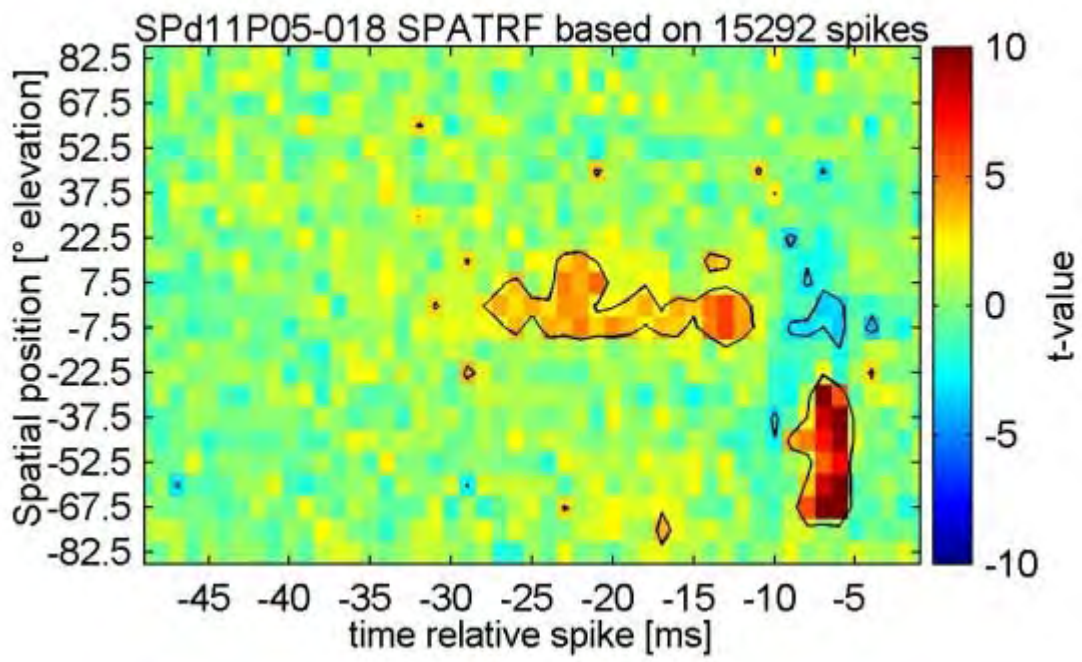

Effects of two different hearing aids on sound processing in the primary auditory cortex of Mongolian gerbils

Konstantin Tziridis, Sönke Ahlf¹, Michael Heiden¹, Holger Schulze¹

¹University Hospital Erlangen, Otorhinolaryngology - Head and Neck Surgery, Experimental Otolaryngology, Waldstrasse 1, 91054 Erlangen, Germany

The impairment of the peripheral auditory system caused, e.g., by acoustic trauma, ongoing noise exposure, mechanical injuries or simply presbycusis leads to hearing deficits in humans that are generally attempted to be compensated by the use of hearing aids (HA) adapted to the individual hearing impairment which is mostly characterized by peripheral or subcortical measurements. Unfortunately, these adjustments often do not lead to “normal” sound and speech perception and the HA is refused by the patient. As the perception of sound is determined by its cortical processing and representation we here examine the effects of two different HA – an older single channel (HA1) and a more advanced six channel device (HA6) - on sound processing in primary auditory cortex of Mongolian gerbils.

Single and multi-units responses to pure tones were recorded in the left auditory cortex of gerbils with and without commercially available HA attached to both ears. In healthy, normal hearing animals we found a strong increase in firing rate in response to pure tones and a shift in the best frequency (BF) reflecting the spectral characteristics of the HA1 when it was switched on. By contrast, hearing impaired animals (acoustic trauma at 2 kHz, 115 dB SPL, 75 min) unexpectedly showed no significantly increased firing rate or shift of the BF but strong changes in characteristic frequency (CF) or neuronal threshold. Contrary to these results, first recordings with the HA6 after the acoustic trauma indicate an increase of evoked spike rate in most hearing impaired animals as well as a shift of BF but no changes in the CF, which is comparable to the results observed in healthy animals.

These results point to a reduced or changed dynamic range of auditory cortical neurons in the hearing impaired animals that cannot be compensated by the HA1 but maybe – at least in part - by the HA6. This may explain the problems reported by many patients with the old-typed single-channel HA; especially the diminished dynamic range between hearing threshold and threshold of pain, which in turn may explain the problems with speech intelligibility in noisy environments.

Glycinergic Inhibition Controls Synaptic Integration in the Medial Superior Olive

Michael Hideki Myoga, Simon Lehnert¹, Christian Leibold¹, Felix Felmy¹, Benedikt Grothe¹

¹Ludwig-Maximilians-Universität München, Department of Biology II, Großhaderner Str. 2, 82152 Planegg-Martinsried, Germany

The brainstem nucleus of the medial superior olive (MSO) encodes differences in the arrival time of sounds between the ears (interaural time difference or ITD), providing information about the location of sounds in the horizontal plane. MSO neurons receive bilateral phase-locked excitation and glycinergic inhibition. MSO neurons integrate all four synaptic inputs, but it is not understood how these inputs interact at the cellular level to generate ITD output functions. Here, we investigated whether the precise timing of inhibition is important for synaptic integration in the MSO.

We performed patch-clamp recordings of MSO neurons in acute slices from adult (postnatal day 60 – 90) Mongolian gerbils (*Meriones unguiculatus*) at near physiological temperature (35 °C). We investigated the interaction between EPSPs and IPSPs using fiber stimulation and conductance-clamp recordings. We also created a computational model of an MSO neuron, based largely on our measured membrane properties.

We first measured excitatory and inhibitory synaptic conductances evoked by putative single presynaptic fibers in voltage-clamp in many neurons. From these data, we selected representative conductance waveforms as templates and then simulated excitatory and inhibitory potentials (EPSPs and IPSPs) in conductance-clamp. We found that the peak of a combined EPSP and IPSP is advanced when the EPSP occurs during the hyperpolarizing phase of an IPSP, but is delayed when the EPSP occurs during the re-depolarizing phase of the IPSP. This suggests that precisely timed inhibition can shift the peak timing of excitation arising from either the ipsilateral or contralateral side. We went on to investigate how the timing of an IPSP influences the summation of two EPSPs. Without inhibition, two EPSPs summated maximally when they occur simultaneously. However, when a pair of EPSPs occurred during the hyperpolarizing phase of the IPSP, maximal summation was observed when the first EPSP led the second. Moreover, when the EPSPs occurred during the re-depolarizing phase of the IPSP, maximal summation was observed when the first EPSP trailed the second. We also used the same conductance templates as inputs for our model simulations and found that if the model quantitatively matches the voltage responses, it provides a good prediction for the effect of inhibition on the peak timing and summation of EPSPs.

Our findings indicate that precisely timed inhibition can influence the coincidence detection of ipsilateral and contralateral excitation. This provides evidence for a crucial role for inhibition in ITD tuning in vivo.

Telemetric study of neuronal activity in a song nucleus HVC reveals one neuron type that is involved in sensory-motor control of calls in zebra finches

Shouwen Ma, Lisa Trost¹, Manfred Gahr^{1,2}, Andries ter Maat¹

¹Max-Planck-Institute for Ornithology, Behavioural Neurobiology, Eberhard-Gwinner-Straße, Haus 6a, 82319 Seewiesen, Germany

²Graduate School of Systemic Neurosciences, Ludwig-Maximilians-Universität München, Großhaderner Str. 2, 82152, Planegg-Martinsried

Zebra finches are social animals that communicate with each other using calls and songs. To facilitate the social communication, a precise mechanism of sensory-motor control is required. Previous studies have shown that song production involves specific forebrain pathways. In contrast to songs, both male and female zebra finches produce calls to communicate within a flock. Calls are the most frequently uttered vocalizations. In song birds, forebrain nuclei are critical for the production of song. But whether the forebrain nuclei also play a role in call communication and if so, what neural mechanisms underlie the sensory-motor control of calls is at present poorly known.

In order to study the role of the song nucleus HVC in vocal communication, we used a wireless telemetric system for simultaneous measurement of neural activity and vocalizations in animals that could freely interact with their mates. In this study, we focused on the firing patterns associated with auditory-vocal processing in HVC. We discovered one type of HVC neuron in males that fired stereotypically when producing calls as well as during processing auditory inputs elicited by female calls. The firing patterns are phase-specific. Only specific time phases are affected by the auditory-vocal interactions.

Our study provides empirical evidence that HVC plays a role in the sensory-motor control of calls. Although the higher vocal pathway may not be necessary for call production per se, the neuronal firing patterns that we found for the sensory-motor control of calls may play an important role for both song and call communication.

Layer-specific processing of ultrasonic calls in the auditory cortical fields of mice

Günter Ehret, Diana B. Geißler¹

¹University of Ulm, Institute of Neurobiology, Albert-Einstein-Allee 11, 89081 Ulm, Germany

In mother mice (*Mus musculus domesticus*) maternal motivation for pup-caring behavior is present right after delivery, evident e.g. when ultrasounds emitted by isolated pups release phonotaxis and retrieval of pups back to the nest. Virgin females need minutes or few hours of contact with pups to show pup-retrieval (Ehret & Koch, 1989). Selective phonotaxis, i.e. the discrimination of the acoustic quality of ultrasounds and preference of adequate models of pup calls, occurs in virgin females only after 5 days of experience with pups (Ehret & Buckenmaier, 1994). On that background of behavioral data, we study the role of the auditory cortical fields and particularly the activation of the auditory cortical layers in the emotional evaluation of adequate and inadequate models of pup ultrasounds (long or short tone bursts of 50 kHz) by mothers and virgins with 1 or 5 days of pup-experience.

Neural activation was shown via c-Fos immunocytochemistry in the auditory cortical fields: primary auditory field (AI), anterior auditory field (AAF), ultrasonic field (UF), second auditory field (AII), dorsoposterior field (DP). Fos-positive cells were counted in serial frontal sections (30 µm thick) of the auditory cortex (AC) of both hemispheres and were attributed to the cortical layers 2/3, 4, 5 and 6. To assign immunoreactive cells to the AC and its fields, the left AC was electrophysiologically mapped for tonotopy and field borders before the behavioral test of maternal behavior and c-Fos immunocytochemistry.

Here we show non-homogeneous distributions of Fos-positive cells across the cortical layers in the auditory cortical fields. I) In all fields of all experimental groups, Fos-positive cells occurred at very lower numbers in layer 4 compared to the other layers. II) In both hemispheres of the primary auditory cortical fields AI and AAF, one peak in the number of Fos-positive cells occurred over 2-4 sections independent of the call model. This peak had about 5-10 labeled cells above the background labeling (average 10-15 cells/section). The 50 kHz-induced amount of labeled cells in these peaks and in UF was similar in all experimental groups, which was mainly due to high numbers of Fos-positive cells in layers 2/3. III) In All of both hemispheres, recognition of the adequate call model led, mainly in cortical layers 2/3, to less labeled cells in mothers, while a tendency to more labeled cells than the background was seen in virgin females. IV) DP showed a left-hemisphere advantage in the number of Fos-positive cells in mothers and virgin females who recognized the adequate call model. This left-hemisphere advantage was due to an increased labeling in layers 2/3, 5 and 6. Increased maternal motivation in virgin females with 5 days compared to 1 day pup experience was expressed by increased labeling in field DP of 5 days caring virgins.

We conclude, that activation in primary fields (AI, AAF, UF) does not discriminate between the meaning of sounds and represents tone frequency by activation of layer 2/3. The biological meaning of ultrasonic calls is represented differently in All of mothers and virgin females and similarly by a left-hemisphere dominant activation in DP including, besides cortical layer 2/3 also layers 5 and 6. (Supported by the DFG, EH 53/20-1)

Ehret, G., and Buckenmaier, J. (1994) *J. Physiol. (Paris)* 88, 315-329.

Ehret, G., and Koch, M. (1989) *Ethology* 80, 81-93.

Multimodal signal intergration in the *Drosophila* CNS

Philipp Jaehde, Martin Goepfert¹

¹Johann-Friedrich-Blumenbach Insitute for Zoology and Anthropology, Department of Cellular Neurobiology, Julia-Lermontowa-Weg 3, 37077 Goettingen, Germany

The mating behavior of the fruit fly *Drosophila melanogaster* is controlled by sensory inputs of several different modalities. Female flies choose whether to accept or reject a potential mating partner based on volatile pheromones and the quality of his courtship song. Male flies sense a female's state of receptiveness via volatile and nonvolatile pheromones and her behavioral response to their courtship song.

Both sexes therefore have to integrate input from different sensory systems to decide whether to initiate courtship and eventually mate. These sensory systems have mainly been studied as isolated circuits, and it is not known where and how a combined processing of chemosensory, mechanosensory and visual input takes place in the *Drosophila* nervous system.

We are investigating the integration of the two most important sensory inputs for female flies in courtship, which are olfaction and hearing. To identify integration sites down to a single-cell level, we are using two-photon calcium imaging for detecting sound-evoked activity in neuropils already known to be involved in odor processing. We are further looking for bimodally activatable neurons in other candidate regions by using combined stimulation with both sound and odors.

Simultaneous but not sequential bilateral lesion of gerbil auditory cortex does extinguish pre-learned discrimination performance of fast amplitude modulated tones

Manfred Depner, Konstantin Tziridis¹, Holger Schulze¹

¹University Hospital Erlangen, Otorhinolaryngology - Head and Neck Surgery, Experimental Otolaryngology, Waldstr. 1, 91054 Erlangen, Germany

Fast periodic amplitude modulations (AM), which are perceived as “roughness” or virtual pitch, are an important characteristic of mammalian vocalizations like animal communication calls or human speech. In a previous study (Deutscher et al., Neuroreport 17, 2006) we demonstrated that bilateral ablation of auditory cortex (AC) eliminates the ability of gerbils to learn to discriminate between such AM differing in modulation frequency (fm). Here we demonstrate that this is not the case if AC hemispheres are ablated sequentially rather than at once.

Learning behavior and discrimination performance were studied using an aversive shuttle-box go/no go paradigm. Gerbils were trained for 15 days to discriminate between two AM tones with identical carrier frequency (2 kHz) and 160Hz or 320Hz fm, respectively. After successful learning animals received bilateral ablation of the AC, but with only one hemisphere at a time, either in left-right or right-left order. Each unilateral cortical ablation was followed by 15 days of additional training. Results were compared to sham lesioned control animals.

In contrast to simultaneous bilateral ablation of complete gerbil AC (cf. Deutscher et al., Neuroreport 17, 2006), sequential bilateral ablation as performed here did not lead to a severe impairment of pre-learned discrimination performance. By contrast, animals were still able to perform the task even after ablation of the second AC. This was independent of the order of the ablation. Animal subgroups that received cortical ablation of left or right hemisphere first both showed no significant effect on discrimination performance.

Our results indicate that one AC is sufficient for maintaining learned discrimination performance of fast AM. The consecutive ablation of the second AC in combination with our previous finding of impaired discrimination performance after simultaneous bilateral AC ablation points to a subcortical reorganization process that is triggered by the ablation of the first AC hemisphere to preserve the ability to discriminate fast AM even after lesion of the second AC.

Electrophysiological evidence for auditory motion-detectors in humans

Ramona Grzeschik, Martin Böckmann-Barthel¹, Roland Mühler¹, Jesko L. Verhey¹,
Michael B. Hoffmann²

¹Otto-von-Guericke University Magdeburg, Department of Experimental Audiology, Leipziger Strasse 44, 39120 Magdeburg, Germany

²Otto-von-Guericke University Magdeburg, Department of Ophthalmology, Visual Processing Laboratory, Leipziger Strasse 44, 39120 Magdeburg, Germany

Purpose: Adaptation with visual motion greatly affects visual evoked potentials to visual motion-onset [1]. Further, motion history can exert a strong effect on motion-onset auditory evoked potentials (AEPs), which is expressed by a recognizable positivation between 160 and 270 ms [2]. Here we tested whether the effect is direction specific, as this would indicate the contribution of veridical motion detectors to the response. **Methods:** Auditory evoked potentials (AEPs) were recorded from 33 EEG channels to motion onset of a sound (white noise) virtually moving in the horizontal plane at a speed of 60 deg/s from straight ahead (0 deg) to the left (-30 deg). AEPs for baseline- and adaptation-blocks were compared in a balanced design. In each trial (3500 ms duration) onset of a 500 ms epoch of auditory motion was presented after a 1000 ms epoch of a central stationary sound. For the baseline condition no motion history was presented (Baseline). The adaptation blocks were preceded by a 1 minute block of adaptation, consisting of an 1000 ms adaptor sound source moving 60 times from +30° to -30°, i.e. in the same direction as the test stimulus (Adaptation same direction) or, in a different block, in the opposite direction (Adaptation opposite direction). This preceding adaptation was topped up regularly after each stimulus trial by another two unidirectional repetitions of the adaptor sound. This paradigm allows the identification of direction-specific adaptation effects. Data from 12 subjects with super-threshold AEPs entered the analysis. **Results:** Typical motion-onset AEPs were obtained for the Baseline, namely a fronto-central response complex dominated by a negative and a positive component, the so-called change-N1 (cN1) and change-P2 (cP2) after around 160 and 250 ms, respectively. cN1-amplitudes for Adaptation same direction were significantly smaller than for Baseline and remarkably also for Adaptation opposite direction (see Figure). Significant adaptation effects were absent for cP2 amplitudes and for cN1 and cP2 latencies. These findings demonstrate cN1 adaptation that is specific for stimulus direction. **Conclusion:** The observed direction-specific effect of motion history indicates the contribution of auditory motion detectors to the cN1 of the motion-onset AEP, i.e. at around 160 ms after stimulus onset.

[1] Hoffmann MB, Unsoeld AS, Bach M (2001) Directional tuning of human motion adaptation as reflected by the motion VEP. *Vision Research* 41:2187-2194

[2] Grzeschik R, Bockmann-Barthel M, Muhler R, Hoffmann MB (2010) Motion-onset auditory-evoked potentials critically depend on history. *Exp Brain Res* 203: 159-168

Supported by the Deutsche Forschungsgemeinschaft (DFG HO-2002/6-1) and a scholarship to RG (Medical Faculty, Otto-von-Guericke University, Magdeburg).

Figure legend: Grand mean traces of Baseline, Adaptation same direction, and Adaptation opposite direction conditions (n=12) for the site FC_G. Motion onset and offset of the test phase are indicated by vertical lines. Voltage vs. time (central traces) and logarithmised p-value vs. time are plotted (top and bottom traces) for the different conditions as indicated. P-Values are logarithmically scaled from 10⁰ to 10⁻⁷ (left hand scale), p=0.001 is indicated by a horizontal line. Significant deflections are indicated by '+'.

The asterisks ‘**’ and ‘*’ indicate significance levels of $p < 0.003$ and $p < 0.02$ for cN1 amplitudes determined with an individual single peak analysis.

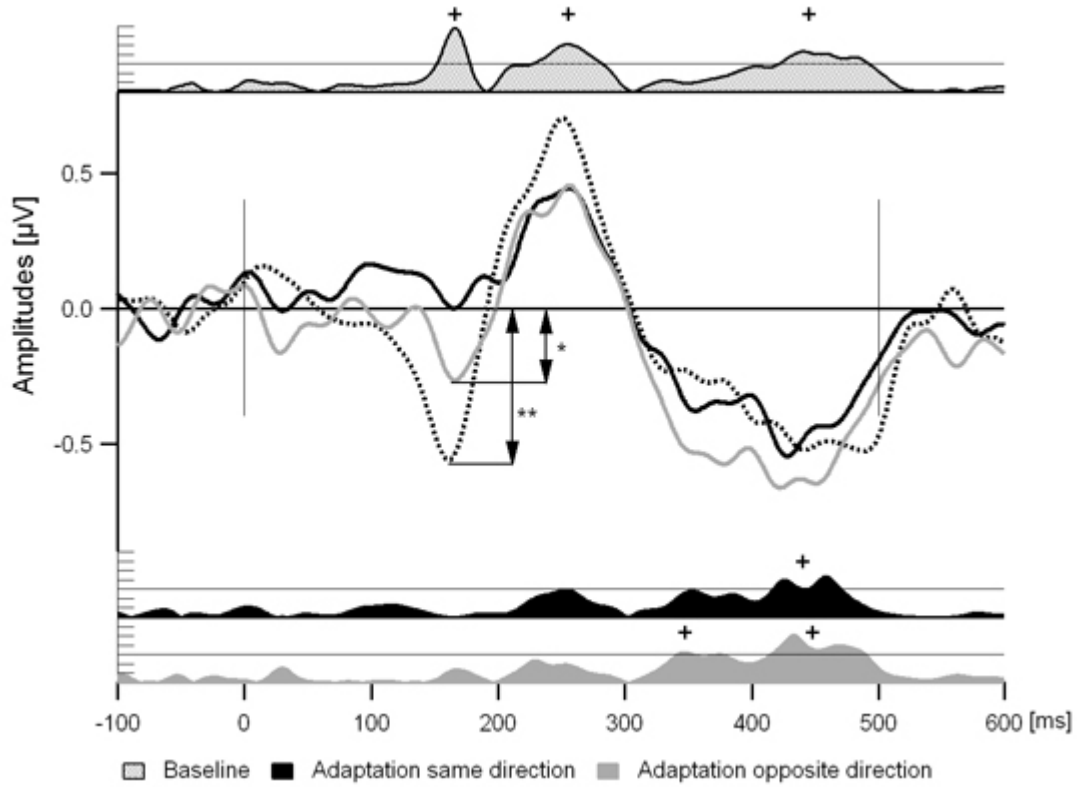

Activity dependent regulation adjusts the duration of inhibition in an echo suppression circuit

Julian Ammer, Felix Felmy¹

¹Ludwig-Maximilians University Munich, Division of Neurobiology, Department Biology II, Großhaderner Str. 2, 82152 Martinsried, Germany

²Graduate School of Systemic Neurosciences, Ludwig-Maximilians University Munich, Germany

Sound localisation in reverberant environments is impeded by the presence of echoes. To filter out the relevant localisation cues, the auditory system has to suppress the directional information of echoes. An elementary step in this process seems to be implemented in the circuitry of the dorsal nucleus of the lateral lemniscus (DNLL). The DNLL generates a GABAergic inhibition that lasts long enough to inhibit responses to trailing sounds for tens of milliseconds in the contralateral DNLL mimicking psychophysical findings. In contrast, single GABAergic IPSC in the DNLL in vitro decay with a time constant of ~ 4 ms, seeming too fast to explain the long lasting inhibition in vivo. However, in vitro data from juvenile gerbils suggest that the inhibitory time course could be prolonged depending on the presynaptic activity. In this study we investigate the activity dependence of the GABAergic inhibition in the DNLL and the factors which are important to effectively suppress action potentials.

We performed in vitro patch clamp experiments in acute brain slices from P30-35 Mongolian Gerbils at near physiological temperatures.

First, we analysed the synaptic properties of the GABAergic inhibition by stimulating pharmacologically isolated synaptic currents via the commissure of Probst. The GABAergic IPSC decay time constant increased with increasing stimulation frequency, strength and pulses number, indicating an activity dependent process. Pharmacological dissection of the underlying synaptic mechanisms showed that transmitter spill over and asynchronous release contribute to the prolongation of the GABAergic decay time constant. Next, we investigated how IPSCs are integrated and converted into IPSPs. The GABAergic IPSPs are strongly hyperpolarising, as the chloride reversal potential is around -90 mV. The membrane properties between the resting potential and the reversal potential indicate that synaptic GABA conductances are integrated passively. A passive model and a steady state approximation based on these data confirm the experimental results that larger synaptic conductances cause slower IPSPs. The injection of synaptic conductances shows that DNLL neurons transform the activity dependent slowing of IPSCs into a long lasting hyperpolarisation. Finally, this hyperpolarisation is indeed sufficient to suppress action potentials for tens of milliseconds, an effect not generated by shunting inhibition.

Taken together, our data indicate that activity-dependent, hyperpolarising inhibition can mimic the long lasting inhibition in vivo underlying the suppression of directional information of echoes during sound localisation.

Calcium entry sites of neurons in the medial superior olive

Felix Felmy, Sarah Berner ^{1,2}, Delwen Franzen ^{1,2}, Susanne Blank ¹, Christian Kellner ^{1,2}

¹Ludwig-Maximilians University, Biocenter, Department Biology II, Division of Neurobiology,

²Graduate School of Systemic Neurosciences, Ludwig-Maximilians University Munich, Germany

³Biolmaging Center, Department Biology I, Ludwig-Maximilians University Munich, Germany

Calcium, a major second messenger, exhibits many functions in neurons, including the modulation of the action potential (AP) waveform and synaptic plasticity. The calcium entry site, the location of calcium transients and the cellular calcium buffering all play an important role in its action. As sensory neurons change during postnatal development, their calcium influx and homeostasis might also change to promote different functions of this second messenger. In binaural coincidence detector neurons of the medial superior olive (MSO) the membrane properties and their inputs become refined during late postnatal development. Here, we investigate the calcium entry sites and their developmental regulation in MSO neurons.

The calcium entry sites and calcium currents were investigated using whole-cell patch-clamp recordings in voltage- and current-clamp mode. EPSCs were stimulated with a monopolar glass electrode placed in the vicinity of a MSO dendrite. Calcium transients were imaged using OGB-1 (30 μ M). All experiments were conducted in acute brain slices from gerbils either shortly after hearing onset of postnatal day (P) 13-15 or in matured stages (P60) at near physiological temperature.

At P13/14, single and triple APs evoked calcium transients throughout the dendrite. However, no AP-induced calcium transients were observed at P60, possibly as a consequence of strongly reduced AP amplitude and a change in calcium channel subsets. The whole-cell calcium current does indeed exhibit developmental alterations. At P13/14, T-type calcium currents are present that dissipate within one day, as they are absent from P15 onwards. Furthermore, the amplitude of the whole-cell calcium current decreases between P15 and P60. Together this indicates that changes in AP waveform and voltage-gated calcium channels lead to a loss of AP-induced calcium current during maturation. EPSCs serve as a different source of calcium entry into neurons. At P13, single EPSCs and trains of EPSCs lead to a significant calcium influx localized at distinct dendritic sites. If an NMDA response is present at the stimulated fibre, the evoked calcium transient is mediated by both AMPA and NMDA receptors. In adult animals AMPA-mediated calcium entry is still present. However, the EPSC-evoked calcium transients appear smaller in P60 animals. This apparent developmental reduction in the EPSC-evoked calcium influx is consistent with a developmental upregulation of the GluR2 subunit.

Overall, our data suggests that the calcium influx into MSO neurons becomes reduced during late postnatal development. Also a developmental shift from a global AP-evoked calcium influx to a more local EPSC-mediated influx appears to take place. Thereby, the calcium entry shifts from its pre- and postsynaptic activity dependence to a predominantly presynaptic activity dependence.

Variability of Sound Source Position and Temporal Feature Representation in Across-Frequency Integrating Neurons of the Barn Owl.

Philipp Tellers, Kerstin Bülles¹, Hermann Wagner¹

¹RWTH, Aachen, Institute for Biology II, Mies-van-der-Rohe Straße 15, 52074 Aachen, Germany

The acoustic system needs to code where a sound source is located and what kind of source it is. Keller and Takahashi (J Neurophysiol 84:2638 (2000)) showed that neurons of the central nucleus of the inferior colliculus (ICC) are able to code both, the “where” and the “what”. The location of a sound source was represented by the maximum firing rate in response to interaural time (ITD) and level (ILD) differences, while temporal feature of the sound were represented by the discharge pattern of the neurons.

The acoustic pathway branches at the level of the ICC to create a forebrain and a midbrain pathway. Both pathways receive input from the ICC, both integrate information of different frequency channels, and the neurons of both pathways are significantly tuned to ITD. ICC neurons exhibit a high firing rate with low variability in response to ITD stimuli (Christianson and Pena, J Neurosci 26:5948 (2006)).

We recorded extracellularly from single neurons of the external nucleus of the inferior colliculus (ICX, midbrain) and the auditory arcopallium (AAr, forebrain). We used “de novo” generated noise and different “frozen” noise samples to examine to what degree and how precise the sound source position and the temporal features of acoustic sounds are represented in these nuclei.

While firing rate decreased from ICC to ICX, variability increased. Preliminary data of AAr neurons showed the same effect. We could not observe any difference between the firing rate and the variability in response to “de novo” and “frozen” stimuli neither at the population nor at the neuron level.

Across-frequency integration leads to increased variability and is accompanied by a decrease in firing rate. The missing difference between “de novo” and “frozen” noise indicated a stimulus independent rate code for ITD representation in these neurons.

NMDA-dependent enhancement of rate coding in the auditory brainstem.

Ida Siveke, Julian Ammer¹, Benedikt Grothe¹, Felix Felmy¹

¹Ludwig-Maximilians-Universität München, Division of Neurobiology, Grosshaderner Str. 2, 82152 Muenchen, Germany

Low frequency neurons in the dorsal nucleus of the lateral Lemniscus (DNLL) are sensitive to interaural time differences. They directly inherit this sensitivity from neurons of the superior olivary complex. Coincidence detector neurons in the superior olivary complex translate the binaural temporal code into a rate code. At the second stage of this binaural pathway DNLL neurons improve the rate code generated at the site of coincidence detection. This improvement is due to a reduction in the variability of neuronal responses in the DNLL compared to the superior olivary complex. However the cellular mechanisms of this enhancement are unclear. Interestingly, recent *in vitro* data from our lab showed that the synaptic NMDA currents amplify the postsynaptic activity in adult DNLL neurons.

In this study we now linked *in vivo* measured improvement to the *in vitro* measured NMDA dependent amplification of spike generation investigating the role of NMDA currents on the neuronal activity of DNLL neurons in adult Mongolian gerbils. While pharmacologically blocking the NMDA current we measured the contribution of NMDA receptor mediated activation on the binaural responses in terms of rate, time, and variability *in vivo*.

In vivo the neuronal activity in adult gerbils is significantly reduced after blocking the NMDA current. Besides the onset of the response to pure tones is strongly reduced by applying NMDA antagonists. This reduction of the ongoing component resulted also in shorter responses to tone stimulation. Furthermore the fano factor, a measure of response variability, significantly increases after blocking the NMDA current, which implies a higher variability in the neuronal response after blocking. The NMDA receptor induced enhancing of the rate code directly enhanced the neuronal coding of interaural time differences. This NMDA dependency is in line with *in vitro* findings that show a reduction in the number of spikes in response to fibre stimulation in a frequency dependent manner.

Taken together a NMDA sensitive component amplifies neuronal activity in the DNLL. This supports the transition from a predominantly temporal to rate-code information at this second stage of the binaural pathway.

Investigating adaptation in the barn owl with a double-stimulus paradigm: a behavioral approach

Lutz Kettler, Sandra Brill¹, Dana Zähringer¹, Hermann Wagner¹

¹RWTH Aachen, Department of Zoology and Animal Physiology, Mies-van-der-Rohe-Straße 15, 52074 Aachen, Germany

During hunting barn owls attend to sounds - as for example rustling generated by prey. The birds typically do not attack upon hearing the first sound, but wait for a second sound. This situation was mimicked with a double-stimulus paradigm. It was tested behaviorally whether and how a first or reference sound influenced the head turning of the birds towards a second sound or probe. The inter-stimulus interval between reference and probe was varied between 100 ms and 3200 ms on a log₂ scale. Additionally, the owls were stimulated with single stimuli. Preliminary data collected with three adult barn owls indicate a reduction in precision of head-turning responses when two successive stimuli were presented compared with a situation where only a single sound was presented. Furthermore, head-turning latencies were increased in the double-stimulus condition. This indicated response adaptation. Latencies as well as head-turning precision returned to the level of the single-sound condition if the duration of the inter-stimulus interval was increased. The time constant of recovery from adaptation coarsely matched time constants that were determined in electrophysiological experiments. Thus, a first stimulus rather lowers than facilitates the response to a second stimulus under the conditions examined.

Levels of GAP-43 mRNA Reflect Modified Stimulation-Dependent Activity in the Auditory Brainstem of Rats

Nicole Rosskothén-Kuhl, Ralf Birkenhäger², Robert-Benjamin Illing¹, Robert-Benjamin Illing¹

¹Neurobiological Research Laboratory, Department of Otorhinolaryngology, University of Freiburg, Killianst. 5, 79106 Freiburg, Germany

²Molecularebiological Research Laboratory, Department of Otorhinolaryngology, University of Freiburg, Killianst. 5, 79106 Freiburg, Germany

In early life, millions of synapses develop in the mammalian brain. Over this time, high levels of phosphoprotein GAP-43 were detected in neuronal somata, axons, and immature synapses. With maturation of the nervous system, synthesis of this protein decreased in most neurons, including those of the central auditory system. However, some regions maintain basal levels of GAP-43 protein and mRNA, among them the lateral superior olive (LSO) and the central inferior colliculus (CIC). An additional region maintaining GAP-43 is the hippocampus, known for its involvement in learning.

It is still unknown what happens molecularly in the adult brain if one ear or both fail? Can a cochlear implant help to replace the missing input on the molecular level? This study investigated the correlation between the GAP-43 mRNA expression and the symmetry of bilateral sensory inputs within the auditory system of rats.

GAP-43 protein and mRNA levels were quantitatively determined in the LSO and the central CIC. To create auditory input variations, we worked with four experimental groups of young adult, wild-type Wistar rats. (1) Normal hearing control rats, rats with bilateral (2) or unilateral (3) passive cochlear implant(s) CI(s) for up to 10 weeks, and (4) rats with a unilateral active CI, stimulated for up to 7 days.

We demonstrated that GAP-43 mRNA levels shifted as a function of input balance and activity pattern. In group (1) and (2), GAP-43 mRNA levels were bilaterally symmetrical in LSO and CIC. By contrast, mRNA levels were significantly unbalanced for group (3). Neurons in contralateral LSO expressed GAP-43 mRNA above control level. Ipsilateral CIC reached significance against control after long-term implantation of 3 or 10 weeks. With monaural stimulation (4), GAP-43 mRNA levels were found to be left-right symmetrical on both sides of LSO and CIC. Still, expression levels rose beyond control levels in LSO for all stimulation times and in CIC by 7 days of EIS.

These data suggest that GAP-43 is a marker beyond monitoring neurite outgrowth and early stages of synaptogenesis. When the bilaterally symmetrical auditory system fails to generate symmetrical neuronal activation, this imbalance is displayed by levels of GAP-43 mRNA expression. Remarkably, this balance can be completely sustained if a dysfunctional ear receives simple patterned stimulation by a CI.

A Staining for GAP-43 mRNA throughout LSO

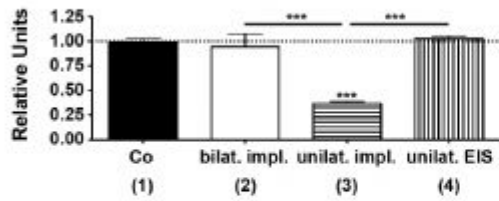

B Staining for GAP-43 mRNA throughout CIC

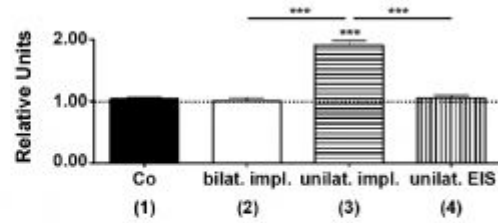

Simplified results of GAP-43 mRNA quantification.

Rate evaluation of GAP-43 mRNA in LSO (A) and CIC (B) indicate that GAP-43 mRNA levels were unbalanced between left and right side of the brainstem if auditory activity was lower on one side as compared to the other. By inserting and directly activating a cochlear implant on the deafened side, mRNA levels maintained left-right balance. Significant differences against control are displayed by asterisks: (***) = $p < 0.001$. Co: control group; unilat.: unilateral; bilat.: bilateral; impl.: implantation; EIS: electrical intracochlear stimulation.

Inhibitory synapses in the developing auditory brainstem transiently release zinc which elicits postsynaptic calcium responses

Elisabet Garcia-Pino, Maria E. Rubio¹, Catherine J. Weisz¹, Kandler Karl¹

¹University of Pittsburgh, Department of Otolaryngology, Auditory group, Biomedical Science Tower 3, Rm. 10027 3501 5th Ave, 15261 Pittsburgh, PA, USA

Approximately 10% of total zinc in the mammalian brain is loosely bound within synaptic vesicles from where it is co-released along with excitatory and inhibitory neurotransmitters. Synaptically released zinc can interact with numerous postsynaptic targets including NMDA, GABAA, Glycine, and G-protein coupled receptors thus making it an important modulator of neurotransmission and plasticity. However, the role of zinc in developmental plasticity, especially of inhibitory circuits, is poorly understood. In the auditory brainstem, the glycinergic pathway from the medial nucleus of trapezoid body (MNTB) to the lateral superior olive (LSO) undergoes pronounced functional and anatomical refinement during the first postnatal weeks. Here, we use anatomical and imaging methods to investigate whether and at what developing stages synaptic zinc participates in neurotransmission at MNTB-LSO synapses in neonatal mice.

Histological zinc staining demonstrated the transient presence of punctate zinc labeling in the LSO. Labeling was undetectable in newborn mice (P2), clearly visible in one week old mice (P7), and undetectable in older mice (P12 and P30). Electron microscopy indicated zinc-labeling in synaptic terminals forming symmetrical synaptic contacts, consistent with the presence of synaptically releasable zinc in MNTB-LSO synapses. Stimulation of MNTB fibers elicited a zinc-mediated, transient increase in the postsynaptic Ca²⁺ concentration in LSO neurons in one week old mice. No zinc mediated Ca²⁺ responses were observed in newborn mice (P2-P3) or in ZnT3 KO mice which lack vesicular zinc transporter 3. In addition, stimulation of glutamatergic synapses formed by cochlear nucleus neurons elicited no zinc-mediated responses. Together, our results indicate that during the period of synaptic refinement developing MNTB-LSO synapses release zinc as a co-transmitter to activate postsynaptic Ca²⁺ signaling. We hypothesize that the transient zinc signaling contributes to the elimination and/or strengthening process of MNTB-LSO synapses.

Supported by NIDCD (004199)

Auditory Input to Tegmental Neurons and its Modulation by Striatal Activity

Anna C. Schneider, Wolfgang Walkowiak¹

¹University of Cologne, Biocenter, Zùlpicher Straße 47b, 50674 Köln, Germany

The anuran Tegmentum receives multimodal sensory input. Amongst others, it is reciprocally connected to the Striatum and the Torus semicircularis (Ts), which is an important structure in the auditory pathway and known to act as an audio-motor interface¹. The Striatum is part of the basal ganglia, and a presumed homologue of the mammalian Substantia nigra pars reticulata (SNr) has been delineated in the anuran Tegmentum by immunohistochemical methods². Stimulation of the Striatum prior to auditory stimulation modulates the responses of Ts neurons³. In addition to Ts neurons, it has been shown that both tegmental and striatal neurons react to auditory stimulation^{1,4}. Auditory tegmental neurons also show caudal projections to vocal premotor areas. These areas include two pattern generators required for advertisement call generation⁵.

The aim of this study was to investigate a possible modulatory role of striatal activity on tegmental auditory processing and to determine tegmental projections into vocal motor areas. We retrogradely traced neurons projecting to the area of the caudally situated vocal pattern generator by backfills with neurobiotin or tetramethylrhodamine in isolated brains⁶ of *Bombina orientalis*. Among the labelled structures were the Nucleus laminaris of the Ts, emphasising the role of the Ts as audio-motor interface, and the Tegmentum, indicating connections with vocal premotor areas. Intracellular recordings of tegmental neurons responding to electrical stimulation of the auditory nerve confirmed auditory input to tegmental neurons. Preceding electrical striatal stimulation resulted either in an increase or decrease in latency, number of action potentials, or duration of inhibition; one third of the recorded neurons were unaffected. Notably, 17 % of the recorded neurons were tonically active and preceding striatal stimulation resulted in increased inhibition in all of them. We used intracellular neurobiotin injections to detect the location of the recorded neurons and to reconstruct them via camera lucida drawings. Somata were mainly located in the Tegmentum, but also in the Formatio reticularis and the Nucleus medullaris dorsalis, which is the termination site for auditory nerve fibres. Tegmental neurons showed either local or extensive caudal projections, the latter terminating in vocal premotor areas.

Electrophysiological data confirmed our hypothesis that responses of tegmental auditory neurons can be modulated by the Striatum, resulting in facilitation (43% of the recorded neurons) or inhibition (17% of the recorded neurons). The anatomical results suggest that these neurons contact premotor areas in the brainstem. Therefore, it is possible that the Tegmentum contains an additional audio-motor interface. The responses of the tonically active neurons to preceding Striatum stimulation together with the established histochemical data further point to the existence of a SNr homologue in the anuran Tegmentum.

¹ Walkowiak & Luksch 1994

² Maier, Walkowiak, Luksch & Endepols 2010

³ Endepols & Walkowiak 2001

⁴ Luksch 1998; Roden 2002

⁵ Schmidt 1992

⁶ Luksch, Walkowiak, Muñoz & ten Donkelaar 1996

GABA_B receptor mediated adaptation in medial superior olive neurons

Annette Stange, Andrea Lingner¹, Michael H Myoga¹, Felix Felmy¹, Ida Siveke¹,
Michael Pecka¹, Benedikt Grothe¹

¹Ludwig-Maximilians-Universität München, Department of Biology II, Division of Neurobiology, Planegg-Martinsried, Germany

It is well established that human listeners adapt in their judgement of the lateral position of low-frequency sound sources depending on the nature, timing and location of preceding sound stimulation. Recently it has been shown that interaural level difference processing in the lateral superior olive (LSO), which is important for localizing high-frequency sounds, is subject to binaural adaptations mediated by GABA_B receptors (Magnusson et al. 2008). The location of low-frequency sounds is first encoded in the medial superior olive (MSO) that precisely detects interaural differences in the arrival time of a sound at the two ears (ITDs). GABA_B receptors are expressed in the MSO, but in contrast to LSO neurons it is unclear whether MSO neurons also adapt their binaural sensitivity.

Here, we performed human psychophysical experiments and *in vivo* extracellular recordings of single MSO neurons in adult Mongolian gerbils to investigate adaptation in ITD-based sound localization using the same stimulus paradigm in both approaches. Moreover, we applied pharmacological manipulations *in vivo* and *in vitro* to determine the synaptic mechanism underlying neuronal adaptation.

Our human psychophysical and *in vivo* electrophysiological studies show that adapter tone pips change human perception of the location of test tones and spike rates of gerbil MSO neurons, respectively. Specifically, we find that the spike rates during the test tones were negatively correlated with the spiking activity of individual MSO neurons to the adapter, suggesting an activity-dependent adaptation. Importantly, a similar reduction in spiking activity as found during the tone-evoked adaptation could be elicited by iontophoretically applying GABA without presenting adapter sounds. Moreover, the overall spike rate decreased strongly during application of the GABA_B receptor agonist baclofen, and conversely, antagonizing GABA_B receptors with CGP 55845 increased spiking activity. In line with this, *in vitro* patch-clamp studies revealed that GABA_B receptors modulate both excitatory and inhibitory inputs to the MSO in a dose-dependent manner.

Taken together, our results suggest that MSO neurons adapt their spike rate according to their preceding spiking activity through a GABA_B receptor mediated feedback loop. This feedback loop might serve as a dynamic adjustment during changing environments.

Interaural coherence as a basis for a robust and efficient sound localization model.

Tom Goeckel, Hermann Wagner¹, Gerhard Lakemeyer²

¹RWTH Aachen University, Department for Biology II, Mies-van-der-Rohe Strasse 15, 52056 Aachen, Germany

²RWTH Aachen University, Knowledge-based Systems Group, Ahornstrasse 15, 52056 Aachen, Germany

Binaural sound source localization in home environments is encumbered in the presence of strong reverberations. Our goal was to develop an efficient real-time algorithm that improves the localization performance in echoic environments and is able to track sound sources through time and space. As localization cues we used a combination of interaural time differences (ITD) and level differences (ILD), which were analyzed for their reliability using interaural coherence (IC), or the normalized cross-correlation coefficients. A pair of ITD and ILD values is determined for each sample of the digital input signal in each frequency band, and subsumed in a probability density function (PDF) weighted with the corresponding IC values. To merge ITD cues across frequencies we used a summed average in combination with the frequency-specific reliability index. Peaks in the ILD PDFs are matched with our reference ILD values, and the related sound source directions are compared to the peaks in the ITD PDFs to find the most likely sound source locations. The results are integrated over time to emphasize consistent sound sources and to take gaps in the signal into account. To evaluate the performance of our algorithm tests with noise and speech signals in different echoic conditions, and with several degrees of background noise, have been performed. We could show a significant increase of localization accuracy in reverberant environments in comparison to algorithms purely relying on ITD and ILD values. We combined several simple methods to extract sound source directions with the least possible computational costs, and show that this algorithm is still able to extract usable localization information in reverberant, and other adverse acoustical conditions.

Role of auditory interhemispheric connections in lateralized sound processing by Mongolian gerbils

Katja Saldeitis, Marcus Jeschke², Max F. K. Happel², Wolfram Wetzel³, Henning Scheich¹, Frank W. Ohl², Eike Budinger¹

¹Leibniz Institute for Neurobiology, Department Auditory Learning and Speech, Brenneckestraße 6, 39118 Magdeburg, Germany

²Leibniz Institute for Neurobiology Magdeburg, Department Systems Physiology of Learning, Brenneckestr. 6, D-39118 Magdeburg, Germany

³Leibniz Institute for Neurobiology Magdeburg, Special Lab Behavioral Pharmacology, Brenneckestr. 6, D-39118 Magdeburg, Germany

There are numerous indications of hemispheric specializations in the auditory cortex with respect to the processing of certain temporal and spectral aspects of auditory stimuli. This is most evident in humans (e.g., left hemispheric dominance of speech and right hemispheric dominance of music processing) but also in Mongolian gerbils (*Meriones unguiculatus*). In this frequently used animal model of auditory research, we could show previously by means of large uni- and bilateral auditory cortex lesions that the left auditory cortex is essentially involved in the processing of segmented (discrete) frequency modulated tone (FM) sequences and the right auditory cortex in the processing of continuous FM sweeps (Wetzel et al., PNAS, 2008).

We now ask for the anatomical network underlying the lateralized processing of FMs in the auditory cortex. In a first set of experiments, we investigated the role of interhemispheric connections in the ability of Mongolian gerbils to discriminate continuous FMs.

To address this issue we eliminated the auditory cortical commissural neurons by using a targeted laser-induced apoptosis method. Therefore, we injected a photolytic tracer (chlorine e6-conjugated retrobeads) into the left or right auditory cortex of the animals. After the retrograde axonal transport of the tracer the contralateral auditory cortex was illuminated with long-wave laser light. This illumination resulted in an intracellular chemical release of free radicals and in a consequent apoptosis of the labelled interhemispheric projection neurons. Then, the lesioned as well as sham-operated control animals were tested in a behavioural Go/No-Go target-discrimination paradigm using continuous rising vs. falling FMs (shuttle box, ten sessions á 60 trials, one session per day; FM tones 1-2 kHz, 70 dB SPL).

Our behavioural data show that the lesioned animals learned the discrimination task considerably slower than the control animals. Whereas in control animals the discrimination rate increased steeply at day three (reaching its plateau by day five) the performance levels of animals with photolytic lesions increased more slowly and constantly and achieved their highest values not until day eight. Thus, significant differences between the control groups and the lesioned animals were observed from sessions three to five, whereas from session eight on, performance levels were almost equal.

To conclude, the results indicate that the interhemispheric connections between the left and right auditory cortices play an essential role during the initial learning phase of a FM detection task. Further sets of experiments (e.g., with segmented FMs, corticofugally lesioned animals) are planned to further disentangle the functional roles of interhemispheric and other connections to lateralized auditory cortical processes in gerbils and to finally provide implications for the processing of speech and music in humans.

The claustrum in the Mongolian gerbil (*Meriones unguiculatus*): Architecture and connections with primary sensory and frontal association cortices

Julia Henschke, Eike Budinger¹, Henning Scheich¹, Susanne Radtke-Schuller²

¹Leibniz Institute for Neurobiology, Auditory Learning and Speech, Brenneckestraße 6, 39118 Magdeburg, Germany

²Division of Neurobiology, Department Biology II, Ludwig-Maximilians-Universität München, Großhaderner Straße 2, D-82152 Planegg-Martinsried, Germany.

The claustrum (Cl) is a rather ill-defined mammalian forebrain structure whose precise architecture and function still remain elusive. Based on its reciprocal connections with virtually all cortical areas, the Cl has been suggested to integrate multisensory information and/or to coordinate widespread cortical regions for specific behavioral and cognitive tasks.

In rodents, the thin sheet-like grey matter of the Cl is sandwiched between the fibers of the capsula externa and the deep layers of the insular, lateral orbital and piriform cortex. Attempts to define the Cl on cytoarchitectural grounds alone have been discussed controversially and led to varying descriptions of claustral boundaries.

Here, we report on the detailed cyto-, fiber- and chemoarchitecture of the Cl and the adjacent endopiriform nucleus (En; named 'ventral Cl' by some authors) in Mongolian gerbils and on their direct connections with the primary auditory (A1), visual (V1) somatosensory (S1), and frontal association cortex (Fr2).

In order to delineate the anatomical boundaries of the Cl and En we used cell- (Nissl), myelo- (Gallyas), chemo- (acetylcholinesterase, cytochrome oxidase, NADPH-diaphorase) and immunohistochemical (calcium-binding proteins calbindin and parvalbumin) techniques. The obtained data as well as the subsequent connectional data were related to a reference series of frontal sections consecutively stained for cells and myelin and were compared to those in atlases of other rodents and mammalian species.

The connectivity pattern between Cl and A1, V1, S1 and Fr2 was examined by means of the bidirectional sensitive fluorescent tracers fluorescein-labeled dextranamine (FDA) and tetramethylrhodamine-labeled dextranamine (TMRDA). Generally, injections yielded largely overlapping anterograde and retrograde labeling in the Cl indicating rather reciprocal connections between these three primary sensory and the frontal cortices and the Cl.

Following double injections of FDA and TMRDA into A1/V1, V1/S1, A1/S1, A1/Fr2, S1/Fr2 and V1/Fr2, respectively, modality-related labeling was distributed topographically in partially overlapping clusters. In the gerbil Cl, there is a slight rostro-caudal gradient in these connections, with cells projecting to Fr2 located most rostral, followed by the cells projecting to S1, V1 and A1, respectively. A substantial caudal part of En showed no connections with the neocortical areas studied here and thus might be a projection target of and source of projections to the amygdala like in the rat. No double-labeled neurons were detected. This suggests a separate functional representation of sensory modalities in the Cl; however, there are also zones of possible multisensory integration indicated by overlapping labeling.

Determination of pure-tone hearing thresholds in Eurasian otters (*Lutra lutra*) using brainstem auditory evoked potentials (BAEP)

Mathias Benjamin Voigt, Christian Hackenbroich², Hans-Heinrich Krüger³, Arne Liebau^{1,4}, Karl-Heinz Esser^{1,4}

¹ Auditory Neuroethology and Neurobiology, Institute of Zoology, University of Veterinary Medicine Hannover, Hannover, Germany

² Tierklinik Northeim GbR, Eschenschlag 10, 37154 Northeim, Germany

³ Otter-Zentrum, Sudendorfallée 1, 29386 Hankensbüttel, Germany

⁴ Center for Systems Neuroscience Hannover, Hannover, Germany

The Eurasian otter (*Lutra lutra*, L. 1758) is one of the flagship species of ongoing natural conservation efforts in Europe. Currently, the German populations are regaining in strength and recolonising wide areas of their original distribution range due to extensive work in the field of habitat improvement. Nevertheless otters are listed as near threatened by the IUCN and their overall population trend is considered to be declining. As a top predator species, otters are lacking serious predation pressure and the main threats they are facing are man-made. Besides casualties due to traffic encounters one of the major causes of mortality is the drowning in fyke nets (Reuther 2002). These freshwater fish traps, set mainly for eels, have a great attracting value to otters through their concentration of food resources in a small space. But inherent to their functional principle of not letting animals escape once caught, they pose a high risk of drowning. One possible mitigation mechanism to prevent mammals to be caught in marine fishing gear is the use of acoustic deterrent devices called pingers. Because of the known effectiveness of marine pingers it was proposed to construct otter-specific pingers for future use on fyke nets. A prerequisite for the construction of these devices is knowledge about the specific hearing capabilities of the animals they are constructed for. Therefore, we determined pure-tone hearing thresholds in Eurasian otters using brainstem auditory evoked potentials (BAEP). In cooperation with the German Association for Otter Conservation (Aktion Fischotterschutz e.V.) we examined 5 adult female otters using a previously established auditory-evoked-potential protocol. During isoflurane anaesthesia, we visually determined the presence of an electric brainstem response to tone pulses (50 ms) in the frequency range between 128 Hz and 32.7 kHz systematically varied in amplitude (dB SPL, sound pressure level). The result was a V-shaped audiogram with a region of best hearing around 4 kHz (see Figure). The relatively high minimum hearing thresholds found in the Eurasian otter can presumably be explained by insensitivities inherent to the BAEP-method. On the other hand, relatively high SPL thresholds could be explained by an ecological lack of the need for a high developed hearing system in this species of underwater foragers.

References:

Reuther, C. (2002): Otters and Fyke Nets – Some Aspects which Need Further Attention. IUCN Otter Spec. Group Bull. 19(1):7-20

Figure caption:

Brainstem auditory evoked potential (BAEP) audiogram of *Lutra lutra*. Bold line: mean values of up to 5 animals; light lines: range of individual thresholds.

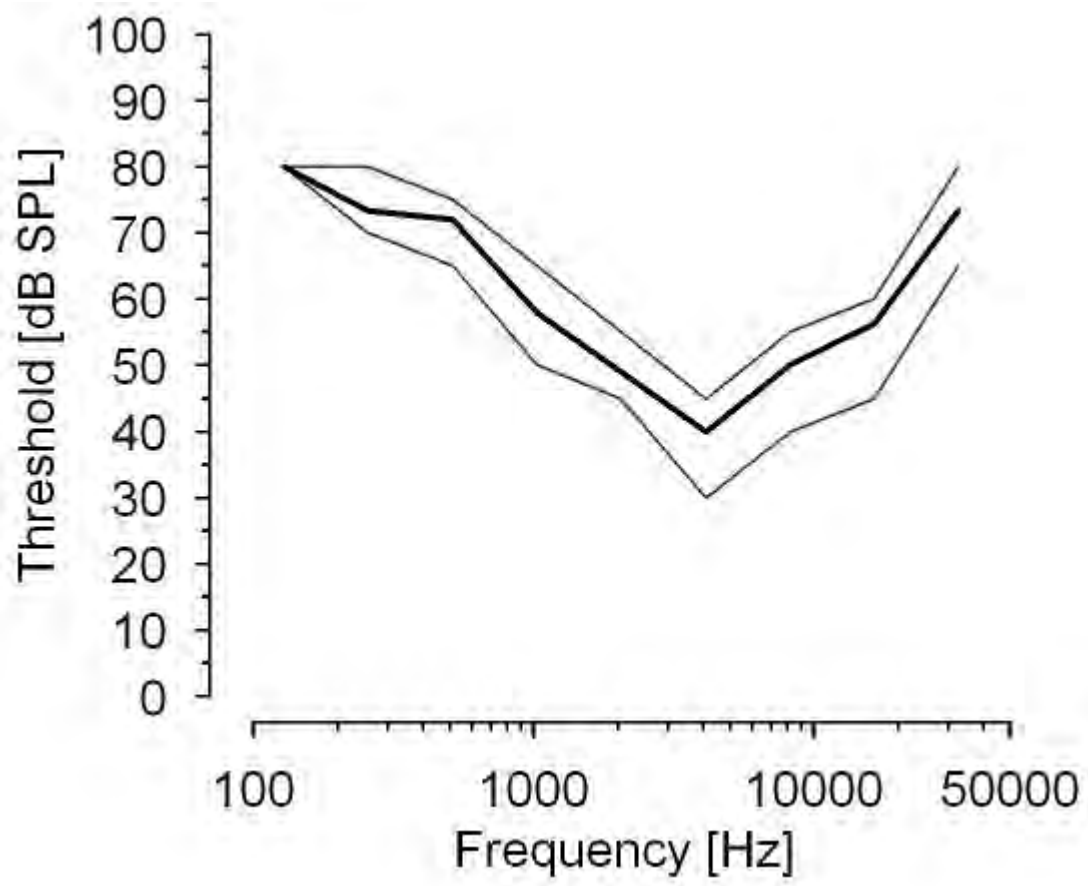

Hearing during aging in the emerging primate brain aging model *Microcebus murinus*: a BERA study

Christian Schopf, Elke Zimmermann¹, Julia Tünsmeier², Sabine B.R. Kästner², Andrej Kral³

¹University of Veterinary Medicine Hannover, Foundation, Institute of Zoology, Bünteweg 17, 30559 Hannover, Germany

²University of Veterinary Medicine Hannover, Foundation, Department of Small Animal Medicine and Surgery, Bünteweg 9, 30559 Hannover, Germany

³Medical University Hannover, Institute of Audioneurotechnology & Department of Experimental Otolology, ENT Clinics, Feodor-Lynen-Straße 35, 30625 Hannover, Germany

Mouse lemurs are the smallest primates in the world. They communicate with an elaborate set of vocalizations in the high-frequency and ultrasonic range and are discussed as an emerging new primate model for brain aging research. The aim of this study was to gain first empirical information on auditory thresholds and hearing sensitivity in grey mouse lemurs (*Microcebus murinus*) during aging.

We applied brainstem evoked response audiometry (BERA), a cost-efficient method traditionally used for screening hearing sensitivity in human babies and animal models in hearing research such as cats. To assess the effect of age in grey mouse lemurs, we determined frequency dependent auditory thresholds using tone pips in the range between 500 Hz and 95 kHz of two age groups of mouse lemurs (young animals: 1 to 5 years of age; old animals: 6 years or older). Altogether 19 animals were tested using sevoflurane for anesthesia.

Audiograms were established individually based on visually determined auditory thresholds. Findings indicate that mouse lemurs show broadband frequency sensitivity from 800 Hz to 40 kHz. Although they exhibit better hearing in the ultrasonic range than most primates, their best frequency of hearing is about 8 kHz. A significantly reduced hearing sensitivity over the complete tested frequency range was found in aged animals. Furthermore the eldest tested individual was found to be completely deaf. Long-term measurements will characterize the progress of that possible hearing loss more exactly. Thus, BERA is a promising, cost- and time-efficient technique for screening colonies of small primates, such as mouse lemurs,

for hearing capabilities and deficiencies.

Change of theta-band coherence between auditory cortex and ventral striatum in Mongolian gerbil during a two-way Go/NoGo operant conditioning task.

Andreas L Schulz, Marie L Woldeit¹, Frank W Ohl^{1,2}

¹Leibniz Institute for Neurobiology, System Physiology of Learning, Brenneckestr 6, 39118 Magdeburg, Germany

²Otto-von-Guericke University Magdeburg, FNW, IBIO, Germany

Temporal difference (TD) learning, a particular variant of reinforcement learning, has previously been used a framework to describe goal-directed behavior in animals including humans.

The biological implementation of these models assume a flow of information through cortico-striatal sensory-motor loops. Goal directed behavior emerges as a result from neural computation of the difference between predicted and actually received rewards. However, how auditory information is relayed to and processed within the ventral striatum, and how this processing interacts with processing in auditory cortex (AC) in auditory learning is largely unknown. In this study we therefore investigated the coherence between local field potentials in the AC and ventral striatum to estimate the coupling strength between these two brain structures and its dynamic development in the course of learning in a two-way active avoidance task.

Local field potentials in the auditory cortex and striatum were recorded simultaneously while animals performed a Go/NoGo operant conditioning paradigm. In a two-compartment shuttle box the animals had to learn to perform a Go response to a CS+ and a NoGo response to a CS-. Both stimuli were trains of frequency-modulated tones (1-2 kHz, rising and falling). On the occasion of misses and false alarms mild footshocks were applied. All animals acquired the task after 5 sessions, each consisted of 30 CS+ and 30 CS- trials randomly interleaved. Only the imaginary part of the coherence was regarded in order to avoid influences caused by volume conductance.

Statistical procedures confirmed that in 6 out of 8 animals coherence in the theta range was based on a conjoint neurophysiological process in both brain areas. This was only true for frequencies band below 15 Hz. Furthermore coherence measures from all animals had a positive sign, indicating that the signal in the AC leads the signal in the striatum.

Additionally, the coherence was not static, but was modulated by the rate of repetitions of the FM-tones (2 Hz) in a trial sequence. During training, the coherence of the CS+ increased significantly over sessions, whereas the coherence to the CS- remained stable. Furthermore, the difference of coherence between CS+ and CS- became significantly larger with advanced training. There was no difference of coherence found for different responses, like Go or NoGo. Nevertheless, there was a significant correlation between the coherence of the CS+ and the number of successful trials (hits).

These results show that training indeed modifies the coupling strength between AC and ventral striatum, as predicted by the TD learning framework. There are indications that the signal in the striatum follows the AC. However, coupling strength does not necessarily mean direct connections and the lack of any significant coherence above 15 Hz remains an issue to address.

Spatio-temporal coding in the bat auditory midbrain and cortex: a representation of echo-acoustic flow?

Uwe Firzlaff, Susanne Hoffmann², Alexander Warmbold², Lutz Wiegrebe²

¹Technische Universität München, Lehrstuhl für Zoologie, Liesel-Beckmann-Str. 4, 85350 Freising Weihenstephan, Germany

²LMU München, Division of Neurobiology, Dept. Biology II, Grosshaderner Str. 2, 82152 Planegg-Martinsried, Germany

For echolocating bats, spatio-temporal processing of echoes of their sonar emission is essential for detecting prey and avoiding obstacles. The high directionality of the auditory system mediated by the large sound transforming peripheral structures (ears and noseleaf) is exploited by bats to navigate through densely structured environments. Therefore, the neural coding of spatio-temporal echo information is a major function in the bat auditory system.

We investigated this function by presenting random sequences of echoes in virtual space and constructing spatio-temporal receptive fields (SPATRF) of neurons in the inferior colliculus (IC) and the dorsal fields of auditory cortex (AC) of the bat *Phyllostomus discolor*. Echoes in virtual acoustic space were generated by convolving a standard echolocation call with head-related impulse functions of this bat species and presented via earphones to anesthetized animals. Spikes were continuously recorded extracellularly during presentation of virtual echoes and used to reconstruct SPATRFs by a reverse correlation technique.

SPATRFs recorded in the IC revealed a conspicuous spatio-temporal center-surround organization with complementary arrangements of excitation and suppression. In contrast, in the AC SPATRFs only rarely showed this pattern but often contained two excitatory areas clearly separated in time and space. The spatio-temporal arrangement of these two excitatory areas was orderly distributed along the dorsal cortical surface: temporal separation increased along the rostral-caudal axis, indicating a chronotopic arrangement of call-echo delay tuned neurons as found in other bats. Interestingly, the spatial separation of the two excitatory areas roughly co-varied with temporal separation in an inverse manner. The range of spatio-temporal combinations of excitatory areas represented lateral obstacle distances between 0.2 and 1.6m, typically the range of distance maintained by bats during transfer-flight. This seems to indicate a function in processing of echo acoustic flow-field information.

The data show, that spatio-temporal echo information is differently processed in the bat IC and AC: Spatio-temporal contrast enhancement in the IC might contribute to echo-feature extraction. In the AC these features seem to be recombined to achieve a representation of space and time, which might be behaviorally relevant for the processing of echo-acoustic flow.

Amplitude-modulation detection of Gerbils in reverberant sound fields

Lutz Wiegrebe, Andrea Lingner¹, Kathrin Kugler¹, Benedikt Grothe¹

¹Department Biology II, LMU München, Division of Neurobiology, Grosshaderner Str. 2, 82152 Planegg-Martinsried, Germany

Reverberation can dramatically impair amplitude modulations (AM), critical for speech intelligibility. Psychophysical experiments indicate that humans' sensitivity to AM in reverberation is better than predicted from the effective modulation depth at the receiver position. Electrophysiological studies on reverberation in rabbits highlight the contribution of neurons sensitive to interaural correlation. Here, we quantify the Gerbils' AM sensitivity (in terms of prepulse inhibition) in both anechoic and reverberant environments. Data show first that prepulse inhibition provides a reliable method to determine the perceptual salience of AM. However, there is no evidence for perceptual recovery of AM in reverberation. The lack of recovery is explained with the gerbil's inferior perceptual sensitivity to changes in interaural correlation.

Funded by the Bernstein Center for Computational Neuroscience Munich

Projection Patterns of Neurons within the Chicken Inferior Colliculus into Formatio Reticularis and Optic Tectum

Bertram Niederleitner, Harald Luksch¹

¹Technische Universität München, Zoologie, Liesel Beckmann Straße 4, 85354 Freising, Germany

The avian midbrain is a major center for multisensorial information processing. Visual information from retinal ganglion cells reaches the Optic Tectum (TeO) in the superficial layers, while auditory information from brainstem nuclei is relayed to the TeO by the nucleus Mesencephalicus Lateralis pars dorsalis (MLd), also referred to as the Inferior Colliculus (IC). While this convergence of visual and auditory information is well-known, the circuitry has not been described in detail. Specifically, the location of the termination fields from the external nucleus of the Inferior Colliculus (ICX) to the TeO is unknown. Also, the postsynaptic (bimodal) neurons have not been identified so far. To delineate the audio-visual integration circuitry, we performed stereotactically controlled tracer applications with pressure injection *in vivo* and iontophoretic single cell labelings in slice preparations. Tracer was applied into either the ICX, the formatio reticularis between the IC and the isthmus system and into the TeO in different preparations to assess both antero- and retrograde staining patterns.

Tracer application into the ICX results in axonal labeling in two areas: The TeO and the formatio reticularis. Labeling in the TeO is rather weak and mostly restricted to tectal layer 14, where many axonal terminals are labeled. Beyond this layer, only few fibers reach towards the more superficial layers. On the course of the ICX fibers to the tectum, abundant axonal terminals are found in a second area that probably belongs to the formatio reticularis. This area is located dorsally to the isthmus system, is striated by efferent fibers from the tectum but appears to be rather compact. Neurons within this area are labeled retrogradely after TeO applications, indicating that they project upon the tectum. Because of its rather compact appearance and its projection pattern, this area might form a relay nucleus en route to the TeO, which would explain the weak ICX-TeO projection we found. We are currently investigating the projection patterns of this putative relay area with intracellular recordings in slice preparations. Our results suggest two projection pathways exist from the ICX to the TeO, a direct one and an indirect one.

With the delineation of the connections from an auditory nucleus into the optic tectum, we aim to shed light upon the putatively bimodal cell types within the latter and thus to increase our understanding of audio-visual integration in birds.

Metabolic Maturation of Auditory Neurones in the Superior Olivary Complex: Immunohistochemical Study and Mathematical Modelling

Lars Kunz, Barbara Trattner^{1,2}, Céline Marie Gravot^{1,2}, Benedikt Grothe^{1,3}

¹Ludwig Maximilians University of Munich, Division of Neurobiology, Department Biology II, Planegg-Martinsried, Germany

²Graduate School of Systemic Neurosciences, Ludwig Maximilians University of Munich, Planegg-Martinsried, Germany

³Bernstein Center for Computational Neuroscience Munich, Planegg-Martinsried, Germany

Generating action potentials is costly and a neurone's activity is directly linked to its energy consumption. Therefore, neurones generally adjust their metabolism according to their specific demands. This contribution reports alterations in neurones of auditory brainstem nuclei during postnatal development up to mature state in the Mongolian gerbil (*Meriones unguiculatus*). The issue of energy availability and consumption is important in these neurones, as they exhibit various biophysical adaptations and some of the highest firing rates in the brain to allow for fast and temporally accurate auditory processing. By means of immunohistochemistry we studied developmental changes of metabolic marker levels in the three superior olivary complex nuclei involved in precise binaural processing, i.e. the medial superior olive (MSO), the lateral superior olive (LSO) and the medial nucleus of the trapezoid body (MNTB). We found similar changes in all three nuclei investigated. The number of mitochondria, cytochrome c oxidase (COX) activity, glucose transporter 3 (GLUT3), which is the most important neuronal glucose transporter, and Na⁺/K⁺-ATPase increase before as well as after hearing onset (on postnatal day P13) and saturate once the adult stage is reached. The rise in Na⁺/K⁺-ATPase and mitochondrial number precedes the increase in GLUT3 levels and is already substantial before hearing onset, whilst GLUT3 levels are scarcely detectable before hearing onset and rise only in the refinement phase thereafter. We found also specific differences between the nuclei, e.g. in the MNTB marker development appears distinctly earlier than in the other two nuclei. We calculated the energy consumption of SOC neurones for different postnatal ages (P0-90) and firing frequencies utilising published electrophysiological and morphological parameters. The mathematical model is based on an approach established for neurones in other brain areas, which relates all neuronal processes to the regeneration of the disturbed Na⁺ gradient and the energy the Na⁺,K⁺-ATPase consumes during this process [Howarth et al. 2012, J. Cereb. Blood Flow Metab. 32:1222]. The energetic components we considered are maintenance of resting membrane potential, generation of action potentials and postsynaptic excitatory currents since those have been shown to be the most prominent components in other neurons and are closely related to the postsynaptic localisation of the metabolic markers we have quantified. The calculated results reflect well the developmental time course of metabolic marker levels and reaches saturation for all three nuclei. In MSO and LSO, energy consumption rises both before and substantially after hearing onset. The speciality of the MNTB was also observed in calculated energy consumption, which exhibits an earlier onset and a larger fraction of rise before hearing onset in accordance with an earlier maturation of MNTB. In summary, our study shows that energetically relevant markers develop not only before hearing onset but also in a refinement period thereafter, when stimulus evoked auditory activity might be a further cue for maturation. The developmental changes in energy consumption obtained by means of a mathematical model closely resemble those of markers for energy consumption (Na⁺,K⁺-ATPase levels) and production (number of mitochondria, COX activity and GLUT3 levels).

Lack of brain-derived neurotrophic factor in the cochlea but not in the brain hampers inner hair cell synapse physiology, but protects against noise induced afferent fiber loss.

Wibke Singer, Annalisa Zuccotti¹, Stephanie Kuhn², Stuart L. Johnson², Christoph Franz¹, Dietmar Hecker³, Hyun-Soon Geisler¹, Iris Köpschall¹, Karin Rohbock¹, Katja Gutsche⁴, Julia Dlugaiczyk³, Bernhard Schick³, Walter Marcotti², Lukas Rüttiger¹, Thomas Schimmang⁴, Marlies Knipper¹

¹University of Tübingen, Molecular Physiology of Hearing, THRC, Elfriede-Aulhron-Str. 5, 72076 Tübingen, Germany

²Department of Biomedical Science, University of Sheffield, S10 2TN, Sheffield, UK

³Department of Otorhinolaryngology, Saarland University Hospital, Kirrberger Straße, 66421 Homburg/Saar, Germany

⁴Instituto de Biología y Genética Molecular, Universidad de Valladolid y Consejo Superior de Investigaciones Científicas, E-47003 Valladolid, Spain

The precision of sound information transmitted to the brain depends on the transfer characteristics of the inner hair cell (IHC) ribbon synapse and its multiple contacting auditory fibers. We found that brain derived neurotrophic factor (BDNF), so far assumed to maintain spiral ganglia neuron survival, differentially influences IHC characteristics in the intact and injured cochlea. Using conditional knockout mice (BDNF^{Pax2} KO) we found that resting membrane potentials, membrane capacitance and resting linear leak conductance of adult BDNF^{Pax2} KO IHCs showed a normal maturation. Likewise, in BDNF^{Pax2} KO membrane capacitance (ΔC_m) as a function of inward calcium current (I_{Ca}) follows the linear relationship typical for normal adult IHCs. In contrast the maximal ΔC_m , but not the maximal size of the calcium current, was significantly reduced in high frequency but not low frequency cochlear turns correlated with a loss of IHC ribbons in these turns and a reduced activity of the auditory nerve (ABR wave I). Remarkably, a noise-induced loss of IHC ribbons, followed by reduced activity of the auditory nerve and reduced centrally generated wave II and III observed in control mice, was prevented in equally noise-exposed BDNF^{Pax2} KO mice. This did not occur when BDNF was deleted in a mouse model that lead to deletion of BDNF in central brain neurons. Data describe a differential beneficial and harmful role of BDNF in the intact, respectively injured cochlea with dramatic impact on central sound processing that are discussed in a more widespread context of brain disorders.

Supported by a grant from the Marie Curie Research Training Network CavNET MRTN-CT-2006-035367, Deutsche Forschungsgemeinschaft, grant DFG-Kni316-8-1

Poster Topic

T19: Chemical Senses: Olfaction, Taste, Others

- T19-1A** Odor identity coding reveals parallel processing within the bee's dual olfactory pathway
Martin F. Brill, Anneke Meyer, Martin P. Nawrot, Wolfgang Rössler
- T19-2A** Characterization and Role of Calcium-Dependent Potassium Currents in Local Interneurons of the Antennal Lobe of *Periplaneta Americana*.
Ben Warren, Cathleen Rotte, Sabine Schleicher, Andreas Klein, Viktor Bardos, Sandra Wendler, Merit Klemann, Peter Kloppenburg
- T19-3A** Information processing in the *Drosophila* Olfactory System: From Odors to Kenyon cells
Faramarz Faghihi, Florentin Wörgötter, Christoph Kolodziejcki
- T19-4A** On the Importance and Interaction of Visual and Olfactory Signals in Honeybee Foraging Behaviour
Verena Reinhardt, Christa Neumeyer
- T19-5A** *In situ* voltage-clamp recordings from olfactory projection neurons in the honeybee
Jan Kropf, Wolfgang Rössler
- T19-6A** Transduction of amino acid odorants in the main olfactory epithelium of larval *Xenopus laevis*
Alfredo Sansone, Thomas Hassenklöver, Evangelia Tantalaki, Ivan Manzini
- T19-7A** Phospholipase C β mediates pheromone-dependent signal transduction in the olfactory receptor neurons of the hawkmoth *Manduca sexta*
Petra Gawalek, Andreas Nolte, Martin Hindermann, Monika Stengl
- T19-8A** Mitochondrial Ca²⁺ mobilization plays a key role in mouse olfactory signaling
Lisa Marie Moeller, Daniela Fluegge, Annika Cichy, Monika Gorin, Agnes Weth, Sophie Veitinger, Silvia Cainarca, Stefan Lohmer, Sabrina Corazza, Eva M. Neuhaus, Werner Baumgartner, Jennifer Spehr, Marc Spehr
- T19-9A** Profile of Ectopically Expressed Human Olfactory Receptors
Caroline Flegel, Stavros Manteniotis, Sandra Osthold, Guenter Gisselmann, Hanns Hatt
- T19-10A** The insect olfactory system exploits stimulus-onset asynchrony for odor-background segregation
Paul Szyszka, Jacob S. Stierle, Stephanie Biergans, C. Giovanni Galizia
- T19-11A** Octopaminergic Neuromodulation in the Cockroach Antennal Lobe.
Cathleen Rotte, Malaika Fehlert, Peter Kloppenburg

- T19-12A** The expression patterns of odorant binding proteins and receptors indicate distinct subsets of olfactory sensilla on the antenna of *Anopheles gambiae*
Anna Schultze, Danuta Schymura, Jürgen Krieger
- T19-13A** Cloning and expression pattern of a GABAB-receptor subunit from the antennae of male *Heliothis virescens*
Pablo Pregitzer, Heinz Breer, Jürgen Krieger
- T19-14A** Comprehensive RNA-Seq Expression Analysis of Sensory Neurons with Focus on Trigeminal Ganglia
Stavros Manteniotis, Ramona Lehmann, Caroline Flegel, Benjamin Schreiner, Janine Altmüller, Nicole Schöbel, Hanns Hatt, Guenter Gisselmann
- T19-15A** Putative chemosensory cells at the “limiting ridge” and their interaction with “effector” cells
Julia Eberle, Patricia Widmayer, Heinz Breer
- T19-16A** Electrophysiological investigation of intrinsic mitral cell properties in the mouse accessory olfactory bulb
Monika Gorin, Marc Spehr
- T19-17A** Benchmarking *Drosophila* receptor neurons for technical applications
Thomas Nowotny, Stephen Trowell, Marien de Bruyne
- T19-18A** Function of adult-generated dopaminergic interneurons in the olfactory bulb glomerular layer
Wolfgang Georg Bywalez, Michael Mörschel, Philipp Serr, Jovica Ninkovic, Magdalena Götz, Veronica Egger
- T19-19A** Dominance of weaker ligands in a complex odor mixture
Daniel Münch, Benjamin Schmeichel, Ana F. Silbering, C. Giovanni Galizia
- T19-20A** Modulation of pheromone responses in antennal trichoid sensilla of the hawkmoth *Manduca sexta* by Orco agonism and antagonism
Andreas Nolte, Nico Funk, Latha Mukunda, Petra Gawalek, Sarah Körte, Dieter Wicher, Bill S. Hansson, Monika Stengl
- T19-1B** Role of the Global Lateral Inhibition in the Olfactory Bulb Network and Discrimination Time in Mice
Daniel Nunes, Thomas Kuner
- T19-2B** Functional properties of oligomeric constructs of the *Drosophila* odorant co-receptor Orco
Latha Mukunda, Vardanush Sargsyan, Sofia Lavista-Llanos, Bill S. Hansson, Dieter Wicher
- T19-3B** Mammalian specific OR37 receptors are differentially activated by distinct odorous fatty aldehydes
Verena Bautze, Wolfgang Schwack, Heinz Breer, Jörg Strotmann
- T19-4B** Circadian oscillations of cyclic nucleotide concentrations in insect antennae
Thomas Schendzielorz, Katja Schirmer, Julia Schulze, Monika Stengl

- T19-5B** Characterization and Role of Ca²⁺ - Dependent Outward Potassium Currents in Uniglomerular Projection Neurons of the Antennal Lobe of *Periplaneta americana*.
Sabine Schleicher, Cathleen Rotte, Ben Warren, Andreas Klein, Viktor Bardos, Peter Kloppenburg
- T19-6B** Sugar-elicited search behavior: the blowfly's dance in honey bees
Axel Brockmann, Andrew Magis, Jake Herman, Jonathan Massy, Gene E. Robinson
- T19-7B** Citral selectively inhibits human K_{2P}3.1 channels
Leopoldo Raul Beltran
- T19-8B** Neurochemical profiles of identified local interneurons in the antennal lobe of *Periplaneta americana*
Debora Fusca, Andreas Husch, Joachim Schachtner, Arnd Baumann, Peter Kloppenburg
- T19-9B** Functional characterization of human trace amine-associated receptors (TAARs) in recombinant systems.
Ivonne Wallrabenstein, Jonas Kuklan, Lea Weber, Sandra Zborala, Markus Werner, Janine Altmüller, Christian Becker, Anna Schmidt, Hanns Hatt, Thomas Hummel, Günter Gisselmann
- T19-10B** Role of G_{αo/i} subgroup of G proteins in olfactory signaling of *Drosophila melanogaster*
Jennifer Sinthiya Ignatious Raja, C. Giovanni Galizia, Vladimir L Katanaev
- T19-11B** Deep Sequencing of the Murine Olfactory Transcriptome
Ninthujah Kanageswaran, Marilen Demond, Benjamin Schreiner, Janine Altmüller, Hanns Hatt, Günter Gisselmann
- T19-12B** Long-term effects of noradrenaline on olfactory sensory neuron input to the main olfactory bulb.
Dennis Eckmeier, Stephen D Shea
- T19-13B** Electrophysiological characterization of proton-mediated activity in the mouse vomeronasal organ
Annika Cichy, Jennifer Spehr, Marc Spehr
- T19-14B** Can *Aedes aegypti* females avoid oviposition on *m*-cresol (100 ppm) in the presence of the deterrent isomer *p*-cresol?
Ali Afify, Giovanni C. Galizia
- T19-15B** Altered expression of gustatory signaling elements in the stomach of morbidly obese patients and obese mice
Patricia Widmayer, Markus Küpper, Michael Kramer, Alfred Königsrainer, Heinz Breer
- T19-16B** Phenotypic plasticity of synaptic-bouton numbers in the mushroom bodies of the highly polymorphic leaf-cutting ant *Atta vollenweideri*
Claudia Groh, Christina Kelber, Kornelia Grübel, Wolfgang Rössler

- T19-17B** Deorphanizing crypt neurons, the third type of olfactory receptor neurons
Gaurav Ahuja, Yuichiro Oka, Sigrun Korsching
- T19-18B** Identification of a new murine olfactory subsystem
Sonja Oberland, Stefanie Gaab, Niels de Wit, Thomas Pelz, Eva M. Neuhaus
- T19-19B** Comparative transcriptomics of arthropod antennae
Katrin Christine Groh, Ewald Grosse-Wilde, Heiko Vogel, Marcus C. Stensmyr, Bill S. Hansson
- T19-20B** Vinegar fly behavior towards odor mixtures – an additive approach
Michael Thoma, Markus Knaden, Bill S. Hansson
- T19-21B** Receptors for protein breakdown products in gastric endocrine cells and in gustatory sensory cells
Désirée Haid, Patricia Widmayer, Heinz Breer
- T19-1C** Serotonin association with feeding regulation in ants
Agustina Falibene, Roxana Josens, Wolfgang Rössler
- T19-2C** Molecular basis of sex pheromone detection in *Heliothis virescens*
Jürgen Krieger, Pablo Pregitzer, Heinz Breer
- T19-3C** Spatial representation of the olfactory output in *Drosophila*
Amelie E. E. Baschwitz, Antonia Strutz, Bill S. Hansson, Silke Sachse
- T19-4C** Identification of PDZ-protein based microdomains in vomeronasal sensory neurons
Bastian Henkel, Tobias Ackels, Marc Spehr, Eva M. Neuhaus
- T19-5C** Chemo- and thermosensory signaling in the Grueneberg ganglion
Joerg Fleischer, Katharina Mamasuew, Sabrina Stebe, Heinz Breer
- T19-6C** Tachykinin-related and myoinhibitory peptides co-express in the brain of *Tribolium castaneum*
Milosz Krala, Carsten M. Heuer, Joachim Schachtner
- T19-7C** The *Drosophila melanogaster* olfactory co-receptor Orco mediates odorant sensitivity in adult flies
Thomas Tam Giang, Andrea Schneider, Henrike Scholz
- T19-8C** Functional characterization of alternative signal transduction pathways in olfactory receptor neurons
Paul Scholz, Sabrina Baumgart, Katharina Klasen, Benjamin Kalbe, Hanns Hatt
- T19-9C** Scaffolding proteins in olfaction
Fabian Jansen, Sabrina Baumgart, Benjamin Kalbe, Mark Spehr, Christian Herrmann, Willem Bintig, Hanns Hatt, Eva Neuhaus
- T19-10C** Delta-gamma phase-amplitude coupling in the mouse whisker barrel cortex is driven by the

olfactory bulb

Junji Ito, Snigdha Roy, Ying Cao, Max Fletcher, Sonja Grün, Detlef Heck

- T19-11C** Untypical connectivity from olfactory sensory neurons expressing OR37 into higher brain centers visualized by genetic tracing
Jörg Strotmann, Andrea Bader, Heinz Breer
- T19-12C** Characterization of the Iontransporter NKCC1 in the Field of Chemosensation
Claudia Haering, Janine Wäring, Hanns Hatt
- T19-13C** Variation in the human olfactory subgenome and its impact on olfactory perception
Jonas Kuklan, Günter Gisselmann, Thomas Hummel, Hanns Hatt
- T19-14C** Involvement of several TRP channels in trigeminal odor sensation
Jessica Kyereme, Matthias Lübbert, Nicole Schoebel, Hanns Hatt
- T19-15C** Taste Receptors in mammalian Spermatozoa: Functional role of Tas1r1 in regulating basal Calcium and cAMP concentrations in Spermatozoa
Andrea Wartenberg, Dorke Meyer, Anja Voigt, Patricia Widmayer, Heike Borth, Andreas Breit, Ulrich Boehm, Thomas Gudermann, Wolfgang Meyerhof, Ingrid Boekhoff
- T19-16C** Deorphanization of members of the segregating pseudogenes of olfactory receptors
Kaveh Ashti Baghaei, Günter Gisselmann, Hanns Hatt
- T19-17C** Probing a potential heteromultimerization of recombinant anoctamin proteins
Tobias Ackels, Bastian Henkel, Eva Neuhaus, Marc Spehr
- T19-18C** An *in vivo* Atlas of the *Drosophila* Antennal Lobe based on Receptor Neuron Targeting
Veit Grabe, Antonia Strutz, Bill S. Hansson, Silke Sachse
- T19-19C** A model for sparse and reliable encoding of olfactory cues in the honeybee
Rinaldo Betkiewicz, Michael Schmucker, Farzad Farkhooi, Martin Paul Nawrot
- T19-20C** Gene expression profiling and the olfactory sense of *Manduca sexta*
*Christopher Koenig, Sascha Bucks, Monika Stengl, Heiko Vogel, Ewald Grosse-Wilde, Bill S Hansson**
- T19-21C** Effects of adiponectin on the olfactory system
Diana Loch, Heinz Breer, Jörg Strotmann
- T19-1D** FMRFamide-immunostaining reveals SIFamide in the antennal lobe of the honeybee
Sabine Kreissl, Anne Schapals, Giovanni C. Galizia
- T19-2D** Post-stimulus activity in the olfactory pathway of *Drosophila*
Alja Lüdke, Kristina Dylla, C. Giovanni Galizia, Paul Szyszka
- T19-3D** The neglected sense - Olfactory Communication in a songbird, the Zebra Finch (*Taeniopygia guttata*)

- T19-4D** SPLITGFP - MEDIATED LOCALIZATION OF CONNECTIVITIES BETWEEN INTRINSIC AND EXTRINSIC MUSHROOM BODY NEURONS IN *DROSOPHILA*
Ulrike Pech, Atefeh Pooryasin, Serge Birman, André Fiala
- T19-5D** Comparative neuroanatomical study of the antennal lobes of hornets.
Antoine Couto, Karine Monceau, Olivier Bonnard, Denis Thiéry, Jean-Christophe Sandoz
- T19-6D** Pheromonal sex communication in honeybee drones: from odor processing to orientation behavior
Andreas S. Brandstaetter, Florian Bastin, Jean-Christophe Sandoz
- T19-7D** Activity Dependent Plasticity in the Olfactory System of Adult *Tribolium castaneum*
Peter Christ, Martin Kollmann, Joachim Schachtner
- T19-8D** Inhibitory projection neurons bias odor attraction behavior in the lateral horn area of *Drosophila melanogaster*
Antonia Strutz, Jan Soelster, Amelie Baschwitz, Veit Grabe, Farhan Abu , Jürgen Rybak, Markus Knaden, Michael Schmucker, Bill S. Hansson, Silke Sachse
- T19-9D** The olfactory pathway of the red flour beetle *Tribolium castaneum*
Martin Kollmann, Stefan Dippel, Sergius Frank , Stephanie Crombach , Stefan Schütz , Ernst A. Wimmer , Joachim Schachtner
- T19-10D** Key Players – Functional analysis of *Manduca sexta* Olfactory Receptors
Christian Klinner, Christopher König, Shannon Olsson, Marcus C. Stensmyr, Bill S. Hansson, Ewald Grosse-Wilde
- T19-11D** Olfaction in the jumping bristletail *Lepismachilis y-signata*(Archaeognatha, Machilidae)
Christine Mißbach, Hany Dweck, Steffen Harzsch, Marcus C. Stensmyr, Markus Knaden, Bill S. Hansson, Ewald Grosse-Wilde
- T19-12D** The neuropeptidome of *Tribolium castaneum* antennal lobes and mushroom bodies
Marlene Binzer, Carsten M. Heuer, Jörg Kahnt, Joachim Schachtner
- T19-13D** Coding of floral and pheromonal odors by two olfactory subsystems in the honeybee brain
Jean-Christophe Sandoz, Julie Carcaud, Martin Giurfa
- T19-14D** Synaptic circuitry of identified neurons in the antennal lobe of *Drosophila melanogaster*
Jürgen Rybak, Giovanni Talarico, Santiago Ruiz, Christopher Arnold, David Neubert, Rafael Cantera, Bill Hansson
- T19-15D** Bimodal processing of olfactory information in an amphibian nose: Odor responses segregate into a medial and a lateral stream
Sebastian Gliem, Adnan S. Syed, Alfredo Sansone, Eugen Kludt, Evangelia Tantalaki, Sigrun I. Korsching, Ivan Manzini
- T19-16D** Rapid maturation of odor-evoked signaling in adult-born juxtglomerular neurons of the

mouse olfactory bulb.

Yury Kovalchuk, Ryota Homma, Yajie Liang, Anatoliy Maslyukov, Marina Hermes, Yovica Ninkovic, Magdalena Götz, Lawrence Cohen, Olga Garaschuk

T19-17D Olfactory related gene expression in the antenna of leaf-cutting ants (*Atta vollenweideri*).
Sarah Koch, Bill S. Hansson, Christoph J. Kleineidam, Ewald Grosse-Wilde

T19-18D SHORT-TIME EXPOSURE TO VARIOUS ODOR STIMULI OR ODOR DEPRIVATION AFFECTS THE DISTRIBUTION OF FOS POSITIVE CELLS IN THE OLFACTORY SYSTEM NEUROGENIC AREA OF THE RAT
Kamila Fabianova, Juraj Blasko, Marcela Martoncikova, Eriko Racekova

T19-19D Post-stimulus firing and the corresponding olfactory search strategy
Nicole Voges, Antoine Chaffiol, Philippe Lucas, Dominique Martinez

Odor identity coding reveals parallel processing within the bee's dual olfactory pathway

Martin F. Brill, Anneke Meyer², Martin P. Nawrot², Wolfgang Rössler¹

¹University of Würzburg, Biozentrum, Behavioral Physiology and Sociobiology (Zoology II), Am Hubland, 97074 Würzburg, Germany

²Freie Universität Berlin, Institut of Biology, Neuroinformatics and Theoretical Neuroscience, Koenigin Luise Str. 1-3, 14195 Berlin, Germany

In their natural environment animals are faced with complex and highly dynamic olfactory input. This demands fast and reliable information processing in olfactory systems of both vertebrates and invertebrates. Parallel processing was shown to improve processing speed and power in the auditory, visual, and somatosensory system and is characterized as extraction of different parameters along parallel sensory information streams. For instance, in the visual system the magno- and parvocellular pathways from the lateral geniculate nucleus mediate different elemental properties of the same visual scene such as color and spatio-temporal patterns (Livingstone & Hubel, 1988 *Science* 240:740-749). Honeybees possess an elaborate olfactory system with unique neuronal architecture, a dual olfactory pathway comprising a medial and lateral projection-neuron (PN) output tract (m-, l-APT) connecting the olfactory lobes with higher order brain centers. This peculiarity is exclusively found in Hymenoptera (e.g. bees, ants, wasps; Rössler & Zube, 2011 *Arthropod Struct Dev* 40:349-357). Here, we used this specific adaptation as a model system to address the importance of parallel processing in olfaction.

We employed a novel experimental technique for simultaneous multi-unit recordings from both antennal-lobe output tracts. This revealed detailed response profile characteristics of high numbers of PNs to a variety of floral, pheromonal and biologically relevant odors. PNs of both tracts responded to all tested odors, but with different characteristics indicating parallel processing. L-APT PNs were activated by multiple odors (broad response profiles) suggesting generalized odor coding, whereas m-APT PNs responded with sparse activity pattern and high odor-specificity. Comparison of response latencies of PNs within and across both output streams revealed odor-dependent latency patterns that likely support a dual tract temporal code, possibly promoting coincidence coding at the level of the mushroom body input, which could have important implications for olfactory learning and memory (e.g. Heisenberg, 2003 *Nat Rev Neurosci* 4:266–275).

We conclude that parallel processing via the honeybee's dual olfactory pathway enhances performance for sophisticated odor perception as required under complex natural stimulus conditions of a social insect. Comparison with recent work on olfactory systems in rodents (e.g. Igarashi, Ieki et al., 2012 *J Neurosci* 32:7970–7985) indicates that parallel processing of olfactory output might be a common principle across distant taxa.

Supported by DFG SPP 1392 (RO 1177/5-1) and BMBF (01GQ0941).

Characterization and Role of Calcium-Dependent Potassium Currents in Local Interneurons of the Antennal Lobe of *Periplaneta Americana*.

Ben Warren, Cathleen Rotte¹, Sabine Schleicher¹, Andreas Klein¹, Viktor Bardos¹, Sandra Wendler¹, Merit Klemann¹, Peter Kloppenburg¹

¹Biocenter, Institute for Zoology, Center for Molecular Medicine (CMMC), and Cologne Excellence Cluster on Cellular Stress Responses in Aging-Associated Diseases (CECAD), University of Cologne, Germany

The antennal lobe (AL) of the cockroach is the first synaptic relay which processes olfactory information and serves as a model to study olfactory processing in general. Olfactory sensory neurons from the antennae collate, by receptor type, and provide receptor specific sensory input to each glomerulus of the AL. Local interneurons (LNs) provide excitatory and inhibitory interactions between the glomerular pathways and help to shape the tuning profile of the projection neurons. Disruption of LN signaling leads to impairment in olfactory processing and olfactory learning. In the cockroach *Periplaneta americana* at least three distinct main types of local interneurons, have so far been identified.

Calcium-dependent potassium currents ($I_{K(Ca)}$) have a key role in controlling intrinsic electrophysiological properties of neurons. Here we analysed $I_{K(Ca)}$ in three distinct classes of LNs and started to investigate the effect of $I_{K(Ca)}$ on their intrinsic electrophysiological properties by occlusion experiments. Firstly we isolated $I_{K(Ca)}$ using appropriate voltage protocols and pharmacological blockers to analyse its kinetics and its calcium and voltage dependence. We found that $I_{K(Ca)}$ is distinctive in all three types of LNs.

How do these currents affect the spiking behavior of the type I LNs and the membrane potential of the non-spiking type II LNs? In an effort to characterize and selectively block different channels that collectively contribute to $I_{K(Ca)}$ we determined the concentration-response relations of three established K_{Ca} channel blockers on $I_{K(Ca)}$. We found that apamin, which blocks the small conductance (SK) channels in every other system so far studied, had no effect on $I_{K(Ca)}$. However, charybdotoxin, which mainly blocks big conductance (BK) and intermediate conductance (IK) channels, completely blocked $I_{K(Ca)}$, while the more specific big conductance (BK) channel blocker iberiotoxin only blocked up to 50% of $I_{K(Ca)}$. We have started occlusion experiments, in which portions of $I_{K(Ca)}$ were pharmacologically blocked, to better understand the functional role of $I_{K(Ca)}$ in shaping the electrophysiological properties of LNs.

This work was supported by the DFG grant KL 762/5-1 to P.K. and a Humboldt Research Fellowship awarded to B.W.

Information processing in the *Drosophila* Olfactory System: From Odors to Kenyon cells

Faramarz Faghihi, Florentin Wörgötter¹, Christoph Kolodziejski¹

¹Bernstein Center for Computational Neuroscience, Institute of physics ,Göttingen University, Germany, Department of Computational Neuroscience, Friedrich-Hund Platz 1, 37077 Göttingen, Germany

Insect navigation in natural environments, for instance to seek food or to find a mate of the same species, relies on the efficiency of the insects' olfactory system to detect, memorize, associate and retrieve olfactory information. The olfactory system of *Drosophila* (including Antennal Lobe and the Mushroom Body) consists only around 3000 neurons (Newquist, 2011) and is thus an ideal model to study the information processing of learning and memory (Masse et al. 2009). Although the system is very simple, experimentally assessing all parameters is still very difficult if not impossible. An important example for information processing is the threshold of coincidence detection in Mushroom Body neurons, the so called Kenyon cells. Here, coincidence detection means that a neuron can detect the occurrence of timely simultaneous but spatially separate input signals. In computational studies (Nowotny et al., 2003; Smith et al., 2008) the number of coincidentally active input neurons that suffice to trigger Kenyon cell firing (i.e. the threshold) is usually set arbitrarily and to our knowledge there exists only one study that addresses this question theoretically (Huerta and Garcia-Sanchez, 2003). As Kenyon cells are involved in associative odor learning (Galili et al., 2011), a detailed understanding of their function and parameters is advantageous for a better understanding of learning and memory in *Drosophila*.

The quality of information processing in a computational model of the olfactory system can give us a lead on physiological and structural parameters of this system. For this purpose we used an information theoretical measure, the mutual information, which relates to the capacity of information transmission (Paninski, 2003). The greater the mutual information between, for instance, the presented odors and the Kenyon cells, the more information about the presented odor(s) is in the Kenyon cell firing and, thus, the more efficacious is the information processing. We modeled the olfactory system with experimentally verified parameters and the environment in such a way that the system has to rely on the discrimination of distinct odors. The results show the dependency of mutual information on connectivity rate between Projection neurons and Kenyon cells as well as on coincidence detection threshold. Moreover, it shows that Normalization neurons (Papadopoulou et al., 2011) can increase the amount of mutual information for all connectivity. Normalization makes the system less dependent on the local connectivity and more robust to inter fly variation and, furthermore, to variation in odor concentration in the environment.

This study shows the potential of using mutual information to extract basic structural and functional properties of such sensory systems.

Acknowledgements

This research was supported by the BMBF-funded BCCN Göttingen with grant number 01GQ1005A, project B5.

References

- Galili SD, Ludke A, Galizia CG, Szyszka P, Tanimoto H. Olfactory Trace Conditioning in *Drosophila*. *Journal of Neuroscience* 31(20): 7240-48, 2011.
- Huerta R, Garcia-Sanchez M. Design parameters of the fan-out phase of sensory systems. *Journal of Computational Neuroscience* 15(1): 5-17, 2003.
- Masse NY, Turner GC, Jefferis GS. Olfactory information processing in *Drosophila*. *Current Biology* 19(16): R700-13, 2009.
- Newquist G. Brain organization and the roots of anticipation in *Drosophila* olfactory conditioning. *Neuroscience Biobehavioral Review* 35(5): 1166-74, 2011.
- Nowotny T, Rabinovich MI, Huerta R, Abarbanel HD. Decoding temporal information through slow lateral excitation in the olfactory system of insects. *Journal of Computational Neuroscience* 15(2): 271-81, 2003.
- Paninski L. Estimation of Entropy and Mutual Information. *Neural Computation* 15: 1191–1253, (2003).
- Smith D, Wessnitzer J, Webb B. A model of associative learning in the mushroom body *Biological Cybernetics*, 99(2): 89-103, 2008.
- Szyszka P, Galkin A, Menzel R. Associative and non-associative plasticity in Kenyon cells of the honeybee mushroom body. *Frontiers in Systems Neuroscience* 2 (2008).

On the Importance and Interaction of Visual and Olfactory Signals in Honeybee Foraging Behaviour

Verena Reinhardt, Christa Neumeyer²

¹Johannes Gutenberg-Universität Mainz, Abteilung III - Neurobiologie, Colonel Kleinmann-Weg 2, 55128 Mainz , Germany

Flowers display various colours and scents in order to attract honeybees. How these cues are learned, remembered and used in pollination by the bees was up to date unclear, as previous research approaches yielded contradictory results. Also, the difficulty of finding experimental set-ups in which colour and scent signals can be equally well presented to and learned by the bees, has discouraged many researchers from attempting to solve these questions.

This project presents the first systematic long-term exploration of the relationship and connection between visual and olfactory signals in honeybee pollination, conducted as a behavioural approach with free-flying forager bees. In order to stay as close as possible to natural conditions, honeybees were trained and tested in the open, on colours which flowers frequently use to attract them, and on natural essential oils of flowers they typically pollinate.

Our results show that bees can discriminate between two different colour stimuli, even if they are associated with the same scent; and also, that bees can discriminate between two different scents, even if they are attached to the same colour.

In the next experiment, bees were trained to a combined colour-scent stimulus and afterwards tested with conflicting stimuli, so that the previously rewarded colour was combined with a new scent, and the previously rewarded scent was combined with a new colour. Choice rates were used to determine which factor was more important to bees, and whether choice rates changed after more training.

Finally, this study explored whether a bee's preference of scent over colour (or vice versa) is reversible. Bees underwent training and conflict testing; those who preferred colour were afterwards trained on scent stimuli alone, and those who preferred scent were trained on colour stimuli alone. All those bees were afterwards conflict-tested again to check for changes in their preference.

The current study yielded some surprising insight into the strategies honeybees are using in pollination, and into the astounding behavioural plasticity their brains are capable of.

In situ voltage-clamp recordings from olfactory projection neurons in the honeybee

Jan Kropf, Wolfgang Rössler¹

¹University of Würzburg, Biozentrum, Zoology II, Am Hubland, D-97074 Würzburg, Germany

Olfaction is a crucial sense for honeybees (*Apis mellifera*), as they rely on olfactory cues to find nectar sources and to communicate within the hive. Odor information is transmitted into the first central relay station, the antennal lobe (AL), via olfactory sensory neurons (OSNs), which synapse on local interneurons and projection (output) neurons (PNs). PNs convey the olfactory message to the mushroom bodies (MBs), higher sensory association centres and sites associated with learning and memory. In honeybees, two sets of uniglomerular PNs project to the MBs via two parallel, anatomically distinct tracts, the medial and the lateral antennal lobe protocerebral tract (m- and l-APT). This dual olfactory pathway represents a special feature in Hymenoptera that most likely serves parallel processing of olfactory information (Galizia and Rössler, 2010, *Annu Rev Entomol*). The anatomy of the dual olfactory pathway is well described in honeybees; l-APT PNs receive input from glomeruli in the upper half of the AL, m-APT PNs from glomeruli in the lower half of the AL. The target regions of m- and l-APT PNs in the olfactory parts of the MBs are partly segregated (Kirschner *et al.*, 2006, *J Comp Neurol*). Parallel processing is a phenomenon well known and studied in other sensory systems, however its function and underlying mechanisms in odor coding are much less understood. Several physiological studies using calcium imaging, single cell and multi-unit recordings approached functional aspects of the dual olfactory pathway in honeybees. So far, one can conclude that both tracts largely overlap in their odor response range, but distinct differences were found in coding of olfactory information. Odor response patterns of the m-APT are more odor specific and sparser than the l-APT response patterns (see Poster M. Brill *et al.*). This might be due to either differences in the synaptic connectivity of m- and l-APT neurons within the AL, different intrinsic properties of PNs from the two tracts, or a combination of both. In the present study we set out to investigate whether m- and l-APT PNs differ in their intrinsic properties, e.g. their ion channel composition. Using a new experimental approach, we conducted *in situ* whole cell voltage-clamp recordings from PN cell bodies in intact brain preparations. The cell bodies of the PNs are clustered around the AL and easily accessible after desheathing of the brain. However, it is not possible to distinguish between cell bodies of PNs and those of local interneurons. To be able to selectively *in situ* patch-clamp record from PNs, we injected dextran-coupled tetramethyl-rhodamine (MircrorubyTM) into the mushroom bodies to let the dye be transported retrogradely along PN neurites. Using a fluorescence microscope we were able to detect and selectively record from stained cell bodies of PNs. Using selective labelling of the m- and l-APT as well as anatomical identification of distinct groups of cell bodies, selective recordings from either l- or m-APT PNs are possible. In the first experiments, typical ionic currents, i.e. fast sodium currents, A-type potassium currents and sustained potassium currents similar to those recorded from cultured honeybee AL neurons (Grünewald, 2003, *J Exp Biol*) could be observed. In a next step we aim to identify and characterize potassium and calcium currents in the two subsets of PNs.

Supported by DFG SPP 1392

Transduction of amino acid odorants in the main olfactory epithelium of larval *Xenopus laevis*

Alfredo Sansone, Thomas Hassenklöver^{1,2}, Evangelia Tantalaki^{1,2}, Ivan Manzini^{1,2}

¹Department of Neurophysiology and Cellular Biophysics, University of Göttingen, Humboldtallee 23, 37073 Göttingen, Germany

²DFG Research Center for Molecular Physiology of the Brain (CMPB), University of Göttingen, Humboldtallee 23, 37073 Göttingen, Germany

The main olfactory epithelium (MOE) of larval *Xenopus laevis* contains at least two subsets of olfactory receptor neurons (ORNs). One subset mainly consists of ciliated ORNs, is characterized by responses to alcohols, aldehydes and ketones and is endowed with the canonical cAMP-mediated transduction pathway. The second subset mainly consists of microvillous ORNs, is characterized by amino acid responses and uses an unknown cAMP-independent transduction cascade. Here we set out to investigate this alternative pathway using the calcium imaging technique in acute slices of the MOE. Application of amino acid odorants elicited calcium transients that were dependent on the presence of extracellular Ca^{2+} , i.e. the responses were abolished in Ca^{2+} -free environment. Conversely, depletion of the intracellular Ca^{2+} stores did not impair the amino acid responsiveness of these ORNs. Pharmacological inhibition of phospholipase C (PLC), via the widely used blocker U-73122, led to a strong and reversible reduction of the amino acid-induced responses. A weakly active analogue of the blocker, used as a control, did not show a comparable response reduction. Furthermore, the PLC inhibitor specifically suppressed only amino acid-sensitive ORNs, since under blocking conditions forskolin as well as odorants other than amino acids, still elicited large calcium responses in other ORNs of the same MOE slices. 2-APB and SKF-96365, two inhibitors that have been shown to affect TRPC2 channels in mammalian vomeronasal receptor neurons, also suppressed amino acid-induced responses in *Xenopus*.

Taken together, the present study provides evidence that amino acid-sensitive ORNs in the MOE of larval *Xenopus laevis* possess a PLC-dependent transduction pathway. Further studies will be needed to conclusively demonstrate the involvement of TRPC2 channels in this transduction cascade.

[Supported by DFG Schwerpunktprogramm 1392 (I.M.) and DFG Research Center Molecular Physiology of the Brain (I.M.)]

Phospholipase C β mediates pheromone-dependent signal transduction in the olfactory receptor neurons of the hawkmoth *Manduca sexta*

Petra Gawalek, Andreas Nolte¹, Martin Hindermann¹, Monika Stengl¹

¹Animal Physiology, University of Kassel, Heinrich-Plett-Straße 40, 34132 Kassel, Germany

In male moths sex pheromones elicit stereotypic searching behavior at astoundingly low concentrations as well as over a broad concentration range. Furthermore, the sensitivity of the olfactory system is daytime-dependently controlled. It changes with the physiological state of the crepuscular moth, which sleeps during the day and is most active in the evening and the early morning. Insect olfactory transduction mechanisms which underlie olfactory receptor-dependent potential changes controlling action potential activity of the olfactory receptor neurons (ORNs) are still under lively debate. For different moths evidence is provided that pheromone-binding activates a phospholipase C β (PLC β) which produces inositol-trisphosphate (IP₃) and diacylglycerol (DAG) leading to Ca²⁺-influx. In fruitflies an ionotropic odor transduction mechanism is suggested. Odor-binding to the olfactory receptor (OR) is assumed to open a channel pore formed by the OR with a conserved ubiquitous co-receptor (Orco). With extracellular tip recordings from pheromone-sensitive trichoid sensilla of intact male *Manduca sexta* we further examined the role of PLC β in pheromone transduction during different activity states. Therefore, the PLC-inhibitor U73122 and its non-functional analogue U73343 were passively perfused into the sensilla and the responses to brief pulses of bombykal (1 μ g BAL), the main pheromone component, were recorded. During the activity phase of the moth the sensillum potential (SP) amplitude as well as the action potential (AP) frequency in responses to short physiologically low BAL stimuli were significantly reduced with U73122. In the resting phase, however, inhibition of the PLC was less effective. Furthermore, the non-functional analogue as well as control recordings with DMSO did not affect the pheromone response at all times of the day tested. Our results strengthen the hypothesis that sensitive pheromone transduction in moths is regulated via the PLC β pathway. They are consistent with previous results which also confirmed the influence of DAG on the transduction of pheromone pulses (Gawalek et al., in prep.) Additionally, we could show that the PLC β -dependent, sensitive pheromone transduction is down-regulated during the resting phase while other, less sensitive transduction mechanisms still allow for pheromone responses at elevated threshold and compromised temporal resolution. We hypothesize that circadian changes in intracellular Ca²⁺ and cAMP-concentrations as well as odor stimulus properties determine which odor transduction mechanisms employing different second messenger-dependent ion channels are used in insect olfaction. [Supported by DFG grants STE531/19-1, STE531/20-1,2 and SPP 1392]

Mitochondrial Ca²⁺ mobilization plays a key role in mouse olfactory signaling

Lisa Marie Moeller, Daniela Fluegge^{1,5}, Annika Cichy¹, Monika Gorin¹, Agnes Weth², Sophie Veitinger¹, Silvia Cainarca³, Stefan Lohmer³, Sabrina Corazza³, Eva M. Neuhaus⁴, Werner Baumgartner², Jennifer Spehr¹, Marc Spehr¹

¹RWTH Aachen University, Institute for Biology II / Chemosensation, Worringer Weg 1, 52074 Aachen, Germany

²Department of Cellular Neurobionics, Institute for Biology II, RWTH Aachen University, Aachen, Germany

³Axxam SpA, Milan, Italy

⁴Charité - NeuroScience Research Center, Berlin, Germany

⁵These authors contributed equally to this work

In olfactory sensory neurons (OSNs), ionized calcium is a key component of a variety of sensory signaling pathways. Odorant receptor - ligand interaction elicits a primary receptor current by opening of cyclic nucleotide-gated (CNG) channels and Ca²⁺ influx into the cilia. This event triggers a number of secondary cellular responses that ultimately shape a neuron's electrical output signal. Therefore, cytosolic Ca²⁺ concentrations are tightly controlled.

Here, we investigate a functional role of mitochondria in shaping the odor-mediated Ca²⁺ response in OSNs. Using both genetically engineered mice that express a Ca²⁺-sensitive photoprotein associated to the inner mitochondrial membrane and a dedicated bioluminescence microscope, we establish a novel imaging approach to selectively record Ca²⁺ signals in OSN mitochondria at high temporal resolution. Electrophysiological recordings from identified single OSNs reveal the functional consequences of mitochondrial perturbation on both the odor-mediated primary receptor current and the sensory output signal. Combined with organelle mobility assays and ultrastructural analysis of individual OSNs, our study identifies mitochondria as key determinants of olfactory signaling.

We show that mitochondria play a vital role in olfactory Ca²⁺ signaling, controlling both primary and secondary Ca²⁺ pathways. When mitochondrial Ca²⁺ sequestration is pharmacologically impaired, the distinct time course of the odor-mediated cytosolic Ca²⁺ signal is significantly changed. Furthermore, our results suggest an activity-dependent mitochondrial translocation to dendritic compartments upon odor stimulation providing a context-dependent tool to maintain cytosolic Ca²⁺ concentration signaling integrity. Based on electrophysiological recordings, we suggest that Ca²⁺ mobilization by mitochondria exerts a regulatory function that ensures an individual neuron's broad dynamic response range and provides a mechanism of olfactory input-output gain control. Thus, OSNs function as simple stimulus detectors rather than intensity encoders, when mitochondrial function is impaired.

Profile of Ectopically Expressed Human Olfactory Receptors

Caroline Flegel, Stavros Manteniotis¹, Sandra Osthold¹, Guenter Gisselmann¹, Hanns Hatt¹

¹Ruhr-University Bochum, Department of Cell Physiology, Universitaetsstrasse 150, 44780 Bochum, Germany

Olfactory receptors (ORs) detect volatile odorant molecules from the environment. Initially, it was postulated that ORs are exclusively expressed in the olfactory epithelium. However, recent studies detected the ectopic expression of some ORs in a variety of other tissues (e.g. testes, prostate and gut). In the present study, we established a comprehensive expression analysis of ectopically expressed olfactory receptors in several tissues of the human body. Isolated RNA from different human tissues were analyzed by Illumina Next Generation Sequencing and compared to a panel of already existing sequencing data of various human tissues (Illumina Body Map project 2.0). These data show that human tissues express a large number of ORs which was verified by RT-PCR. We could observe the presence of ORs which were expressed in one particular type of tissue as well as ORs which presented a broader distribution. Further characterization of these ORs will provide new insights to the physiological role of distinct ORs outside the olfactory epithelium.

The insect olfactory system exploits stimulus-onset asynchrony for odor-background segregation

Paul Szyszka, Jacob S. Stierle¹, Stephanie Biergans¹, C. Giovanni Galizia¹

¹Universität Konstanz, Biologie, Universitätsstr. 10, 78457 Konstanz, Germany

Natural odors occur in a temporally-fluctuating, multi-odor background, yet insects possess a remarkable ability to extract intelligible odors under such complex conditions. The neural basis of odor-background segregations remains currently unknown. We addressed this issue by combining behavioral and physiological experiments in honeybees. We found 1) that honeybees can exploit short temporal asynchronies between odor stimulus-onsets to segregate odorants from different sources, and 2) that olfactory projection neurons are sensitive to stimulus-onset asynchronies of a few milliseconds. These data show that the insect olfactory system uses millisecond stimulus-onset asynchrony for odor-background segregation, similar to figure-ground segregation in the visual system and concurrent sound segregation in the auditory system of mammals.

Octopaminergic Neuromodulation in the Cockroach Antennal Lobe.

Cathleen Rotte, Malaika Fehlert¹, Peter Kloppenburg¹

¹Biocenter, Institute for Zoology, Center for Molecular Medicine (CMMC), and Cologne Excellence Cluster on Cellular Stress Responses in Aging-Associated Diseases (CECAD), University of Cologne, Germany

To optimize information gathering, sensory systems have evolved a variety of mechanisms that enable them to adapt to changes in environmental conditions. In invertebrate sensory systems, the biogenic amines octopamine (OA) and its precursor tyramine have been strongly implicated in such events. OA functions as a neurotransmitter, neurohormone, and neuromodulator in the insect nervous system and affects a variety of physiological processes. There is convincing evidence that OA also acts as an important neuromodulator in olfactory processing and learning in insects. In various insect species such as honeybee and cockroach, OA was found to be located in the antennal lobes (AL), the first relay for olfactory information processing. Here, a complex network of inhibitory and excitatory local interneurons interacts to restructure the olfactory representation in the AL, thereby regulating the tuning profile of projection neurons (PNs).

In this study we started to investigate the cellular actions of octopamine on identified AL neurons in an intact brain preparation. With current clamp recordings in the perforated patch clamp configuration we could show that OA increases the excitability or even induces spontaneous firing and bursting in synaptically isolated uniglomerular PNs by modulating hyperpolarization activated inward currents (I_h). A detailed analysis of the concentration-response relation and the blockage of OA induced cellular effects by the OA receptor blocker Epinastine are currently performed.

This work was supported by the DFG grant KL 762/5-1 to PK.

The expression patterns of odorant binding proteins and receptors indicate distinct subsets of olfactory sensilla on the antenna of *Anopheles gambiae*

Anna Schultze, Danuta Schymura¹, Jürgen Krieger¹

¹University of Hohenheim, Institute of Physiology, Garbenstr. 30, 70599 Stuttgart, Germany

Females of the malaria mosquito *Anopheles gambiae* rely on their olfactory system for finding a blood host, nectar sources or oviposition sites. The initial step in odorant detection on the antenna is the entry of odorants through cuticle pores of sensory hairs, called sensilla. Then odour molecules are supposed to be captured by odorant binding proteins (OBPs), which solubilize them in the aqueous sensillum lymph and transfer them to olfactory receptors (ORs) in the dendritic membrane of olfactory sensory neurons (OSN). Genes for about 60 putative OBPs and 79 candidate ORs have been identified in the genome of *A. gambiae*, suggesting that certain OBP-OR combinations are co-localized in antennal sensilla and interplay in odorant detection. While recent functional characterization of a number of OBPs and many ORs has indicated broad as well as more defined ligand spectra and identified first cases of "ligand-matched" OBP-OR pairs, little is known about their co-localisation in antennal sensilla.

We have assessed the sensilla localisation for a subset of OBPs and ORs, which were selected based on a predominant expression in female antenna or a proposed role in host-odour detection. Toward this goal we visualized the relative position of the OBP-expressing support cells and the OR-expressing OSNs by means of two-colour whole mount fluorescence *in situ* hybridization (WM-FISH) with combinations of differentially labeled riboprobes for two OBPs or OBP-OR pairs. We found that certain OBP-pairs were co-expressed by the same support cells, suggesting co-occurrence within the sensillum lymph of olfactory hairs. Furthermore, the data demonstrate a complex expression-mosaic of OBPs indicating different sensilla types with partially overlapping OBP equipment. For certain OBP-OR pairings we detected the OBP-expressing support cells in direct vicinity of the OR-expressing OSN, suggesting co-existence of the OR-OBP pair in the same sensillum. For a number of OR-OBP combinations this finding was validated by combining WM-FISH employing an OR-specific antisense RNA probe with whole mount fluorescent immunohistochemistry (WM-FIHC) using an OBP-specific antiserum. Moreover, WM-FISH/FIHC experiments allowed to clearly assign expression of distinct OBP-OR pairs to a distinct sensillum hair-type.

This work was supported by a grant from the European community's Seventh framework Programme project ENAROMaTIC (FP7/2007–2013; agreement FP7-222927).

Cloning and expression pattern of a GABAB-receptor subunit from the antennae of male *Heliothis virescens*

Pablo Pregitzer, Heinz Breer¹, Jürgen Krieger¹

University of Hohenheim, Institute of Physiology, Garbenstrasse 30, 70599 Stuttgart, Germany

The olfactory system of male moth is highly specialized for the detection of female-released sex pheromone blends. On the antennae pheromone-responsive olfactory sensory neurons (Ph-OSNs) are housed in often very long sensilla hairs (s. trichodea) and are endowed with specific pheromone receptors in their dendritic membrane. Moreover, Ph-OSN converge their axons into separate compartments of the macroglomerular complex (MGC), the pheromone-processing center within the antennal lobe (AL). Here Ph-OSNs synapse onto projection neurons (PNs), which transmit the pheromone information into higher brain centres. Recent work on the olfactory system of *Drosophila melanogaster* has provided evidence for a presynaptic gain control mechanism, which involves metabotropic GABAB receptors (GABAB-R) and allows for a fine tuning of synaptic transmission from olfactory sensory neurons onto PNs. Because male moths are exposed to a broad range of pheromone concentrations, which can be extremely low in far distance from the females but very high when approaching the signal source, a GABAB-R-mediated gain control mechanism at the level of Ph-OSN may be particularly important for setting the sensitivity and detections range of the pheromone recognition system. To approach the question if such a mechanism may be realized in moth attempts were made to identify a GABAB receptor from the tobacco budworm *H. virescens*. By using a combination of RT-PCR cloning and antennal cDNA library screening we identified a cDNA encoding a GABAB-R1 receptor protein. Moreover, based on the HvirGABAB-R1 sequence it was possible to predict a GABAB-R1 protein from genome sequences of the silkmoth *Bombyx mori*. To assess the expression of HvirGABAB-R1 in OSNs of male antenna we performed whole-mount in situ hybridization (WM-ISH) experiments. Under the long sensilla trichodea we visualized several HvirGABAB-R1 positive cells. A similar labeling pattern was obtained in experiments using a pheromone receptor specific probe. In addition, the HvirGABAB-R1 probe labelled several cells under shorter trichoid sensilla, but never stained cells under mechanosensory/gustatory sensilla chaetica. Together, the results indicate that a GABAB receptor is expressed in pheromone-responsive OSNs of *H. virescens* and suggest a presynaptic gain control mechanism.

This work was supported by the Deutsche Forschungsgemeinschaft SPP 1392.

Comprehensive RNA-Seq Expression Analysis of Sensory Neurons with Focus on Trigeminal Ganglia

Stavros Manteniots, Ramona Lehmann², Caroline Flegel¹, Benjamin Schreiner¹, Janine Altmüller³, Nicole Schöbel², Hanns Hatt¹, Guenter Gisselmann¹

¹Ruhr-University Bochum, Department of Cell Physiology, Universitätsstr. 83, 44780 Bochum, Germany

²Leibniz-Institut für Arbeitsforschung TU Dortmund, 44139 Dortmund, Germany

³Cologne Center for Genomics, Universitaet zu Koeln, 50931 Koeln, Germany

The specific function of sensory systems is often connected to tissue specific expression of genes which are coding for sensor proteins or are involved in membrane signaling. Using the Next Generation Sequencing method (RNA-Seq), we were able to analyze the whole transcriptome of the trigeminal ganglia (TG) and the dorsal root ganglia (DRG) of mice. The expression of 15445 genes in the TG and 15347 in the DRG had been detected. In order to analyze the global gene expression pattern of the peripheral neuronal tissues, a comparison of those to the tissues liver, brain, olfactory epithelium, skeletal muscle and testis have been carried out. The transcriptome data of TG and DRG have been scanned for all the in mice known 458 non-olfactory G-protein coupled receptors (GPCR) and for the most important 195 ion channels. Focusing on membrane proteins higher than 1 FPKM, 95 GPCRs and 32 ion channels which were previously not described as expressed in TG were detected and ranked with regard to their specific expression in TG. To validate the RNA-seq data, In Situ Hybridization experiments (ISH) were performed. Additionally, a comparison of the gene expression differences for the two homologous tissues TG and DRG was performed. In total, 646 genes in TG were detected which were not expressed in DRG and 548 genes could be identified in DRG but not in TG. With the present transcriptome data, a support of the current knowledge for all known and unknown channels and receptors expressed in TG could be achieved. To fully understand the role of trigeminal sensing and the physiological and pathophysiological mechanism of pain behavior, as in neuropathic pain, trigeminal neuralgia or migraine, it is necessary to examine the channel and receptor expression pattern of the TG.

Putative chemosensory cells at the “limiting ridge” and their interaction with “effector” cells

Julia Eberle, Patricia Widmayer¹, Heinz Breer¹

¹University of Hohenheim, Institute of Physiology, Garbenstraße 30, 70599 Stuttgart, Germany

It has been shown in previous studies that in the murine stomach many brush cells - putative chemosensory cells - are located underneath a tissue fold, called “limiting ridge” at the gastric entry as well as at the boundary between fundus and corpus mucosa. However, it is still unclear how these cells are arranged along the course of the tissue fold. This is mainly due to the fact that cross sections through the gastric mucosa usually represent only short segments of the “limiting ridge” and the underlying corpus mucosa. Therefore a technique was established to prepare tissue sections which allowed to analyse the corpus epithelial cells facing the “gastric groove” over a relatively long distance. Immunohistochemical staining of the sections visualized a high number of cells expressing cytokeratin 18, a marker for brush cells. The labeled cells located along the “gastric groove” bordering the corpus epithelium appeared to be arranged in a palisade - like fashion. There is evidence from previous studies indicating that some of these cells express gustducin, the alpha subunit of the trimeric G-protein which is involved in sweet, bitter and umami taste. Detailed analyses demonstrated for the first time that the majority of cells clustered along the distal wall of the “gastric groove” also express PLCB2 and TRPM5, two additional elements of the gustatory transduction cascade. Thus, the brush cells beneath the “limiting ridge” comprise the molecular equipment which may enable them to sense the chemical composition of the gastric luminal content. How the cells feed this information into the regulatory processes of the stomach is unclear. There is no indication that the putative chemosensory cells at the “limiting ridge” operate as endocrine cells, i.e. releasing signaling molecules into the blood circulation. However, in previous studies it has been found that endocrine cells (ghrelin, serotonin) were positioned in close vicinity to the sensory cells. Accordingly, it is conceivable that both cell types communicate via paracrine mechanisms. Furthermore it is possible that the brush cells also interact with afferent fibers of the enteric nervous system, since enteric nerve fibers interfuse the mucosal epithelium extensively, however they do not have direct contact to the lumen of the GI tract. Thus, the afferent nerve fibers rely on information from sensory cells with immediate contact to the lumen. Immunohistochemical stainings indicated that a dense network of NCAM positive fibers is located in close vicinity to the basolateral pole of brush cells underneath the “limiting ridge”. Thus, a paracrine interaction between the mucosal sensory cells and the nerve fibers seemed plausible. In line with prior observations on rats, we found that brush cells in the mouse stomach express nitric oxide synthase, suggesting that nitric oxide may operate as a gaseous transmitter between brush cells and adjacent “output” cells. In addition we have found that choline acetyltransferase (ChAT), the enzyme for synthesizing acetylcholine, is expressed in the clustered brush cells; ChAT expression was also demonstrated in so-called “solitary” chemosensory cells in various other tissues. The relevance of this finding was supported by co-staining experiments demonstrating that SNAP25, an important member of the SNARE complex, was expressed in all ChAT positive cells. The results point to an exocytotic release of acetylcholine from these putative chemosensory cells which could activate adjacent nerve fibers of the enteric nervous system. Thus, putative chemosensory brush cells located beneath the “limiting ridge” seem to have different options to convey the chemosensory input onto “effector cells”.

This work was supported by the Deutsche Forschungsgemeinschaft.

Electrophysiological investigation of intrinsic mitral cell properties in the mouse accessory olfactory bulb

Monika Gorin, Marc Spehr¹

¹RWTH Aachen, Institute for Biology II, Dept. of Chemosensation, Worringer Weg 1, 52074 Aachen, Germany

The accessory olfactory bulb (AOB) represents the first relay station of information processing in the rodent accessory olfactory system. AOB mitral/tufted cells, which are the main excitatory projection neurons in the AOB, receive synaptic input from sensory neurons in the vomeronasal organ. In turn, mitral cells are modulated by different classes of inhibitory neurons, such as granule and periglomerular cells.

Despite their physiological significance, the intrinsic properties of mitral cells and their role in social information coding and signal integration in the AOB are not fully understood. Here, we investigate the biophysical properties of AOB mitral cells. Using both voltage-clamp and current-clamp whole cell recordings from optically identified mitral cells in acute mouse AOB tissue slices, we show that a distinct population of AOB mitral cells display an unconventional intrinsic discharge pattern. Using pharmacology and classic channel biophysics, we analyze several ionic conductances underlying this characteristic output.

Ongoing research aims to fully characterize AOB mitral cell firing patterns to understand their role(s) in olfactory information coding and processing in the mammalian accessory olfactory system.

Benchmarking *Drosophila* receptor neurons for technical applications

Thomas Nowotny, Stephen Trowell², Marien de Bruyne³

¹University of Sussex, School of Engineering and Informatics, Falmer, BN1 9QJ Brighton, United Kingdom

²Food Futures Flagship, CSIRO Eco Systems Sciences, Canberra, ACT 2601, Australia

³Biological Sciences, Monash University, Clayton, VIC 3800, Australia

Animals detect volatiles in the environment with an animal-specific set of olfactory receptor molecules. The olfactory receptors (ORs) of the fruit fly *Drosophila melanogaster* form one of the best characterized sets of this kind. Recently, it has been suggested that, while the receptors have evolved to provide information about chemicals that are behaviorally relevant to the fly, they might also be used for technical applications [1]. Two examples of possible applications are detecting security threats [1] and detecting and judging the quality of wines [2]. *Drosophila* receptors do show noticeable responses to the relevant chemicals in both applications [1,2]. However, no systematic assessment has yet been performed of what type of problems *Drosophila* ORs are likely able to solve and which combination of ORs should be used to maximize the chances of success.

To address this problem we collected a large number of in vivo recordings from individual *Drosophila* olfactory receptor neurons (ORN) in response to two sets of chemicals: 36 chemicals related to wine making ("wine set") [2] and 35 chemicals related to security applications ("risk set") [1]. We characterized the responses of ORNs by their mean firing rate and the standard deviation of the mean in repeated experiments. Due to the difficult experimental procedure the number of samples per OR type varies significantly. We, therefore, resampled 20 responses per OR type and chemical from a Gaussian distribution with the experimentally observed mean and standard deviation. We then used these responses to classify the chemicals within the two sets all against all using a standard linear support vector machine classifier [3]. To address the question of selecting the best combination of sensors we used a so-called wrapper approach: We formed all possible combinations of subsets of receptors and evaluated their performance in odor recognition in 10-fold cross-validation.

We find that, in contrast to concurrent work with metal oxide sensors (Nowotny T, Berna A, Trowell S: in review), *Drosophila* receptors achieve the best recognition accuracy in both applications (81.5% for the wine set and 77.6% for the risk set) if the outputs of all 20 OR types are used. However, a level of 90% of this performance (73.4% and 69.8% respectively) can already be achieved by an appropriately chosen subset of only 10-11 receptors (The chance levels for the performance are 2.8% and 2.9% respectively). The sets of most relevant receptors for both applications have considerable overlap but are not identical. Interestingly, if only very few receptor types are utilized, *Drosophila* ORs distinguish the risk set chemicals significantly better than those of the arguably behaviorally more relevant wine set. If all 20 receptor types are included, however, the situation is reversed and the wine set is classified better.

Our computational analysis reveals that *Drosophila* receptors appear surprisingly capable to distinguish chemicals that they have not been evolved to process, making their use in technical applications a realistic possibility.

Acknowledgements

TN was partially financed by a Distinguished Visiting Scientist award of CSIRO.

References

1. Marshall B, Warr CG, de Bruyne M (2010) Chem Senses 35(7):613-625.
2. De Bruyne M, Berna AZ, Trowell SC (2010) Proc. 14th Australian Wine Industry Technical Conference, p321.
3. Chang C-C, Lin C-J. ACM Trans Intell Syst Tech 2011, 2:1-27.

Function of adult-generated dopaminergic interneurons in the olfactory bulb glomerular layer

Wolfgang Georg Bywalez, Michael Mörschel¹, Philipp Serr¹, Jovica Ninkovic²,
Magdalena Götz², Veronica Egger¹

¹LMU München, Neurobiology, Department II of Biology, AG Egger, Großhaderner Str. 2, 82152 Planegg-Martinsried, Germany

²Helmholtz Center, Neuherberg, Germany

Adult-born interneurons play an important role in remodeling circuits in the mammalian olfactory bulb (OB). Subsets of both glomerular neurons (GNs) and granule cells experience a life-long turnover. The GN population is classified into several subtypes based mainly on neurochemical markers and morphology, yet the specific functional impact of the respective subtypes is barely known. The dopaminergic (DA) subtype of GNs constitutes a substantial fraction of adult-born interneurons. DA GNs appear to profoundly influence odor processing via complex synaptic arrangements that involve direct reciprocal interaction of their dendrites with olfactory nerve (ON) input but also intraglomerular dendrodendritic feedback loops with tufted and mitral cell (MC) apical dendrite tufts.

To investigate the properties of these neurons, we use a mutant that expresses GFP in adult-born DA neurons upon tamoxifen induction (DAT::Cre^{ERT2}). We image dendritic Ca²⁺ transients using two-photon microscopy of patch-clamped GFP+ cells in acute brain slices of adult mice. So far, we have observed two subtypes of adult-born DA PGNs with distinct morphological and physiological properties. The first subtype is characterized by dense dendritic ramifications (“tuftlets”) within a glomerular subcompartment. The dendritic Ca²⁺ responses to somatic action potentials (AP) slightly increase with distance from the cell body and are significantly higher within the tuftlets ($n = 55$ locations in tuftlets, $(\Delta F/F)_{AP} = 18 \pm 8\%$ vs. $n = 16$ non-tuftlet locations, $(\Delta F/F)_{AP} = 13 \pm 7\%$; $p < 0.05$), consistent with the fact that those neurons conduct their output in part via dendrodendritic synapses. The “tuftlet” neurons show continuous spiking upon step depolarizations. The second subtype shows a simpler dendritic morphology and significantly smaller Ca²⁺ transients ($n=13$ locations, $(\Delta F/F)_{AP} = 10 \pm 8\%$, $p < 0.002$ vs. all tuftlet cell locations). Upon step depolarizations these neurons spike only once. Whether they actually constitute a distinct class of DA GNs or merely an earlier developmental state of the first subtype remains to be resolved.

The functional impact of this cell type on the OB network level can be experimentally tested in Pax6^{14Neu} mutants with genetically reduced numbers of DA GNs. We observed Ca²⁺ responses in populations of MCs labeled via the bolus loading technique in acute slices following ON stimulation that was modeled on in vivo activity patterns. In both WT and mutants, we observed two general types of MC Ca²⁺ responses to single ON stimulation pulses (in $n = 83$ MCs). A third of all MCs shows a simple low amplitude $\Delta F/F$ response, whereas the remaining MCs show a larger saturating response, that is usually as large as subsequently recorded responses to ON train stimulation. Single MC whole cell recordings under the same conditions in WT reveal corresponding response types, single APs and bursts that are correlated to the occurrence of a long-lasting depolarization ($n = 5$ vs. $n = 6$ MCs). This extended mitral cell firing could in turn activate release of DA. Regarding the network properties, preliminary data show that the latency of MC firing upon ON stimulation is probably shorter in mutant mice (8 ± 17 ms, $n= 24$ cells from 2 mutant animals vs. 66 ± 46 ms, $n= 83$ cells, from 10 WT animals), possibly due to the reduced level of glomerular inhibition.

Thus we have by now established paradigms to further examine the specific contribution of DA GNs to olfactory processing.

Dominance of weaker ligands in a complex odor mixture

Daniel Münch, Benjamin Schmeichel¹, Ana F. Silbering², C. Giovanni Galizia¹

¹Neurobiology, University of Konstanz, D - 78457 Konstanz, Germany

²Center for Integrative Genomics, University of Lausanne, CH - 1015 Lausanne, Switzerland

Natural occurring odors are not mono-molecular but appear as mixtures of tens or even hundreds of components, all in different concentrations. When such mixtures reach for example the antenna of a fruit fly, many of the differentially but overlapping tuned types of olfactory receptor neurons (ORNs) will be activated. But a single ORN is likely being activated by more than one of the components the mixture contains. What does the response of a single type of ORN to such a mixture look like? What kind of mixture interaction, if any, is present at the ORNs? Straight-forward hypotheses might include that the component at highest concentration, or the best ligand in a mixture dominate the response, two hypotheses that we tested. Furthermore, what is the contribution of minor components?

To address these questions we performed Ca^{2+} imaging on the antenna of *Drosophila melanogaster* in response to an artificial banana-like mixture and its isolated components. We created this mixture by using 15 components from the published aromatic profile of banana fruit. The imaging was performed on neurons bearing an olfactory receptor that is known to be strongly activated by banana scent, dOr22a.

We found that five out of the 15 components elicited a significant response when presented alone at their natural banana concentration. The response elicited by one of these components alone (isopentyl acetate) was not different from the response the full mixture elicited. Thus for dOr22a the single component isopentyl acetate is equivalent to the full bouquet. As adding other effective components did not alter the response, this indicates that hypoadditive mixture interactions are taking place. Isopentyl acetate turned out to be the main response driving force, but was neither the highest concentrated component, nor the best ligand for dOR22a in the mixture, disproving both "straight-forward" hypotheses put forward above.

To analyze the underlying mechanisms of these interactions we created binary mixtures and recorded full dose-response curves. From this data we modeled responses for different mixture interaction scenarios. These models confirm hypoadditivity and show that this effect likely arises from syntopic interactions at a single binding site on dOr22a. While we cannot exclude intracellular interactions or another binding site, these are not necessary to explain the effects we found. In addition syntopic interaction is ideally suited to ensure a stable response across a range of mixture concentration.

Modulation of pheromone responses in antennal trichoid sensilla of the hawkmoth *Manduca sexta* by Orco agonism and antagonism

Andreas Nolte, Nico Funk¹, Latha Mukunda², Petra Gawalek¹, Sarah Körte², Dieter Wicher², Bill S. Hansson², Monika Stengl¹

¹University of Kassel, Animal Physiology, Heinrich-Plett-Straße 40, 34132 Kassel, Germany ²Max Planck Institute for Chemical Ecology, Evolutionary Neuroethology, 07745 Jena, Germany

Females of the hawkmoth *Manduca sexta* attract their conspecific males via pulsatile release of species-specific pheromones. Males detect the pheromones with long trichoid sensilla on their antennae. Two olfactory receptor neurons (ORNs) innervate every trichoid sensillum, one of each is sensitive to the main pheromone component bombykal (BAL). Insect olfactory transduction is still under debate. Work in the fruitfly suggested that olfactory receptor-coreceptor (OR/Orco) heteromers form ligand-gated ion channels without or with involvement of a G_s-dependent signal cascade. Other data suggest that in different insect species PLC β -dependent odor transduction cascades are employed without the need for ionotropic odor transduction cascades.

With the Orco agonist VUAA1 and with possible antagonists HMA and MIA the role of Orco in hawkmoth pheromone transduction was examined. With calcium imaging experiments on HEK 293 cells heterologously expressing MsexOrco an Orco-dependent increase in spontaneous activity was observed as well as VUAA1-dependent influx of calcium via Orco. Coexpression of MsexSNMP-1 and one of the male-specific olfactory receptors MsexOR-1 or MsexOR-4 increased the VUAA1 response amplitude. Then, the Orco agonist and antagonists were applied in single sensillum recordings of BAL-stimulated ORNs at the end of the activity phase at Zeitgeberzeit (ZT) 1-3 and the resting phase (ZT 9-11) with a non-adapting BAL stimulus protocol. Additionally, the spontaneous activity without BAL stimulation was analyzed. While VUAA1 application (100 μ M) did not affect the BAL-dependent sensillum potential amplitude (SPA), the frequency of the first 5 APs of BAL responses was reduced. In contrast, VUAA1 significantly increased the background activity and also the spontaneous activity at both ZTs. Thus, no evidence was found for Orco-dependent ionotropic pheromone transduction. Instead, Orco mediates spontaneous activity. Hence, it was hypothesized that Orco forms a hormone-gated pacemaker channel which controls kinetics and sensitivity of the ORNs. In accordance with these results the prospective Orco antagonists MIA and HMA (10 μ M) both reduced the background activity between BAL stimuli. In addition, the BAL-dependent SPA and the AP frequency decreased.

In current experiments it is investigated whether MIA and HMA are specific Orco antagonist or whether they affect other second messenger-dependent ion channels in hawkmoth ORNs.

[Supported by DFG grant STE 531/20-1 to MS and the Max Planck Society.]

Role of the Global Lateral Inhibition in the Olfactory Bulb Network and Discrimination Time in Mice

Daniel Nunes, Thomas Kuner²

^{1,2}PDBEB, Center for Neuroscience of Coimbra, Coimbra, Portugal; ²Functional Neuroanatomy, INF 307, Heidelberg, Germany

Granule cells (GC) of the olfactory bulb can operate different modes of inhibition: recurrent inhibition, local lateral inhibition and global lateral inhibition (GLI). The latter employs Na channel-driven action potentials to release GABA from all gemmules thereby inhibiting all connected mitral cells (MC). The role of GLI in olfactory bulb network function and odor discrimination behavior is unknown.

We first determined the identity and distribution of voltage-gated Na channel α -subunits in identified GCs using 3D-Immunohistochemistry (Dondzilo et al., 2010). We found that mature GCs exclusively express the NaV1.2 α -subunit. Channels formed clusters at the cell body, dendrites and at the neck of the gemmules. To selectively abolish GLI in GCs, we expressed an shRNA directed against the NaV1.2 α -subunit by stereotaxically delivering AAV1/2-shRNA into the olfactory bulb (Abraham et al., 2010). The effectiveness of shRNA-mediated downregulation of NaV1.2 α -subunit expression was tested in acute brain slices of the olfactory bulb. Out of four shRNAs targeting different areas of the Na channel mRNA, two abolished the Na⁺ current almost entirely while two showed a 50% reduction compared with non-infected GCs. The consequences of this perturbation on odor discrimination accuracy, discrimination time to stimulus similarity and concentration were then evaluated using the go/no-go operant conditioning paradigm (Abraham et al., 2004). Preliminary results indicate that both discrimination accuracy and time were decreased when mice discriminated binary odor mixtures at concentrations close to detection threshold. These results suggest a specific role for GLI in discriminating highly similar mixtures at detection threshold.

Functional properties of oligomeric constructs of the *Drosophila* odorant co-receptor Orco

Latha Mukunda , Vardanush Sargsyan¹, Sofia Lavista-Llanos¹, Bill S. Hansson¹, Dieter Wicher¹

¹Max Planck Institute for Chemical Ecology, Department of Evolutionary Neuroethology, Hans-Knöll-Strasse 8 , 07745 Jena, Germany

Insect odorant receptors (ORs) are ligand gated ion channels formed by heterodimeric complexes of a ligand binding olfactory receptor protein (ORX) and a highly conserved odorant co-receptor (Orco). Heterologously expressed insect ORs produce a fast ionotropic current and a slow metabotropic current. Moreover, Orco alone forms a functional ion channel in the absence of ligand-selective ORs. Previous single channel recordings in heterologously expressed Orco proteins showed synchronized activity of multiple Orco proteins upon cAMP stimulation. We hypothesize that cAMP promotes synchronization by oligomerization. To test the functional effect of Orco oligomerization we engineered Orco dimers, the simplest oligomeric Orco construct. Two Orco proteins were coupled via an 1-transmembrane protein to grant for proper orientation of both parts. We performed calcium imaging and patch clamp experiments on both Orco monomers and Orco dimers which were stably expressed in CHO (Chinese Hamster Ovary) cells. Calcium imaging experiments demonstrate that the Orco dimer constructs forms calcium conducting ion channels. Single channel recordings of excised outside-out patches show that VUAA1, an allosteric agonist of Orco, activates both Orco monomers and dimers with distinct single channel properties.

This study was supported by the Max Planck Society.

Mammalian specific OR37 receptors are differentially activated by distinct odorous fatty aldehydes

Verena Bautze, Wolfgang Schwack², Heinz Breer¹, Jörg Strotmann¹

¹Institute of Physiology, University of Hohenheim, Garbenstr. 30, 70593 Stuttgart, Germany

²Institute of Food Chemistry, University of Hohenheim, Garbenstr. 28, 70593 Stuttgart, Germany

The capacity of the mammalian olfactory system to detect an enormous array of different chemical compounds is based on a large repertoire of odorant receptors (ORs). A small group of these ORs, the OR37 subfamily, is unique due to a variety of special features. Members of the OR37 family are exclusively found in mammals, they share a high degree of sequence homology and are highly conserved during evolution. In order to identify ligands for these atypical receptors we exposed mice to odorant compounds and monitored the activation of OR37 glomeruli through the expression of the activity marker *c-fos* in juxtglomerular cells. Stimulation with long-chain fatty aldehydes elicited strong activation of OR37A, B or OR37C glomeruli; each of them responding preferentially to an aldehyde with different chain length. To identify the source for these compounds the living-environment of mice was analysed. Gas chromatography and mass spectrometry identified distinct ligands in headspace probes. Using these stimuli, defined OR37 glomeruli could be activated. These results indicate that ligands for OR37 receptors are present in the social environment of mice.

Circadian oscillations of cyclic nucleotide concentrations in insect antennae

Thomas Schendzielorz, Katja Schirmer¹, Julia Schulze¹, Monika Stengl¹

¹University of Kassel, Animal Physiology, Heinrich-Plett-Str. 40, 34132 Kassel, Germany

Pheromone-dependent mating activity is under circadian control in different holo- and hemimetabolous insects. Correlating with behavioral rhythms, also circadian rhythms in antennal sensitivity were observed, but underlying mechanisms remain unresolved. Interestingly, in moths' olfactory receptor neurons adapting pheromone concentrations elevate cGMP levels, which appear to decrease pheromone sensitivity. In contrast, cAMP elevations sensitized pheromone responses, partly mimicking effects of the stress hormone octopamine (OA).

To determine, whether endogenous rhythms in cyclic nucleotide levels underlie circadian rhythms in olfactory sensitivity enzyme-linked immunosorbent assays were performed at different times of the day in light dark cycles and under constant darkness (DD). Baseline concentrations of cAMP and cGMP were measured in antennal lysates of the hemimetabolous cockroach *Rhyparobia (Leucophaea) maderae* as well as the holometabolous hawkmoth *Manduca sexta*. It was shown for the first time that cAMP- and cGMP baseline levels oscillate in anti-phase in a Zeitgeber-time-dependent manner in insect antennae with the maximum in cAMP-concentrations coinciding with maximal mating activity. Moreover, the cAMP baseline oscillation persisted in cockroach antenna under DD, whereas the cGMP baseline level decreased progressively. Since circadian rhythms in the stress hormone OA were described in the hemolymph of the hawkmoth, next, it was investigated whether OA elevates antennal cAMP levels. Indeed, OA activated antennal adenylyl cyclase activity in both species. Therefore, this study provides first evidence for antagonistic rhythms of cyclic nucleotides modulating odour sensitivity in insect antennae to orchestrate pheromone-dependent behaviour under circadian and hormonal control. [Supported by DFG grant STE531/20-1 to MS].

Characterization and Role of Ca^{2+} - Dependent Outward Potassium Currents in Uniglomerular Projection Neurons of the Antennal Lobe of *Periplaneta americana*.

Sabine Schleicher, Cathleen Rotte¹, Ben Warren¹, Andreas Klein¹, Viktor Bardos¹,
Peter Kloppenburg¹

¹University of Cologne, Institute for Zoology, Zùlpicher Straße 47b, 50674 Cologne, Germany

In insects odors are detected by antennal sensory neurons and are initially processed in the first synaptic relay, the antennal lobe (AL), which is the functional equivalent of the mammalian olfactory bulb. The integrated olfactory information is conveyed from the AL to secondary centers in the protocerebrum by projection neurons (PNs), the analog of the mammalian mitral/tufted cells. The most prominent and most studied group of PNs are the uniglomerular projection neurons (uPNs), whose morphology and response properties are well described in various insect species. Typically, each uPN receives synaptic input in a single AL glomerulus from olfactory sensory neurons and local interneurons. Each uPN send an axonal projection terminating with boutons into the mushroom body calyx and/or the lateral lobe of the protocerebrum. uPNs are considered the only cholinergic input to the mushroom body calyx.

Since the electrophysiological properties including excitability, action potential waveform and firing pattern are at least in part determined by cell type specific ion channel expression, our long term aim is to analyze the distinct sets of ionic currents of the different AL cell types. Using whole cell patch clamp recordings we studied calcium activated potassium outward currents ($I_{\text{K}(\text{Ca})}$) of uPNs in an intact brain preparation of the cockroach *Periplaneta americana*. $I_{\text{K}(\text{Ca})}$ was dependent of both membrane potential and intracellular calcium concentration. Complete blockade of $I_{\text{K}(\text{Ca})}$ was achieved with charybdotoxin ($\text{IC}_{50} = 2.4\text{nM}$), whereas iberiotoxin blocked only 63% of $I_{\text{K}(\text{Ca})}$ even at the highest concentration tested (100nM). The functional role of $I_{\text{K}(\text{Ca})}$ was studied in current clamp recordings by occlusion experiments, in which $I_{\text{K}(\text{Ca})}$ was partially blocked. $I_{\text{K}(\text{Ca})}$ contributed to action potential repolarization and afterhyperpolarization. Blocking $I_{\text{K}(\text{Ca})}$ resulted in an increased firing frequency and reduced the latency to the first action potential during depolarization.

This work was supported by the DFG grant KL762/5-1.

Sugar-elicited search behavior: the blowfly's dance in honey bees

Axel Brockmann, Andrew Magis², Jake Herman³, Jonathan Massy³, Gene E. Robinson^{3,4}

¹National Centre for Biological Sciences, Tata Institute for Fundamental Research, Neurobiology and Behavior, GKVK Campus, Bellary Road, 560065 Bangalore, India;

² Center for Biophysics and Computational Biology, University of Illinois at Urbana Champaign, USA;

³ Department of Entomology, University of Illinois at Urbana Champaign, USA;

^{3,4} Institute for Genomic Biology, Neuroscience Program, University of Illinois at Urbana Champaign, USA.

One of the major questions in contemporary behavioral neuroscience is how social behaviors evolved from solitary behaviors. More than sixty years ago, Vincent Dethier suggested that the relatively simple sugar-elicited search behavior of blowflies might represent a locomotor pattern or behavioral module that was co-opted for the evolution of honey dance communication [1]. Both, the fly's "dance" and honey bee dance communication involve a characteristic turning behavior that is modulated by the value (sugar concentration) of a food reward. The Dethier hypothesis would predict that honey bees also show sugar-elicited search behavior, and use the same sensory motor system in dance behavior but this has never been tested. We started to test this prediction with a newly developed laboratory assay and observed that foragers do initiate a search behavior after ingesting a small amount of sucrose solution. Intriguingly, so do nurses and drones, which do not leave the hive to search for food, but feed or are fed from colony food stores. Similar to blowflies, the intensity of sugar-elicited turning behavior was dependent on hunger state and sucrose concentration. We also detected differences in search behavior between nectar and pollen foragers and between foragers either arriving or departing from a feeder. These results provide preliminary support for the Dethier hypothesis and also suggest mechanistic commonalities and differences between sugar-elicited search behavior and sugar-elicited dance behavior in honey bees. We also are using this assay to search for neurochemicals that modulate dance behavior. We are testing octopamine, which has previously been shown to modulate the probability of initiating dance behavior after foraging, and the neuropeptide tachykinin-related-peptide 3, which helps regulate walking in *Drosophila melanogaster* [2] and shows differences in brain abundances between nectar and pollen foragers as well as between dancing and non-dancing foragers [3,4]. Analysis of sugar-elicited search behavior has the potential to be a fruitful paradigm to study neural and molecular underpinnings of dance behavior and the evolution and plasticity of social foraging in bees.

References:

- [1] Dethier VG. 1957. Communication by Insects: Physiology of Dancing. *Science* 125, 331–336.
- [2] Kahsai L, Martin J-R, Winther AME. 2010. Neuropeptides in the *Drosophila* central complex in modulation of locomotor behavior. *JEB* 213, 2256–2265.
- [3] Brockmann A, Annangudi, SP, Richmond TA, Ament SA, Xie F, Southey B, Rodriguez-Zas SR., Robinson GE, Sweedler JV. 2009. Quantitative peptidomics reveal brain peptide signatures of behavior. *PNAS* 106, 2383–2388.
- [4] Brockmann A, Xie F, Sen Sarma, M, Kreher SA, Annangudi SP, Southey BR, Robinson GE, Sweedler JV. (in prep.) Identifying candidate neuropeptides involved in honey bee dance behavior using quantitative peptidomics.

Citral selectively inhibits human K_{2P}3.1 channels

Leopoldo Raul Beltran

¹Ruhr-Universität Bochum, Zellphysiologie, Universitätsstr. 150, 44801 Bochum, Germany

Citral (3,7-dimethyl-2,6-octadienal) is composed of the double bond trans (geranial, citral A) and cis (neral, citral B) isomers. It is a major component and the active ingredient of lemongrass oil, lemon peel, citronella, and palmarosa grass. We investigated the effect of citral and several other compounds used in perfumes or for culinary purposes on members of the TASK subfamily of human two-pore domain K⁺ (KCNK, K2P) channels. These channels participate in the leak or background potassium conductance in many types of excitable cells. They oppose membrane depolarization and cell excitability. These channels have been also reported to be modulated by several physical and chemical stimuli, especially by extracts from Szechuan pepper that induce a tingling sensation. We injected *Xenopus laevis* oocytes with cRNA coding for either hK2P9.1 and hK2P3.1, and we additionally generated point mutants by means of the overlap extension PCR technique. We evaluated the response of these oocytes to the above mentioned substances (many of which were TRP agonists) by means of the two-electrode voltage clamp technique. Although several of the substances under evaluation altered the basal activity of both channels in more than a 30%, only citral showed selectivity for hK2P3.1 channels. The dose-response curve showed an IC₅₀ value of $450.7 \pm 67.4 \mu\text{M}$, which is within the reported range of this substance on TRP channels. Our results have expanded the relatively scarce pharmacology of human K2P channels, providing now a new and selective blocker as well as several chemically related non-selective blockers. Additionally we have provided another target for Citral.

Neurochemical profiles of identified local interneurons in the antennal lobe of *Periplaneta americana*

Debora Fusca, Andreas Husch¹, Joachim Schachtner², Arnd Baumann³, Peter Kloppenburg¹

¹Biocenter, Institute for Zoology, Center for Molecular Medicine Cologne (CMMC), and Cologne Excellence Cluster on Cellular Stress Responses in Aging-Associated Diseases (CECAD), University of Cologne, Zùlpicher Str 47b, 50674 Cologne, Germany

²Animal Physiology, University of Marburg, Karl-von-Frisch Str. 8, 35043 Marburg, Germany

³Research Center Jùlich, Institute of Complex Systems, Cellular Biophysics (ICS-4), 52425 Jùlich, Germany

Processing of odor information involves neuronal interactions among the glomeruli in the insect antennal lobe (AL). These interactions are mediated by a complex network of inhibitory and excitatory local interneurons (LNs), which structures the olfactory representation and ultimately determines the tuning profile of projection neurons. LNs have distinct morphological and intrinsic electrophysiological properties and in addition to GABA and acetylcholine LNs may contain and release biogenic amines and various peptides that can potentially act as neurotransmitters or neuromodulators. In *Periplaneta americana* two main LN types are known: 1) Spiking type I LNs (LN I), that generate Na⁺ driven action potentials upon odor stimulation and exhibit GABA-like immunoreactivity (GABA-LIR) and 2) non-spiking type II LNs, subdivided by their morphological and physiological features into type IIa and type IIb, with unknown transmitter, that do not generate Na⁺ driven action potentials. The LN diversity implies that these neurons serve distinct functions in the olfactory system. Currently, the morphologically and physiologically distinct LN sub-types are not very well matched with the variety of potential neurotransmitters and -modulators. This, however, is an important prerequisite for a detailed understanding of the role of LNs in the olfactory circuit.

Our goal is to build up a comprehensive data set of individual identified LNs. Accordingly; we started to unequivocally assign potentially neuroactive substances to the functionally distinct LN sub-types by combining several single neuron techniques that include patch-clamp recording, single cell labeling and immunocytochemical methods.

Using an antibody against the biosynthetic enzyme choline acetyltransferase (ChAT) as a marker for cholinergic neurons, a subset of non-spiking LN IIa with distinct physiological and morphological properties was identified as cholinergic. In these type IIa1 LNs (LN IIa1), odor stimulation evoked depolarizations that generated Ca²⁺ driven 'spikelets', but not Na⁺ driven action potentials.

Furthermore, the neuropeptide allatotropin (AT) was assigned to spiking LN I and tachykinin-related peptides (TKRPs) were assigned to both LN I and non-spiking LN IIa1. This suggests, that AT is co-released with GABA in LN I, while TKRPs are co-released with GABA in LN I as well as with acetylcholine in LN IIa1.

This work was supported by the DFG grant KL 762/6-1 to PK.

Functional characterization of human trace amine-associated receptors (TAARs) in recombinant systems.

Ivonne Wallrabenstein, Jonas Kuklan¹, Lea Weber¹, Sandra Zborala¹, Markus Werner¹, Janine Altmüller³, Christian Becker³, Anna Schmidt², Hanns Hatt¹, Thomas Hummel², Günter Gisselmann¹

¹Ruhr University Bochum, Cellphysiology, Universitätsstrasse 150, 44780 Bochum, Germany

²Smell & Taste Clinic, Department of Otorhinolaryngology, University of Dresden Medical School ("Technische Universität Dresden"), Dresden, Germany

³Cologne Center for Genomics (CCG), University of Cologne, 50931 Cologne, Germany

Trace amine-associated receptors (TAARs) were defined as olfactory receptors in the olfactory epithelium of vertebrates. In rodents, TAAR expressing olfactory sensory neurons project to specific glomeruli in the dorsal bulb and constitute an olfactory subsystem that mediates high sensitivity detection of volatile amines. Some of these volatile amines are key odors of social cues that may elicit innate behaviours or physiological responses. In contrast to the well deorphanized rodent TAARs, agonists for the putative human olfactory TAARs 2, 5, 6, 8 and 9 have not been determined so far and the physiological relevance still remains elusive. We present a first successful functional expression of human TAARs and a highly specific agonist of human TAAR5, the TAAR gene with the highest expression level in the human olfactory epithelium. We performed a ligand-screening and measured receptor activity using two different recombinant systems. Besides, we demonstrated that the ability to smell Trimethylamine, the potent TAAR5 agonist, is not correlated with a genetic polymorphism within one of the functional human TAAR gene reading frames.

Role of $G_{\alpha o/i}$ subgroup of G proteins in olfactory signaling of *Drosophila melanogaster*

Jennifer Sinthiya Ignatious Raja, C. Giovanni Galizia¹, Vladimir L Katanaev²

¹University of Konstanz, Department of Biology, Universitätsstraße 10, 78457 Konstanz, Germany

²Department of Pharmacology and Toxicology, University of Lausanne, CH-1015 Lausanne, Switzerland

Olfactory signal transduction in vertebrates and nematodes acts via G proteins. However, it still remains controversial whether this is also the case in insects. We investigated the role of the $G_{\alpha o/i}$ subunit of the G proteins in the olfactory signal transduction cascade for two olfactory receptors in *Drosophila melanogaster* by combining *in vivo* and *in vitro* methods. *In vivo* calcium imaging of flies with reduced $G_{\alpha o}$ activity (by expression of PTX; inhibits only $G_{\alpha o}$ in *Drosophila*) or downregulation of $G_{\alpha i}$ expression (by expressing siRNA specific to $G_{\alpha i}$ subunit) in olfactory receptor neurons expressing Or22a showed olfactory deficits in these cells. Mutant female flies exhibited lower response strength regardless of odor identity and intensity than the control flies. Also male flies showed similar effects like females, but the effects were not statistically significant for all the concentrations of the odorants tested. *Drosophila* ORs (Or22a & Or83b) were transiently expressed in human embryonic kidney cells (HEK293) to study the role of $G_{\alpha o/i}$ in detail. Stimulation with odorants elicited intracellular calcium increase in about 39% of cells, which is about 73% of transfected cells. Removal of external calcium completely abolished the response, indicating that calcium influx was generated by extracellular calcium. However, since CICR (calcium induced calcium release) inhibitors reduced the response, this calcium influx appears to be amplified by CICR channels. Incubation with the $G_{\alpha o/i}$ inhibitor Pertussis Toxin (PTX) greatly reduced the response. Further analysis showed that this effect was mediated by $G_{\alpha i2}$. In contrast, $G_{\alpha o}$ subunit suppressed the response, possibly sequestering the $G_{\beta\gamma}$ -subunits and arguing for a role of the $G_{\beta\gamma}$ heterodimer in signal propagation in this system. In conclusion, our results suggest a role for $G_{\alpha o/i}$ in olfactory signaling of *Drosophila melanogaster*. Given the evolutionary relatedness of insect olfactory receptors, we expect these results to extend to insects in general.

Deep Sequencing of the Murine Olfactory Transcriptome

Ninthujah Kanageswaran, Marilen Demond², Benjamin Schreiner¹, Janine Altmüller³,
Hanns Hatt¹, Günter Gisselmann¹

¹Ruhr-University Bochum, Department of Cell Physiology, Universitätstr., 44780 Bochum, Germany

²University of Duisburg-Essen, Department of Molecular Biology, 45122 Essen, Germany

³University of Koeln, Cologne Center for Genomics, 50931 Koeln, Germany

The sense of smell is one of the most versatile in terms of the multitude of different chemical substances that can be detected. Olfactory receptors (OR), discovered by Linda Buck and Axel Richard in 1991, constitute the largest superfamily of mammalian G-protein coupled receptors thereby accounting for the vast discriminatory power of the olfactory system. Based on a transduction concept and biochemical signal amplification via a complex network of intracellular effector proteins, ORs provide the molecular foundation for the detection of volatile odorant molecules from the environment. In humans, this is basically achieved by a relative small number of about 400 functional odorant receptors whereas rodents possess with about 1,200 a considerably higher number of OR genes.

The recent dramatic technical developments of the next generation sequencing techniques encouraged us to apply this technique for a murine transcriptome analysis of the olfactory epithelium (OE). Isolated RNAs from murine tissues were sequenced with the Illumina Genome Analyzer II to create a comprehensive expression analysis. In our work, we detected the expression of more than 1,000 OR genes. Additionally, we confirmed the strong expression of genes participating in olfactory signal transduction and moreover also identified a range of new potential players in olfaction. The molecular portrait of the OE revealed by this analysis uncovers new and valuable approaches, which will be beneficial to gain additional insights into molecular mechanisms underlying olfaction.

Long-term effects of noradrenaline on olfactory sensory neuron input to the main olfactory bulb.

Dennis Eckmeier, Stephen D Shea¹

¹Cold Spring Harbor Laboratory, Shea lab, 1 Bungtown Road, 11724 Cold Spring Harbor, New York, USA

Many mammals discriminate individual conspecifics by their smell. In mice and several other species, certain forms of social memory are associated with plasticity in the main olfactory bulb (MOB). During social encounters, the neuromodulator noradrenaline (NA) is released from the brain stem nucleus locus coeruleus (LC), and the resulting elevated concentration of NA in the MOB is believed to trigger long-term plasticity. We showed previously that we can induce social memories in anesthetized mice by pairing activation of LC with conspecific urine from unfamiliar mice. In a subsequent behavioral test, mice treated the 'paired urine' as if it were a familiar stimulus (exhibiting reduced interest) while they treated the 'unpaired urine' as if it were a novel stimulus. We further found that the response of mitral/tufted cells (M/T) which project out of the MOB, exhibited reduced activation by the learned odor. The same effect was observed for arbitrary odors. We are currently examining how NA-dependent memories are stored among populations of glomeruli, and whether the storage mechanisms involve regulation of presynaptic and/or postsynaptic activity in the glomeruli. Our approach is to measure odor-driven activity in populations of glomeruli on the dorsal surface of the MOB with widefield optical imaging. Initial data were collected from intrinsic optical signals. We presented several odors before, during and after pairing 30 presentations of one odor with a 20 s, 5Hz, 40 μ A electrical stimulus train to LC. The population response as it is reflected by intrinsic optical signals (n=127 glomeruli; 9 animals) significantly shifted after LC stimulation, while sham controls (n=88 glomeruli; 4 animals) exhibited no change. Most (73.23%) glomeruli showed response suppression (n=93, median 62% suppression), however, many (21.26%) glomeruli increased the strength of their response (n=27, median 125% increase). This raises the possibility that the observed glomerular changes occur through presynaptic modulation of the OSN-M/T synapse. We also find that surprisingly, pairing odors with LC activation leads to a sparsening rather than uniform suppression of the population response. We will further present data from mice expressing the fluorescent calcium indicator GCaMP2 in OSNs, to compare with the earlier results from intrinsic optical signals and confirm our findings.

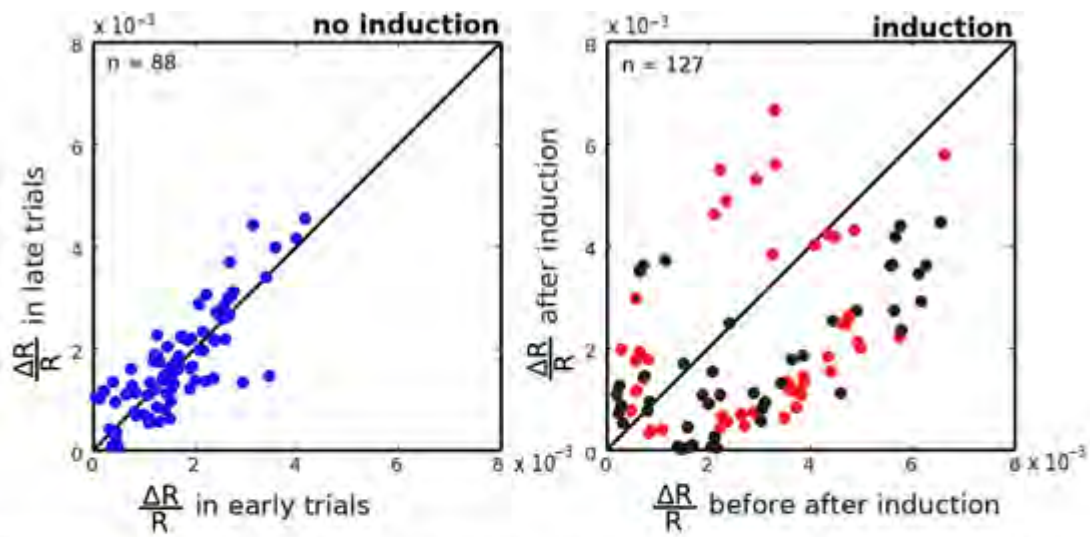

Intrinsic optical signals did not change over an equivalent number of trials in the control group (left panel). When plastic changes were induced by locus coeruleus stimulation, responsiveness in both hemispheres changed but more clearly in the ipsilateral hemisphere (right panel). Here, decreased response was found in 73% of glomeruli while in only 21% of the glomeruli we found increased response strength. R = reflectance in red light spectrum (~ 780 nm).

Electrophysiological characterization of proton-mediated activity in the mouse vomeronasal organ

Annika Cichy, Jennifer Spehr¹, Marc Spehr¹

¹RWTH Aachen University, Dept. Chemosensation, Institute of Biology II, Worringerweg 1, 52074 Aachen, Germany

The detection of a broad range of chemical cues in the environment is essential for all mammals. To address this critical task, the olfactory system in mice has evolved as a complex structure consisting of several subsystems. Among those, the mouse vomeronasal organ (VNO) plays an important role in the detection of pheromones and recognition of other social signals. However, the underlying mechanisms of signal transduction in the VNO remain largely unknown.

Here, we show the detection of extracellular protons by vomeronasal sensory neurons. To investigate the mechanisms involved, we performed whole-cell patch-clamp recordings from visually identified sensory neurons in acute tissue slices of the mouse VNO. We describe that acidic solutions of different pH values dose-dependently induce inward currents in voltage-clamp measurements. The same stimuli elicit robust action potential firing in current-clamp recordings. The pharmacological profile of the proton-induced responses and the ionic characterization of the underlying conductance indicate a possible involvement of different acid-sensitive ion channels and receptors.

On-going biochemical and molecular investigations as well as electrophysiological measurements will provide insight into the functional role of proton-detection in the vomeronasal organ of mice.

Can *Aedes aegypti* females avoid oviposition on *m*-cresol (100 ppm) in the presence of the deterrent isomer *p*-cresol?

Ali Afify, Giovanni C. Galizia¹

¹University of Konstanz, AG Galizia, Universitätsstraße 10, 78464 Konstanz , Germany

p-cresol (4-Methylphenol) is a volatile compound present in hay infusions and was previously found to deter oviposition in *Aedes albopictus* and *Aedes aegypti* mosquitoes. An increase in sensitivity towards *p*-cresol and to its isomer *m*-cresol (3-Methylphenol) was previously shown in a subpopulation of trichoid sensilla of *Ae. aegypti* females after blood feeding suggesting a role in oviposition for these substances. However, unlike its isomer, *m*-cresol has not yet been tested behaviourally. Here, we tested the oviposition response of gravid *Ae. aegypti* females towards *m*-cresol and *p*-cresol using a laboratory bioassay. Specifically, we tested: (1) a 100 ppm concentration of each compound separately against clean water, (2) a 1:1 mixture of both compounds against water, and (3) the two individual compounds against each other and water. We confirm the deterrent effect of *p*-cresol: Oviposition cups with a 100 ppm *p*-cresol received significantly lower number of eggs (33%) than cups containing water only (67%). *m*-cresol did not deter from oviposition (48.5%). The 1:1 mixture of both compounds showed a deterrent effect on *Ae. aegypti* oviposition (36%) showing that *m*-cresol in the mixture did not modify the deterrent effect of *p*-cresol. To our surprise, however, both *p*-cresol and *m*-cresol received significantly less eggs than water (16.5 and 26.5% respectively) when tested together in the same cage. Our data suggests that *m*-cresol per se is not an oviposition deterrent for *Ae. aegypti*, but gravid females could be able to avoid it only when an isomer deterrent is present.

Altered expression of gustatory signaling elements in the stomach of morbidly obese patients and obese mice

Patricia Widmayer, Markus Küpper², Michael Kramer³, Alfred Königsrainer⁴, Heinz Breer⁵

¹⁵Institute of Physiology, University of Hohenheim, Stuttgart, Germany

²³⁴University Hospital for General, Visceral and Transplant Surgery, Tübingen, Germany

Sensing of nutrients in the stomach is of crucial importance for the regulation of ingestive behaviors and deserves especial attention in the context of metabolic dysfunctions such as obesity. Cells in the gastric mucosa which express taste signaling elements are considered as candidate sensory cells capable to monitor the composition of ingested food and accordingly modulate gastrointestinal processes as well as the release of appetite controlling hormones, such as ghrelin. Analyzing tissue samples from human and murine stomach, we have identified transcripts for taste signaling elements, including the receptor T1R3 involved in reception of amino acids and carbohydrates, the fatty acid receptor GPR120, as well as receptors for amino acids and protein breakdown products, such as the receptors GPRC6A and CaSR and the peptone receptor GPR92. In addition, transcripts for the gustatory sensory marker proteins including the G protein gustducin, the effector enzyme PLC β 2 and the ion channel TRPM5 were identified. In histochemical approaches specific antisera for these gustatory sensory marker proteins were used to visualize candidate chemosensory cells in the human and murine gastric mucosa. In mice, cells expressing TRPM5 were found in the apical half of the gastric mucosa, whereas PLC β 2-positive cells were located more basally. In human, cells expressing TRPM5 and PLC β 2 were both situated in the basal half of the mucosa, probably coexpressed in the same cells.

In order to explore whether obesity might have an impact on the chemosensory capacity of gastric mucosal cells, tissue samples from morbidly obese and normal weight patients were compared. Real time PCR approaches revealed striking differences in the expression profiles for various gustatory elements in obese samples compared to controls. For GPR120 and TRPM5 the expression level was increased. Immunohistochemical approaches using an antiserum for TRPM5 were performed. It was found that the higher expression level was correlated with a higher number of TRPM5-cells in tissue samples from obese patients. For comparison, diet induced obese (DIO) mice were studied as a model for human nutritional studies. The analyses revealed parallels to human obese tissue. For example, the number of TRPM5-cells was significantly increased in DIO mice. Interestingly, subsequent studies showed that the higher number of TRPM5-cells, which are supposed to represent putative chemosensory cells, was accompanied with an increased number of ghrelin-positive cells in both species.

These findings indicate a relationship between the energy status and the number of candidate chemosensory cells in the gastric mucosa.

Phenotypic plasticity of synaptic-bouton numbers in the mushroom bodies of the highly polymorphic leaf-cutting ant *Atta vollenweideri*

Claudia Groh, Christina Kelber¹, Kornelia Grübel¹, Wolfgang Rössler¹

¹University of Wuerzburg, Behavioural Physiology and Sociobiology, Am Hubland, 97074 Wuerzburg, Germany

In both vertebrates and invertebrates numerous volumetric studies of brain neuropiles have been used to correlate aspects of behavioral plasticity associated with social life-style, behavioral transitions, aggression, or food preferences with the size in particular brain areas or the overall brain size. In insects, many of these studies have focused on the mushroom bodies (MBs), sensory integration centers involved in learning, the formation of associative memories, and orientation. In this study we investigated how body-size-dependent division of labor in the highly-polymorphic leaf-cutting ant *Atta vollenweideri* relates to both the absolute and relative volumes of the MBs and the absolute numbers of synaptic boutons formed by olfactory projection neurons (PNs) in the main olfactory input region of the MB calyx. Mass fills of PN output tracts from the antennal lobes revealed two concentric subdivisions of PN projections in the MB-calyx lip, a dense and non-dense region, most likely innervated by the medial and lateral olfactory output tracts. Synapsin-immunolabeled whole-mount brains of differently sized workers and synapsin-phalloidin double stained preparations revealed that the packing density of PN boutons and associated microglomeruli in the two subregions is independent of worker body size, even when compared between the smallest and largest workers. Whereas the absolute volumes of the MB calyx lip and the total brain volume positively correlated with head width, the relative volume of the MBs was significantly larger in small workers compared to large workers. However, despite a smaller relative volume the extrapolated absolute numbers of olfactory synaptic complexes in the MB calyx were significantly higher in large workers compared to small workers. This indicates that despite a smaller MB / brain ratio the synaptic computational capacity of the olfactory MB calyx is likely to be higher in large workers compared to small workers. Furthermore, the results demonstrate that pure volume data can be misleading without detailed information about the complexity of underlying neuronal circuits or absolute synapse numbers in the volume of interest. This is likely to be even more important in cases of comparisons across species.

Supported by DFG SPP 1392 to W.R.

Deorphanizing crypt neurons, the third type of olfactory receptor neurons

Gaurav Ahuja, Yuichiro Oka², Sigrun Korsching³

^{1,3}Institute for Genetics, Neurobiology, Zuelpicher strasse 47a, 50674 Koeln, Germany

² Division of Cell Biology and Neuroscience, Department of Morphological and Physiological Sciences, Faculty of Medical Sciences, University of Fukui, 23-3 Matsuoka-shimoaizuki, Eiheiji, Fukui 910-1193, Japan

The sense of smell (olfactory sense) plays a vital role in many essential behaviors such as prey detection, predator evasion and reproduction. The small teleost *Danio rerio* (zebrafish) has been established as model system to study vertebrate olfaction. In the olfactory epithelium of *Danio rerio*, there are three types of olfactory sensory neurons present: ciliated, microvillous and crypt neurons. Olfactory receptors present on ciliated and microvillous neurons have been studied extensively, but little is known about the receptors, transducing G-protein and further information processing in crypt neurons. Recent work from the lab showed Ora4 receptor to be exclusively expressed in crypt neurons by in situ hybridisation (Ora4). In order to analyze the subcellular localization of Ora4, we have generated and characterize a specific antibody against Ora4 olfactory receptor. The Western blot analysis with anti-ORA4 on protein extracts from olfactory epithelium revealed a unique band of expected molecular weight, which is exclusively present in the affinity purified lot, but absent in the pre-immune serum from the same animal. We find that this antibody co-localizes nearly completely with anti-S100 (a known marker for crypt neurons, although it is selective for crypt neurons only in fresh-frozen tissue sections). In contrast, anti-Ora4 solely labels the crypt neurons under all tested fixative conditions. This makes this antibody a more robust marker for the crypt cells. We report here that anti-Ora4 labeling is heavily concentrated in a spherical apical dot, which corresponds to the position of the crypt and enclosed cilia of the crypt neurons. In fact, this apical dot co-localizes exactly with anti-acetylated tubulin, a ciliary marker. A weak cytoplasmic staining with anti-Ora4 may represent immature receptor molecules en route to the plasma membrane. This subcellular localization supports Ora4 to be a functional olfactory receptor for crypt neurons. Gi1b has been suggested as potential signal-transducing G protein in crypt neurons. We show here, using different anti Gi antibodies that Gi1b exclusively co-labels with crypt neurons. We show the Gi1b promoter to drive specific reporter gene expression in transient transfection experiments, and are currently establishing a transgenic zebrafish line using a pGi1b-Venus construct. We are currently investigating a potential ligand for this receptor and the other downstream targets to unveil the neuronal circuit associated with crypt neurons.

Identification of a new murine olfactory subsystem

Sonja Oberland, Stefanie Gaab¹, Niels de Wit¹, Thomas Pelz¹, Eva M. Neuhaus¹

¹Cluster of Excellence NeuroCure, Charité Universitätsmedizin, Charitéplatz 1, CCO, 10117 Berlin

²FU Berlin, Fachbereich Biologie, Chemie, Pharmazie, Takustr. 3, 14195 Berlin

The murine olfactory system comprises several million olfactory sensory neurons (OSNs), each expressing one out of approximately 1200 functional olfactory receptor (OR) genes. Additionally there are known olfactory subsystems that express other receptor proteins in a distinct set of OSNs in the epithelium, like TAARs, TrpM5 or GC-D.

In our study we identified a new marker protein expressed in a particular subset of OSNs.

Initially we confirmed high expression of this candidate in the olfactory epithelium by quantitative PCR and western blot analysis. In further experiments we revealed subcellular expression in soma, dendrite, knob and cilia with immunohistochemical stainings. Until now we found no co-expression with either tested ORs or TAARs. Furthermore we identified a specific set of glomeruli in the ventral olfactory bulb expressing this protein.

In addition to these findings the protein is known to feature receptor-like functions in other murine tissues. We are currently analyzing co-expression of members of the olfactory signaling cascade in these neurons and investigate the functional relevance of this subsystem in knock-out mice.

Comparative transcriptomics of arthropod antennae

Katrin Christine Groh, Ewald Grosse-Wilde¹, Heiko Vogel², Marcus C. Stensmyr¹, Bill S. Hansson¹

¹Max Planck Institute for Chemical Ecology, Evolutionary Neuroethology, Hans Knoell Str. 8, 07745 Jena, Germany

²Max Planck Institute for Chemical Ecology, Entomology, Hans Knoell Str. 8, 07745 Jena, Germany

Chemosensory detection is one of the most important abilities of living organisms. In most cases it is crucial for orientation as well as the localization of food sources or mating partners. The characteristics of available olfactory cues depend heavily on the surrounding medium and therefore the inhabited environment. Substantial changes in this environment, as for example caused by a lifestyle change from aquatic to terrestrial therefore effect tremendous adaptations in chemosensation as the transporting medium changes its chemical and physical properties. Arthropods exhibit a variety of such adaptations dependent on available chemical cues according to their lifestyle. This adaptability can be retraced to the early stages of arthropod evolution. According to fossil records it can be assumed that the hexapods split from an arthropod progenitor and left the marine habitat in the very late Silurian 416 million years ago, shifting the range of chemical stimuli solved in water to air-borne substances. However, at least five crustacean lineages independently followed in the transition from water to land, among them the *Coenobita* 20 Mya. Despite the long time of independent development, insects and crustaceans share a connatural organization of olfactory organs and brain architecture. As the antennae are the main olfactory organ of arthropods we chose two hermit crab species, the aquatic *Pagurus bernhardus* and the terrestrial *Coenobita clypeatus* to compare their antennal transcriptomes to the tobacco hornworm *Manduca sexta* in order to trace the specificity of lifestyle dependent adaptations on a molecular level.

Vinegar fly behavior towards odor mixtures – an additive approach

Michael Thoma, Markus Knaden¹, Bill S. Hansson¹

¹Max-Planck-Institute for Chemical Ecology, Department of Evolutionary Neuroethology, Hans-Knöll-Straße 8, 07745 Jena, Germany

In their natural environment insects rarely encounter odors as monomolecular compounds but rather in the form of mixtures of many different compounds in varying concentration ratios. While there is ample evidence for the relevance of complex odor blends in ecological interactions and for interactions of chemicals in respect to both peripheral and central neuronal processing, a fine-scale analysis of rules governing innate behavioral responses towards odor mixtures is lacking. In this study, we use the Flywalk to examine, whether innate binary mixture responses can be predicted on the basis of the responses towards their monomolecular constituents. The Flywalk paradigm allows the investigation of instantaneous behavioral responses of individual vinegar flies to well-defined chemical stimuli and temporally coherent mixtures at a high temporal resolution.

After assessment of dose-response characteristics of individual compounds, we chose four compounds that are attractive at an intermediate concentration. We show that every possible binary mixture of these compounds is at least as attractive as the more attractive one of the two constituents. Next, we addressed the question, how an increase in concentration of one constituent beyond its behavioral optimum affects the mixture response. We show that by adding one component in an unattractive high concentration to the mix the binary mix becomes less attractive. However, this is not an effect of general over-excitation of the olfactory system. When we in addition increase the concentration of the second compound to a higher but still attractive concentration – i.e. a further increase in total stimulus energy – the mix becomes attractive again. Therefore, there appears to be elaborate information processing even at the upper end of the olfactory system's dynamic range. In a further step, we examine mixtures of attractants with a reportedly repellent compound. In these experiments, mixture responses were consistently lower than the responses to the attractive constituent. The reduced responses in addition were accompanied by an increased response latency.

In summary, our data obtained with a limited set of compounds demonstrate that innate responses towards mixtures, despite being clearly distinguishable from the responses towards mixture constituents in many cases, are not entirely unpredictable on the basis of constituent responses. Although our results admittedly only cover a tiny spot in the odor space an organism may encounter in its natural environment, they may nevertheless serve as a framework for future investigations of behavioral responses towards mixtures of higher complexity and ecological relevance.

Receptors for protein breakdown products in gastric endocrine cells and in gustatory sensory cells

Désirée Haid, Patricia Widmayer¹, Heinz Breer¹

¹University of Hohenheim, Institute of Physiology, Garbenstraße 30, 70599 Stuttgart, Germany

Sensing of proteins and their breakdown products in the luminal content of the stomach is essential for regulating the digestive activities, including the release of gastrin and somatostatin, hormones which are of fundamental importance for controlling the gastric activities. The molecular basis for eliciting and tuning the release of these hormones and consequently the secretion of hydrochloric acid and pepsinogen according to the protein content in the gastric lumen is still elusive. Our previous studies have shown that in mice the gastrin-secreting G-cells express receptor types which are responsive to amino acids. Since the pig is considered as more suitable model for studying gastro-physiological aspects relevant for men, we have analysed G-cells and D-cells in the gastric antrum of men, swine and mouse for receptors capable to recognize protein breakdown products in the luminal content. The molecular phenotyping of G- and D-cells revealed that in all three species the receptors GPRC6A and CaSR were expressed. Based on the physiological implications of G- and D-cells in gastric processes which are specifically geared to protein digestion it has been assumed that in addition to amino acids receptors these enteroendocrine cells may be able to sense proteins. Recently, the receptor-type GPR92 was deorphanized and found to be responsive to protein hydrolysates; accordingly it was called peptone receptor. During the course of our study, we found that the peptone receptor GPR92 was in fact expressed in G- and D-cells. It is conceivable that this receptor type enables the cells to sense protein breakdown products; thus it may be a key element to adjust the hormone release from G- and D-cells according to the protein content in the gastric lumen.

Recent findings indicate that putative chemosensory cells of the gastrointestinal mucosa and gustatory cells in the taste buds share similar molecular elements for recognizing and transducing nutrient stimuli. Therefore, it was of immediate interest to investigate whether the peptone receptor GPR92, which seems particularly suitable for the endocrine cells in the stomach, is also expressed in gustatory sensory cells in the oral cavity. Using immunohistochemical approaches it was found that a large population of cells in taste buds of murine taste papillae was labeled with a GPR92-antibody. A molecular phenotyping of GPR92-cells revealed that the vast majority of GPR92-immunoreactive cells express PLC β 2, a key element of the taste cascade, and can therefore be classified as Type II receptor cells. A subpopulation of Type II cells which express the receptor heterodimer T1R1/T1R3 is supposed to confer the umami taste which is predominantly elicited by protein-rich foods. Therefore, we investigated whether GPR92 may be expressed in the same sensory cells as T1R1. It was found that GPR92 is in fact expressed in the majority of T1R1-positive taste cells. These results indicate that in addition to amino acids also protein breakdown products may activate this cell type and thus contribute to the umami taste. The findings of this study concentrate that amino acid responsive receptors and the peptone receptor GPR92 are coexpressed in gastric endocrine cells as well as in gustatory sensory cells and may therefore contribute to the responsiveness of these cell types to protein breakdown products.

This work was supported by the Deutsche Forschungsgemeinschaft, BR 712/25-1.

Serotonin association with feeding regulation in ants

Agustina Falibene, Roxana Josens², Wolfgang Rössler¹

¹University of Würzburg, Biozentrum, Department of Behavioral Physiology and Sociobiology, Am Hubland, 97074 Würzburg, Germany

²Grupo de Estudio de Insectos Sociales. IFIBYNE-CONICET. FCEN, University of Buenos Aires, Argentina

Serotonin (5-HT) plays an important role in the control and integration processes involved in feeding modulation in both vertebrates and invertebrates. Pharmacological studies have demonstrated that the administration of this amine promotes anorexic effects on different insects. In the nectar-feeding ant *Camponotus mus*, 5-HT depresses feeding by affecting the activity of the muscles involved in fluid intake, the sucking-pump muscles. Here we studied the 5-HT association with tissues and neuronal ganglia related to this behaviour and its regulation. We analysed the presence of serotonergic neurons in the Frontal Ganglion (FG) -which innervates both sucking-pump muscles and the alimentary canal- and the Subesophageal Ganglion (SEG) -which controls the mouthparts and receives gustatory and mechanosensory inputs in insects-. Furthermore, we studied 5-HT association with the sucking-pump muscles and the alimentary canal of these ants. Immunohistochemical studies all along the alimentary canal revealed 5-HT-like immunoreactive processes on the foregut (esophagus, crop and proventriculus), while the midgut and hindgut lacked 5-HT innervation. Although both the FG and the SEG contained 5-HT immunoreactive cell bodies, direct serotonergic innervation in the sucking-pump muscles was absent. Altogether, the results indicate that 5-HT plays an important role in the regulation of food transport throughout the gut in ants and acts most likely via indirect regulation of the sucking-pump activity.

Molecular basis of sex pheromone detection in *Heliothis virescens*

Jürgen Krieger, Pablo Pregitzer¹, Heinz Breer¹

¹University of Hohenheim, Institute of Physiology, Garbenstr. 30, 70599 Stuttgart, Germany

Mate finding in many insects highly depends on female-released sex pheromone blends and the accurate and sensitive detection of the major and minor components by the males. In male moths, the basis for the remarkable pheromone-sensing abilities are specifically equipped olfactory “hairs” on the antennae. These sensilla trichodea house the dendrites of pheromone-responsive olfactory sensory neurons (Ph-OSNs), which are endowed with specific pheromone receptors (PRs). The dendrites are bathed in the sensillum lymph which contains special pheromone binding proteins (PBPs); the proteins are supposed to capture pheromone molecules from the air and mediate the transfer towards the chemosensory dendritic membrane and probably even to the receptor proteins. In this process the so-called “sensory neuron membrane proteins” (SNMPs) may play a central role. They may operate as docking sites for PBP/pheromone complexes and/or contribute to the release of pheromones to PRs. In the moth *Heliothis virescens* the females release a blend containing (Z)-11-hexadecenal (Z11-16:Ald) as the major and (Z)-9-tetradecenal (Z9-14:Ald) as principle minor sex pheromone component. Our previous results provide compelling evidence for an interplay of the pheromone receptor HR13 and the binding protein PBP2 as a basis for a sensitive detection of Z11-16:Ald by the males. In addition, we have found that SNMP1 and HR13 are co-expressed in pheromones sensitive neurons. To get more insight concerning the specific function of SNMP1 we have reconstituted the pheromone detection system in cell a culture system using modified HEK293 cells to express HR13 and/or SNMP1 and purified PBP2 to provide the pheromone. With respect to the question whether the mechanisms underlying the detection of the major and minor sex pheromone components are similar attempts were made to characterize molecular elements, which are involved in the detection of Z9-14:Ald.

Spatial representation of the olfactory output in *Drosophila*

Amelie E. E. Baschwitz, Antonia Strutz¹, Bill S. Hansson¹, Silke Sachse¹

¹Max Planck Institute for Chemical Ecology, Department of Evolutionary Neuroethology, Hans-Knöll-Straße 8, 07745 Jena, Germany

Finding food sources, good mating partners as well as oviposition sites and avoiding danger is essential for the fruit fly *Drosophila melanogaster* - just like for other insects. This is relying on the sense of smell. Olfactory sensory neurons (OSNs), housed in sensilla on the antennae, express one type of odorant receptors (ORs) each. The binding of an odor molecule to a specific OR evokes neuronal activity, which is transferred via the OSNs to distinct brain structures, so-called olfactory glomeruli, of the antennal lobe, the first olfactory processing center in the fly brain. Within the glomeruli synaptic connections to second order neurons (projection neurons, PNs) as well as interconnections between local interneurons take place. The latter is assumed to modulate the input signal via excitation and/or inhibition on particular synaptic terminals from OSNs to PNs. The modulated input signal is transferred via PNs to higher brain centers, like the mushroom body calyx and/or the lateral horn, leading to odor-guided behavior.

In the antennal lobe each OSN type innervates one corresponding glomerulus – creating a topographic map of odor reception. For further anatomical characterization of the innervation pattern in higher brain centers of inhibitory and excitatory PNs we used photoactivatable GFP (PA-GFP). This method enables labeling of single neurons by irradiation of single somata or labeling of all PNs innervating a specific glomerulus. Of special interest are PNs innervating glomeruli that are predominantly activated by odors that elicit either aversive or attractive behavior. Photoactivation is used to generate a topographic map of these PNs innervating distinct or overlapping regions in higher brain centers.

This study is supported by the Max Planck Society, the BMBF and the IMPRS.

Identification of PDZ-protein based microdomains in vomeronasal sensory neurons

Bastian Henkel, Tobias Ackels³, Marc Spehr³, Eva M. Neuhaus²

¹FU-Berlin, Fachbereich Biologie, Chemie, Pharmazie, Takustr. 3, 14195 Berlin, Germany

²Cluster of Excellence NeuroCure, Charité – Universitätsmedizin Berlin, CCO 10117 Berlin, Germany.

³Department of Chemosensation, Institute for Biology II, Rheinisch-Westfälische Technische Hochschule Aachen University, Aachen, Germany.

Many vertebrates use their vomeronasal organ to detect pheromones as an important part of intra species communication. Signal transduction in the vomeronasal organ takes place in the microvilli of the sensory neurons and utilizes a complex signal transduction cascade. These sensory cells host two different types of G-Protein coupled vomeronasal receptors (V1R and V2R). Every cell expresses either one specific V1 or V2 receptor and feature microvilli at their dendritic tip, where the receptors are located.

Here we investigate the relevance of scaffolding proteins for signal transduction in the mouse vomeronasal organ. PDZ-domain containing scaffolding proteins play an essential role in the macromolecular organisation of many cellular signal transduction processes and establish functional microdomains within sub-cellular compartments. Using immunohistochemical methods we show that different PDZ-domain containing scaffolding proteins are highly enriched in the microvilli of vomeronasal sensory neurons and with the help of super-resolution microscopy we provide first optical evidence of signaling microdomains at the side of signal transduction in the vomeronasal sensory neurons. Further we apply biochemistry methods to reveal potential protein-protein interactions between the PDZ-protein EBP50 and members of the vomeronasal signaling cascade using customized peptide microarrays. Our future aim is to elucidate the physiological role of EBP50 and other scaffolding proteins in knock out animals.

Chemo- and thermosensory signaling in the Grueneberg ganglion

Joerg Fleischer, Katharina Mamasuew¹, Sabrina Stebe¹, Heinz Breer¹

¹University of Hohenheim, Institute of Physiology, Garbenstrasse 30, 70599 Stuttgart, Germany

The Grueneberg ganglion (GG) - a cluster of neurons in the anterior nasal region - projects axonal processes to the olfactory bulb and expresses the olfactory marker protein (OMP) as well as distinct olfactory receptors, suggesting a potential olfactory function of the GG. Searching for odorous cues stimulating the GG, we have recently identified a limited set of defined odorants – in particular dimethyl pyrazines - which activate murine GG neurons. Responsiveness to these odorants was confined to a larger subset of GG neurons which is characterized by the expression of the olfactory receptor V2r83, the transmembrane guanylyl cyclase subtype GC-G and the cyclic nucleotide-gated ion channel CNGA3. Experiments with knockout animals disclosed that GC-G and CNGA3 are important for odor-evoked GG responses.

In addition to odorants, GG neurons were also found to be activated by another environmental stimulus: cool ambient temperatures. Attempts to unravel the relevant signaling mechanisms revealed that almost all V2r83-/GC-G-/CNGA3-positive GG neurons responded to coolness, i.e, the same subset of GG neurons is activated by coolness and the above mentioned odorants. Experiments with GC-G- and CNGA3-deficient mice demonstrated that these elements contribute to coolness-evoked responses in the GG. Searching for a potential thermosensor, expression of the thermosensitive ion channel TREK-1 was observed in numerous GG neurons.

Sharing common transduction elements such as GC-G and CNGA3, attempts were made to evaluate whether cross-talks between the coolness-induced and the odorant-activated signaling pathway exist in GG neurons. The results indicate that temperature stimuli markedly affect odor-evoked responses in the GG.

This work was supported by the Deutsche Forschungsgemeinschaft.

Tachykinin-related and myoinhibitory peptides co-express in the brain of *Tribolium castaneum*

Milosz Krala, Carsten M. Heuer¹, Joachim Schachtner¹

¹Philipps-Universität Marburg, Dept. Biology, Animal Physiology, 35032 Marburg, Germany

Neuropeptides are the largest, most diverse and probably the oldest group of signaling molecules. In insects, neuropeptides are known to orchestrate endocrine events and behavioral actions and are assumed to have wide-ranging modulatory functions, altering the effect of 'classical' transmitters. However, the exact functions of neuropeptides in neural circuits and experience-dependent plasticity effects in neuronal populations remain poorly understood. Another enigmatic aspect is the occurrence of multiple neuropeptide families in neuronal subsets and even single neurons. We approach these questions by immunohistological and mass spectrometric investigations. We focus on the distribution and co-localization of two major neuropeptide families – tachykinin-related peptides (TKRPs) and myoinhibitory peptides (MIPs) – in the brain of the red flour beetle, *Tribolium castaneum*. The total number of immunopositive neuronal somata across the brain was counted for each peptide – resulting in a distribution map that displays sites of co-localization, indicates possible functional roles for both neuropeptides, and allows comparisons to other insect taxa. From this information, MIPs and TKRPs in *Tribolium* are proposed to be involved in first-order processing of sensory inputs, in integrative functions of higher brain centers, and in the regulation of growth. Moreover, preliminary data show changes in the expression and distribution of the two neuropeptide families during the first week after adult eclosion. We now started to investigate this phenomenon, to obtain a better understanding of age-related plasticity effects in *Tribolium*.

This work was funded by the DFG priority program 1392 "Integrative Analysis of Olfaction" (SCHA 678/13-1).

The *Drosophila melanogaster* olfactory co-receptor Orco mediates odorant sensitivity in adult flies

Thomas Tam Giang, Andrea Schneider¹, Henrike Scholz¹

¹University of Cologne, Animal physiology, Zùlpicherstr. 47b, 50674 Cologne, Germany

The insect and vertebrate olfactory pathway is organized in a generally similar fashion. Both express one olfactory receptor (OR) gene per olfactory receptor neuron (ORN). ORNs expressing the same OR gene converge onto the same glomeruli in the antennal lobe (insects) or olfactory bulb (vertebrates). In contrast to vertebrates, insects have an additionally present olfactory co-receptor (ORCO) that is encoded by the *orco* gene. This receptor has been shown to be present in many insect species including *Drosophila melanogaster*. So far it is not known how this co-receptor contributes to the relevant content of the olfactory information for the live animal. In order to dissect the function of the ORCO, we utilized Orco loss-of-function mutants in olfactory preference experiments. In general, complex odour mixtures are more attractive for adult *Drosophila melanogaster* than single odours. Here we show that Orco loss-of-function mutants cannot distinguish between two similar complex odorant mixtures containing naturally attractive odours. In addition, ORCO is required for olfactory preference at low attractive odorant concentrations, while aversive behaviour is ORCO independent at high odorant concentrations. Furthermore, ORCO loss-of-function seems to be related to decreased sensitivity to acetic acid, ethyl acetate and ethanol in a concentration dependent manner. However, ethanol could be processed in an at least partly different way, which may include rewarding properties of ethanol at high concentrations. To address the question whether ORCO plays a functional role in perceptual odour quality evaluation, two similar attractive single odours were tested against each other. Indeed ORCO loss-of-function mutants are unable to distinguish between the two odours. We provide evidence that ORCO contributes to the sensitivity of olfaction and possibly has a function in perceptual odour quality evaluation.

Functional characterization of alternative signal transduction pathways in olfactory receptor neurons

Paul Scholz, Sabrina Baumgart¹, Katharina Klasen¹, Benjamin Kalbe¹, Hanns Hatt¹

¹Ruhr Universität Bochum, Lehrstuhl für Zellphysiologie, Universitätsstr. 150, 44801 Bochum, Germany

The mammalian olfactory system is organized into different cellular and molecular subsystems, thus ensuring the accurate detection of a vast variety of complex chemical cues. It is generally agreed that in olfactory sensory neurons (OSNs) the binding of odorant molecules to their specific olfactory receptor (OR) triggers a cAMP-dependent signaling cascade activating cyclic-nucleotide gated (CNG) channels. However, considerable controversy dating back more than 10 years has surrounded the question of whether phosphoinositide (PI) signaling plays a role in mammalian olfactory transduction. Early studies of PI signaling in olfaction focused solely on the classical phospholipase C (PLC) dependent pathway, demonstrating that odorants can elevate levels of inositol triphosphate (IP3). In addition, our recent study proved that odorants stimulate both, PLC and phosphatidylinositol 3-kinases (PI3Ks), in the dendritic knob and in olfactory cilia of rodent OSNs. This second sensory pathway activated by ORs might reflect a system to fine-tune odor responses.

In this project, we aim at characterizing the dual pathway of olfactory signaling in more detail. For this purpose, we will analyze the distribution of PI signaling upon specific odor stimulation in living OSNs via translocation imaging. The use of mOR-EG-GFP transgenic mice will allow for specific analysis of OSNs expressing the well-characterized olfactory receptor mOR-EG, which can be activated by different odorants. To investigate PI signaling in OSNs, we will use adenoviral vectors carrying two different fluorescently tagged proteins, the pleckstrin homology (PH) domains of phospholipase C (PLC) and the general receptor of phosphoinositides (GRP1), to monitor PI activity in the murine olfactory epithelium (OE) *in vivo*. Moreover, we will elucidate the account of the individual PI signaling proteins PLC and PI3K for olfactory transduction through Ca²⁺ imaging experiments of specific OSNs. Furthermore, we will monitor the effects of PI signaling on the electrophysiological output of OSNs using the recently established patch clamp technique of single neurons in acute OE slices of mOR-EG-GFP transgenic mice. Besides the physiological characterization, we will perform interaction studies using peptide microarrays, DuoLink experiments and *in vivo* co-immunoprecipitation to analyze the detailed components of the dual signaling pathway and their individual circuits.

Scaffolding proteins in olfaction

Fabian Jansen, Sabrina Baumgart¹, Benjamin Kalbe¹, Mark Spehr², Christian Herrmann³, Willem Bintig⁴, Hanns Hatt¹, Eva Neuhaus⁴

¹Department of Cell Physiology, Faculty for Biology and Biotechnology, Ruhr-Universität Bochum, Germany

²Department of Chemosensation, Institute for Biology II, RWTH-Aachen University, Aachen, Germany

³Department of Physical Chemistry I, Ruhr-Universität Bochum, Germany

⁴Neuroscience Research Center, Cluster of Excellence NeuroCure, Charité Universitätsmedizin Berlin, Charitéplatz 1, 10117 Berlin, Germany

Mammalian olfactory signaling is dependent on various proteins and fine-tuned through different processes. Most of the essential components are already known but the detailed organization of this complex system has yet to be understood. In our recent study we identified the multiple PDZ domain protein MUPP1 as a potential scaffolding protein candidate for olfactory signaling. Through large-scale peptide microarrays we could show numerous interactions between the 13 PDZ domains of MUPP1 and different murine olfactory receptor C-termini of various subfamilies. Co-immunoprecipitations validated the interactions between MUPP1 and the most important signaling proteins *in vivo* and led to the assumption that an olfactory PDZome is organized by the scaffold MUPP1. Furthermore co-immunoprecipitations in juvenile mice showed no differences in binding properties in comparison to the adult mice. To functionally show that olfactory signaling is PDZ-dependent we established patch clamping of olfactory sensory neurons in acute slices of transgenic mOR-EG mice. We also created a small inhibitory peptide which disrupts the interaction between the mOR-EG receptor and MUPP1 and injected it through the patch pipette into the neuron. After uncoupling the interaction between the mOR-EG receptor and MUPP1 the odor-evoked current amplitudes were strongly reduced and the adaptation was impaired, whereas a control peptide did not affect olfactory signaling. In conclusion, we confirmed that an olfactory signalosome is mediated by MUPP1 in olfactory sensory neurons and showed that accurate olfactory signaling is a PDZ dependent mechanism.

Delta-gamma phase-amplitude coupling in the mouse whisker barrel cortex is driven by the olfactory bulb

Junji Ito, Snigdha Roy^{2,4}, Ying Cao², Max Fletcher², Sonja Grün^{1,3}, Detlef Heck²

¹Institute of Neuroscience and Medicine (INM-6), Forschungszentrum Juelich, Juelich, Germany

²Department of Anatomy and Neurobiology, University of Tennessee Health Science Center, Memphis, TN, USA

³Theoretical Systems Neurobiology, RWTH Aachen University, Aachen, Germany

⁴Equal contributors

Respiration and whisking are both rhythmic behaviors within a frequency range between 1 and 20 Hz. The rhythms of whisker movements and respiration are strongly correlated when they are both in their resting states characterized by delta band frequencies (below ~ 5 Hz) [1]. It has been reported that neuronal activities show distinct oscillations in the same frequency band both in the whisker barrel cortex [2] and the olfactory bulb [3]. There is increasing evidence that amplitude modulations in the gamma frequency band are phase-locked to the delta/theta rhythm [4]. Several studies have linked theta-gamma phase-amplitude coupling to cognitive processes [5]. Here we report that delta frequency LFP oscillations in the whisker barrel cortex are linked to respiratory rhythm via olfactory bulb activity during normal (2-4 Hz, data not shown) and accelerated breathing (>4Hz) induced by exposure to hypoxic air (Fig. 1A,B). We confirmed in tracheotomized mice, where the airflow through the nose canal was modulated independently from the voluntary respiration, that this LFP-respiration correlation was not an artifact caused by electrode displacements due to the breathing motion but directly related to the rhythm of the airflow per se. Furthermore, LFP oscillations occurring in parallel in the gamma frequency band (64-128 Hz) were amplitude-modulated in phase with the breathing frequency (Fig. 1C). After removal of the olfactory bulb, the LFP-respiration correlation in the delta band LFP oscillations was considerably reduced (data not shown), and the respiration-locked amplitude modulation in the gamma band shifted to lower frequencies. Our findings imply that mice respiratory activity directly modulates delta/theta band LFP oscillations in the somatosensory whisker barrel cortex through respiration-locked olfactory bulb activity and indirectly, through phase-amplitude coupling, gamma band power.

Figure caption: A. Respiration (top) and LFP (bottom two) traces during accelerated breathing. The respiration signal was recorded with a thermistor and its unit is arbitrary. LFP recording sites were 610 μm apart. Solid curves are the signals after band-pass filtering in 0.5-10 Hz. Raw LFP signals are plotted with shaded colors. B. Auto-correlation of the respiration and the LFP signals (top) and cross-correlation between the respiration signal and each of the LFP signals (bottom) during accelerated breathing. C. Summary of phase-amplitude coupling analysis on the LFP data. The strength of the coupling between the phase of the respiratory frequency and the amplitude of a range of frequencies between 1 and 256 Hz was assessed in terms of the mean vector length. Analysis was performed on 52 and 14 LFP segments (duration: 50 sec) from normal and bulbectomized mice, respectively. The fraction of significant samples is plotted as a function of amplitude frequency.

References:

1. Cao et al. (2012). Dynamic correlation between whisking and breathing rhythms in mice. *J Neurosci* 32(5), 1653–9.
2. Poulet & Petersen (2008). Internal brain state regulates membrane potential synchrony in barrel cortex of behaving mice. *Nature* 454(7206), 881–5.
3. Fontanini & Bower (2006). Slow-waves in the olfactory system: an olfactory perspective on cortical rhythms. *Trends Neurosci* 29(8), 429–37.

4. Buzsáki & Wang (2012). Mechanisms of gamma oscillations. *Annu Rev Neurosci* 35, 203–25.
5. Canolty & Knight (2010). The functional role of cross-frequency coupling. *Trends Cogn Sci* 14(11), 506–15.

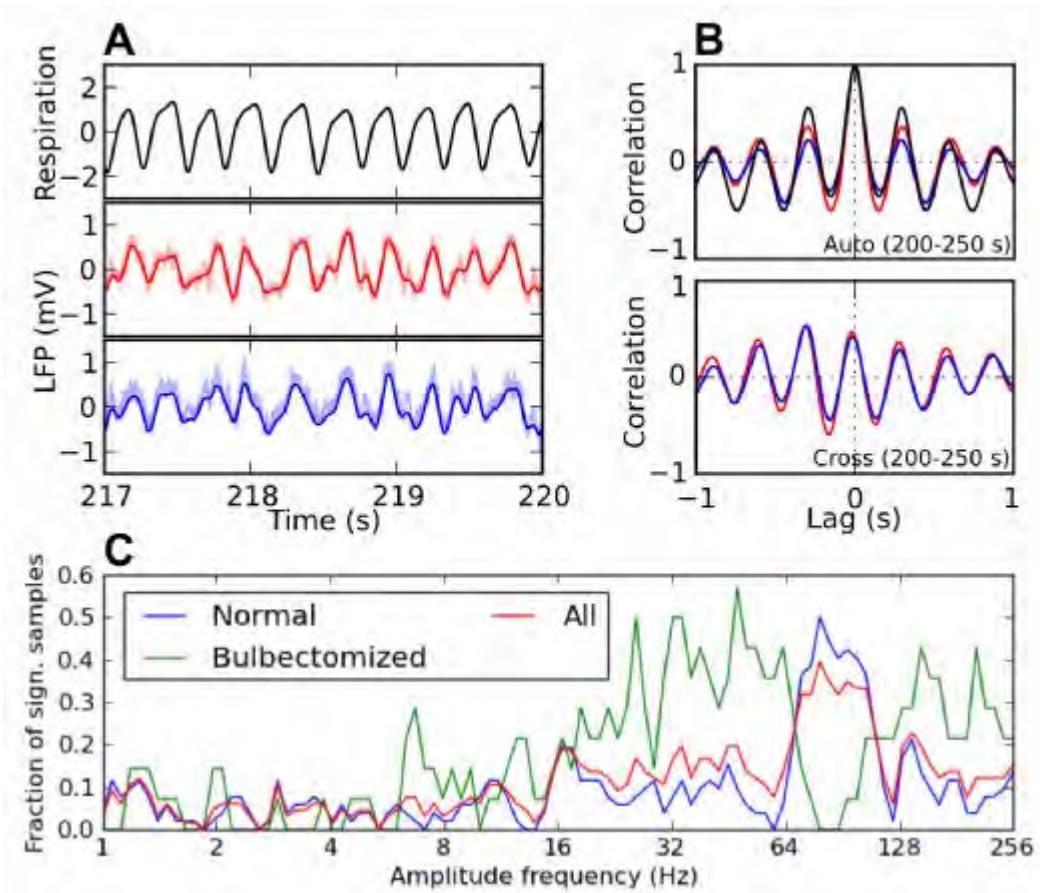

Untypical connectivity from olfactory sensory neurons expressing OR37 into higher brain centers visualized by genetic tracing

Jörg Strotmann, Andrea Bader¹, Heinz Breer¹

¹University of Hohenheim, Physiology, Garbenstrasse 30, 70593 Stuttgart, Germany

The OR37 subfamily of odorant receptors (OR) exists exclusively in mammals. In contrast to ORs in general, they are highly conserved within and across species. These unique features raise the question, whether olfactory information gathered by the OR37 sensory cells is processed in specially designated brain areas. To elucidate the wiring of projection neurons from OR37 glomeruli into higher brain areas, tracing experiments were performed. The application of Dil onto the ventral area of the olfactory bulb, which harbors the OR37 glomeruli, led to the labeling of fibers not only in the typical olfactory cortical regions, but also in the medial amygdala and the hypothalamus. To visualize the projections from a defined OR37 glomerulus more precisely, transgenic mice were studied in which olfactory sensory neurons co-express the receptor subtype OR37C and the transsynaptic tracer Wheat Germ Agglutinin (WGA). WGA became visible not only in the OR37C sensory neurons and the corresponding OR37C glomerulus, but also in cell somata located in the mitral/tufted cell layer adjacent to the OR37C glomerulus, indicating a transfer of WGA onto projection neurons. In the brain, WGA immunoreactivity was not detectable in typical olfactory cortical areas, but instead in distinct areas of the medial amygdala. Detailed mapping revealed that the WGA immunoreactivity was restricted to the posterior-dorsal subnucleus of the medial amygdala. In addition, WGA immunoreactivity was visible in some well circumscribed areas of the hypothalamus. These results are indicative for a unique connectivity from OR37C sensory cells into higher brain centers.

This work was supported by the Deutsche Forschungsgemeinschaft

Characterization of the Iontransporter NKCC1 in the Field of Chemosensation

Claudia Haering, Janine Wäring¹, Hanns Hatt¹

¹Ruhr-Universität, Lehrstuhl für Zellphysiologie, Universitätsstr.150, 44801 Bochum, Germany

The olfactory sense is mainly regulated through a cAMP-dependent signaling cascade. First, an odor binds to a G protein-coupled receptor and activates an adenylyl cyclase III which generates cAMP. A cyclic nucleotide-gated channel is opened through binding of cAMP and leads to an influx of sodium and calcium ions into the cell. This cation influx causes the initial depolarization of the cell which is increased by a following chloride efflux. The calcium binds to a chloride channel which undergoes a conformational change and enables the efflux of chloride. This so called chloride boost during depolarization of olfactory sensory neurons still remains unclear. The chloride channel TMEM16b/Ano2 might be responsible for the chloride efflux, but its role in olfaction is discussed in literature. In addition, how is the intracellular chloride concentration achieved in olfactory neurons? Several publications demonstrated that the chloride concentration is much higher in olfactory neurons, especially in the knob, compared to surrounding cells and the mucus. NKCC1 is a candidate which fits the role of an ion transporter that causes the high chloride concentration inside olfactory neurons. NKCC1 is a 12 membrane spanning symporter of one sodium, one potassium and two chloride ions. The expression of NKCC1 is confirmed in the olfactory epithelium of mice, especially in olfactory neurons. However, the function of NKCC1 is controversially discussed in literature. In our project we want to characterize NKCC1 knockout mice, thereby addressing the question whether NKCC1 is involved in olfaction and olfactory neurogenesis. On the one hand we are going to use chloride imaging of acute slices of the olfactory epithelium of knockout and wild type mice. Chloride imaging is a highly sensitive method which enables odor response measurements and simultaneous quantification of the chloride concentration in cells. On the other hand morphological studies and RNA fluorescence in situ hybridization (RNA FISH) experiments will give us information about the role of NKCC1 in neurogenesis. Our first studies showed differences in the morphology of the turbinates and the neuronal layer of the olfactory epithelium of NKCC1 knockout compared to wild type mice leading to the question whether NKCC1 plays a role in the continuous replacement of olfactory sensory neurons.

Variation in the human olfactory subgenome and its impact on olfactory perception

Jonas Kuklan, Günter Gisselmann¹, Thomas Hummel², Hanns Hatt¹

¹Ruhr-University Bochum, Department of Cell Physiology, Universitätsstr. 150, 44801 Bochum, Germany

²University of Dresden Medical School, Dept. of Otorhinolaryngology, Dresden, Germany

The olfactory receptors (ORs) are a family of G-Protein coupled receptors that provide the molecular basis for the detection of volatile odorant molecules by the central nervous system. In humans, the *OR* gene family comprises about 400 functional genes and about 600 non-functional pseudogenes. Furthermore, the *OR* gene family shows a high degree of genetic variability between individuals. Common single nucleotide polymorphisms (SNPs) and copy number variants (CNVs) lead to specific patterns of functional and non-functional *OR* genes in each individual subject, resulting in “different noses for different people” (Menashe *et al.*, Nat Genet, 2003).

At the same time, it has long been known that people differ in their ability to perceive certain odorants. In the most striking cases, subjects are completely devoid of the ability to perceive certain odorants, although their sense of smell functions normally in general. This phenomenon is known as specific anosmia and has been shown to have a genetic basis in some cases.

We obtained genomic DNA samples from subjects with a specific anosmia for one of several odorants. We then used massive parallel sequencing (MPS) techniques to look for genetic variation in the human *OR* repertoire that could explain the occurrence of specific anosmias. Experiments were performed on pools of DNA samples to maximize throughput and cost-efficiency. In total, twenty specific anosmias were tested for their association to genetic variation in the *OR* repertoire. Results indicate that many of these specific anosmias may be complex traits which are caused by the combined effects of several genetic and/or environmental factors.

Acknowledgements: This project was funded by SPP 1392 "Olfaktorik" of the Deutsche Forschungsgemeinschaft (DFG).

Involvement of several TRP channels in trigeminal odor sensation

Jessica Kyereme, Matthias Lübbert^{1,2}, Nicole Schoebel³, Hanns Hatt¹

¹Ruhr University Bochum, Department of Cell Physiology, Universitätsstr. 150, 44780 Bochum, Germany, ²Ruhr University Research School, ³Leibniz Research Center for Working Environment and Human Factors, Ardeystr. 67, 44139 Dortmund, Germany

To date, the detection of different odorants by the olfactory system is well investigated and understood. However, much less is known about the activation of the trigeminal system (TS) caused by the majority of odorants in higher concentrations. Some members of the transient receptor potential (TRP) superfamily of ion channels are highly expressed in trigeminal sensory neurons.

In order to investigate if different TRP-channels are involved in the detection of several odorants by the TS, we used primary cultures of rat trigeminal sensory neurons (TSN's) to perform an overlapping study with classical TRP channel agonists and different odorants using calcium imaging. The findings of this study gave first hints to an involvement of TRPV1, TRPM8, and TRPA1 in the detection of the odorants we used. To obtain a better understanding of the odorant-effect on the specific TRP channels, we performed current clamp measurements on TSN's during which we applied different odorants in the presence and absence of respective antagonists. Although the blockers failed to completely inhibit odorant induced depolarisations, the effects on the membrane potentials were significantly decreased in the presence of these substances. Finally, we used CHO cells heterologously expressing either rTRPA1, rTRPV1, or rTRPM8 performing whole-cell measurements, in order to test the direct effect of the odorants used on the respective channel proteins.

Our experiments indicate that TRPV1, TRPM8, and TRPA1 seem to play crucial roles in the detection of different odorants via the TS. A better understanding of the odorant interaction with different TRP channels might lead to a more detailed understanding of the properties of the TS.

Taste Receptors in mammalian Spermatozoa: Functional role of Tas1r1 in regulating basal Calcium and cAMP concentrations in Spermatozoa

Andrea Wartenberg, Dorke Meyer¹, Anja Voigt², Patricia Widmayer³, Heike Borth¹,
Andreas Breit¹, Ulrich Boehm⁴, Thomas Gudermann¹, Wolfgang Meyerhof², Ingrid
Boekhoff¹

¹Walther-Straub-Institut, Pharmakologie & Toxikologie, AG Boekhoff, Goethestraße 33, 80336 Muenchen, Germany

² German Institute of Nutrition, Potsdam-Rehbrücke, Germany

³ Institute of Physiology, University Stuttgart-Hohenheim, Germany

⁴ University Hospital Hamburg-Eppendorf, Germany

During their transit through the female genital tract, sperm have to recognize and discriminate numerous chemical compounds. However, our current knowledge of the molecular identity of appropriate chemosensory receptor proteins in sperm is still rudimentary. Considering that members of the Tas1r family of taste receptors are able to discriminate between a broad diversity of hydrophilic chemosensory substances, the expression of taste receptors in mammalian spermatozoa was examined. Choosing complementary molecular, cellular and reproductive approaches we found that the two subunits of the umami taste receptor dimer (Tas1R1/Tas1R3) are expressed in mouse and human spermatozoa where their sub-cellular localization is restricted to distinct segments of the sperm flagellum and the acrosomal cap of the sperm head. Employing a Tas1r1-deficient mCherry reporter mouse strain, we found a significant increase in spontaneous acrosomal reaction in Tas1r1 null mutant sperm whereas acrosomal secretion triggered by isolated zona pellucida or the Ca²⁺ ionophore A23187 was not different from wild-type spermatozoa. Remarkably, cytosolic Ca²⁺ levels in freshly isolated Tas1r1-deficient sperm were significantly higher compared to wild-type cells. Moreover, a significantly higher basal cAMP concentration was detected in freshly isolated Tas1r1-deficient epididymal spermatozoa, whereas upon inhibition of phosphodiesterase or sperm capacitation, the amount of cAMP was not different between both genotypes. Since Ca²⁺ and cAMP control fundamental processes during the sequential process of fertilization, we propose that the identified taste receptors and coupled signaling cascades keep sperm in a chronically quiescent state until they arrive in the vicinity of the egg - either by constitutive receptor activity and/or by tonic receptor activation by gradients of diverse chemical compounds in different compartments of the female reproductive tract.

Deorphanization of members of the segregating pseudogenes of olfactory receptors

Kaveh Ashti Baghaei, Günter Gisselmann¹, Hanns Hatt¹

¹Ruhr-Universität Bochum/Cell physiology, Bochum, Germany

Olfactory receptors (ORs) family has evolved to detect a wide range of chemical structures but it exhibit extensive diversity within different human population. Widespread phenotypic diversity in human olfaction is, partly, related with genetic variation in OR genes. Such variations constitute natural knockout of specific ORs in some individuals, but not in others, potentially leading to phenotypic differences in olfactory acuity and perception. Segregating pseudogenes (SPGs) are known as genes that due to a disruptive single nucleotide polymorphism (SNP) segregate in populations between intact genes and pseudogenes. This divider mutation can introduce a stop codon, or alter a highly conserved amino acid that is important for proper function of the protein. Regarding to this point that specific anosmia is may arise from mutations in some olfactory receptor genes, we focused on ORs which are known as SPG and screened with odorants related to specific anosmia.

After HEK293 cells transfection with a collection of essential signal pathway proteins, Ca-imaging was used as main technique for deorphanization of olfactory receptor. We used different chemical structural odorants groups (ketones, aldehydes, alcohols, ambers and acids) for stimulation of several olfactory receptors.

With consecutive tests we found that ketone, aldehyde and amber group induced an elevation of Ca²⁺ in transfected cells with OR4X2, OR5L1 and OR2L8 respectively. In our study we found that these receptors as SPGs are activated by odorants in related to specific anosmia. Second step would be finding the role of single nucleotide polymorphism in phenotype variation by further genotypic studies.

Probing a potential heteromultimerization of recombinant anoctamin proteins

Tobias Ackels, Bastian Henkel², Eva Neuhaus², Marc Spehr¹

¹RWTH Aachen University, Dept. of Chemosensation, Institute of Biology II, Worringer Weg 1, 52074 Aachen, Germany

²CCO, Cluster of Excellence NeuroCure, Charité, Universitätsmedizin Berlin, 10117 Berlin, Germany

Calcium-activated chloride channels (CaCC) are abundantly expressed in different mammalian tissues such as epithelial, muscle or blood cells and various types of neurons. On the functional level, CaCCs are involved in epithelial secretion, membrane excitability and olfactory signal amplification.

In 2008, three groups independently identified a member of the anoctamin protein family (anoctamin 1 / TMEM16A) as a CaCC (Caputo et al, Schröder et al & Yang et al). More recent studies have then described anoctamin 2 / TMEM16B as the main carrier of the native calcium-activated chloride current in olfactory sensory neurons (Stephan et al, 2009; Pifferi et al, 2009; but see Billig et al, 2011).

Next generation sequencing reveals expression of anoctamins 1, 2 and 6 in the mouse olfactory epithelium.

Based on these pilot studies, we here analyze potential protein-protein interaction(s) of the three anoctamins expressed in olfactory tissue. First, individual channel subunits are recombinantly expressed in HEK293T cells, both with and without fluorescent tags. Whole cell patch-clamp recordings and calcium imaging experiments confirm the function of anoctamin 1 and anoctamin 2 as calcium-dependent chloride channels. Furthermore, we find that anoctamin 6 also forms a CaCC, albeit generating considerably smaller currents.

Next, using high-resolution fluorescence microscopy and bioluminescence resonance energy transfer (BRET) assays, we investigate coexpression and potential heteromultimerization of different anoctamin subunit combinations. Our preliminary results suggest that, in a heterologous expression system, recombinant anoctamins interact to form heteromultimeric complexes. On-going experiments now aim to characterize the functional effect(s) of these interactions.

References:

- Caputo et al, *Science*, 322, 590-594 (2008)
- Schröder et al, *Cell*, 134, 1019-1029 (2008)
- Yang et al, *Nature*, 455, 1210-1215 (2008)
- Pifferi et al, *Pflüger's Archive*, 458, 1023-1038 (2009)
- Stephan et al, *Cell*, 106, 11776-11781 (2009)
- Billig et al, *Nature Neuroscience*, 14, 763-769 (2011)

An *in vivo* Atlas of the *Drosophila* Antennal Lobe based on Receptor Neuron Targeting

Veit Grabe, Antonia Strutz¹, Bill S. Hansson¹, Silke Sachse¹

¹Max Planck Institute for Chemical Ecology, Department of Evolutionary Neuroethology, Hans-Knöll-Str. 8, 07745 Jena, Germany

One of the most important requirements for the analysis of *in vivo* imaging dataset is the availability of a 3D-atlas of the neuropil of interest, e.g. the antennal lobe (AL), which represents the first olfactory neuropil in insects. The most commonly used atlases for the AL in *Drosophila* have been generated under *in vitro* conditions. However, the application of these atlases to functional imaging data that have been obtained *in vivo* is limited: since the brain is dissected out of the head capsule followed by a cut of the antennal nerve, the neuropil shows major deformations due to the missing tension being produced by the nerve. We have therefore generated a fly expressing DsRed as a direct fusion with n-synaptobrevin (n-syb), a presynaptic SNARE protein, to label the neuropil *in vivo*.

By performing confocal scans of this line using our *in vivo* dissection method, we could reconstruct a 3D-model of the *in vivo* AL with the segmentation software AMIRA. To allow a reliable identification of glomeruli, we combined the DsRed:n-syb line with UAS-GCaMP 3.0 and GAL4 lines of specific olfactory receptors, including ORs and IRs, respectively. Hence we achieved a staining of particular glomeruli by their respective olfactory sensory neuron innervation in addition to the background staining of the neuropil. Our *in vivo* atlas comprises 53 glomeruli and is therefore an extension of the already published AL atlases. Moreover, we morphologically characterized the glomerular innervation patterns of broad GAL4 lines that we frequently use in our functional imaging studies, as the Orco- and GH146-GAL line, respectively. In addition we are quantifying the number of olfactory sensory neurons innervating each glomerulus to analyze any correlation between the volume of a glomerulus and the number of innervating neurons.

A model for sparse and reliable encoding of olfactory cues in the honeybee

Rinaldo Betkiewicz, Michael Schmuker^{1,2}, Farzad Farkhooi^{1,2}, Martin Paul Nawrot^{1,2}

¹Theoretical Neuroscience, Institute of Biology, Freie Universität Berlin, Germany

²Bernstein Center for Computational Neuroscience, Berlin, Germany

In their natural environment, animals sense and evaluate olfactory cues of time-varying composition and concentration. The olfactory pathways are specifically tailored to the physical reality of chemosensation and, interestingly, similar solutions have co-evolved in invertebrate and vertebrate nervous systems. Our goal is to explain how the insect olfactory system is optimized to reliably estimate the behaviorally relevant spatial and temporal aspects of a rich stimulus environment.

Here, we propose an approach to a realistic model of the honeybee olfactory system that demonstrates sparse and reliable stimulus encoding learning of olfactory stimuli. Specifically, we consider two fundamental processing features: structured lateral inhibition in the antennal lobe (AL) network (Schmuker et al., 2012) and cellular adaptation in successive processing layers (Nawrot 2012; see also poster by Nawrot & Farkhooi). Structured lateral inhibition in the AL improves the separability of odor stimuli, while the neuron-intrinsic mechanism of spike-frequency adaptation (SFA) shapes the stimulus response temporal dynamics. This effect of cellular adaptation becomes progressively pronounced at successive stages of the olfactory network, promoting temporal sparseness. Importantly, at the last stage, in the mushroom body, Kenyon cells (KCs) responses are highly reliable since SFA suppresses response variability (Farkhooi, Müller & Nawrot, 2011) and thus support the formation of stable associative memories (Strube-Bloss, Nawrot, & Menzel, 2011). In terms of a spatial odor code, only a few KCs are activated by a given odor (population sparseness; e.g. Honegger, Campbell & Turner, 2011). This sparse code facilitates the specific association of a stimulus with reward in a model study by Haenicke and colleagues (oral contribution to Symposium III: 13).

References

- Farkhooi F, Müller E, Nawrot MP. PRE 83: 050905, 2011
Honegger KS, Campbell RAA, Turner GC. J Neurosci 31: 11772-85
Nawrot MP. Apidologie 43:269-91, 2012
Schmuker M, Yamagata N, Nawrot MP, Menzel R. Frontiers Neuroeng 4: 17, 2011
Strauch M, Ditzen M, Galizia CG. Frontiers Systems Neurosci, 2012
Strube-Bloss M, Nawrot MP, Menzel R. J Neurosci 31:3129-40, 2011

Acknowledgements

We acknowledge generous funding by the German Ministry of Education and Research (BMBF) through grant 01GQ0941 to the project Insect Inspired Robots within the Bernstein Focus Learning and Memory (BFNL) program. R.B. is supported through the Research Training Group Sensory Computation in Neural Systems (GRK 1589) funded by the German Research Foundation (DFG).

Gene expression profiling and the olfactory sense of ***Manduca sexta***

Christopher Koenig, Sascha Bucks¹, Monika Stengl², Heiko Vogel³, Ewald Grosse-Wilde¹, Bill S Hansson*¹

¹Max Planck Institute for Chemical Ecology, Evolutionary Neuroethology, Hans Knoell Strasse 8, 07745 Jena, Germany

²University of Kassel, Animal Physiology, Moenchebergstraße 19, 34109 Kassel, Germany

³Max Planck Institute for Chemical Ecology, Entomology, Hans Knoell Strasse 8, 07745 Jena, Germany

Manduca sexta has become a model organism in neuroscience over the last 4 decades. Analysis of its olfactory sense recently has seen an upsurge in importance due to its natural behavior in the context of ecology. While the species has been well described regarding physiology of antenna and CNS as well as behavior. A focus has been olfaction in the context of mating, oviposition and foraging. However, the underlying genetic network is still poorly understood. Here we report the use of the recently published genome data of *Manduca sexta* in the identification of olfactory (ORs) and ionotropic receptors (IRs). IRs and ORs are the two main receptor families acting as key elements of olfaction. We analyse the *M. sexta* specific receptor types in the context of general insect ORs/IRs. Furthermore, we characterise the expression of the receptors in several tissues as well as developmental stages. The presented data will serve as a basis for future expression analysis of olfactory genes, focusing on epigenetic effects elicited by changes in the animals lifecycle (e.g. age, mating status) or physiological state (e.g. daytime) and acting on both olfactory genes and regulatory networks.

This study was supported by the Max Planck Society.

Effects of adiponectin on the olfactory system

Diana Loch, Heinz Breer¹, Jörg Strotmann¹

¹University of Hohenheim, Institute of Physiology, Garbenstraße 30, 70599 Stuttgart, Germany

The intake of food is controlled by specialized brain centers and modulated via various endocrine signals. In addition, sensory, in particular chemosensory information from the gustatory and olfactory systems is an important factor for appreciating the palatability of food and strongly influence the eating behaviour. The notion for a possible interplay between endocrine and chemosensory systems is supported by recent studies demonstrating that receptors for several hormones are expressed in the olfactory epithelium (OE). Of particular interest was the finding that a distinct receptor type for the hormone adiponectin is expressed. Adiponectin is a peptide hormone produced and secreted by adipose tissue when the concentration of stored fat reserves is very low; adiponectin is transmitting a starvation signal. The idea that a signal indicating a seriously low level of energy reserves could modulate the olfactory system is of particular interest; it is conceivable that it might increase the responsiveness of the sense of smell and thus increase the probability for finding a food source. The fact that the adiponectin receptor subtype *adipoR1* is expressed in mature sensory neurons of the OE has lead us to hypothesize that adiponectin may affect the reactivity of olfactory sensory neurons. In order to monitor the responsiveness of olfactory neurons, we have used *Egr1* expression as an indicator for cell activation. After odorant exposure we determined the number of activated cells on a representative turbinate structure. In a first approach mice were set under caloric restriction to increase blood adiponectin levels. Comparing the number of odor-activated cells between caloric restricted (CR) and control (CO) mice revealed a higher number of *Egr1*-positive cells in CR mice. These results indicate that caloric restriction caused a change in the responsiveness of olfactory sensory neurons. To scrutinize the hypothesis that these changes may at least partially be due to an elevated blood level of adiponectin, we have investigated the effect by a nasal application of adiponectin. This method is currently often used to deliver drugs and other agents via nasal passage directly to the brain. After nasal application of adiponectin followed by an incubation for 30 minutes, mice were exposed to an odorant and the number of *Egr1*-positive cells determined. In adiponectin-treated mice the number was significantly higher than in mice treated with buffer solution. The same results were found for other turbinate structures or different odorants. To analyze if the effect at the level of the OE was reflected in higher activity in the olfactory bulb, we have studied transgenic MOR256-17-IRES-tau-GFP mice. After pretreatment with adiponectin, mice were exposed to 2,3-hexanedione, a ligand for the receptor MOR256-17. After identifying the appropriate glomeruli in the OB by GFP-fluorescence, we have counted the number of activated interneurons surrounding the glomeruli using anti *cFos* immunohistochemistry. It was found that in adiponectin-treated mice the number of activated interneurons was increased. In summary our results support the notion that adiponectin increases the responsiveness, probably the sensitivity of olfactory sensory neurons. The activation of more olfactory sensory neurons after adiponectin treatment is also reflected in a stronger activity in the OB.

This work was supported by the Deutsche Forschungsgemeinschaft.

FMRFamide-immunostaining reveals SIFamide in the antennal lobe of the honeybee

Sabine Kreissl, Anne Schapals¹, Giovanni C. Galizia¹

¹University of Konstanz, Biology, M624, 78457 Konstanz, Germany

A variety of transmitters and neuropeptides have been identified in the primary olfactory neuropile, the antennal lobe of the honeybee, but many remain to be characterized. Previous immunohistochemistry research has shown that fine neurites in the periphery of glomeruli in the antennal lobe are immunoreactive for the neuropeptide FMRFamide (Schürmann and Erber, 1990), however the precise peptide sequence FMRFamide for which the antiserum was raised does not exist in the honeybee. Since FMRFamide related peptides sharing a c-terminal RFamide (FaRPs) are present in the brain (Boerjan et al., 2010), the FMRFamide-staining may represent an inclusive pattern due to an expected cross-reaction of the antiserum with FaRPs of the honeybee.

We have previously localized the FaRPs Sulfakinin and Myosuppressin in other parts of the brain but not in the antennal lobes. Conversely, we observed a striking similarity between the shape and localization of a subset of FMRFamide-immunoreactive neurites and SIFamide-immunoreactive neurites in the antennal lobes. Moreover, seven FMRF-like Peptides (FLPs) from eyestalks of the giant tiger prawn have been identified by using an antiserum against FMRFamide. Among them was SIFamide, originally named FLP7 (Sithigorngul et al., 2002), although it only shares the c-terminal amidated F (phenylalanine) and is commonly not considered as a FaRP. SIFamide therefore exhibits sufficient structural similarity to be detected by antisera against FMRFamide.

Here, we test the hypothesis that the staining pattern obtained with antisera against FMRFamide in the antennal lobe of the honeybee reveals the localization of SIFamide. We performed double labeling with antisera against both peptides and appropriate preadsorption controls. We show that FMRFamide-staining in the periphery of glomeruli is due to SIFamide containing neurites, confirming the hypothesis.

References:

- Boerjan B, Cardoen D, Bogaerts A, Landuyt B, Schoofs L, Verleyen P. 2010. Mass spectrometric profiling of (neuro)-peptides in the worker honeybee, *Apis mellifera*. *Neuropharmacology* 58:248-258.
- Schürmann FW, Erber J. 1990. FMRFamide-like immunoreactivity in the brain of the honeybee (*Apis mellifera*). A light- and electron microscopic study. *Neuroscience* 38:797-807.
- Sithigorngul P, Pupuem J, Krungkasem C, Longyant S, Chaivisuthangkura P, Sithigorngul W, Petsom A. 2002. Seven novel FMRFamide-like neuropeptide sequences from the eyestalk of the giant tiger prawn *Penaeus monodon*. *Comparative Biochemistry and Physiology B: Comparative Biochemistry and Molecular Biology* 131:325-337.

Post-stimulus activity in the olfactory pathway of *Drosophila*

Alja Lüdke, Kristina Dylla¹, C. Giovanni Galizia¹, Paul Szyszka¹

¹University of Konstanz, Neurobiology, 78457 Konstanz, Germany

In classical conditioning, animals learn to associate a neutral stimulus (CS) with a reinforcing stimulus (US). Classical conditioning is effective both when CS and US are overlapping in time (delay conditioning) or when there is a temporal gap between the stimuli (trace conditioning). In order to associate non-overlapping stimuli in trace conditioning the sensory systems must keep a neural representation of the first stimulus after its termination (i.e. a stimulus trace). *Drosophila* and other insects are able to solve the olfactory trace conditioning task. However, the neural substrate of the underlying odor trace is not known. To address this issue, we investigated whether and how olfactory information is kept after odor offset along the olfactory pathway of *Drosophila*. Using *in vivo* calcium imaging and the GAL4/UAS system, with OR83b/Orco, GH146 and MB247 as driver lines, we measured odor evoked activity in three consecutive processing stages: in olfactory receptor neurons and projection neurons of the antennal lobe, and in Kenyon cells of the mushroom body. We analyzed the spatio-temporal response patterns of odor responses and post-odor responses in glomeruli, which are the functional units of the antennal lobe. In both, receptor neurons and projection neurons odors evoked specific response patterns of activated and inhibited glomeruli, which corresponded to the previously described combinatorial response patterns (see <http://neuro.uni.kn/DoOR>). After odor offset, the odor response patterns turned into prolonged post-odor response patterns of activated and inhibited glomeruli, which were dissimilar to the initial odor response patterns, but still odor specific. Variation of the stimulus length had only minor effects on the post-odor activity patterns. Taken together, these results show that there is a physiological odor trace in the antennal lobe of *Drosophila*. Whether this physiological trace is the substrate of the behavioral trace remains to be determined.

The neglected sense - Olfactory Communication in a songbird, the Zebra Finch (*Taeniopygia guttata*)

E. Tobias Krause, Barbara A. Caspers¹

¹University of Bielefeld, Department of Animal Behaviour, Morgenbreede 45, 33615 Bielefeld, Germany

Although it has long been thought that birds have a poor sense of olfaction, avian olfaction has recently become an expanding area of interest. Songbirds, especially males, are primarily known for their acoustic abilities as they use song to attract females and/or to deter male competitors. Intraspecific communication in many songbird species is also achieved through visual signals, such as colourful plumage traits or nest constructions that attract females with their exaggerated architecture and decoration. The idea that olfactory signals might also play an important role in intraspecific communication in songbirds thus seems to be unlikely at first sight, for several reasons. I) Songbirds have small olfactory bulbs. II) Visual and acoustic signals are known to play such significant roles in songbird behaviours and III) songbirds do not use an obvious odour guided behaviour (i.e. sniffing). Thus, it could be questioned which additional information might be communicated by olfactory signals.

However, in recent studies [1-3], we demonstrated that zebra finches (*Taeniopygia guttata*), a widespread avian model organism, do not only have a sense of smell, but that they use olfactory cues for orientation and also for social communication, such as kin recognition. Olfactory cues might thus indeed encode potential additional information apart from visual and acoustic cues.

References:

1. Caspers BA, Krause ET (2011) Odour-based natal nest recognition in the zebra finch (*Taeniopygia guttata*), a colony-breeding songbird. *Biology Letters* 7: 184-186
2. Krause ET, Krüger O, Kohlmeier P, Caspers BA (2012) Olfactory kin recognition in a songbird. *Biology Letters* 8:327-329
3. Krause ET, Caspers BA (2012) Are olfactory cues involved in nest recognition in two social species of estrildid finches?. *PLoS One* 7: e36615

SPLITGFP - MEDIATED LOCALIZATION OF CONNECTIVITIES BETWEEN INTRINSIC AND EXTRINSIC MUSHROOM BODY NEURONS IN **DROSOPHILA**

Ulrike Pech, Atefeh Pooryasin¹, Serge Birman², André Fiala¹

¹Georg-August-University of Goettingen, Molecular Neurobiology of Behavior, Julia-Lermontowa-Weg 3, 37077 Goettingen, Germany

²Laboratoire de Neurobiologie, ESPCI Paris-Tech, CNRS, 10, rue Vauquelin, 75005 Paris, France

The *Drosophila* mushroom body has been anatomically thoroughly described, and a functional subdivision of anatomically distinct mushroom body regions has been characterized. The modulation of the mushroom body intrinsic Kenyon cells by biogenic amines is known to play a crucial role for adaptive behaviors, e.g. olfactory learning and sleep. We asked which parts of the mushroom bodies are anatomically connected to specific aminergic, modulatory neurons.

For that purpose, we used the recently introduced tool “GFP reconstitution among synaptic partners, GRASP” (Feinberg et al., *Neuron* 2008;57:353-63) and generated a fly that expresses one part of a split GFP under control of the mushroom body specific promoter mb247. The second part of the split GFP is expressed under UAS control, which allowed us to readily visualize the connectivity between mushroom body intrinsic and mushroom body extrinsic neurons. Here, we used this technique to determine regions of connectivity between Kenyon cells and dopaminergic, serotonergic and octopaminergic neurons. This reveals spatially and structurally different connectivities between the three neuromodulatory type of neurons and Kenyon cells in different subdivisions of mushroom body, as well as spatially distinct zones of interconnectivities between Kenyon cells and aminergic neurons within subdivisions.

Our approach facilitates the characterization of connectivity between Kenyon cells and mushroom body extrinsic neurons, both *in vivo* and in stained brains, and also allows for the independent manipulation of additional neurons, e.g. through the LexA system. Therefore, it might provide a useful tool for the *Drosophila* research community.

Comparative neuroanatomical study of the antennal lobes of hornets.

Antoine Couto, Karine Monceau², Olivier Bonnard², Denis Thiéry², Jean-Christophe Sandoz¹

¹CNRS, LEGS, 1 Avenue de la terrasse, 91190 Gif-sur-Yvette, France

²INRA, UMR 1065 Save, ISVV, 71 Ave E. Boulreaux, F33883 Villenave d'Ornon Cedex

Hornets are eusocial insects belonging to the Vespidae family among Hymenoptera. The genus *Vespa* comprises 22 species which are widely spread on the Eurasian continent. To feed their larvae with proteins, hornets prey on numerous insect species. However, in different biotopes feeding resource change, exerting a strong selective pressure on predatory behavior. Hornets therefore display various types of predatory behaviors, ranging from en masse predation (e.g. *Vespa mandarinia*), in which scouts actively recruit nestmates to attack for instance honeybee colonies, to solitary hunters (e.g. *Vespa crabro*), with intermediate cases of cooperative predation among nestmates (e.g. *Vespa velutina*). Honey bees represent a major food source in some Asian hornet species. Having coevolved with such hornets, asian honey bees (*Apis cerana*) have developed effective defensive strategies, such as "heat balling", in which hornet scouts are heated to death by accumulating groups of honeybee workers. In western Europe, only one hornet species was present, *Vespa crabro*, which never represented a strong threat for honeybee colonies, due to its solitary hunting strategy. Recent invasion by the Asian hornet, *Vespa velutina*, in France has shown that European bees *Apis mellifera* are not able to protect their colonies from the cooperative predation strategy of this hornet. For this reason, hornet predation has become a major problem in France and methods for limiting hornet populations are currently looked for. Olfaction plays a key role in the biology and predatory behavior of hornets. One promising strategy for controlling hornets would be to interfere with their olfactory behavior using specific olfactory baits. We are therefore interested in whether the olfactory system of *Vespa velutina* presents specializations underlying its cooperative hunting behavior. In insects, odorant molecules are detected by olfactory sensory neurons (OSN) on the antennae, which project to a primary olfactory structure, the antennal lobe. This structure is made of morphologic and functional units called 'glomeruli' which each gather input from a given type of OSN. In males but also in workers of some insect species, enlarged glomeruli called 'macroglomeruli' are involved in the detection and processing of pheromonal signals. In particular, in the workers of leaf-cutting ants (*Atta* and *Acromyrmex*), a macroglomerulus responding to trail pheromone is involved in foraging behavior. Finding macroglomeruli in hornets may indicate the use by workers of chemical signals and the existence of the suspected foraging site-marking pheromone. As a first step in this direction, we used anterograde antennal staining of OSNs, confocal microscopy and 3D reconstruction to compare the architecture of the antennal lobes of each caste of two hornet species, *Vespa velutina* a cooperative hunter and *Vespa crabro*, a solitary hunter. This neuroanatomical study is the first step towards understanding intraspecific communication in hornets and its evolution. Using an integrative approach combining neuroanatomy, functional imaging and chemical ecology, we aim to identify possible chemical signals involved in the predatory behavior of hornets.

Pheromonal sex communication in honeybee drones: from odor processing to orientation behavior

Andreas S. Brandstaetter, Florian Bastin¹, Jean-Christophe Sandoz¹

¹CNRS Gif-sur-Yvette, Laboratoire Évolution, Génomes et Spéciation (LEGS), Avenue de la Terrasse, Bât 13, 91198 Gif-sur-Yvette, France

Honeybees, *Apis mellifera*, are a main-stream animal model for the study of ethology, neurobiology, and animal cognition. Yet, for all the knowledge acquired on this model organism, crucial aspects of its reproductive behavior still remain elusive. During the mating season, several thousand male honeybees, the drones, gather in drone congregation areas (DCA) 10-40 m above ground. When a receptive female, a virgin queen, enters the DCA, drones are attracted to her first by olfactory cues (pheromones) and on shorter range by visual cues. Drones compete for the queen in flight, scrambling for a good position to approach her and mate. Within 15-30 minutes the queen mates in mid-air with typically 10-20 drones, who die after copulation.

It is not fully understood yet, how drones and virgin queens find the DCAs; distal visual cues on the horizon are most probably important but the possible existence of drone-produced aggregation pheromones has been proposed, but was never demonstrated. We investigated innate odor preferences of drones under controlled laboratory conditions using a walking simulator based on a locomotion compensator. First, we tested behavioral responses of drones to 9-oxo-2-decenoic acid (9-ODA), the major sexual attractant produced by queens, and to queen mandibular pheromone (QMP), an artificial blend of 9-ODA and several other queen-derived components. QMP is known to be an important social regulator of queen-worker interaction. While 9-ODA resembles the odor bouquet of virgin queens in which this queen-specific component is most abundant, QMP (9-ODA + other components) rather resembles the odor bouquet of a mated queen. A differential behavioral response to 9-ODA and QMP could, thus, be adaptive. It would indicate that drones process sex pheromones in a combinatorial manner, i.e. the perception of the main component is influenced by the presence of other queen-derived components. In our behavioral assay, drones were indeed attracted by 9-ODA, but did not show any attraction to QMP. Next, we investigated the potential attractivity of male-derived odors, which may be involved in the formation of DCAs. We tested drones' behavioral responses to the odor bouquet of groups of living drones or workers in the walking simulator. Our results demonstrate for the first time that honeybee drones are attracted by groups of other drones but are not attracted by the same number of workers.

Drones are an organism specially adapted for mating and their olfactory system is tuned for sex communication. The antennal lobe (AL), the primary olfactory center of the insect brain, features 4 hypertrophied functional units in drones, the macroglomeruli. Recently, the largest macroglomerulus MG2 has been shown to respond specifically to 9-ODA. Behavioral experiments on free-flying drones and in our walking simulator suggest a combinatorial processing of 9-ODA and other queen-derived components. It is neither known how odors involved in sex communication are processed in the AL of drones nor to which odors the 3 remaining macroglomeruli respond to. Using in-vivo calcium imaging, we studied neuronal responses of AL output neurons to a wide panel of honeybee pheromones. Comparing our output data with results from an earlier study on the AL input will help us understanding how the drone olfactory system processes odors that are crucial for sex communication and mating.

Activity Dependent Plasticity in the Olfactory System of Adult *Tribolium castaneum*

Peter Christ, Martin Kollmann¹, Joachim Schachtner¹

¹Philipps-University Marburg, Dept. Biology, Animal Physiology, Karl-von-Frisch Str. 8, 35043 Marburg, Germany

Tribolium castaneum is an excellent model to study development and plasticity of the olfactory system. A previous work on volume of distinct neuropils revealed a pronounced increase of brain volume including antennal lobes (AL) and mushroom bodies (MBs) within the first days of adult life, indicating a pronounced sensitive phase. To further reveal this mechanism, we examined neuropeptides possibly involved in this postmetamorphic plasticity. We compared the numbers of tachykinin-immunoreactive (TK-ir) AL neurons of females and males directly (A0) and seven days after adult eclosion (A7). We found a sexual dimorphism at A0 concerning numbers of TK-ir cells, with females having more TK-ir AL neurons than males. In both sexes, the numbers of AL TK-ir cells increased from A0 to A7. Females, isolated shortly before adult eclosion and rose to A7, showed no increase in the number of TK-ir cells, in contrast to males held under same conditions. As in *T. castaneum* males are the main source of pheromone, we concluded, increase in TK-ir cell number can be induced by perception of odors. To extend these findings, we added the pheromone 4,8 Dimethyldecanal (DMD), the food-related odor leaf alcohol (cis-3-Hexen-1-ol) or the insect repellent (DEET) to isolated beetles. Further we used the RNAi technique to impair odor perception. The pheromone as well as the food related odor led to an increase in number of TK-ir cells in both sexes, while DEET addition and impaired odor perception prevented an increase in cell number. These results suggest that the increase of TK-ir cells between A0 and A7 depends on the perception of olfactory signals and favors an activity dependent mechanism for the maturation of a peptidergic system in the AL of the red flour beetle.

- Supported by the DFG priority program SPP 1392 “Integrative Analysis of Olfaction“ (SCHA 678/13-1)

Inhibitory projection neurons bias odor attraction behavior in the lateral horn area of *Drosophila melanogaster*

Antonia Strutz, Jan Soelter², Amelie Baschwitz¹, Veit Grabe¹, Farhan Abu¹, Jürgen Rybak¹, Markus Knaden¹, Michael Schmucker^{2,3}, Bill S. Hansson¹, Silke Sachse¹

¹Max Planck Institute for Chemical Ecology, Evolutionary Neuroethology, Hans-Knoell-Str. 8, 07745 Jena, Germany

²Free University Berlin, Dept. of Neuroinformatics & Theoretical Neuroscience, Berlin, Germany

³Bernstein Center for Computational Neuroscience, Berlin, Germany

The well investigated olfactory system of the vinegar fly *Drosophila melanogaster* enables a deep insight into neuronal coding within chemosensory networks. Projection neurons (PNs) depict the second order neurons of the olfactory system, relaying olfactory information from the primary olfactory neuropil, the antennal lobe (AL), to higher brain areas: the mushroom body calyx (MBC) and the lateral horn (LH). Studies of uniglomerular excitatory PNs (ePNs), which target both higher brain centers, helped to assign a role of the MBC in olfactory learning processes. A role in innate olfactory behavior is assumed for the LH, but could not have been shown so far.

Inhibitory PNs (iPNs) have multiglomerular innervations in the AL and target the LH exclusively. By studying this poorly investigated neuronal population we shed light on its function as well as its role for olfactory coding in the LH area.

Vibratome-immunostainings with pre- and postsynaptic markers detect a dense cholinergic input via OSNs to iPNs in AL, whereas the LH area comprises their main output site. Thus the neuronal polarity is directed from the first olfactory neuropil to the higher brain center (comparable to the ePN population).

Silencing GABA expression in iPNs via RNAi leads to drastic changes in hedonic valences of odors resulting in a decreased attraction to attractive odors and enhanced avoidance to repulsive odors. This result strongly suggests that GABA release of iPNs in the LH mediates odor attraction behavior.

To physiologically characterize iPNs we performed functional imaging with a large set of ecologically relevant odors at different concentrations. The cholinergic glomerular input in the AL was determined via calcium imaging of presynaptic olfactory sensory neurons as well as reconstructed single iPN neurites labeled by photoactivated GFP (paGFP). The functional iPN-output in the LH was analyzed using spatial independent component analysis. The algorithm extracts three main odor response domains in the LH. Activity in these domains clearly correlates with the hedonic valence of odors, independent of odor intensity. Three-dimensional maps of reconstructed paGFP labeled iPNs show that the cellular substrate for these domains is provided by selective neuronal innervations of specific iPNs.

Our results show that inhibitory odor coding in the LH is highly stereotyped and correlates with the hedonic valence of odors independent of their intensity. Moreover we found that iPNs play a crucial role for evaluating pleasantness of ecologically important odors.

The olfactory pathway of the red flour beetle *Tribolium castaneum*

Martin Kollmann, Stefan Dippel^{2,3}, Sergius Frank¹, Stephanie Crombach¹, Stefan Schütz³, Ernst A. Wimmer², Joachim Schachtner¹

¹Philipps-Universität Marburg, Animal Physiology, Karl-von-Frisch-Straße 8, D-35043 Marburg, Germany

²Georg-August-University Göttingen, Dept .of Developmental Biology, Johann-Friedrich-Blumenbach-Institute of Zoology and Anthropology, Julia-Lermontowa-Weg 3, D-37077 Göttingen

³Georg-August-University Göttingen, Institute for Forest Zoology and Forest Conservation, Buesgenweg 3, 37077, D-Göttingen

The olfactory pathway of *Tribolium castaneum*, as well as of most other insects, starts with the olfactory sensory neurons (OSNs) in the chemoreceptor sensilla of the antenna, which project into the glomeruli of the antennal lobe (AL). From the AL projection neurons send their axons in higher olfactory integration centers, the mushroom body (MB) and the lateral protocerebrum / lateral horn. By creating a Gal4-UAS line, expressing tGFP in all ORNs, which contain the ORCO (the general olfactory receptor), using an antibody against ORCO, electron raster microscopy of the antenna, immunostainings of the brain und backfills of the antenna and maxillary palps, we characterize the olfactory pathway of the red flour beetle *Tribolium castaneum* in high detail. Analyzing the anatomical features of the pathway revealed no sexual dimorphism at the level of the antenna and the AL. Interestingly, backfills from the antenna not only label olfactory glomeruli but additionally suggest a connection with the accessory medulla of the optical lobes, which serves as circadian clock in the insect brain. Backfills of the maxillary palps resulted in only one glomerulus in the AL.

Supported by the DFG priority program SPP 1392 'Integrative analysis of olfaction' (SCHU 1135/13-1, WI 1797/4-1, SCHA 678/13-1)

Key Players – Functional analysis of *Manduca sexta* Olfactory Receptors

Christian Klinner, Christopher König¹, Shannon Olsson¹, Marcus C. Stensmyr¹, Bill S. Hansson¹, Ewald Grosse-Wilde¹

¹Max Planck Institute for Chemical Ecology, Department of Evolutionary Neuroethology, Hans-Knöll-Straße 8, D-07745 Jena, Germany

The tobacco hornworm *Manduca sexta* is a main model of olfactory research in general as well as in the context of ecology. The key to understand and manipulate the olfactory sense at a molecular level are olfactory receptors (ORs). ORs interact specifically with volatile odor molecules and determine the ligand specificity of distinct neurons. To connect physiology and behaviour to OR function analysis of these proteins is necessary. To address this issue we employ the „empty neuron“ technique using *Drosophila melanogaster*; this technique was demonstrated as useful for testing/ deorphaning of ORs allowing rapid de-orphanization (Hallem et al. 2004; Syed et al. 2006; Carey et al. 2010). We have created fly lines expressing OR coding genes from *M.sexata*; in electrophysiological recordings we have assessed the ligand profile of each MsexOR, enabling us to predict possible behavioural functions. Here we present the first data from a large-scale deorphaning of non-pheromone sensitive ORs of a non-dipteran species using the “empty neuron” system of *Drosophila melanogaster* as heterologous expression system for functionally characterization. This project was funded by the Max-Planck Society.

Olfaction in the jumping bristletail *Lepismachilis y-signata* (Archaeognatha, Machilidae)

Christine Mißbach, Hany Dweck¹, Steffen Harzsch², Marcus C. Stensmyr¹, Markus Knaden¹, Bill S. Hansson¹, Ewald Grosse-Wilde¹

¹Max Planck Institute for Chemical Ecology, Evolutionary Neuroethology, Hans-Knöll-Straße 8, 07745 Jena, Germany

²Ernst Moritz Arndt Universität Greifswald, Cytologie und Evolutionsbiologie, Johann Sebastian Bach Straße 11/12, 17487 Greifswald, Germany

To learn more about the evolution of the insect olfactory system it is important to investigate insect taxa that represent the base of insect evolution, like the Archaeognatha. Archaeognatha or jumping bristletails are hypothesized to be the sister group of all other insects, supported by morphological as well as molecular data. Archaeognatha or jumping bristletails are primary wingless insects that evolved approximately 390 million years ago. We are addressing the questions: Does this insect group possess a functional olfactory system and how is the system organized. Is it simpler than the olfactory systems of higher insects?

Using electrophysiological, morphological and molecular techniques have demonstrated that *Lepismachilis y-signata* possesses an acute but simple olfactory system, displaying a unique morphological and molecular makeup among extant insects. On the antennae only five different functional types of olfactory sensilla basiconica are present, responding to a broad spectrum of odors, including acids, aldehydes, alcohols, but also ketons and esters. Nine out of twelve identified neurons respond to at least one of the tested odors. The neurons express ionotropic receptors (IR), a group of ionotropic glutamate receptors, recently shown to be involved in olfaction across Protostomia. No insect olfactory receptors (ORs) and no olfactory coreceptor (ORCo) were detected in an antennal and maxillary palp transcriptome, suggesting that the IRs are the ancient olfactory receptor type in insects. The OSNs innervate a glomerular antennal lobe that only possesses a few irregularly shaped, elongated glomeruli. Olfactory information is further processed in the lateral Protocerebrum. Mushroom bodies that are supposed to be involved in learning and memory, but also integration of different sensory modalities, like vision and olfaction are completely absent in Archaeognatha. To investigate the olfactory behavior of *L. y-signata* putative food sources were tested in a four-choice olfactometer. We could demonstrate that *L. y-signata* is attracted by the blend of old decomposing leaves of field maple, *Acer campestre*, whereas moss showed no attraction. In GC-SSR recordings we could show that moss as well as the maple leaves can be perceived by the animals. The animals are able to discriminate between those two sources. Altogether we argue that *L. y-signata* has an olfactory system that appears to be far more simple in many aspects for example in the number of sensillum types, neuron and glomeruli numbers, as well as the receptors that are involved, however it is perfectly adapted to its environment, from the antennae to the brain to behavior.

L. y-signata presents the unique opportunity to analyze a minimalized insect olfactory system.

This study was supported by the Max-Planck-Society and the International Max Planck Research School.

The neuropeptidome of *Tribolium castaneum* antennal lobes and mushroom bodies

Marlene Binzer, Carsten M. Heuer¹, Jörg Kahnt², Joachim Schachtner¹

¹Philipps Universität Marburg, Dept. Biology, Animal Physiology, Karl-von-Frisch-Straße 8, 35043 Marburg, Germany

²Max Planck Institut für Terrestrische Mikrobiologie, 35043 Marburg, Germany

Among the signaling molecules involved in neuronal communication, neuropeptides represent the largest and most diverse group. They are able to shape the activity pattern of neuronal circuits and are thus accepted to be of major importance for the functional condition and output pattern of the central nervous system. Furthermore, neuropeptides are thought to be involved in processes related to neuronal plasticity, the substrate for learning and memory.

In the presented project we aim to characterize the neuropeptide repertoire of two integrative neuropils in the olfactory pathway of the red flour beetle *Tribolium castaneum*, the antennal lobes (ALs) and the mushroom bodies (MBs). The ALs act as primary olfactory centers that receive direct input from olfactory receptor neurons and are involved in early processing and modification of olfactory signals. They are intimately linked to higher integrative brain centers such as the MBs, which also receive information from other sensory modalities.

To further reveal the principal repertoire and the potential role of neuropeptides in the AL and the MB, these neuropils were investigated by two complementary methods. To assess the full range of the AL and MB neuropeptidome, isolated tissue samples of these brain centers were subjected to MALDI-TOF mass spectrometry by direct peptide profiling. Immunohistochemical stainings allowed us to confirm the presence of neuropeptide transmitters and to localize sites of expression in the ALs and MBs of *T. castaneum*. In another approach, we examine postmetamorphic changes in the neuropeptide repertoire of AL and MB. To quantify those changes we use stable isotope-labeled peptide analogues as internal standards.

Supported by the DFG priority program SPP 1392 "Integrative analysis of olfaction" (SCHA 678/13-1)

Coding of floral and pheromonal odors by two olfactory subsystems in the honeybee brain

Jean-Christophe Sandoz, Julie Carcaud^{1,2}, Martin Giurfa²

¹CNRS, Evolution Genomes Speciation Lab, Gif-sur-Yvette, France

²Paul Sabatier University & CNRS, Research Center for Animal Cognition, Toulouse, France

Sensory systems use parallel processing to extract and process different features of environmental stimuli. Parallel processing has been studied in the auditory, visual and somatosensory systems, but research in the olfactory modality has shown little progress. An invertebrate model like the honeybee is well-suited for such research, as it provides relative neuronal simplicity with good experimental access to the brain and robust behavioural paradigms. Strikingly, the honey bee brain contains a dual olfactory system, with a clear dichotomy from the periphery up to higher-order centres, subtended by two main neuronal tracts (median and lateral Antenno-Protocerebral Tract, m-APT and l-APT). The function of this dual system is still unclear, and different attributes of odour quality may be differentially encoded in these subsystems. We have thus started a thorough functional study of olfactory coding in both subsystems, using *in vivo* calcium imaging to reveal neuronal activity. As one of the subsystems (m-APT) has never been imaged before, a novel imaging preparation was developed to access the glomeruli belonging to it. Using this preparation as well as the conventional preparation for imaging l-APT glomeruli, we compared the responses of both subsystems to floral and pheromonal odorants at different concentrations. Our data show a general redundancy of olfactory coding for aliphatic odorants in the two subsystems, with some differences in the coding of carbon chain length information. More striking differences between the two subsystems appeared however in their responses to queen, brood and worker pheromones, as many of these pheromones are processed by one but not the other subsystem. Our current experiments aim to understand neural processing at higher levels of both pathways.

Synaptic circuitry of identified neurons in the antennal lobe of *Drosophila melanogaster*

Jürgen Rybak, Giovanni Talarico³, Santiago Ruiz², Christopher Arnold¹, David Neubert¹, Rafael Cantera², Bill Hansson¹

¹Max Planck Institute for Chemical Ecology, Department of Evolutionary Neuroethology, Hans-Knoell-Str. 8, 07745 Jena, Germany

²Instituto de Investigaciones Biológicas Clemente Estable, Montevideo, Uruguay

³Universitätsmedizin Greifswald, Institute for Legal Medicine, Greifswald, Germany

Olfactory cues in *Drosophila melanogaster* are processed in multiple microcircuits in the first olfactory relay station of CNS, the antennal lobe (AL). The glomerular synaptic network is principally comprised of receptor neurons, local interneurons and projection neurons. In a correlative LM-EM analysis we are dissecting this circuitry by combining confocal microscopy, 3D models and reconstructions of serial electron microscopy (EM) sectioning.

Genetic labeling AL output neurons (projection neurons, PNs) were labeled using a genetically encoded membrane-bound EM marker: Horseradish peroxidase: HRP::CD2 (Watts et.al. 2004) driven by the GAL4-line GH146. This made possible to trace and reconstruct with high reliability synaptic sites in PNs. 3D model In order to identify individual glomeruli (VA7, DM2, and DL5) of the AL at the EM level, landmark structures were segmented from panoramic EM views of the complete AL. This 3D model was then registered to a template glomerular AL map (nomenclature: Laissue et al. 1999) derived from confocal images of GH146-Gal4 immuno-stained specimen co-stained with the synaptic marker nc82-Cy2. Identification of PN synapses We have found PN input and output synapses, with characteristic T-shaped densities, consisting of platform and pedestal, as well as synapses between PN profiles. A common synaptic constellation was a tetrad, i.e. a presynaptic profile, opposed to four postsynaptic profiles containing postsynaptic densities. A conspicuous synaptic feature, found in PNs and yet unidentified, presumably local interneuron processes, is the presence of T-bars with an elongated platform and several pedestals forming multiple connection to up to 5-6 postsynaptic processes, including PN profiles. Outlook Currently, we are extending our analysis of AL synaptic circuitry to include receptor neurons and local interneurons.

Laissue et.al (1999) Three-dimensional reconstruction of the antennal lobe in *Drosophila melanogaster*. J comp Neurol 405(4). Watts et.al (2004) Glia engulf degenerating axons during developmental axon pruning. Curr Biol 14(8)

Bimodal processing of olfactory information in an amphibian nose: Odor responses segregate into a medial and a lateral stream

Sebastian Gliem, Adnan S. Syed^{2,3}, Alfredo Sansone¹, Eugen Kludt¹, Evangelia Tantalaki¹, Sigrun I. Korsching^{3,5}, Ivan Manzini^{1,4,5}

¹University of Göttingen, Dept. of Neurophysiology and Cellular Biophysics, Humboldtallee 23, 37073 Göttingen, Germany

²Shared first author

³Department of Genetics, University of Cologne, Zùlpicher Strasse 47a, 50674 Köln, Germany

⁴DFG Research Center for Molecular Physiology of the Brain (CMPB), University of Göttingen, Humboldtallee 23, 37073 Göttingen, Germany

⁵Shared senior author

Several spatially segregated subsystems define the mammalian olfactory system, in contrast to the single sensory surface present in fish. This difference in organization might be related to the transition from aquatic to airborne olfaction between fish and landliving tetrapods, which presumably has necessitated a major rebuilding of the olfactory system. We have tested this hypothesis by examining the degree of spatial segregation in the olfactory system of an early and still aquatic living tetrapod, larval *Xenopus laevis*. We report that subregionalization is already well underway in the *Xenopus* sensory surface. A lateral odor processing stream is formed by microvillous receptor neurons and characterized by amino acid responses and Gai as probable signal transducer. A medial odor processing stream is formed by ciliated receptor neurons and characterized by responses to alcohols, aldehydes and ketones, expression of class II odorant receptors, and Golf and cAMP as probable signal transducer. In the olfactory bulb these two streams are more sharply delineated. However, several class I odorant receptors and vomeronasal receptors type I are evenly distributed within the main sensory surface, and even in the olfactory bulb responses to amines and bile acids are not lateralized. Nevertheless, the tendency to spatial segregation appears to be unrelated to the transition from aqueous to airborne olfaction and may be an inherent characteristic of the tetrapod development towards higher complexity of the olfactory system. The amphibian olfactory system as evolutionary intermediate on this path appears thus well-suited to investigate the molecular driving forces behind olfactory regionalization.

Rapid maturation of odor-evoked signaling in adult-born juxtglomerular neurons of the mouse olfactory bulb.

Yury Kovalchuk, Ryota Homma², Yajie Liang¹, Anatoliy Maslyukov¹, Marina Hermes¹, Yovica Ninkovic³, Magdalena Götz³, Lawrence Cohen², Olga Garaschuk¹

¹University of Tübingen, Physiology II, Keplerstr. 15, 72074 Tübingen, Germany

²Dept. of Physiology, Yale University, New Haven, CT, 06510, USA

³Helmholtz Zentrum München, Institute of Stem Cell Research, 85764 Neuherberg, Germany

Juxtglomerular neurons (JGNs) of the mammalian olfactory bulb are generated throughout the entire life. Both their integration into the existing neuronal network and their survival depend on sensory activity, but the time point at which adult-born neurons start responding to sensory stimuli is still unknown. To address this issue we fluorescently labeled adult-born JGNs by injection of GFP-encoding retrovirus into the rostral migratory stream and we monitored sensory-evoked signals in these cells by means of *in vivo* 2-photon Ca²⁺-imaging. Adult born JGNs started to appear in the glomerular layer of the dorsal olfactory bulb around 8 days post-injection (DPI). Surprisingly, sensory-evoked Ca²⁺ signals in these cells were observed as early as DPI 9. Already at DPI 9 some JGNs responded to the entire range of odorant concentrations tested (0.1-9% of saturated vapor). In most cases the odorant sensitivity of adult born cells closely resembled the odorant sensitivity of the parent glomerulus and did not differ from that of the surrounding GFP-negative cells. At a given odorant concentration the median amplitude of odorant-evoked Ca²⁺ transients in the adult born cells was 77% (n=10; 1.5 % of saturated vapor) compared to the median amplitude of surrounding GFP-negative neurons. At DPI 9-12 62% of adult born cells (n=12) showed spontaneous action potential (AP) firing. Median AP frequency in these cells was 1.9 Hz and thus somewhat lower than that of GFP-positive JGNs at DPI 90 (3.6 Hz, n=8). Adult born cells also responded to the application of an odorant with an increase of action potentials frequency. Taken together our data strongly suggest that adult born JGNs start responding to sensory stimuli shortly after their arrival to the glomerular layer. In terms of response amplitude and odorant-sensitivity their odor-evoked responses closely resemble those recorded from the neighboring mature neurons, implying a remarkably rapid integration of adult-born cells into the glomerular neuronal network.

Olfactory related gene expression in the antenna of leaf-cutting ants (*Atta vollenweideri*).

Sarah Koch, Bill S. Hansson², Christoph J. Kleineidam¹, Ewald Grosse-Wilde²

¹University of Konstanz, Neuroethology, Universitätsstr. 10, 78464 Konstanz, Germany

²Max Planck Institute for Chemical Ecology, Beutenberg Campus, Hans-Knöll-Straße 8, 07745 Jena, Germany

Leaf-cutting ants are evolutionary derived social insects with elaborated division of labor and tremendous colony sizes with millions of workers. Their social organization is mainly based on olfactory communication with different pheromones and is promoted by a pronounced size-polymorphism of workers that show distinct odor-guided behaviors (1). Size polymorphism and distinct behaviors are also correlated to different antennal lobe phenotypes (2,3). In order to unravel caste and subcaste specific expression of genes involved in olfaction, we first sequenced the antennal transcriptome to identify members of olfactory related gene families (ORs, GRs, IRs, OBPs, CSP, and SNMPs), and secondly we screened microarrays in search for differentially expressed genes.

In the transcriptome data of *A.vollenweideri* we identified 185 odorant receptor (OR) coding genes, and phylogenetic comparisons revealed that one of these genes is the ortholog of the conserved odorant-receptor co-receptor (ORCo). Another OR is highly expressed in the antennae of large workers (relative expression >3 in large workers compared to tiny workers), indicating that the corresponding neurons terminate in the macroglomerulus of large workers, which is responsible for trail-pheromone detection. Three ORs are highly expressed in males, and the antennal lobes of males contain three macroglomeruli, which all three are presumably for sex-pheromone detection. In ants, an expansion of the 9-exon OR subfamily has been described (4), and all the pheromone receptor candidates that we identified in *A.vollenweideri* are members of this 9-exon subfamily. For some of the well supported OR subfamilies of ants, we did not find any orthologs, and conclude that we missed a substantial number of OR coding genes in our transcriptome analysis.

We identified only two gustatory receptor (GR) coding genes in *A.vollenweideri* because the antenna is not the main gustatory organ and only a subset of GRs is expressed. We found an ortholog to the sugar receptor GR1 of *Apis mellifera*.

A total of 14 odorant binding protein (OBP) coding genes, with 3 orthologs to antennally expressed OBPs of *A.mellifera* could be identified in our transcriptome data (5). The number of expressed OBP coding genes in *A.vollenweideri* is similar to the antennally expressed OBP coding genes in *A.mellifera* (5).

We found 17 chemosensory protein (CSP) coding genes in *A.vollenweideri*, with some of the CSP coding genes clustered in a well separated subgroup which seems to be an ant-specific expansion. In *A.vollenweideri* the number of expressed CSP coding genes is much higher than compared to *A.mellifera* where only 4 CSP coding genes are antennally expressed (6).

1. Kleineidam CJ, Rössler W, Hölldobler B, Rosces F (2007) Journal of Insect Physiology 53: 1233-1241.
2. Kelber C, Rössler W, Kleineidam CJ (2010) Developmental Neurobiology 70: 222-234.
3. Kuebler LS, Kelber C, Kleineidam CJ (2010) Journal of Comparative Neurology 518: 352-365.

4. Zhou X, Slone JD, Rokas A, Berger SL, Liebig J, Ray A, Reinberg D, Zwiebel LJ (2012) *PloS Genetics* 8(8): e1002930.
5. Forêt S, Malezka R (2006) *Genome Research* 16: 1404-1413.
6. Forêt S, Wanner KW, Malezka R (2007) *Insect Biochemistry and Molecular Biology* 37: 19-28.

SHORT-TIME EXPOSURE TO VARIOUS ODOR STIMULI OR ODOR DEPRIVATION AFFECTS THE DISTRIBUTION OF FOS POSITIVE CELLS IN THE OLFACTORY SYSTEM NEUROGENIC AREA OF THE RAT

Kamila Fabianova, Juraj Blasko¹, Marcela Martoncikova¹, Eniko Racekova¹

¹Institute of Neurobiology, Slovak Academy of Sciences, Institute of Neurobiology, Soltessovej 4-6, 04001 Kosice, Slovakia

The present study demonstrates that single exposure of adult and newborn rats to various odor stimuli or odor deprivation induces immediate changes in Fos positivity within the olfactory system neurogenic region, which is represented by subventricular zone (SVZ), the rostral migratory stream (RMS) and the olfactory bulb (BO). Adult rats were exposed to artificial odor or natural odor (cat odor) for 2 hours. P7 rats were subjected to odor deprivation. To induce odor deprivation in newborn rats, we used a well-described model of maternal separation. Rat pups in the age of 7 days were separated from the dam for 120 minutes. After finishing the experiments immunohistochemical localization of Fos was studied. We have found that even single exposure to odor stimuli or odor deprivation represents a stressful event that caused changes in number and distribution of Fos positive cells in examined neurogenic region and that individual parts of this region respond to stressful stimuli differently. Fos immunohistochemistry disclosed selective increase of Fos positive cell in the SVZ and in the close vicinity of the RMS in adult experimental rats exposed to artificial odor stimuli as well as in adult rats exposed to natural odor stimuli. There were no Fos positive cells in the RMS of adult control rats. In contrast, in the adult rats exposed to artificial odor stimuli as well as in the rats exposed to natural odor stimuli we detected a few FOS positive cells in all anatomical parts of RMS. In the BO of adult control rats the Fos positive cells were located mainly within the glomerular and granular cells layer and small amount of Fos positive cells was scattered within the external plexiform layer. Exposure to artificial odor stimuli caused increase in the number of Fos positive cells in all three mentioned layers of the BO. In adult experimental rats exposed to natural odor stimuli we detected changes in Fos distribution only in the accessory olfactory bulb. In P7 control rats there were any Fos positive cells present neither in the RMS nor in the close vicinity of it, but some Fos positive cells were detectable in the SVZ. In the newborn rats exposed to odor deprivation we detected the appearance of Fos positive cells in close vicinity of the RMS, but there were no Fos positive cells within the RMS. Odor deprivation also increased the number of Fos positive cells in the SVZ. In the BO of P7 control rats Fos positive cells were present in the granular layer, mitral cells layer and in the glomerular layer. Odor deprivation resulted in an increase in the number of Fos positive cells within all of these three layers and a small number of Fos positive cells were visible also in the internal plexiform layer. Our results suggest that the olfactory system neurogenic region possesses the pathways to transmit the signals needed for Fos expression.

Supported by the VEGA grants 2/0114/12; 2/0181/11

Post-stimulus firing and the corresponding olfactory search strategy

Nicole Voges, Antoine Chaffiol², Philippe Lucas³, Dominique Martinez¹

¹ LORIA, Vandoeuvre-lès-Nancy, France

² Dept. of Neurosci., Ohio State Univ. Col. of Med., Columbus, OH

³ INRA, Versailles, France

The mating race of moths is hampered by a discontinuous distribution of pheromone patches. A male moth searching for a mate relies on an optimized search strategy. Upon sensing a pheromone patch, the moth surges upwind whereas losing the pheromone leads to an extended casting until the pheromone plume is reacquired. Pheromone-sensitive neurons in the antennal lobe of *Agrotis ipsilon* moths can guide such an action selection. These neurons typically exhibit multiphasic responses: (1) A burst of spikes after stimulus onset (the On) followed by an inhibitory period. The On is assumed to induce surging, a straight upwind movement. (2) A tonic rebound excitation after stimulus offset (the Off) which is assumed to signal the loss of the stimulus and therefore initiates casting. We here suggest an extended behavioural model that includes two different (but not necessarily discrete) casting strategies based on a separation between Off and baseline activities. The Off indicates a recent loss of the pheromone and induces crosswind zigzagging (assuming that the moth is still inside the plume). Baseline activity, however, indicates the final loss of the stimulus and initiates spiral casting (moth outside the plume). Analyzing the corresponding neurophysiological recordings, we develop a computational model that reproduces the experimental data. In particular, we aim to investigate whether the transition from Off to baseline activity is a discrete or rather a continuous process. The resulting neuron model is then used to control a robot with insect antennae as pheromone sensors.

Poster Topic

T20: Somatosensation: Touch, Temperature, Proprioception, Nociception

- T20-1A** Infrared vision in snakes – How neurons in the rattlesnake's tectum opticum respond to a moving warm object
Felix Kaldenbach, Tobias Kohl, Horst Bleckmann
- T20-2A** Enhanced responses to oddball stimuli in the rat barrel cortex – an animal model for human mismatch negativity?
Steffen Klein, Manuel Lemos M. Rodrigues, Klaus Funke
- T20-3A** Neuronal correlates of whisker stimulation in wildtype mice and the NRG1 mouse model of schizophrenia
Claudia Schreiner, Thomas Bessaih, Ted Abel, Dirk Feldmeyer, Diego Contreras
- T20-1B** The transcription factor c-Maf controls touch receptor development and function
Hagen Wende, Stefan G. Lechner, Cyril Cheret, Steeve Bourane, Maria E. Sheean, Alexandre Pattyn, Katja Reuter, Francis L. Munier, Patrick Carroll, Gary R. Lewin, Carmen Birchmeier
- T20-2B** Activity localisation of sound transducing TRP channels via in vivo Ca²⁺ - Imaging
Robert Jago Wiek, Martin Göpfert
- T20-3B** Cold- and warm-receptor neurons of the sensillum coelocapitulum of the ant *Camponotus rufipes*
Manuel Nagel, Christoph J. Kleineidam
- T20-1C** An elaborate subgenual organ complex in stick insects
Johannes Strauß
- T20-2C** Encoding of touch location and intensity by neurons of the medicinal leech *Hirudo medicinalis*
Gerrit Hilgen, Friederice Pirschel, Jutta Kretzberg
- T20-3C** LDCV release from DRG neurons and its modulation by NPY
Anneka Bost, Barbara Niemeyer, Jens Rettig, Ute Becherer
- T20-1D** Threat, pain, and brain - the effects of fear and anxiety on the perception of pain
Matthias J Wieser, Philipp Reicherts, Antje BM Gerdes, Andreas Mühlberger, Paul Pauli
- T20-2D** Effects of associative and non-associative tactile learning on antennal movement in honeybees (*Apis mellifera* L.)

Simon Würth, Samir Mujagic, Volker Dürr

T20-3D The development of cross-modal processing in the rat primary somatosensory cortex
Kay Sieben, Brigitte Röder, Ileana L. Hanganu-Opatz

Infrared vision in snakes – How neurons in the rattlesnake's tectum opticum respond to a moving warm object

Felix Kaldenbach, Tobias Kohl¹, Horst Bleckmann¹

¹University of Bonn, Institute of Zoology, Meckenheimer Allee 169, 53115 Bonn, Germany

Rattlesnakes can perceive infrared radiation with their pit organs. This enables them to detect and precisely strike towards warm blooded prey even under dark conditions. It is also used to find suitable places for thermoregulation.

All thermal objects of interest to the snake either move (e.g. prey) or produce moving infrared images, when the snake performs scanning movements with its head. Surprisingly, it has not been investigated yet, how the infrared system responds to a moving thermal object.

Electrophysiological recordings of infrared sensitive neurons in the tectum opticum of rattlesnakes (*Crotalus atrox*) were performed. A thermal object was moved in a horizontal direction in front of the snake at various velocities while neuronal activity was measured.

The neurons showed very low or no activity at slow object velocities (even though the object was presented for a long period of time). With increasing velocities neuronal activity also increased and reached a maximum followed by a slight decrease at very high object velocities.

These results, obtained from single neurons, may also be of importance to the snake's infrared detection abilities in general: as opposed to fast moving objects, slow or even stationary objects may not be detected at all when the snake is e.g. motionless couching for prey. In an environment, in which all objects of interest produce moving infrared images, such a sensory system sustainably deals with the precious resource of alertness.

Enhanced responses to oddball stimuli in the rat barrel cortex – an animal model for human mismatch negativity?

Steffen Klein, Manuel Lemos M. Rodrigues¹, Klaus Funke¹

¹Ruhr-Universität Bochum, Neurophysiologie; Med. Fakultät, Universitätsstrasse 150, 44801 Bochum, Germany

Event related potentials (ERPs) quickly decrease in amplitude if identical stimuli are repeatedly presented in a regular sequence. In consequence deviant stimuli produce ERPs with increased amplitude. Even though this phenomenon, called mismatch negativity (MMN), is well known for auditory stimuli in human auditory cortex, the underlying neuronal mechanisms remain to be elucidated.

In order to establish an animal model for MMN, which offers various opportunities for experimental manipulations, the present study tests whether stimulus specific adaptation (SSA) occurs also in the rat barrel cortex (male Sprague Dawley). The main advantage of the barrel cortex is, that the cortical columns are clearly defined by the barrel like structures in layer IV. Furthermore, intra- and inter-columnar and thalamocortical connections are well established and the stimulation of a single whisker allows controlled stimulation of the same afferent subset with varying stimulus parameters. Two vertically aligned electrodes were lowered into the barrel cortex (D2/3) of urethane anaesthetized Sprague Dawley rats. The layer IV-electrode (1 M Ω) was used for multi-unit and LFP recording while the second electrode (0.065 M Ω) in layer II/III was used for LFP recordings, only. A second cohort of rats was used for epidural recordings with a single electrode (0.065 M Ω) above the D2/3 barrel field. During recording the identified principal whisker was repeatedly stimulated at a frequency of 1 Hz (a frequency commonly used in human auditory MMN studies) or 8 Hz (a frequency that is correlated to the active whisking frequency in rats) with the adapting ('standard') stimulus. Pseudorandomly interspersed deviant stimuli differed in deflection speed, amplitude, interval or direction.

While the initial spike-response was always strongly correlated to the stimulation intensity the different deviants resulted in enhanced LFP around 70 and/or 175 ms after stimulus onset which seem to reflect a mismatch negativity-like response in the barrel cortex. However, for final conclusions we would like to wait until we have increased the group sizes what we will certainly do until this conference starts.

Anyway our preliminary data already show that deviant stimuli produce late effects in the somatosensory LFPs. This and the fact that a decrease in stimulus intensity can cause an increase in response leads us to the conclusion that corticocortical connections are involved in this mismatch negativity like neuronal responses.

This study had been supported by the Deutsche Forschungsgemeinschaft (DFG) by a grant to K. Funke (SFB 874, TP A4)

Neuronal correlates of whisker stimulation in wildtype mice and the NRG1 mouse model of schizophrenia

Claudia Schreiner, Thomas Bessaih^{3,4}, Ted Abel⁵, Dirk Feldmeyer^{1,2}, Diego Contreras⁴

¹ Dept. of Psychiatry, Psychotherapy and Psychosomatics, RWTH Aachen, Germany;

² Inst. for Neurosci. and Med., Res. Ctr. Jülich, Germany;

³ CNRS, Univ. Pierre et Marie Curie, France;

⁴ Dept. of Neurosci., Univ. of Pennsylvania, USA;

⁵ Dept. of Biology, Univ. of Pennsylvania

Previous research suggests that early sensory encoding is impaired in schizophrenic patients. Deficits in detecting and interpreting sensory stimuli lead to a range of cognitive and behavioral disturbances characteristic to schizophrenia. The cellular basis of altered sensory processing is not very well understood. Most genetic models of endophenotypes of schizophrenia are mouse models, in which the prominent sensory area is the portion of the somatosensory cortex that represents the vibrissae, i.e., the barrel cortex. In this study, we establish a baseline for barrel cortex responses in mice, which were previously investigated only in rats, in order to compare control animals with mice heterozygous for the schizophrenia risk gene NRG1. We characterized neuronal responses to repetitive whisker deflection across different frequencies in mouse barrel cortex using *in vivo* tetrode recordings from layer 4. Our results indicate that the frequency of whisker stimulation is encoded by the firing rate, as shown by an exponential increase in mean firing rate at increasing stimulation frequencies. In NRG1 mice, mean firing rates increase only linearly and at a smaller magnitude. In addition, in response to a train of stimuli at varying frequencies, NRG1 mice show a significantly smaller response to the first stimulus and slower adaptation during the train in comparison with control animals. Furthermore, we observed phase-locked neuronal responses up to 70 Hz in wildtype mice, suggesting that downstream elements of the circuitry might use temporal coding in addition to rate coding. Neuronal responses in NRG1 animals are less phase-locked to the stimulus, indicating lower firing precision. Our data suggest that the neural circuitry involved in sensory encoding is altered in NRG1 mice, with a lower ability for stimulus detection and discrimination.

The transcription factor c-Maf controls touch receptor development and function

Hagen Wende, Stefan G. Lechner², Cyril Cheret¹, Steeve Bourane³, Maria E. Sheean¹, Alexandre Pattyn⁴, Katja Reuter¹, Francis L. Munier⁵, Patrick Carroll⁴, Gary R. Lewin², Carmen Birchmeier¹

¹Developmental Biology, MDC Berlin

²Molecular Physiology, MDC, Berlin

³Molecular Neurobiology Laboratory, Salk Institute

⁴INSERM Montpellier

⁵Jules Gonin Eye Hospital, Lausanne

The sense of touch relies on the detection of mechanical stimuli by specialized sensory neurons located in the dorsal root ganglia. Distinct classes of mechanosensory neurons detect stimuli including vibration, skin movement and hair deflection, and their ensemble activity allows discrimination of form and texture. The scarcity of molecular data has made it difficult to analyze the development of mechanoreceptors and to define the basis of their diversity and function.

We found that the transcription factor c-Maf is critical for development and function of rapidly-adapting (RA) mechanoreceptors, a subtype of mechanoreceptors that detect vibration and skin movement. Mutation of c-Maf in mice leads to a disruption of the morphology and physiological properties of peripheral sensory endings of RA neurons. Expression analysis of c-Maf mutant DRG neurons revealed downstream targets of c-Maf that contribute to the observed functional deficits of RA mechanoreceptors, like potassium channels and the related transcription factor MafA. MafA is co-expressed with c-Maf in rapidly adapting mechanoreceptors and the two closely related factors might act redundantly.

Pacinian corpuscles are RA mechanoreceptors that specialize in the detection of high-frequency vibrations. They are abundant in human palms and fingers, but in rodents they cluster in periosteal bone. Pacinian corpuscles were particularly strongly affected by the c-Maf mutation. c-Maf mutant mice have only few corpuscles, and these show a highly aberrant morphology. Interestingly c-Maf/MafA double mutant mice completely lack Pacinian corpuscles, while MafA function does not contribute to the observed phenotypes in other sensory endings analysed. Strikingly, sensitivity to high-frequency vibration is reduced in humans who carry a dominant mutation in the c-MAF gene. Thus, our work identifies a key transcription factor that directs the development of rapidly-adapting mechanoreceptors and their end organs.

Activity localisation of sound transducing TRP channels via in vivo Ca^{2+} - Imaging

Robert Jago Wiek, Martin Göpfert¹

¹Universität Göttingen, Department for cellular Neurobiology, Goßlerstraße 1b, 37073 Göttingen, Germany

The sensitivity of hearing in vertebrate and insect organisms is achieved by motile mechanosensory cells amplifying sound.

In flies hearing is localised in the Johnston's organ (JO) which resides in the antenna[2],[3].

TRP (transient receptor potential)- channels such as NompC and lav are essential for hearing in *Drosophila*.

NompC is only expressed in sound perceiving neurons of the JO and is responsible for the nonlinear mechanical amplification of sound [3].

In contrast lav is modulating the amplification processes of NompC [1]. Therefore NompC is a candidate to be the putative mechanotransduction channel. To further validate this we use Ca^{2+} -imaging to localize the region of activity for lav and NompC in the JO neurons [5]. Here we show that lav mutants still exhibit strong calcium responses at the distal part of the JO neurons.

These evidences and the fact that NompC is located at the distal part of the neuron give rise to the hypothesis that NompC is the mechanotransduction channel.

[1] LU & Göpfert 2009 Integr. Comp. Biol

[2] Göpfert et al 2006 Nature Neuroscience

[3] Efertz, Wiek & Göpfert 2011 Current Biology

[4] Howard et al 2010 Cytoskeleton

[5] Kamikouchi, Wiek et al 2010 Nature Protocols

Scolopidium

Cell types

- Sensory Neurons
- Tormogen | Ligament Cell
- Thecogen | Scolopale Cell
- Trichogen | Attachment Cell
- Glial Cell
- Epithelial Cells

Associated Structures

- Cuticule
- CAP
- Scolopale rods

Proteins involved in

Mechanotransduction

- NAN / IAV
- DCX-EMAP
- NompC
- NompA

ciliary rootlet

basal bodies

cilium (9+0)

receptor lymph

ciliary dilation

← mechanical forces stretch →

epithelial cells
cuticule

1µm



Cold- and warm-receptor neurons of the sensillum coelocapitulum of the ant *Camponotus rufipes*

Manuel Nagel, Christoph J. Kleineidam¹

¹University of Konstanz, Neuroethology, Universitätsstraße 10, 78464 Konstanz, Germany

Social insects show elaborated brood care behavior that ultimately lead to fast colony growth. Providing favorable temperature conditions is one of the important measures for successful brood care, and ants frequently translocate their brood to suited conditions inside the nest. The ants' sensitivity and discrimination abilities of temperatures are amazing, and preferred brood temperature can be selected with a precision of only 0.2°C (1). Interestingly, thermal preferences for brood translocation change in the course of the day and match rather the expected than the prevailing temperatures. In addition, the ants' own experience of temperature during development influence the thermal preference later in life (2).

In this study we ask what information about the thermal environment is available to the ants and how this information might be used for the various temperature-guided behaviors, e.g. brood care behavior. We investigate the response properties and sensitivity of three thermo-receptive neurons associated with an important sensillum for thermoreception: the sensillum coelocapitulum (SCA) in the Carpenter ant *Camponotus rufipes*.

We describe a warm-receptive neuron that functions like a thermometer (TM-neuron) with neuronal activity correlated to the prevailing steady-state temperature condition. A second, but cold-receptive neuron, housed in the same sensillum is much more sensitive to temperature changes, but only in a very limited range of temperature. It acts like a temperature switch (TS-neuron), and since the temperature range of the neuron match the preferred brood temperature we speculate that the TS-neuron triggers a behavioral response during brood care. The third neuron associated with the SCA is a cold-receptive neuron like the TS-neuron, however, with a slowly adapting neuronal activity after temperature changes. In response to temperature transients, the neuron's response is phasic with a half-time of about 60 sec (TT_{slow}-neuron). For all three thermo-receptive neurons, the dose response properties are currently analyzed with respect to circadian rhythmicity and thermal experience.

1. Roces F, Núñez JA (1995) Thermal sensitivity during brood care in workers of two *Camponotus* ant species: circadian variation and its ecological correlates. *Journal of Insect Physiology* 41:659-669
2. Weidenmüller A, Mayr C, Kleineidam CJ, Roces F (2009) Preimaginal and adult experience modulates the thermal response behavior of ants. *Current Biology* 19: 1897-1902

An elaborate subgenual organ complex in stick insects

Johannes Strauß

¹Institute of Animal Physiology, AG Integrative Sensory Physiology, IFZ – Heinrich-Buff-Ring 26, 35392 Giessen, Germany

In several orthopteroid and other insects, the subgenual organ, consisting of scolopidial sensilla and located in the proximal tibia of legs, has been investigated with respect to neuroanatomical organisation and sensory physiology. The subgenual organ is an important vibration detector in many insects and is especially suited for comparative studies. So far, the subgenual organ of stick insects has not been documented thoroughly, and some contradicting descriptions about its complexity are available from previous studies. Therefore, the subgenual organ complex is investigated in two phasmid species (*Carausius morosus*, *Sipyloidea sipyilus*) by neuronal tracing using cobalt chloride solution to reveal the number and arrangement of scolopidial sensilla in all three leg pairs. The innervation pattern of the subgenual organ is similar to other orthopteroid insects. In both species of stick insects investigated, the tibial organ consists of a subgenual organ and a distal organ. The subgenual organ contains over 40 scolopidial sensilla. A dense cluster of neurons occurs in the posterior end of the subgenual organ. The distal organ is a linear array of scolopidial sensilla, all innervated by the same nerve. Pairs of sensory neurons with close somata occur only rarely. Compared to other groups known, this is so far an unique organisation present in stick insects. The neuroanatomy of the sense organs is identical between all leg pairs and shows no anatomical indications of functional specialisations despite differences in the leg length and structure.

Sensory thresholds to vibrational stimuli were recorded to investigate the vibration sensitivity of the organ complex. Thresholds of responses to sinoidal vibration stimuli, delivered via a minishaker, were determined by extracellular recordings with silver electrodes in the femur. While the subgenual and distal organ cannot be investigated separately by this approach, the organ complex is clearly responsive to vibrations transferred to the thoracic legs. The threshold curves between the different leg pairs are highly similar in the range of accelerations which elicit neuronal activity.

The comparison of subgenual organs in insects shows a specific organisation of the stick insect distal organ. A rather simple distal organ may have been present in the lineage of orthopteroids, probably linking to the distal organ present in recent cockroaches (*Periplaneta americana*). However, elaborate subgenual organ complexes with distinct sets of linear receptors arrays have originated in Phasmids and Ensifera, apparently independently.

Encoding of touch location and intensity by neurons of the medicinal leech *Hirudo medicinalis*

Gerrit Hilgen, Friederice Pirschel¹, Jutta Kretzberg¹

¹University of Oldenburg, Computational Neuroscience, Carl von Ossietzky Str. 9-11, 26111 Oldenburg, Germany

The ability to discriminate among different stimuli is fundamental for behavioral responses. Even in small neuronal systems, sensory stimuli evoke precise behavioral responses. The medicinal leech (*Hirudo medicinalis*) possesses one of the smallest neuronal systems and reacts in an extremely precise manner to a tactile stimulus [Baca et al. 2005; Thomson and Kristan, 2006]. The muscles contract near the site of the mechanical stimulation where the muscles on the opposite side elongate. This so-called “local bending reflex” is known to be initiated by mechanosensory pressure cells (P cells), which activate a layer of interneurons, which in turn connect to a number of motor neurons [Baca et al., 2005; Kristan et al., 2005]. The P cells are the major sensory neurons driving the local bend response whereas the role of the touch cells (T cells), another mechanosensory cell type, is still under debate for local bending [Lewis and Kristan, 1998; Thomson and Kristan, 2006]. Here, we investigate how the first two layers of this network encode information about the stimulus location and intensity.

We intracellularly recorded the activity of interneurons, P- and T cells, while stimulating the skin of the leech mechanically. The tactile stimuli varied in touch intensity and location. In agreement with Thomson and Kristan [2006], we found for higher intensity stimuli (> 50 mN) that the touch location is accurately encoded by the latency difference of two P cells with overlapping receptive fields. For lower stimulus intensities the latency difference of two T cells leads to the best classification results. In contrast, the stimulus intensity can be classified best by the spike count of single cells. The features of the graded interneuron responses depend clearly on the touch intensity and in a more complex way on the touch location.

To investigate how combinations of location and intensity of touch stimuli are encoded in the network, we optically monitor the cell activity with voltage sensitive dye imaging. We use a new PeT dye [VF2.1.Cl, Miller et al, 2012] that detects very fast voltage changes in neurons and gives bigger responses to voltage than electrochromic dyes. Due to the planar arrangement of the cell bodies this technique allows to study the activity of approximately half of the ~400 cells in the leech ganglion simultaneously, promising new insights in ensemble coding of sensory stimuli.

References:

- Lewis and Kristan, J Neurophysiol 80: 2584-2592, 1998. Miller et al., Proc Natl Acad Sci 109(6):2114-9, 2012
- Baca et al., J Neurophysiol 93: 3560-3572, 2005.
- Kristan et al., J Progress in Neurobiology 76:279-327, 2005
- Thomson and Kristan, J Neurosci 26: 8009-8016, 2006.

LDCV release from DRG neurons and its modulation by NPY

Anneka Bost, Barbara Niemeyer², Jens Rettig¹, Ute Becherer¹

¹Universität des Saarlandes, Physiologisches Institut, Kirrberger Straße Gebäude 59, 66421 Homburg, Germany

²Universität des Saarlandes, Institut für Biophysik, Kirrberger Straße Gebäude 58, 66421 Homburg, Germany

Dorsal root ganglion (DRG) neurons transmit sensory information and induce inflammatory processes releasing neurotransmitters and neuromodulators through Ca²⁺-dependent exocytosis from synaptic vesicles (SVs) and large dense-core vesicles (LDCVs), respectively. In contrast to the exocytosis of SVs, the fusion mechanism of LDCVs from neurons is poorly understood. Here we investigate the stimulus-secretion coupling in DRG neurons. We used total internal reflection fluorescence (TIRF) microscopy to visualize LDCVs, marked by overexpression of neuropeptide Y (NPY)-Venus, and their fusion in real time. We combined this technique with a field electrode to induce secretion using various stimulation protocols. We found that DRG neurons are reluctant to secrete LDCVs and, unlike LDCV secretion from chromaffin cells, stimulation-secretion coupling was weak. We are now interested in how the secretion can be modulated by neuropeptides.

Threat, pain, and brain - the effects of fear and anxiety on the perception of pain

Matthias J Wieser, Philipp Reicherts¹, Antje BM Gerdes², Andreas Mühlberger¹, Paul Pauli¹

¹University of Würzburg, Department of Psychology, Marcusstr. 9-11, 97070 Würzburg, Germany

²University of Mannheim, Department of Psychology, Schloss, Ehrenhof Ost, 68131 Mannheim, Germany

Pain processing is considerably influenced by emotions such that negative emotions, for instance, increase pain perception. With regard to anxiety, it has been proposed that fear (phasic) and anxiety (tonic) are probably different aversive affective states. In this distinction, fear is characterized by an aversive reaction to the perception of a specific threat stimulus, whereas anxiety is defined by prolonged vigilance to a diffuse, unspecific threat. Moreover, the predictability of upcoming aversive events during fearful anticipation is a key feature for the distinction between transient phasic and sustained tonic fear. It has been proposed that fear versus anxiety might also lead to distinct processing of sensory threatening events. For example, fear and anxiety might have different effects on pain perception with higher pain sensitivity under anxiety, but lower pain sensitivity under fear.

These potential differences were investigated by comparing conditioned fear (CF/fear), where the threat is predictable, and instructed fear (IF/anxiety), where the imminent threat is unpredictable. Forty-five participants (CF n=23; IF n=22) received thermal pain stimuli while watching cues indicating threat or safety. Before this test phase, the CF group underwent classical fear conditioning with visual cues either predicting threat (aversive electric stimulus) or safety, whereas the IF group was only verbally instructed about these contingencies but actually never received a shock. Pain and cue ratings, skin conductance level (SCL) and BOLD responses (fMRI) to the cues and the thermal pain stimuli were obtained in the test phase. Cue ratings showed successful threat induction and the SCL was higher in response to threat compared to safety cues in both groups. In addition, affective pain ratings in later threat compared to safety trials were increased in the instructed fear group, only. BOLD analysis for IF revealed that threat compared to safety cues elicited higher activation in visual and fear-related areas. For CF, the activity pattern was similar but less pronounced. An interaction of pain and threat revealed higher sensory and threat-related activity in IF, whereas in CF activity increase was restricted to fear-related areas. Results demonstrate increased subjective and neurophysiological pain processing during instructed fear, in line with theories proposing heightened attention and sensory sensitivity during anxiety. However, fear-related analgesia was not found in the fear conditioning group. The latter finding might indicate that fear conditioning did not elicit elevated levels of arousal probably necessary for analgesic effects.

Effects of associative and non-associative tactile learning on antennal movement in honeybees (*Apis mellifera* L.)

Simon Würth, Samir Mujagic^{1,2}, Volker Dürr^{1,2}

¹Bielefeld University, Biological Cybernetics, Universitätsstr. 25, 33615 Bielefeld, Germany

²CITEC - Cognitive Interaction Technology - Center of Excellence, Bielefeld University, Universitätsstr. 25, 33615 Bielefeld, Germany

The honeybee is a model organism for studying tactile learning and can be trained in an operant conditioning paradigm to discriminate tactile object features such as edges, corners or grooves with their antennae. Object discrimination requires active spatial sampling by the antennal tip and, thus, changes in antennal posture and movement. The main objective of this study is to analyse the kinematics of fine-scale antennal sampling pattern and to investigate the effect of different forms of learning on the antennal motor behaviour in honeybees.

In a first set of experiments, we examined how the spatial distribution of antennal tip position, the movement speed and range of the antennal tip differed before during, and after presentation of a tactile stimulus (effect of motor learning, i.e., non-associative changes in motor behaviour). Moreover, we measured how the same parameters differed between conditioned and unconditioned "naïve" bees (effect of associative learning, i.e., operant conditioning of the proboscis-extension reflex in response to tactile stimulation). Experiments were carried out for two groups of 20 bees. Only one group was conditioned to the tactile stimulus. Both groups showed the typical antennal scanning behaviour (Erber et al., 1997, J.Comp.Physiol.A 181:355-365). Antennal movement was recorded before, during, and after a 1 minute presentation of a tactile stimulus (metal surface with engraved horizontal grating with 150 µm wavelength).

- With regard to motor learning (non-associative effects), our results revealed (1) that median antennal posture shifted medially, i.e., towards the stimulus, after stimulus presentation; (2) however that the antennal tip did not reach the actual stimulus location more often after presentation; (3) that the median movement speed during and after the presence of the tactile stimulus differed, being lower after presentation. We conclude that tactile sampling experience as brief as 1 minute affects both range and speed of subsequent antennal movement. This corroborates earlier results on tactile motor learning (Erber et al., 1997), though with the use of much shorter stimulus duration (Erber et al. used 10 minutes). Other than the method used by Erber et al., our method allowed tracking of antennal movement during tactile sampling. Finding 2 differed from the results of Erber et al., but this may be due to the different viewing plane (here: horizontal; Erber et al.: frontal)

- After tactile conditioning, bees also showed a mediad shift of the antennal posture (as in 1), but (4) the antennal tip spent significantly more time on the stimulus surface in conditioned bees than in naïve bees; the latter effect did not persist after stimulus presentation (as in 2); In contrast to naïve bees, (5) conditioned bees showed increased median antennal movement speed after stimulus presentation (opposite effect to 3). Thus, tactile conditioning strongly affects antennal movement

behaviour. It leads to an increase in tactile sampling of the object presented, and to an increase of overall motor activity.

As both associative and non-associative forms of learning affect antennal searching and sampling behaviour, it needs to be tested whether the changes in antennal movement are only a side-effect or rather an essential aspect of tactile learning.

The development of cross-modal processing in the rat primary somatosensory cortex

Kay Sieben, Brigitte Röder², Ileana L. Hanganu-Opatz¹

¹UKE, ZMNH, Developmental Neuroscience, Martinistr. 52, 20246 Hamburg, Germany

²University Hamburg, Biological Psychology and Neuropsychology, 20146 Hamburg, Germany

Real-world perception of environment relies on integration of information from multiple senses. The classical idea of a hierarchical sensory organization is challenged by recent evidence from both human and primate work showing that multisensory processing is already taking place in putatively unisensory neocortical regions like the primary cortices. We recently showed that visual inputs modulate sensory information processing in the primary somatosensory cortex (S1) by affecting its network activity. However, the mechanisms underlying the development of cross-modal effects in primary sensory cortices remain largely unknown. To elucidate this issue, we focused on the convergence of visual and tactile information in the developing Brown Norway rat.

Light flash and whisker deflection were combined with multi-site extracellular recordings in the primary visual and somatosensory neocortices of Brown Norway rats *in vivo* during different developmental states.

Pre-juvenile rats without the experience of active multimodal exploration (eyes are closed, but retina is light sensitive) already processed cross-modal information in the S1. Bimodal visual-somatosensory stimulation augmented the evoked potentials and changed the induced activity pattern, these effects being comparable to those observed in mature rats. Direct anatomical connections between the pre-juvenile primary visual and somatosensory networks were identified via retrograde anatomical tracing. They present a substrate of cross-modal processing. To elucidate the role of unisensory development in the context of multisensory processing we deprived rats of tactile experience during the critical period by cutting the whiskers bilaterally from birth to postnatal day 6. The sensory deprivation had a direct impact not only on the local network anatomy and function, but also on bimodal processing in the S1. Thus, a proper sensory maturation, but not active multisensory experience, seems to be indispensable for the development of multisensory processing in primary cortical areas.

Supported by the Landesexzellenzinitiative Hamburg

Poster Topic

T21: Motor Systems

- T21-1A** Characterization of a Behavioral *Samuel* Mutant Generated by *P* Element-Mediated Gene Trapping in *Drosophila melanogaster*
Roswitha Jungnickel, Roland Strauss, Bert R. E. Klagges, Heinz Sass
- T21-2A** Determining mode of action of pymetrozine – From single cell to system level
Judith Förster, Ulrich Ebbingshaus-Kintscher, Ansgar Büschges
- T21-3A** Decoding of reach and grasp kinematics from primate premotor, motor, and parietal cortex
Veera Katharina Menz, Stefan Schaffelhofer, Hansjörg Scherberger
- T21-4A** Insect Leg Targeting: Aiming Accuracy Depends on Activity of Target Leg
Anne Wosnitza, Jennifer Engelen, Matthias Gruhn
- T21-5A** Intersegmental coordination in the swimmeret system: Neuronal properties of the descending coordinating neuron
Swantje Grätsch, Carmen Smarandache-Wellmann
- T21-6A** LFP signals in macaque parietal hand area AIP represent spatial information
Sebastian J. Lehmann, Hansjörg Scherberger
- T21-7A** Influence of temperature on the rhythmic activity of the Swimmeret System in Crayfish (*Pacifastacus leniusculus*)
Felix Blumenthal, Carmen Smarandache-Wellmann
- T21-8A** Calcium imaging of retrogradely labeled retractor coxae neurons in the stick insect *Carausius morosus*
Jens Goldammer, Cathleen Rotte, Joachim Schmidt, Peter Kloppenburg, Ansgar Büschges
- T21-9A** GABAergic innervation of the ciliary ganglion in pigmented and albino rats
Miriam Barnerssoi, Anja K.E. Horn
- T21-1B** Characterization of Muscle Fiber Types in an Insect Leg
Elzbieta Godlewska, Ansgar Büschges, Matthias Gruhn
- T21-2B** Body-Side Specificity of Descending Control of Leg Motor Activity during Turning in an Insect
Matthias Gruhn, Philipp Rosenbaum, Anke Borgmann, Ansgar Bueschges
- T21-3B** Control of motor activity in a walking stick insect (*Carausius morosus*) leg with and upon loss of ground contact

- T21-4B** Calcium FRET-imaging indicates bilateral power balancing in transgene *Drosophila* flight muscle
Fritz-Olaf Lehmann, Dimitri Skandalis
- T21-5B** Control of handling food by the “hands” in insect feeding
Reinhold Hustert, Anh-Vu Nguyen
- T21-6B** Single trial neuronal correlates of decision-making for hand grasping in macaque area F5 and AIP
Benjamin Wellner, Jonathan A Michaels, Wiebke Alexandra Wellner, Hans Scherberger
- T21-7B** Embodied Joint Movement Control: Interaction of Neural Networks and Passive Muscle Properties in the Stick Insect
Arndt von Twickel, Christoph Guschlbauer, Charalampos Mantziaris, Anna Schwarz, Ansgar Büschges
- T21-8B** Allocentric planning of immediate reach movement is prone to induced Roelofs illusion
Bahareh Taghizadeh, Alexander Gail
- T21-9B** Interdependence of movement planning and choice behavior for decisions among multiple reach goals
Lalitta Suriya-Arunroj, Alexander Gail
- T21-10B** Activity of DUM Neurons in the Subesophageal Ganglion during Locomotor Behavior in the Stick Insect
Thomas Stolz, Martin Heß, Joachim Schmidt
- T21-1C** Calretinin inputs are confined to motoneurons for upward eye movements in primates
Christina Zeeh, Bernhard J. Hess, Emmanuel Chen Ngwa, Julia M. Feige, Anja K.E. Horn
- T21-2C** Neural control of forward and backward walking in insects
Philipp Rosenbaum, Ansgar Bueschges
- T21-3C** Whole-cell recordings from mouse forelimb motor cortex neurons during targeted reaching.
Birgit Christina Voigt, Luc Estebanez, James F.A. Poulet
- T21-4C** Modulation in the processing of movement signals from the leg during curve walking of an insect
Katja Hellekes, Ansgar Büschges
- T21-5C** Immunocytochemical studies on the nervous system of Onychophora (velvet worms): insights into the evolution of arthropod body segmentation
Georg Mayer, Hans-Joachim Pflüger, Paul Anthony Stevenson
- T21-6C** Network dependent activation of a hyperpolarizing conductance in motoneurons enhances neuronal synchrony
Boris P. Chagnaud, Andrew H. Bass

- T21-7C** Spinal corollary discharge in mechanoreceptor-related nerves mediates information about locomotor activity
Roberto Banchi, Boris P. Chagnaud, Hans Straka
- T21-8C** Encoding of intended reach movement direction in Local Field Potential Phase in monkey fronto-parietal reach area PRR.
Pablo Martinez-Vazquez, Alex Gail
- T21-9C** Extrinsic and intrinsic factors influencing spontaneous and reinforcement-induced pitch changes in zebra finch song
Anna Ewa Stepień, Alessandro Canopoli, Alexei Vyssotski, Valance Yanxin Wang, Gagan Narula, Richard Hahnloser
- T21-10C** Characterization of octopaminergic unpaired median neurons in the suboesophageal ganglion of *Manduca sexta*
Jessika Erdmann, Hans-Joachim Pflüger
- T21-1D** Synergy of motor control pathways for aerial steering in *Drosophila*
Ruben Andres Berthé, Peter Schützner, Fritz-Olaf Lehmann
- T21-2D** The development of tyraminerpic/octopaminergic neurons of *Drosophila* muscles integrated in an atlas
Konstantin Lehmann, Christina Zube, Stephan Sigrist, Carsten Duch, Hans-Joachim Pflüger
- T21-3D** Spatio-temporal organization of local field potential oscillations in the monkey motor cortex
Lyuba Zehl, Thomas Broschier, Alexa Riehle, Sonja Grün, Michael Denker
- T21-4D** Peptidergic modulation of larval *Drosophila* locomotor activity
Dennis Pauls, Kristina Jessen, Christian Wegener
- T21-5D** No evidence for distinct gaits in *Drosophila*
Till Bockemühl, Anne Wosnitza, Michael Dübbert, Henrike Scholz, Ansgar Büschges
- T21-6D** Correction Movements and Spatial Coordination in Multipedal Locomotion
Leslie M. Theunissen, Subhashree Vikram, Volker Dürr
- T21-7D** The importance of charged residues in the intracellular TM3-4 loop of the inhibitory glycine receptor
Georg Langlhofer, Bea Unterer, Carmen Villmann
- T21-8D** Identification of individual neurons in EMG and hook electrode recordings using spike sorting techniques
Sophie Ann Bradley, Luis A. Camunas Mesa, Ria Cooke, Rodrigo Quián Quiroga, Tom Matheson
- T21-9D** Monitoring of reflex activity and motor function in spastic rats, nNOS, PV immunoreactivity and astrocyte's expression in spinal cord after repeated baclofen treatment
Andrea Kucharíková, Ludmila Hricová, Alexandra Kisucká, Andrea Schreiberová, Štefánia

Gedrová, Nadežda Lukácová

Characterization of a Behavioral ***Samuel*** Mutant Generated by ***P*** Element-Mediated Gene Trapping in ***Drosophila melanogaster***

Roswitha Jungnickel, Roland Strauss², Bert R. E. Klagges³, Heinz Sass³

¹LIN - Leibniz-Institut für Neurobiologie Magdeburg, Genetik von Lernen und Gedächtnis, Brenneckestraße 6, 39118 Magdeburg, Germany.

²Johannes Gutenberg-Universität Mainz, Institut für Zoologie III-Neurobiologie, Colonel Kleinmann-Weg 2, 55128 Mainz, Germany.

³Universität Leipzig, Institut für Biologie, Lehrstuhl für Genetik, Talstraße 33, 04103 Leipzig, Germany.

In *Drosophila* (and other organisms), motor activity provides a basic precondition for any behavior ranging from search for food over grooming up to courtship since all of these actions involve movements or positional changes of the fly within its immediate environment. In this study, flies carrying a *Samuel*^{L796} mutant allele generated by *P* element-mediated gene trapping were shown to be defective in walking, grooming and righting. Intriguingly, such a phenotype is not yet known for *Samuel*. As revealed via high-speed video recording during walking, homozygous mutant flies display atypical leg swing phases by partially executing inhomogeneous leg trajectories and exhibit prolonged or irregular stance phases. The otherwise robust pattern of the stereotyped alternating tripod insect gait is dramatically deranged. Correspondingly, in Buridan's paradigm, *Samuel*^{L796} mutants are significantly less active and lower in walking speed. When coated with powder in a grooming assay, these animals are unable to remove the applied dust from their body surfaces. Decapitated mutant flies are also impaired in righting behavior which takes significantly longer. Upon *P* element excision in revertants, all phenotypic aberrations were rescued to wild-type levels, proving that the behavioral defects of the mutant are due to transposon insertional mutagenesis. In addition to the phenotypic description of this *Samuel*^{L796} mutant, the wild-type gene locus was inspected on the transcript level. Rapid amplification of cDNA ends (RACE) revealed nine alternative *Samuel* transcripts in adult flies. There is experimental evidence that at least one of these alternative mRNAs is expressed within the larval leg imaginal discs. This finding is in line with the observed leg dysfunctions and the consequential severe impairments of walking, grooming and righting in this *Samuel*^{L796} mutant.

Determining mode of action of pymetrozine – From single cell to system level

Judith Förster, Ulrich Ebbingshaus-Kintscher², Ansgar Büschges¹

¹University of Cologne, Animal Physiology , Zùlpicher Straße 47b, 50674 Cologne, Germany

²Bayer CropScience AG, 40789 Monheim am Rhein

Pymetrozine is one selective insecticide against aphids. It induces a stretched posture of the legs and proboscis. This effect vanishes over time after application. Experiments in locusts indicate that pymetrozine affects gross sensitivity of sensory neurons in the fCO (Ausborn et al., 2005; Kaufmann et al., 2004). However, the mode of action of pymetrozine is presently unknown. That means it is not known how single sensory cells of the fCO are affected and which target sides in the fCO exist.

So far two possible explanations exist: (1) Pymetrozine affects the mechano-electrical transduction process or (2) affects transformation of receptor potential towards action potentials.

The stick insect, *Carausius morosus*, that has well characterized sensory organs, is also affected by pymetrozine by lifting its legs. Potent concentrations of pymetrozine start at 100 nM. Single fCO sensory cells are sensitive to changes of position (P), velocity (V) and/or acceleration (A) of the tibia (Hofmann et al., 1985). The reactions of these sensory cells to pymetrozine can be recorded intracellularly in the segmental ganglion (n = 10). We show that P-sensitive (n = 2) and V-sensitive (n = 5) cells become tonic during stimulation after pymetrozine application. Independent of cell type, active sensory cells (P: n = 1; V: n = 3) as well as silent sensory cells (P: n = 1; V: n = 2; A: n=1) become tonically active with pymetrozine treatment already in the absence of fCO-stimulation. On average 25 sec after the tonic activation, 70 % of sensory cells became inactive. From these results it is conceivable that pymetrozine acts either through a modulation of the mechano-electrical transduction processes without needing a mechanical stimulus or influences the receptor potential.

Decoding of reach and grasp kinematics from primate premotor, motor, and parietal cortex

Veera Katharina Menz, Stefan Schaffelhofer¹, Hansjörg Scherberger¹

¹German Primate Center, Primate Neurobiology, Kellnerweg 4, 37077 Göttingen, Germany

The primate motor, premotor, and parietal cortex are crucially involved in the planning and execution of hand movements. Specifically, neurons in the ventral premotor cortex (area F5) and the anterior intraparietal area (AIP) have been shown to represent grip type, wrist orientation, and grip aperture during movement planning and execution. However, it is unclear to what extent these higher-order planning areas represent not only intended hand shapes, but also continuous hand kinematics during grasping. Here we present the decoding of individual finger and arm angles from spiking activity in F5, AIP, and primary motor cortex (M1).

A rhesus monkey (*Macaca mulatta*) was trained to perform a delayed grasping task with ~50 objects of different shape, size, and orientation presented on a carousel in front of the monkey. Hand kinematics were monitored with a sensor glove allowing the continuous tracking of 27 DOF of all fingers, wrist, and arm angles in 3D space (Schaffelhofer et al. 2012). Neural data was recorded using 192 chronically implanted microelectrodes (FMAs, Microprobe Inc.) that were distributed evenly in the hand areas of F5, AIP, and M1. After offline spike sorting (WaveClus, Plexon Offline Sorter), we utilized a Kalman Filter to predict hand kinematics from the population activity of individual areas.

For each finger, we decoded 4 different DOF (spread, MCP, PIP, DIP angles). As expected, neural signals from M1 predicted these kinematics best: for fingers 1-5 we found a correlation coefficient (CC) between predicted and real movement of 0.60, 0.65, 0.71, 0.73, and 0.59, respectively. Predictions from area F5 provided surprisingly good results as well (CC: 0.45, 0.56, 0.59, 0.62, 0.52), whereas decoding from AIP yielded less accurate results (CC: 0.37, 0.39, 0.47, 0.49, 0.42).

Although the recording electrodes were carefully positioned in the hand areas of M1, F5, and AIP, we were able to decode the wrist and arm angles (yaw, pitch, and roll of both wrist and shoulder, elbow angle) with high precision as well: We obtained a CC of 0.74 for wrist angles and a CC of 0.86 for arm angles when decoding from M1, a CC of 0.57 (wrist), and 0.83 (elbow & shoulder) when decoding from F5, and a CC of 0.43 (elbow), and 0.61 (elbow & shoulder) when decoding from AIP.

Furthermore, we investigated the information delay between neural activity and hand kinematics by introducing a time gap between the neural activity used for decoding a specific kinematic data sample and the respective data sample (neural data always preceded the kinematic sample). Decoding performance dropped down significantly with increasing gaps when using M1 (CC averaged across all DOF for a gap of 900ms: 0.46), especially during time periods of forward movement (CC: 0.34). Longer gaps decreased decoding performance when using F5 as well, even though the effect was less than in M1 (CC for a gap of 900ms: 0.51; CC during movement: 0.42). In contrast, change of gap length did not show any impact on decoding performance when using AIP (CC for a gap of 900ms: 0.45; CC during movement: 0.42).

These results suggest that area AIP encodes rather time independent information, whereas area F5 seems to contain at least some amount of movement and time dependent information. Together, these findings indicate that area F5 could be used for movement prediction in addition or alternatively to area M1, whereas area AIP is less suited for decoding of continuous hand and arm movements.

Insect Leg Targeting: Aiming Accuracy Depends on Activity of Target Leg

Anne Wosnitza, Jennifer Engelen¹, Matthias Gruhn¹

¹University of Cologne, Animal Physiology, Zùlpicher Straße 47b, 50674 Cologne, Germany

Observations of climbing stick insects (*Carausius morosus*) on a grid as well as previous work on a tread-wheel setup (e.g. Cruse 1979) suggest that stick insects perform targeting movements with their legs to find support for middle- and hind legs more easily. Based on such behavioral experiments, it has been assumed that the animals use position information from front- and middle legs to control the anterior extreme position of the ipsilateral middle- and hind legs, respectively. Here, we address the question whether this targeting of the middle- and hind legs is also present when influences through mechanical coupling through the ground are removed in a slippery surface setup (Gruhn et al. 2006). Targeting under these conditions would emphasize the role of underlying neuronal mechanisms.

First, we looked for evidence of targeting in hind- or middle legs during walking on the slippery surface, when the rostral neighboring middle- or front leg, was positioned at a defined position relative to the body (cf. Cruse, 1979). Targeting precision during the first step of a walking sequence was analyzed with respect to dependency on that aiming position. Under these conditions, the touchdown positions of the middle and hind legs show a weak correlation parallel (x) and perpendicular (y) to the body axis. However, no correlation was observed between the front and middle legs. Secondly, we studied whether targeting occurred during continuous walking of an intact animal tethered above the slippery surface. Under these conditions, the touchdown positions of the middle and hind legs were correlated to the corresponding position of the front and middle legs parallel and perpendicular to the body axis, respectively. However targeting precision declines with more rostrally located aims.

These results suggest that a neural mechanism exists for controlling the anterior extreme position of the posterior leg but that movement or activity of the anterior leg may be necessary for processing of the position information.

Intersegmental coordination in the swimmeret system: Neuronal properties of the descending coordinating neuron

Swantje Grätsch, Carmen Smarandache-Wellmann¹

¹University of Cologne, Animal Physiology, Zülpicher Straße 47b, 50674 Köln, Germany

We are investigating descending neuronal signals needed for coordinated locomotor output in the crayfish swimmeret system. Central pattern generators (CPGs) located in four of the six abdominal ganglia drive the locomotor activity in a stable and well-coordinated fashion. This and the simple neuronal organization makes the swimmeret system to a powerful model to investigate neuronal and synaptic properties of coupled oscillators that are needed for goal directed locomotion.

Abdominal ganglia A2 - A5 innervate the four pairs of swimmerets and drive rhythmic cycles of power-stroke (PS) and return-stroke (RS) movements, which are performed during forward swimming. Each limb is controlled by one individual set of neurons that is located in each hemiganglion. These local circuits generate the rhythmic motor output of alternating PS and RS bursts due to reciprocal inhibition of two classes of non-spiking interneurons IPS (3 neurons) and IRS (2 neurons). During active swimming movements, the individual limbs of the swimmeret system are highly coordinated such as the most posterior module is active and the more anterior modules follow this activity with a phase lag of a quarter cycle. This coordination of local circuits is achieved by one ascending and one descending coordinating neuron, which project from their home module to the neighboring ganglia. Coordinating neurons encode information about the activity state of their home module and sent it to the Commissural Interneuron 1 in the neighboring ganglia where this information is decoded and then integrated into the CPG. Therefore the local neuronal circuits are coordinated in this precise fashion.

In this study we focus on the descending coordinating neuron (DSC). This neuron is present in A2 - A4 and encodes information about the activity state and amplitude of the pool of RS neurons in its home ganglion and transmits this information to the posterior modules. We investigated the neuronal properties and the activity changes of DSC when the swimmeret system was excited to different levels. Therefore we recorded DSC intracellularly with sharp microelectrodes in the lateral neuropil. To identify DSC we used morphological (intracellular fill) and physiological methods. Therefore we also recorded the extracellular activity of this neuron with suction electrodes placed on the miniscule tract, only when each extra- and intracellular action potential (AP) matched we started the experiment. We perfused the isolated nervous system with different concentrations of carbachol, a cholinergic agonist, because previous experiments showed that motor neurons change their properties with increased excitation. So we wanted to test how DSC responds to this perturbation. For each excitation level we measured first if there is a change in the activity pattern or the membrane potential of DSC, then we determined the input resistance by injecting short hyperpolarizing pulses in different phases of the locomotor cycle. In this study we show that increasing the excitation level in the swimmeret system induces a depolarization of the membrane potential in DSC and more APs per burst could be observed. Furthermore we demonstrate a decrease in the input resistance when we perfused the nervous system with higher concentrations of carbachol.

LFP signals in macaque parietal hand area AIP represent spatial information

Sebastian J. Lehmann, Hansjörg Scherberger¹

¹DPZ Göttingen, AG Neurobiologie, Kellnerweg 4, 37077 Göttingen, Germany

The anterior intraparietal cortex (AIP) in the macaque brain is strongly involved in the visuo-motor transformation of hand grasping actions. However, the influence of spatial variations during these reach-to-grasp movements has not been analyzed systematically yet. In order to study the representation of spatial factors in the LFP signals we varied target and gaze position in space while monkeys performed a delayed reach-to-grasp task.

Macaques were trained to grasp a handle with one of two grip types (precision and power grip) while the spatial handle and gaze positions were varied independently (three vertical and three horizontal positions; all presentations randomly interleaved). Trials consisted of four epochs (fixation, cue, memory, and movement) during which the monkey maintained eye fixation of a red LED light in darkness (eye position was monitored by optical tracking). To initiate a trial, the monkey placed its hand at the start position and fixated the red LED. In the cue epoch (800ms duration) the handle position was disclosed and the grasp type instructed by the color of a 2nd LED. After a delay of about 1s (planning period) a 'go' signal followed that instructed the animal to execute the grasp movement while maintaining eye fixation. All correct trials were rewarded with a small amount of fluid.

We recorded LFP signals from 246 sites in AIP (147 in animal P, 99 in animal S). In the beta band (13-30 Hz), we found in general a higher percentage of recording sites with significant tuning for the different spatial conditions than for grip type (2-way-ANOVA, $p < 0.05$). The percentages of spatially tuned sites in the task epochs fixation, cue, planning, and movement were 26%, 31%, 31%, and 29% for animal P, and 38%, 55%, 55%, and 46% for animal S. In contrast, the percentage of grip-type tuned sites was lower, but increased during movement execution (animal P: 1%, 6%, 10%, 42%; animal S: 7%, 4%, 7%, 21%). Furthermore, we fitted a combined linear model with the factors grip type, gaze, target, and retinotopic target position to the data. We found that all factors contributed to the spatial representation at a similar level throughout the task.

In addition, using maximum likelihood estimation, we simulated the decoding of the spatial conditions for each task epoch and frequency band. Best results were obtained using the beta band (13-30Hz): the decoding performances for the epochs fixation, cue, planning and movement were 34%, 42%, 48%, and 18% for animal P, and 22%, 46%, 44%, and 34% for animal S (chance level 7.8%). Grip type decoding simulation from the LFP beta band revealed best performances during the movement epoch: 93% in animal P and 73% in animal S (chance level 50%). These findings, i.e., a relatively stable representation of spatial factors in the LFP beta band, together with an increased representation of grip type towards movement execution, are consistent with previous results of single unit activity in AIP during the same task. Together, they suggest that AIP plays an important role for reach and grasp movement coordination.

Influence of temperature on the rhythmic activity of the Swimmeret System in Crayfish (*Pacifastacus leniusculus*)

Felix Blumenthal, Carmen Smarandache-Wellmann¹

¹University of Cologne, Animal Physiology, Zùlpicher StraÙe 47b, 50674 Kùln, Germany

The crayfish, *Pacifastacus leniusculus*, lives in rivers where the temperature range lies between 12 – 20°C. The swimmeret system of the crayfish is used as a model organism to study coordination of central pattern generators. All electrophysiological experiments were done so far at room temperature of around 18 – 20°C. Since temperature can change biophysical parameters in general we tested as a first its influence on the coordinated locomotion of the swimmeret system of this crayfish. The swimmerets are paired limbs attached to the abdomen, which are used for forward swimming or ventilating their burrows. Their muscles are innervated by a part of the central nervous system, the chain of abdominal ganglia. These are bilateral symmetric, so that each limb is driven by its own local pattern module located in each hemiganglion. The limbs move in cycles of alternating power-stroke (PS - retraction) and return-stroke (protraction) activity. These movements are coordinated in a metachronal rhythm, with a progression from posterior to anterior. Thus every cycle starts with a PS-Burst in A5. The PS burst in the more anterior ganglia follow with a characteristic phase lag of 0.25, independent of the frequency of the rhythm and if recorded in intact or isolated conditions. This characteristic coordination from posterior to anterior is maintained by three different neurons, two coordinating neurons (ASC_E and DSC) and Commissural Interneuron 1.

To investigate the influence of temperature on the rhythmic coordination of PS bursts, we used extracellular electrodes to record from each ganglia the posterior branch of nerve 1, which host the axons of the PS motoneurons. Our experiments were performed with an isolated nerve cord, without sensory input, in normal environmental temperature conditions and two extreme conditions. Therefore we applied saline with different temperatures: cold at 9°C, middle at 19°C (room temperature) and warm at 26°C. Afterwards we analyzed the rhythm, to determine how it reacted on different temperatures and how temperature fluctuations influence the coordination and other parameters of the PS bursts.

The on-set of each PS burst stayed stable during the experiments and was not influenced through different temperatures (PS5 = 0, PS4 = 0.24 ± 0.03, PS3 = 0.48 ± 0.05, PS2 = 0.71 ± 0.06). There was also no effect on the off-set of these bursts (PS5 = 0.4 ± 0.06, PS4 = 0.63 ± 0.07, PS3 = 0.95 ± 0.05, PS2 = 1.18 ± 0.07). The duration, the period as well as the intensity of the PS bursts on the other hand were influenced by environmental changes. Duration of PS bursts decreased with increased temperatures. PS5 burst duration dropped from 0.3 ± 0.06s at 9°C to 0.2 ± 0.04s at 26°C. The effect on the period was similar and it decreased from 0.7 ± 0.08s at 9°C to 0.5 ± 0.05s at 26°C. A raise in temperature caused a decline in intensity of PS bursts.

Our experiments demonstrate, that the coordinated rhythm with the characteristic progression from posterior to anterior is robust against temperature fluctuations from 9 to 26°C and that the neural circuit is able to maintain function. But with increase in temperature the duration and period decreased, the powerstroke burst intensity decreased while the phase lags remained constant.

Calcium imaging of retrogradely labeled retractor coxae neurons in the stick insect *Carausius morosus*

Jens Goldammer, Cathleen Rotte¹, Joachim Schmidt¹, Peter Kloppenburg¹, Ansgar Büschges¹

¹ University of Cologne, Department of Animal Physiology, Zùlpicher Str. 47b, 50674 Köln, Germany

Calcium ions (Ca^{2+}) play an important role in various neuronal processes, e.g. release of neurotransmitters or as 2nd messengers (for review see Berridge 1998). We are interested in the potential contribution of Ca^{2+} transients to rhythmic motor activity in stick insect leg motoneurons (MNs). Neuroanatomical data in the stick insect *Carausius morosus* showed that MN neurites are mainly found in dorsal ganglion regions, especially neurites of retractor coxae MNs that have axons in nervus lateralis 5 (nl5; Goldammer et al. 2012) and therefore are suited for calcium imaging studies.

We retrogradely labeled mesothoracic nerve nl5 with the Ca^{2+} sensitive dye Oregon Green 488 Bapta-1 dextran. Measurements of Ca^{2+} transients in retractor coxae MNs were combined with extracellular recordings of the antagonistic protractor coxae MNs or of the backfilled nl5, respectively. We induced either rhythmic activity in the MNs through application of the muscarinic receptor agonist pilocarpine (Büschges et al. 1995) onto the mesothoracic ganglion or activity was induced by tactile stimulation of the animal. Our results show spatially uniform Ca^{2+} transients in primary neurites and higher order branches in antiphase with the activity of excitatory protractor coxae MNs (N=5) and in-phase with activity of the labeled nl5 MNs (N=3). Currently we are investigating the role of Ca^{2+} transients in mediating the tonic depolarization of MNs during walking movements.

GABAergic innervation of the ciliary ganglion in pigmented and albino rats

Miriam Barnerssoi, Anja K.E. Horn¹

¹Institute of Anatomy and Cell Biology I, LMU Munich, Germany

The ciliary ganglion (CG) of vertebrates contains postganglionic neurons that are activated from cholinergic preganglionic neurons in the Edinger-Westphal nucleus (EWpg) to mediate pupillary constriction and lens accommodation. For that the cholinergic postganglionic neurons in the CG target two inner eye muscles, the sphincter muscle (pupil) and the ciliary muscle (accommodation). Recent studies in bird and monkey have shown that apart from the cholinergic and a neuropeptidergic input the CG receives a considerable GABAergic input. According to these studies 50,9 % of all CG postganglionic neurons in pigeon and 17,5 % in monkey receive a dense GABAergic input, which was shown to arise from the midbrain in the vicinity of the EWpg in monkey. However, the function of the GABAergic innervation of the CG and its possible role in pupillary constriction or lens accommodation is unclear.

In this study, we investigated the ciliary ganglia of three pigmented wildtype and three albino rats for the presence of GABAergic terminals and possible quantitative differences. Albinism is associated with a variety of ocular anomalies including the inability of the eye to focus on an object as its distance varies (accommodation) and photophobia due to a lack of melanin (not dysfunction of pupillary constriction) in the iris. Immunohistochemical stainings of frozen wildtype and albino CG sections for the GABA synthesizing enzyme, Glutamate Decarboxylase (GAD), revealed that a subpopulation of approximately 59,1 % of all CG neurons in the wildtype, but only 12,7 % in the albino rat receive a dense supply of GAD-positive terminals. The CG neurons associated with GAD-positive terminals did not show a preferred location within the CG, but were evenly distributed throughout the whole ganglion in wildtype and albino.

These results and the report that only 3 % of all ciliary neurons innervate the pupillary sphincter (Warwick R., 1954) suggest that the GABAergic input into the ciliary ganglion may contribute to pathways for lens accommodation, but not pupillary light reflex.

Supported by: DFG Research Training Group 1091, Klinikum Großhadern, Ludwig-Maximilians-University Munich, Germany

Characterization of Muscle Fiber Types in an Insect Leg

Elzbieta Godlewska, Ansgar Büschges¹, Matthias Gruhn¹

¹University of Cologne, Animal Physiology, Zùlpicher Str. 47b, 50674 Köln, Germany

Locomotion is based on movements of an animals appendages that arise from neural activity causing muscles to contract. Neuromuscular transformation can be considered as basic aspect of motor control. Studies of the neuromuscular control system in the stick insect *Carausius morosus* have helped to understand the generation of leg movements and have been used to generate realistic kinematic simulations (Guschlbauer et al. 2007; Hooper et al., 2007; v.Twickel et al. 2011). However, one of the major shortcomings of these simulations is the fact that they are based on detailed insights from one leg muscle, the *extensor tibiae* muscle, only. In the generation of the simulations these results have been extrapolated on the other leg muscles that contribute to leg movements. One important aspect of generalization concerns the contribution of different muscle fiber types to force generation. It has been known for a long time that the contraction properties of muscles correlate with the activity of enzymes such as the myofibrillar ATPase within its muscle fibers (see Stokes, 1987; for the stick insect *extensor tibiae* muscle see Bässler et al. 1996). Here, we report the histochemical analysis of mATPase activity in leg muscles responsible for the control of movements in all three thoracic segments of the animal (*protractor* and *retractor coxae*, *levator* and *depressor trochanteris*, *flexor* and *extensor tibiae*). mATPase activity measurements were conducted based on established protocols (Gruhn & Rathmayer, 2002; Bässler et al. 1996), and the number of fibers and the cross-sectional areas of each muscle fiber type were determined.

We show the presence of at least four different muscle fiber types in the leg muscles of stick insect (slow, two intermediate types and fast). The thoracic muscles (*protractor cx.* and *retractor cx.*) consist mostly of fast contracting muscle fibers, independent of the segment and the analyzed region (anterior or posterior) within the muscle. Slow contracting muscle fibers are the second major group, mainly present in the larger posterior part of the muscle. The majority of muscle fibers in both muscles of the coxa (*levator tr.* and *depressor tr.*) is again made up by fast fibers, while the number of slow muscle fibers is much smaller. The most prominent feature in the coxa is a "belt like" arrangement of slow muscle fibers in the depressor tr. Our data for the *extensor ti.* muscle largely reproduce the findings of Bässler et al. (1996): the number of slow fibers increases from proximal to distal, and the number of fast fibers decreases from proximal to distal, with the same being true for the *flexor ti.* Together with electrophysiological activation profiles and sarcomere and fiber length measurements, our complete mATPase profile of the stick insect leg muscles may add to better understand the neuromuscular control of stick insect leg movement.

Supported by DFG grant Bu857.

Body-Side Specificity of Descending Control of Leg Motor Activity during Turning in an Insect

Matthias Gruhn, Philipp Rosenbaum¹, Anke Borgmann¹, Ansgar Bueschges¹

¹University of Cologne, Biocenter, Dep.of Zoology/Animal Physiology, Zulpicher Str. 47b, 50674 Koeln, Germany

In the past decades the neural mechanisms underlying the generation of basic locomotor movements have been unraveled to a considerable extent resulting in a quite detailed picture on the organization and operation of those neural networks that underlie the generation of the basic motor activity for swimming, flying and walking. However, relatively limited insights exist into the generation motor flexibility. For example, while generation of forward walking in insects is quite well understood, the neural mechanisms underlying the flexibility of motor behaviors during behaviors such as curved or backward walking remain largely unknown (e.g. Bueschges & Gruhn, 2008).

Here, we investigated the neural mechanisms underlying curve walking in insects. We analyzed middle leg muscle activity of tethered, intact animals, walking freely on a slippery surface during optomotor induced curved walking (Gruhn et al., 2009a). No marked changes in cycle period, duty cycle distribution, or the average stepping frequency occurred with a change in function of the leg as outside (oL) or inside leg (iL). Activity and timing in the muscles innervating the two distal leg joints, i.e. the levator and depressor of the trochanter and the extensor and the flexor of the tibia were virtually the same between the two behaviors except for a small increase in flexor activity. However, the muscles of the thoracocoxal joint, the protractor and retractor of the coxa, occasionally reversed phasing of activity during inside steps. We then studied the influence of descending signals from rostral segments, including front legs, on mesothoracic coxal MN activity in the otherwise deafferented mesothoracic ganglion. During optomotor-induced turning with the front legs (N=17), the mesothoracic protractor and retractor neurons on the inside showed rhythmic alternating activity strictly coupled to front leg stepping similar to the situation in straight forward stepping, while they often generated tonic activity with rarely occurring rhythmic alternation on the outside. At the same time, protractor activity was much stronger in inside turning when compared to outside turning, while the opposite was true for retractor activity. Results of split bath experiments using the muscarinic agonist pilocarpine (N=5; Bueschges et al. 1995) and unilateral lesion of the connective anterior to the mesothoracic ganglion (N=5) support the notion of a task-dependent descending influence on the activity of mesothoracic central pattern generating networks underlying motor activity for oL and iL walking. Our results indicate that turning kinematics of single legs are under individual segmental control and that descending signals from the brain not only prime sensorimotor processing (Hellekes et al., 2012) but also central premotor networks in a hemi-segment and task-specific fashion to generate flexible locomotor behavior. Supported by DFG grant Bu857/10.

Control of motor activity in a walking stick insect (*Carausius morosus*) leg with and upon loss of ground contact

Joscha Schmitz, Volker Berendes¹, Michael Dübbert¹, Matthias Gruhn¹, Ansgar Büschges¹

¹University of Cologne, Animal Physiology, Zùlpicher Str. 47b, 50674 Cologne, Germany

For the coordinated movement of a leg during locomotion, it is essential that the muscles of the different leg segments are activated in clear phase relationships to one another. In the stick insect locomotor control system, much is known on the contribution of select afferent sensory inputs to activating the different motor neuron pools (see Büschges et al. 2008). However, even though it is known that activation of the *flexor tibiae* muscle is tightly coupled to touch down of the leg with latencies of often less than 10ms (Gruhn et al. 2006; Rosenbaum et al. 2010), the origin of that tight coupling remains unknown. We are using a newly developed trap door setup to investigate how afferent input signaling ground contact contributes to stance phase muscle activation in the stick insect *Carausius morosus*. The walking surface consists of a lubricated stainless steel surface that allows electronic tarsal contact monitoring (see Gruhn et al. 2006). One part of the platform can be lowered pneumatically and a thin sheet of laser light is then used to detect the time of fictive touch down. A 2-leg stick insect preparation was tethered above a slippery surface and EMG recordings were made from all six major leg muscles, the *protractor* and *retractor coxae*, *levator* and *depressor trochanteris*, *flexor* and *extensor tibiae*, and the *retractor unguis* (claw retractor muscle). Here we describe basic properties of the new setup, compare the onset of EMG activity in stance phase muscles between ground supported steps and steps without ground support. None of the timing of activation of the different leg muscles except for that of the *flexor tibiae* muscle is changed if the animal unexpectedly steps into a hole. For example activation of the *retractor coxae* under control conditions occurs 34 ± 32 ms (N=3, n=27) before touchdown as it does when the foot is entering the hole (33 ± 21 ms; N=3, n=9; detected by the laser sheet). In contrast, upon loss of ground, the latency between the fictive touchdown and the first *flexor tibiae* unit is significantly increased compared to control steps (latency ctrl.: 13 ± 10 ms; N=39, n=1352, vs. air step: 65 ± 45 ms; N=39, n=315).

We ablated individual force sensors, i.e. tibial and femoral campaniform sensilla (tiCS and feCS, resp.) on the leg. Whereas ablation of tiCS had no effect on the latencies in ground supported and air stepping (N=4, n= 11), ablation of the feCS significantly increased the latencies of both control steps (latency ctrl.: 11 ± 9 ms; N=5, n=45, vs. feCS ablated: 21 ± 18 ms; N=6, n=54) and air steps (latency ctrl.: 50 ± 32 ms; N=5, n=15, vs. ablated feCS: 97 ± 57 ms; N=6, n=18) 24 hours after the ablation. At the same time, removal of the tarsus causes a strong reduction of the variability in latency of flexor activation. Our results show that specific load feedback signals determine the timing of *flexor tibiae* activation at the swing-to-stance transition in stepping stick insects. Supported by DFG grant Bu857/11.

Calcium FRET-imaging indicates bilateral power balancing in transgene *Drosophila* flight muscle

Fritz-Olaf Lehmann, Dimitri Skandalis¹

¹University of Ulm, Institute of Neurobiology, Albert-Einstein-Allee 11, 89081 Ulm, Germany

Maneuvering flight in animals requires precise adjustments of mechanical power output produced by the flight musculature. In many insects such as *Drosophila*, flight muscle function is due to calcium preconditioning and stretch activation and resides in a thoracic shell that simultaneously drives both wings during wing flapping. Employing a genetically expressed muscle calcium indicator, we here demonstrate the ability of this animal to bilaterally adjust its calcium activation to the mechanical power output required to sustain aerodynamic and inertial costs during flight.

Muscle fiber-specific comparisons of calcium activation during lift modulation and yaw turning behavior suggest higher calcium activation for dorso-longitudinal than for dorso-ventral muscle fibers, which corroborates the elevated need for muscle power during the wings' downstroke. The bilateral control of muscle calcium runs counter to the hypothesis that the thorax of flies acts as a single, corporate source for mechanical power production for both flapping wings. Collectively, power balancing highlights the precision with which insects adjust their flight motor to changing energetic requirements during aerial steering.

Fig. 1. Muscle attachment sites of the indirect flight muscle on the inner cuticle. Relative YFP/CFP ratio (FRET) in a resting (left) and in a flying fly (middle). Data are plotted in pseudo-color and normalized to mean YFP/CFP ratio during rest. Flight-mediated increase in YFP/CFP ratio is similar to the increase caused by electrical stimulation of the A-IFM. FRET response to electrical stimuli applied via the giant-fiber pathway (right).

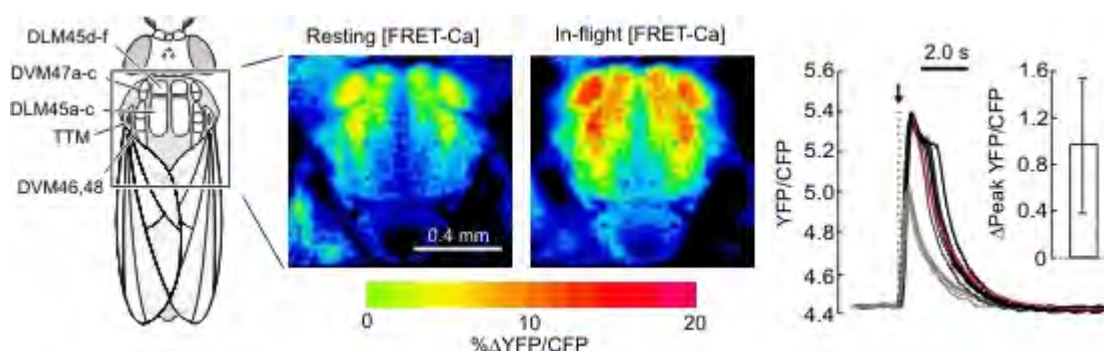

Control of handling food by the “hands” in insect feeding

Reinhold Hustert, Anh-Vu Nguyen¹

²¹Georg-August-Universität Göttingen, JFB-Institut f. Zoologie, Neurobiologie, Sensomotorik, Berliner Str. 28, 37073 Göttingen, Germany

Guiding food with hands or forelimbs to the mouth for biting off pieces is observed in many animals. It is a good example of kinesthetically guided coordination between different body parts, specifically object manipulations that require fine-tuned and adaptive sensory-motor coordination under mechanosensory (kinesthetic), haptic and often also under visual control. Mantids hold their prey for biting off pieces, just as some bushcrickets do. Locusts can hold a loose or dangling blade of grass vertical between the tarsi of both their forelegs and guide it to their mouthparts for biting off pieces. The legs position the food precisely for the mandibles and raise the grass blade during series of biting off with the mandibles with fine motor control. That presents a model for relative coordination with mainly the limbs controlling the behavior and it is also a model for bilateral haptic motor control between the forelegs. Myograms from foreleg muscles in partly restrained locusts demonstrate the positioning control of food pieces for the biting mandibles. Descending interneurons transfer the control commands to the foreleg motor centers in the prothoracic ganglion.



Single trial neuronal correlates of decision-making for hand grasping in macaque area F5 and AIP

Benjamin Wellner, Jonathan A Michaels¹, Wiebke Alexandra Wellner², Hans Scherberger¹

¹German Primate Center, Neurobiology, Kellnerweg 4, 37077 Göttingen, Germany

²Ernst Strüngmann Institute gGmbH, Deutschordenstraße 46, 60528, Frankfurt am Main, Germany

For the planning and execution of hand grasping movements, different brain circuits need to coordinate their activity, in particular when the brain needs to choose between multiple possible actions. To get insight in the neural dynamics during the decision process related to hand grasping, we recorded neuronal activity in the anterior intraparietal area (AIP) and in the ventral premotor cortex (area F5) while two macaque monkeys were either instructed to grasp an object with one of two possible grip types or could freely choose between both grasping options.

Monkeys were trained to grasp a handle with either a power grip or a precision grip to receive a reward. Trials started after the animal placed both hands on resting positions and fixated a red fixation light on a screen (fixation period). After 600 to 1000 ms, a second light was shown next to the red light to instruct the monkey about the required grip type (cue period). In the instructed task, either a green or a white light appeared for 300 ms, indicating to perform a power grip or precision grip, respectively. In the free-choice task, both the green and white light were illuminated, indicating that the monkey was free to choose between the two grip types. After that, the monkey had to memorize the instruction for 400 to 600 ms (first memory period). Then, in 50% of all free-choice trials the green or white light re-appeared for 300 ms, which turned the free-choice task into an instructed task, which was followed by a second memory period (duration: 400 to 600 ms). In all other trials only the red fixation light was shown, which made it impossible to distinguish the first from second memory period. By switching off the fixation LED, the monkey was then instructed to reach and grasp the target (movement period) in order to receive a liquid reward. Importantly, during free choice trials the reward was reduced every time the monkey repeatedly chose the same grip type. All trials were presented randomly interleaved and in total darkness.

Using permanently implanted electrodes in AIP and F5, we recorded single-unit activity simultaneously from 128 channels while the animals performed this task (monkey S: 20 sessions, monkey Z: 10 sessions). We found that ~70% of all single units were tuned for grip type in F5 and ~60% in AIP. Significant differences between free choice and instructed trials (task type) were present in ~20% of cells. Interestingly, there was no significant difference between free choice and instructed trials (task type) during the movement epoch, but ~30% of the neurons were tuned differently during previous epochs. After reward onset ~25% of the cells were task-type tuned in both areas. By comparing trials with different rewards we could demonstrate that this effect was due to inherent reward tuning. Furthermore, using single trial neural population analysis with a Bayesian decoder and Gaussian process factor analysis (GPFA), we could demonstrate that the neural population first splits up for the different task condition, whereas later in the task only the two grip types remain separated, indicating that late in the memory period and during the movement epoch the task condition is not represented anymore.

In summary, AIP and F5 were clearly modulated by the different task types, suggesting that these areas are part of a decision network for hand grasping.

Embodied Joint Movement Control: Interaction of Neural Networks and Passive Muscle Properties in the Stick Insect

Arndt von Twickel, Christoph Guschlbauer¹, Charalampos Mantziaris¹, Anna Schwarz¹, Ansgar Büschges¹

¹University of Cologne, Dept. of Animal Physiology, Zùlpicher Str. 47b, 50674 Cologne, Germany

²Nobel Institute for Neurophysiology, Dept. of Neuroscience, Karolinska Institutet, SE-171 77 Stockholm, Sweden

Taking a morphological modeling approach to the control of stick insect walking, i.e. incorporating knowledge on biomechanics and neural network structure and dynamics, reveals shortcomings in the available data used to construct the model. Here, we demonstrate how this modeling approach led us to examine the passive dynamic muscle properties of the stick insect flexor tibiae muscle and its interaction with the active properties of its antagonist, the extensor tibiae muscle. Unactivated muscle stretch experiments reveal complex passive dynamic force responses of the flexor tibiae muscle that not only show a nonlinear dependency on movement velocity but also on joint position and acceleration. When incorporated into our morphological model, this allows simple neural control systems to generate very fast, yet stable swing movements. In previous (functional) modeling studies without or with simpler muscle models more complex neural control was required or natural kinematics and dynamics could not be reproduced. Our results demonstrate that the passive muscle bears the potential to act like an instantaneous, intrinsic stabilizer of joint movement – a contribution of biomechanics to movement control which has been termed "preflex" (see Full and Koditschek, 1999). Preliminary results suggests that an extension of the intra-joint view on passive and active muscle property interactions with neural control to inter-joint and inter-leg interactions reveals even more biomechanical contributions to the control of walking movements in stick insects. Particularly the thorax-coxa joint demonstrates that passive joint properties between legs can be very heterogeneous.

Allocentric planning of immediate reach movement is prone to induced Roelofs illusion

Bahareh Taghizadeh, Alexander Gail^{1,2}

¹German Primate Center

²Bernstein Center for Computational Neuroscience

The visual perceptual localization of an object often is more prone to illusions than an immediate visuomotor response towards that object. Such findings have been taken as evidence for two independent functional visual processing streams, a ventral “vision-for-perception” pathway, and a dorsal “vision-for-action” pathway (Goodale and Milner, 1992). The induced Roelofs effect (IRE) probes the illusory influence of task-irrelevant visual context stimuli on the processing of task-relevant visuospatial instructions during movement preparation. In the IRE, the position of a task irrelevant visual object induces a systematic shift in the localization of the visual target object. This is true when subjects have to indicate the position of the target object relative to an array of reference positions, e.g. by using response keys, or by pointing to the target object with delay. In contrast, when subjects in the same task indicate the position of the target object by immediately pointing to it (without instructed delay), or by directly reaching towards it with or without delay, no IRE is induced. This discrepancy had originally been taken as evidence for the dual-visual-stream hypothesis (Bridgeman et al., 1997), and later was explained by a dynamic distortion of the egocentric spatial frame of reference which is centered on the subjective straight-ahead and in which reaches are planned (Dassonville and Bala, 2004). Here we ask if the IRE in fact depends on a distorted egocentric frame of reference, or if it also occurs during allocentric reach planning.

We asked human subjects to perform reaches towards visual target stimuli in the frontoparallel plane. Each trial started with a brief appearance of a reference array (RA) of five horizontally arranged boxes which indicated the potential target positions. Then the target and a surrounding task-irrelevant visual frame were flashed, followed by a decision array (DA) immediately after the cue/frame offset. The DA was identical to the RA, but could be placed at different positions on the screen. While keeping ocular fixation, subjects had to reach towards the DA box which corresponded to the RA box in which they had seen the flashed target.

The results showed a reliable IRE for immediate reach movements that could not be explained by either of the previous hypotheses. In our task the reach goal needed to be defined relative to a task-relevant object, i.e. in an allocentric (object-based) reference frame. The results suggest that during allocentric encoding of motor goal locations, the information of additional task-irrelevant objects can induce systematic mis-localizations of the reach goal. Our finding argues against strictly separate visuospatial representations for direct sensorimotor processing compared to spatial cognitive processing.

Reference List

- Bridgeman B, Peery S, Anand S (1997) Interaction of cognitive and sensorimotor maps of visual space. *Percept Psychophys* 59:456-469.
- Dassonville P, Bala JK (2004) Perception, action, and Roelofs effect: a mere illusion of dissociation. *PLoS Biol* 2:e364.
- Goodale MA, Milner AD (1992) Separate visual pathways for perception and action. *Trends Neurosci* 15:20-25.

Interdependence of movement planning and choice behavior for decisions among multiple reach goals

Lalitta Suriya-Arunroj, Alexander Gail^{1,2}

¹Sensorimotor Group, Deutsches Primatenzentrum, Göttingen, Germany

²Bernstein Center for Computational Neuroscience, Göttingen, Germany

When we are free to choose among multiple behavioral options, the available response alternatives are weighed against each other until the decision is reached. According to an emerging view, the neuronal mechanisms of decision making are tightly entangled with the neural mechanisms of motor planning (Cisek & Kalaska, 2010). This view predicts that decision making and motor planning should be interdependent. Regarding multiple decision making criteria, our choice is influenced not only by the objective costs and benefits that are associated with the different options, but can also be biased by other factors, which might help to speed up decisions, while at the same time preventing rational choice (Evans, 2003). Here we investigate whether the preliminary planning of a movement interferes with free-choice decision making. Specifically, we asked if movement planning can induce choice-biases independent of objective costs or benefits when a preliminary planned movement overlaps with one of the potential action choices in a free-choice situation.

We asked subjects to perform memory-guided center-out reaches towards previously instructed target positions on a touch screen. The correct target had to be determined from two instructive cues. A pre-cue consisted of two differently colored triangles which appeared at one of the four cardinal directions from the center and which pointed to two opposite (clockwise-counterclockwise) directions. The pre-cue indicated, first, the locations of two possible targets in that given trial which were located at either 90° clockwise and 90° counterclockwise to the position of the pre-cue. Second, the size of each triangle represented the different probabilities of each target to be instructed by the context cue at the end of the trial. After a memory period, a spatially neutral context cue was presented, which could be color-neutral (white, uninstructed 'free-choice' trial) or equal-colored to one of the two colors of the pre-cue triangles (instructed trial). In case of the colored context cue only the target which corresponded to the equal colored triangle of the pre-cue was rewarded. In case of the white context cue both available targets were rewarded with a fixed equal probability of 50%, completely independent of the size of the pre-cue or any previous choice response.

Results showed that indicating to the subjects by the size of the pre-cue which instructed motor goal will be more likely, and hence encouraging planning the respective movement, had a significant effect on the subjects' choice of action in the free-choice trials. The effect was observed even though the reward probability in free-choice trials was independent of the probability with which the one or the other response alternative was instructed in the instructed trials. Also, the reaction time analysis suggested that the more biased the subjects were towards a target, the faster they reached to it. Our results provide behavioral evidence that movement planning and decision making are interdependent, thereby supporting the idea that the underlying neural mechanisms overlap.

References:

- Cisek P, Kalaska JF (2010) Neural mechanisms for interacting with a world full of action choices. *Annu Rev Neurosci*, 33, 269-98.
- Evans JS (2003) In two minds: Dual process accounts of reasoning. *Trends in Cognitive Sciences*, 7,

Activity of DUM Neurons in the Subesophageal Ganglion during Locomotor Behavior in the Stick Insect

Thomas Stolz, Martin Heß², Joachim Schmidt¹

¹University of Cologne, Department of Animal Physiology, Zùlpicher Str. 47b, 50674 Cologne, Germany

²University of Cologne, Department of Genetics, Zùlpicher Str. 47a, 50674 Cologne, Germany

Octopamine is a key player in insect motor control. Efferent thoracic DUM neurons are known to be the source of octopamine peripherally modulating neuromuscular transmission, muscle contraction kinetics, sensory sensitivity and muscle metabolism (for review: Bräunig & Pflüger, 2001). The neurons mediating central octopaminergic effects in contrast have remained elusive. However, there is a group of octopaminergic DUM neurons with cell bodies in the posterior part of the subesophageal ganglion (SEG) and axons descending into the ganglia of the ventral nerve cord (see Stevenson & Spörhase-Eichmann, 1995; Bräunig & Burrows, 2004). Due to their projection pattern these neurons are putative candidates contributing to the central octopaminergic modulation of motor circuits.

Here we used semi-intact preparations of the stick insect *Carausius morosus* in order to substantiate the descending SEG DUM neurons suggested involvement in locomotor pattern generation. The presence and location of the neurons in the SEG of the stick insect was confirmed by retrograde labeling. Additionally, simultaneous intracellular recordings from those descending SEG DUM neurons and extracellular recordings from connectives showed that the neurons conducted soma spikes at least caudal to the prothoracic ganglion.

We studied whether and how these cells were activated by mechanosensory stimulation and single leg stepping movements using a semi-intact walking preparation. Intracellular recordings revealed that the descending SEG DUM neurons were depolarized and elicited action potentials when the abdomen was stimulated, the intact middle leg was moved passively or was stepping on a treadmill. Based on differences in the neurons activation and diverging intrinsic properties two functional neuron types could be distinguished.

The above mentioned results indicate that descending SEG DUM neurons receive depolarizing drive related to locomotor behavior in the mesothoracic ganglion. This finding raised the question whether their activity might in turn contribute to the modulation of central pattern generators within thoracic ganglia. In order to address this question the effect of SEG DUM neuron activity on pilocarpine-induced rhythmically alternating bursting of protractor and retractor coxae motoneurons was analysed. First experiments indicate that neither cycle durations and burst durations nor the recruitment of single units within the bursts were influenced by evoking high frequency spiking in descending SEG DUM neurons.

Calretinin inputs are confined to motoneurons for upward eye movements in primates

Christina Zeeh, Bernhard J. Hess², Emmanuel Chen Ngwa³, Julia M. Feige³, Anja K.E. Horn^{1,3}

¹German Dizziness/Vertigo Center, University Munich, Institute of Anatomy, Oculomotor Group, Pettenkoferstr. 11, 80336 Munich, Germany

²Vestibulo-Oculomotor Laboratory Zürich, Dept of Neurology, Zürich University Hospital, Frauenklinikstr. 26, 8091 Zürich, Switzerland

³Institute of Anatomy and Cell Biology, Department I, LMU Munich, Germany

For the generation of different eye movements the motoneurons of extraocular muscles are controlled by separate premotor pathways, which may be affected selectively in certain eye movement disorders. There are specific disorders for the vertical eye movement system that affect only one direction, e.g. isolated upgaze or downgaze palsy or upbeat or downbeat nystagmus, which indicate that up- and downgaze pathways are organized in a different way.

With combined tract-tracing and immunofluorescence staining the motoneuronal groups of vertical-pulling eye muscles in the monkey trochlear and oculomotor nucleus were investigated for the presence of afferent terminals containing the calcium-binding protein calretinin. This protein had been found in premotor neurons involved in vertical gaze (Ahlfeld et al., 2011). The analysis revealed that in the oculomotor nucleus calretinin was specifically found in axonal profiles contacting motoneurons of the superior rectus (SR) and inferior oblique muscle (IO), both mediating upward eye movements. In addition a strong labelling was present in the central caudal nucleus (CCN) containing the motoneurons of the levator palpebrae muscle (LP), which participate in upward eye movements as well. Double-immunofluorescence labelling revealed that the calretinin-positive terminals lacked the GABA marker glutamate decarboxylase (GAD) present in afferents to all motoneurons mediating vertical eye movements and therefore the calretinin-positive terminals are considered as excitatory afferents. Similarly, immunostaining for calretinin on human midbrain sections revealed selective terminal labelling in the CCN and a central group in the oculomotor nucleus, which corresponds to the SR and IO subgroup in monkey (Zeeh and Horn, 2012). Accordingly, the motoneurons for up- and downgaze were identified and analysed for degeneration in a post-mortem analysis of six patients with progressive supranuclear palsy (PSP), who had shown different states of a vertical gaze palsy.

Knowing that the inhibitory premotor pathways for horizontal and vertical eye movements differ in their transmitters, glycine is used in the horizontal system, GABA in the vertical system, the present work adds specific histochemical properties to a further premotor pathway. Since not all premotor upgaze pathways, for example the secondary vestibulo-ocular neurons, contain calretinin, the protein may be confined to a subpopulation of premotor upgaze pathways, such as the saccadic or smooth pursuit system. The functional significance of calretinin in these connections is unclear, but the protein may serve as useful marker to locate upgaze pathways in the human brain enabling correlative clinico-anatomical studies on cases with upgaze deficits, such as PSP.

Ahlfeld J, Mustari M, Horn AKE. 2011. Sources of Calretinin inputs to motoneurons of extraocular muscles involved in upgaze. *Ann N Y Acad Sci* 1233:91-99

Zeeh C, Horn AKE. 2012. Der Okulomotoriuskern und seine Subnuklei beim Menschen.

Klin Monatsbl Augenheilkd 2012; 229:1-7

Grant support: DFG

BMBF (German Dizziness Center, IFB) 01 EO 0901

Neural control of forward and backward walking in insects

Philipp Rosenbaum, Ansgar Bueschges¹

¹University of Cologne, Department of Animal Physiology, Zulpicher Str. 47b, 50674 Köln, Germany

The neural basis for walking movements in insects is understood to a quite detailed extent, specifically for the single leg control in forward walking (Büschges et al. 2007). However, present knowledge is still limited about the neural control of adaptive locomotor behaviors, like curved walking and backward walking. Previous studies of the muscle activity in an stick insect freely walking forward and backward on a slippery surface reported the most pronounced changes in the muscles controlling the Thorax-Coxa-(ThC-) joint, i.e. the retractor and protactor coxae muscles moving the leg in forward and backward direction, whereas activity of the muscles supplying the Coxa-Trochanter (CTr-) joint and the Femur-Tibia (FTi-) joint showed no difference (Rosenbaum et al. 2010).

Here, we aimed to study the specific synaptic drive the leg motoneurons, and especially coxal motoneurons (MNs), receive during forward as compared to backward stepping. Intracellular recordings and stainings of leg MNs and premotor non-spiking interneurons (NSIs) were performed in a single-leg preparation, in which the single middle leg is only able to move in the plane perpendicular to the thorax and for which we can show that 'fictive forward and backward walking', indicated by the motor activity of the coxal MN pools, could be reliably elicited by tactile stimulation of the animal's head and abdomen. We can show that leg muscle MNs receive the same synaptic input during forward as during backward walking, that means they are tonically depolarized and receive phasic inhibition and excitation according to their role in the step cycle.

We further studied the role of the NSIs providing synaptic drive to the leg motoneurons during the two different walking directions. NSIs are known to be important premotor elements integrating signals from other segments and local sense organs (Büschges, 1990; von Uckermann & Büschges 2009). Here, we describe the physiology and morphology of NSIs during forward and backward walking, and show that identified NSIs of the FTi-joint as well as NSIs controlling movements of the CTr-joint do not change their activity pattern during the different walking directions. However, newly identified NSIs involved in the control of the Thorax-Coxa-joint are differently modulated during forward walking and backward walking.

Whole-cell recordings from mouse forelimb motor cortex neurons during targeted reaching.

Birgit Christina Voigt, Luc Estebanez^{1,2}, James F.A. Poulet^{1,2}

Max Delbrück Center for Molecular Medicine Berlin Buch, Berlin, Germany

1

NeuroCure Cluster of Excellence, Berlin, Germany²

Primary motor cortex (M1) controls voluntary movement. While a number of studies have documented extracellular recordings during motor tasks, there is very little data available on the synaptic activity underlying motor processing in M1. Here we present whole-cell recordings from forelimb primary motor cortex (fM1) in mice trained to perform a forelimb reach and touch task. To locate fM1 we performed electrical microstimulation in anaesthetised mice and, in good agreement with previous studies, found fM1 centered 0.3 mm anterior and 1.6 mm lateral to bregma. Up to 6 head-restrained mice were trained in parallel within 6-10 days to reach and touch a sensor. Pharmacological inactivation experiments with cortical microinjections of the GABA-A receptor agonist muscimol confirmed that the behaviour was dependent on fM1 activity. Whole-cell recordings from fM1 in awake, behaving mice revealed strong state-dependent changes in subthreshold activity. Large amplitude, slow oscillations were present during quiet periods. During active reaching, by contrast, smaller amplitude, higher frequency, depolarised synaptic input prevailed. All neurons showed a modulation in membrane potential during reaching at different phases of the reach. Layer 2/3 neurons showed significantly larger subthreshold modulations than layer 5 neurons. We hypothesise this is the result of sensory feedback targeting upper cortical layers in M1.

Modulation in the processing of movement signals from the leg during curve walking of an insect

Katja Hellekes, Ansgar Büschges²

^{1,2}Biocenter, University of Cologne, Department of Animal Physiology, Zülpicher Str. 47b, 50674 Cologne, Germany

The generation of task-dependent and goal-directed walking behavior requires feedback from leg sensory organs for regulating and adapting the ongoing motor activity. In a variety of vertebrates and invertebrates, the effects of sensory input during walking differ from those seen in postural control. Commonly, these changes occur as reflex reversals (Forssberg et al. 1975; Bässler, 1975). The generation of reflex reversals frequently depends on the behavioral state of the animal (Büschges and El Manira, 1998; Clarac et al. 2000; Pearson, 1993). In stick insects that generate active movements with their legs, for example, flexion of the femur-tibia (FTi) joint, measured by the femoral chordotonal organ (fCO), mediates reinforcement of the stance phase motor output of the FTi joint. Thus, flexion signals promote flexor and inhibit extensor motoneuron activity, which reflects the activity pattern of the tibial motoneurons during a reflex reversal (Bässler, 1988). Previously, we have shown in an optomotor-induced curve walking paradigm, that reflex reversal in tibial motoneurons upon flexion signals from the fCO occurred reliably in the middle leg on the inside of the turn (inner leg, iL). In contrast, on the outside of the turn (outer leg, oL) we found this effect only rarely (Hellekes et al 2012).

In the present study, we focused on the analysis of neural mechanisms contributing to this task dependent difference in sensorimotor processing of movement signals in the curve walking animal. In the stick insect *Carausius morosus* the mesothoracic fCO was mechanically stimulated and the motoneuronal responses in the flexor and extensor tibia were monitored, while the remaining legs performed curve walking on a slippery surface. Additionally, we recorded intracellularly from premotor interneurons and motoneurons of the FTi joint control network.

First, in general there was a shift in membrane potential in tibial motoneurons depending on the function of the leg, i.e. iL or oL, in the curve walking insect. For example, in the oL extensor tibia motoneurons (N=7) were tonically depolarized as compared to rest, while in the iL the flexor tibiae MNs (N=7) were depolarized. Second, nonspiking premotor interneurons of the tibial motoneurons, known to be involved in the premotor network of the FTi joint in restrained preparations as well as during single leg stepping (comp. Büschges 1990; von Uckermann & Büschges, 2009), also contributed to the control of tibial motoneuron activity during curve walking both for the iL and the oL (N=10). Finally, initial experiments suggest that the contribution of individual nonspiking interneurons during fCO elongation in the iL reflects the known role during reflex reversal in the restrained animal (Driesang and Büschges 1996). Currently, we are analyzing the processing of fCO signals with specific reference to the oL. Supp. by DFG grant Bu857/10.

Immunocytochemical studies on the nervous system of Onychophora (velvet worms): insights into the evolution of arthropod body segmentation

Georg Mayer, Hans-Joachim Pflüger², Paul Anthony Stevenson³

¹University of Leipzig, Animal Evolution & Development, Institute of Biology, Talstraße 33, D-04103 Leipzig, Germany;

²Neurobiology, Institute of Biology, Freie Universität Berlin, Königin-Luise-Str. 28-30, D-14195 Berlin, Germany;

³Physiology of Animals and Behaviour, Institute of Biology, University of Leipzig, Talstraße 33, D-04103 Leipzig, Germany.

Due to their phylogenetic position as the sister group of Arthropoda, studies on the organisation of the nervous system in Onychophora will play a key role for understanding the evolution of body segmentation in arthropods. Recent immunocytochemical studies revealed that, in contrast to the arthropods, neurons containing the amine serotonin do not show a serially repeated arrangement, suggesting that segmentation is either reduced or incomplete in the onychophoran central nervous system. To assess how many segmentally repeated components are present in the onychophoran nervous system, we have screened the onychophoran nerve cords for various markers, including acetylcholinesterase, gamma-aminobutyric acid, synapsin, RFamide, dopamine, histamine, serotonin, tyramine and octopamine. In addition, we performed retrograde fills of serially repeated nerves to localise the position of neuronal somata supplying these nerves. Our data show a mixture of segmental and non-segmental elements in the onychophoran nervous system, suggesting that the segmental ganglia of arthropods evolved by a gradual condensation of subsets of neurons. These findings are in line with the hypothesis of gradual evolution of segmentation in panarthropods.



Network dependent activation of a hyperpolarizing conductance in motoneurons enhances neuronal synchrony

Boris P. Chagnaud, Andrew H. Bass²

¹Ludwigs Maximilians Universität München, Department II, Grosshadernerstr 2, 82152 Martinsried, Germany

²Cornell University, Department of Neurobiology and Behavior W239 Seeley G. Mudd Hall
Ithaca, NY 14853, USA

Synchronous firing coordinates the activity of neurons within and across neuronal populations and is thus essential to brain function. Using *in vivo* intracellular recordings in gulf toadfish (*Opsanus beta*) we show that a set of intrinsic and network properties, especially a voltage dependent potassium conductance, activated only upon network activity, generates a physiological gap of reduced probability of motoneuron activation leading to increased synchrony. As in midshipman fish (*Porichthys notatus*), individual, neurobiotin-filled vocal motoneurons exhibited modest dendritic arbors extending bilaterally throughout and lateral to the paired midline motor nuclei. Motoneurons lacked spontaneous activity, only firing action potentials at high frequencies matched to excitatory input from upstream vocal pacemaker neurons and concurrent with each distinct spike of a vocal nerve volley that directly determines natural call frequency and duration. Intracellular current injections revealed low somato-dendritic, voltage-dependent excitability with rapid accommodation of action potential frequency to current steps. Antidromic activation of motoneurons via the vocal nerve, including collision tests with intracellularly evoked action potentials, provided evidence for electrotonic coupling. Action potentials showed a strong after-hyperpolarization during vocal activity, while intracellular chloride injections revealed a background membrane hyperpolarization blocked by extracellular injections of bicuculline, a GABA_A receptor antagonist. A pharmacologically identified voltage dependent potassium conductance, not as evident in midshipman fish, led to a gap of reduced probability of motoneuron activation during vocal activity and after antidromic vocal nerve stimulation. This conductance, together with motoneuronal intrinsic and network properties, namely a strong inexcitability upon intracellular current injection, gap junctional coupling, phasic excitatory and tonic inhibitory input, leads to an extreme level of neuronal synchrony.

Spinal corollary discharge in mechanoreceptor-related nerves mediates information about locomotor activity

Roberto Banchi, Boris P. Chagnaud¹, Hans Straka¹

¹Ludwigs Maximilians Universität München, Department II, Grosshadernerstr 2, 82152 Martinsried, Germany

Intricate consequences of animal locomotion are undesired perturbations of sensory systems. Reafferent stimulation affects e.g. visual perception if not counteracted by appropriate visual fixation or reflexes that cause gaze stabilization. To compensate the consequence of reafferent signaling during self-induced motion, corollary discharges from the spinal locomotor pattern generator potentially inform sensory and motor systems about impending reafferent stimulation. The interaction between the feed-forward locomotion-related signals and the resulting movement driven sensory feed-back might occur at different single or multiple sites of sensory-motor pathways. Here, we show that a locomotor efference copy, which has been recently shown to stabilize gaze during swimming in larval *Xenopus laevis* potentially modulates the sensitivity of lateral line and vestibular afferents via mechanoreceptor-related efferent neurons projecting to the sensory periphery. Multiple- and single unit activity were recorded from the cut end of vestibular and lateral line nerve branches along with the spinal ventral roots discharge during spontaneous fictive swimming in a whole-head spinal cord in vitro preparation of larval *Xenopus*. The temporal correlation between the vestibulo-lateral line nerve discharge and the ventral root activity revealed rhythmic activation of efferent neurons, timed to the locomotor behavior. Calcium imaging of single efferent neuronal somata in the hindbrain during fictive swimming confirmed the coupling of the respective nerve activity. Rhythmicity was out of, and in phase, with contralateral and ipsilateral ventral spinal root activity, respectively. Thus, both main parameters of locomotion, i.e. frequency and duration are represented in the corollary discharge observed in the sensory nerve. Since efferent neurons modulate the gain of the sensory transmission in the periphery, the locomotor-efferent discharge coupling allows tuning the gain of mechanoreceptor afferent sensory input. To study the consequences of the locomotor-related efferent activity on the vestibular sensory periphery, we employed in vitro preparations of Axolotl (*Ambystoma mexicanum*). Recordings of the discharge of afferent fibres that innervate vestibular endorgans in the intact otic capsule were performed during simultaneous electrical stimulation of the efferent nucleus or during episodes of fictive locomotion. In summary, our results demonstrate that a spinal corollary discharge is directed to the efferent nucleus and that, by means of efferent activation, the sensitivity of mechanoreceptors in the periphery is decreased or even canceled in order to eliminate undesired sensory perturbations during active motor behavior, compatible with the suppression of horizontal angular vestibulo-ocular reflex during fictive swimming.

Encoding of intended reach movement direction in Local Field Potential Phase in monkey fronto-parietal reach area PRR.

Pablo Martinez-Vazquez, Alex Gail^{1,2}

¹Deutsches Primaten Zentrum, AKN, Kellnerweg 4, 37077 Göttingen, Germany²Bernstein Center for Computational Neuroscience, Göttingen, Germany

The spiking activity of neurons in the parietal reach region (PRR) is typically highly selective for the direction of a planned reach movement. For a large-enough population of motor-tuned neurons, the preferred movement direction (PD: direction of highest firing rate) of the individual neurons cover the full range of possible directions [1]. Thus, any reach direction can be decoded from the population response equally well. This is a useful property for the design of neuroprosthetic devices, but long-term recording of isolated single neurons is challenging.

Local field potential (LFP), on the other hand, represent the activity of a wider range of tissue, and are less sensitive to small electrode displacements or glial tissue growth, making them a more stable and putatively attractive source of information for decoding systems. LFP power in PRR also has been shown to be spatially selective [2-5]. However, LFP power shows substantial tuning similarities across separate recording channels, even if the corresponding electrodes are several hundred micrometers apart. These signal correlations reduce the information content of the population data significantly. In this study we test if LFP phase in PRR contains additional independent information about movements that monkeys planned to make into one out of eight reach directions according to previous visual instruction. We analyzed if phase differences between pairs of LFP signals were selective for the direction of the planned movements.

Our preliminary results indicate that not only LFP power, but also LFP relative phases exhibit directional tuning during movement planning. While tuning based on LFP amplitude shows highly similar PD values across channels, the relative LFP phases seem to provide more distinct PD values with less signal redundancy across multiple recording channels. This means, LFP phase contains information about planned movements which is not captured by LFP power, and which could thereby improve decoding performance for neuroprosthetic applications.

1. Gail A, et al (2006) Neural Dynamics in Monkey Parietal Reach Region Reflect Context-Specific Sensorimotor Transformations. *J Neurosci* 26: 9376-9384
2. Markowitz DA, et al. (2011) Optimizing the decoding of movement goals from local field potentials in macaque cortex. *J Neurosci*. Dec 14;31(50):18412-22
3. Scherberger H, et al. (2005) Cortical local field potential encodes movement intentions in the posterior parietal cortex. *Neuron* 21;46(2):347-54.
4. Donoghue JP, et al. (1998) Neural discharge and local field potential oscillations in primate motor cortex during voluntary movements. *JN Physiol* . Vol. 79 no. 1 159-173
5. Denker M, et al. (2007) Phase synchronization between LFP and spiking activity in motor cortex during movement. *Neurocomp* 70 2096–2101

Extrinsic and intrinsic factors influencing spontaneous and reinforcement-induced pitch changes in zebra finch song

Anna Ewa Stepien, Alessandro Canopoli¹, Alexei Vyssotski¹, Valance Yanxin Wang¹, Gagan Narula¹, Richard Hahnloser¹

¹ Institute of Neuroinformatics, ETH/University of Zurich, Zurich, Switzerland

Juvenile zebra finches learn their song from a tutor, undergo a practicing period during which they display high variability in song structure and finally, in adulthood, sing a stable song that consists of several syllables produced always in the same sequence. Despite predominance of song stability, in adulthood the pitch of individual syllables tends to oscillate during the day. Also, modifications of pitch can be enforced externally using negative reinforcement, by presenting disturbing cues (loud noise) contingent on pitch: birds can change pitch to escape the punishment (noise). Our goal is to provide a comprehensive understanding of pitch variability and its dependence on intrinsic and extrinsic factors. We explore the relationship between daily pitch fluctuations and reinforced pitch changes and the dependence of pitch on brain temperature, on song practice, on song tempo, and on the observed pitch of other birds. We find circadian pitch fluctuations that show overnight discontinuities. Typical fluctuations consist of higher pitch in the morning and of lower pitch in the evening. These fluctuations correlate with brain temperature. Birds can escape from negative reinforcements over the course of days even though daily fluctuations point into the direction of increased punishment (birds shift pitch against the reinforcement gradient).

Characterization of octopaminergic unpaired median neurons in the suboesophageal ganglion of *Manduca sexta*

Jessika Erdmann , Hans-Joachim Pflüger ¹

¹Freie Universität Berlin, Institut für Biologie-Neurobiologie, Königin-Luise-Str. 28/30, 14195 Berlin, Germany

Octopamine is a major biogenic amine in the insect nervous system where it functions as a neuromodulator acting on glands, sense organs or muscles, as a neurohormone mobilizing carbohydrates or lipids or as a neurotransmitter. It is considered to play an important role in initiation and maintenance of motor programs and is released by two main populations of octopaminergic neurons: paired neurons that occur in the brain and some segmental ganglia and unpaired median (UM) neurons that can be found in all segmental ganglia but not in the brain. These neurons exhibit dorsally or ventrally located cell bodies with bilaterally symmetrical axons.

The segmental ganglia contain efferent UM neurons projecting into peripheral nerves and innervating peripheral targets. In contrast, the suboesophageal ganglion (SOG), a higher center for motor coordination, contains two populations of intersegmental UM neurons: ascending UM neurons innervating principal brain neuropils and descending UM neurons projecting towards the thoracic ganglia. At least some of them descend to the terminal ganglion with broad arborizations in each segmental ganglion.

Little is known about the sensory inputs, morphology and connectivity of these descending UM neurons. Therefore, we performed intracellular recordings and staining in combination with electrical stimulation of peripheral nerves of either the thoracic ganglia or the SOG in the larval tobacco hawkmoth *Manduca sexta*. We show that descending UM neurons exhibit either inhibitory or excitatory responses due to stimulation of the thoracic nerve 2a containing axons of several proprioceptors of the larval leg, e.g. the femoral chordotonal organ and hair sensilla. They also respond either with excitation or inhibition to stimulation of the mandibular, maxillar and labial nerve 2 suggesting different sensory inputs to the three larval descending UM neurons of the SOG. Our results also reveal inhibitory inputs from the maxillar, labial nerve 1 and thoracic nerve 1a containing axons of dorsal hairlike sensilla.

Additionally, we performed paired intracellular recordings of descending UM neurons in the SOG and motor neurons or interneurons of the thoracic ganglia to test for direct connections.

Synergy of motor control pathways for aerial steering in *Drosophila*

Ruben Andres Berthé, Peter Schützner¹, Fritz-Olaf Lehmann¹

¹University of Ulm, Institute of Neurobiology, Albert-Einstein-Allee 11, 89081 Ulm, Germany

Body posture control in animals typically relies on multiple, redundant motor pathways. Due to their complex functional interactions, motor pathways synergistically contribute to the animal's stability during rest and locomotor activity. Animals further benefit from redundant motor control systems due to an improvement in the animal's ability to fine tune locomotor forces during running, swimming and flying. Our study aims to understand the complexity and dependencies of motor pathways during flight of *Drosophila*, dissecting three major motor systems for flight control: the abdominal control pathway, leg steering behavior and locomotor forces produced by flapping wing motion. Changes in posture of abdomen and legs affect aerial steering in two ways: by changes in aerodynamic drag on the animal body and relocation of the animal's center of mass. These alterations produce moments around the three rotational body axes and also alter mass moments of inertia during maneuvering flight. To investigate pathway synergy, we simultaneously reconstructed body posture, abdominal-, leg- and wing motion in freely-flying animals with high speed and employed an aerodynamic framework to estimate instantaneous locomotor forces and moments. In contrast to previous hypotheses, we found that moments produced by legs and abdomen are negligibly small during flight and may not substantially contribute to posture control. Thus, motor pathways for leg and abdominal steering should not be considered as redundant control systems in *Drosophila*, but systems for locomotor fine control. Their benefits might lie in the ability to constantly modulate wing-induced forces that strongly vary throughout the stroke cycle. On a neurobiological level, this behavior potentially enhances visual faculty during maneuvering flight by a reduction of image blur on the fly's retina. The synergy of motor pathways in flight of fruit flies might thus reinforce the efficacy of the animal's sensory capacity, which is of advantage, for example, for early triggering of evasive flight maneuvers during aerial predation.

The development of tyraminergetic/octopaminergic neurons of *Drosophila* muscles integrated in an atlas

Konstantin Lehmann, Christina Zube¹, Stephan Sigrist¹, Carsten Duch², Hans-Joachim Pflüger¹

¹Freie Universität Berlin, Institute of Biology - Neurobiology, Königin-Luise-Str. 28/30, 14195 Berlin, Germany

²Johannes Gutenberg Universität Mainz, Institute of Zoologie, Colonel-Kleinmann-Weg 2 (SBII), 55128 Mainz, Germany

Most if not all larval and adult muscles in *Drosophila* are supplied by tyraminergetic/octopaminergic neurons. During metamorphosis the adult muscles are formed. Some groups of muscles are generated by using persistent larval muscles as scaffolds; others are constructed de novo by fusion of imaginal myoblasts. Although many larval muscles are degraded, the tyraminergetic/octopaminergic neurons persist during metamorphosis. It is unclear how these neuromodulatory neurons change during the various development stages with respect to dendritic and axonal morphology. In transgenes in which all tyraminergetic/octopaminergic were labeled by GFP (green fluorescent protein), we study the normal development in order to get a reference and to reveal normal variance. Thus, we generate an atlas for all development stages and trace the tyraminergetic/octopaminergic neurons from the larval state L3 through all pupal stages to the emerging adult fly. This knowledge will then allow us to study respective mutants.

Spatio-temporal organization of local field potential oscillations in the monkey motor cortex

Lyuba Zehl, Thomas Broschier², Alexa Riehle^{2,4}, Sonja Grün^{1,3,4}, Michael Denker¹

¹Institute for Neuroscience and Medicine (INM-6), Computational and Systems Neuroscience, Jülich Research Center, Jülich, Germany

²Institut de Neurosciences de la Timone (INT), UMR 7289, CNRS - Aix Marseille Univ., Marseille, France

³Theoretical Systems Neurobiology, RWTH Aachen Univ., Aachen, Germany

⁴RIKEN Brain Science Institute, Wako-Shi, Japan

The local field potential (LFP) is thought to reflect the activity of neurons in the vicinity of the recording electrode [1,2]. In primary motor (MI) and premotor (PM) cortex, LFP oscillations in the beta band are typically observed during motor preparation [3]. Recent studies suggest that on the millimeter scale the LFP reflects a dynamic propagation of neuronal activity [4-6]. Here, we study the spatio-temporal organization of oscillatory LFP activity in motor cortex using massively parallel LFP recordings during a delayed reach to grasp task. Two monkeys (*Macaca mulatta*) were trained to grasp, pull and hold an object with high force (HF) or low force (LF) using either a side grip (SG) or a precision grip (PG). After the monkey initiated the trial, either the grip or the force information was revealed as a visual cue. After a delay period a second visual cue provided the complementary trial information (force or grip, respectively) concerning the movement. The second cue also acted as a GO cue, instructing the monkey to initiate the grasping movement. The LFPs were recorded via a 10-by-10 Utah array (Blackrock Microsystems, Salt Lake City) which was chronically implanted between the MI and dorsal PM.

We first analyze the power spectra of the LFPs for different task periods as a function of their spatial position on the array. During the preparatory periods of the task, we find two prominent frequencies in the beta range around 23 Hz and 41 Hz, respectively. To test whether variations of these two oscillations are related to behavior, we compare their amplitude and frequency shifts of their spectral peaks between different task periods and/or trial types. Additionally, we investigate whether the spatio-temporal organization of the LFP activities exhibit wave-like properties (cf. [4]). We therefore map the coherences and corresponding phase shifts between the LFP recorded from one reference electrode and from all remaining electrodes of the array. In a next step, we pool across these maps to derive the average phase shifts as a function of distance and time for different choices of the reference electrode. Combining the estimates of the two dominant LFP frequencies with the spatial derivative of the phase maps allows us to calculate the wave velocity in a time-resolved manner. Furthermore, to examine the hypothesis that indeed the LFP exhibits a consistent wave propagation across the array, we determine the degree of coherence between each electrode and its nearest neighbors. By this analysis we can resolve the wave propagation speed and direction as a function of cortical position in the behavioral context. We finally discuss our results in the context of precise spike correlations [7] and their spatial organization in the same data set (see poster by Torre et al. and symposium 24).

Acknowledgements: This work was partly supported by the Helmholtz Alliance on Systems Biology, European Union (FP7-ICT-2009-6, BrainScaleS), Neuro_IC2010, CNRS-PEPS, Riken-CNRS Research Agreement.

References:

1. S. Katzner, I. Nauhaus, A. Benucci, V. Bonin, D. L. Ringach & M. Carandini (2009). Local origin of

field potentials in visual cortex. *Neuron*, 61(1), 35-41.

2. H. Lindén, T. Tetzlaff, T. C. Potjans, K. H. Pettersen, S. Grün, M. Diesmann & G. T. Einevoll (2011). Modeling the spatial reach of the LFP. *Neuron*, 72(5), 859-872.
3. B. E. Kilavik, A. Ponce-Alvarez, R. Trachel, J. Confais, S. Takerkart & A. Riehle (2012). Context-related frequency modulations of macaque motor cortical LFP beta oscillations. *Cereb Cortex*, 22(9), 2148-59.
4. D. Rubino, K. A. Robbins & N. G. Hatsopoulos (2006). Propagation waves mediate information transfer in the motor cortex. *Nature Neuroscience*, 9(12), 1549-1557.
5. Y. Kajikawa & C. E. Schroeder (2011). How local is the local field potential? *Neuron*, 72(5), 847-858.
6. I. Nauhaus, L. Busse, M. Carandini & D. L. Ringach (2009). Stimulus contrast modulates functional connectivity in visual cortex. *Nature Neuroscience*, 12(1), 70-76.
7. [7] M. Denker, S. Roux, H. Lindén, M. Diesmann, A. Riehle & S. Grün (2011). The local field potential reflects surplus spike synchrony. *Cerebral Cortex*, 21, 2681-2695.

Peptidergic modulation of larval *Drosophila* locomotor activity

Dennis Pauls, Kristina Jessen¹, Christian Wegener¹

¹Theodor-Boveri Institute; Biocenter, University of Würzburg, Neurobiology and Genetics, Am Hubland, 97074 Würzburg, Germany

Vertebrate and invertebrate motor control is based upon neuronal activity in local circuits in the spinal cord or ventral nerve cord, respectively [1]. Descending neurons from the brain further regulate these neuronal circuits. In insects, the central complex as the major locomotor center was shown to control different aspects of locomotor activity such as velocity, activity maintenance and orientation [2]. In addition to the central complex, the mushroom bodies are suggested to participate in locomotor control as they were shown to trigger walking behavior [3]. Neuropeptides, key players in the adaptation of neuronal networks to environmental changes, can modify and orchestrate complex behaviors and were shown to influence the modulation of locomotor behavior. In *Drosophila* different neuropeptides like adipokinetic hormone (AKH; [4]), pigment-dispersing factor (PDF; [5]) and tachykinins [6] were shown to function in different aspects of adult locomotion. However, the role of neuropeptides in larval locomotor behavior largely remains to be elucidated. In this study we focus on different neuropeptides like AKH and sNPF and their role in larval crawling behavior. First results indicate that these neuropeptides may influence the neuronal circuits underlying larval locomotor activity.

[1] Nässel, D.R. and Winther, A.M. (2010); *Prog Neurobiol.* 92, 42-104; [2] Strauss, R. (2002); *Curr. Opin. Neurobiol.* 12, 633-638; [3] Serway, C.N., Kaufman, R.R., Strauss, R., de Belle, J.S. (2009); *J. Neurogenet.* 23, 173-184; [4] Lee, G. and Park, J.H. (2004); *Genetics* 167, 311-323; [5] Mertens, I., Meeusen, T., Huybrechts, R., De Loof, A., Schoofs, L. (2002); *Biochem. Biophys. Res. Commun.* 297, 1140-1148; [6] Winther, A.M., Acebes, A., Ferrus, A. (2006); *Mol. Cell Neurosci.* 31, 399-406

No evidence for distinct gaits in *Drosophila*

Till Bockemühl, Anne Wosnitza¹, Michael Dübbert¹, Henrike Scholz¹, Ansgar Büschges¹

¹University of Cologne, Department of Animal Physiology, Zoological Institute, Zülpicher Str. 47b, 50677 Köln, Germany

Large vertebrate animals use several characteristic gaits during legged locomotion. Typical gaits in these animals comprise walk, trot, and gallop; transitions between these are speed-dependent and discontinuous. More importantly, it has been shown that specific gaits are optimal with regard to metabolic cost in a specific speed range (Hoyt and Taylor, 1981). In large quadrupeds, footfall patterns are highly reliable proxies for the gait an animal is using. It is unclear though if this approach can be generalized to all species and arbitrary numbers of legs. In insects, the notion of gaits during legged locomotion is common. Usually, however, footfall and inter-leg coordination patterns are used as the sole indicators of gaits in these animals and it has, to our knowledge, never rigorously been shown that these patterns are actually indicative of distinct gaits.

Inter-leg coordination in insects is usually classified as tripod or tetrapod. These appear as striking patterns in a footfall diagram. When used in a purely descriptive fashion, these labels are useful. There is, however, a strong tendency to refer to these coordination patterns as actual gaits, with everything that term entails. Furthermore, categorizing any observed leg coordination pattern according to these archetypical patterns might greatly de-emphasize systematic deviations from these ideal pattern or transitional forms.

Here, we argue that the common classification of insect leg movements into several gaits is unhelpful and might be misleading. We tested this claim in four different strains of *Drosophila*, two wild-type and two mutant strains, in a free-walking paradigm. The two mutant strains had reduced levels of octopamine and, consequently, walked more slowly. This allowed us to investigate a broad spectrum of walking speeds, ranging from 2 to 16 BL s⁻¹ (body lengths per second).

Our results show that *Drosophila* changes its inter-leg coordination pattern continuously over a very large speed range, rather than using several distinct coordination types. At the high end of the speed range we invariably found relatively strict tripod inter-leg coordination. However, with a decrease in speed, the strength of tripod coordination decreased as well, and at speeds below 5 BL s⁻¹ we also observed tetrapod and wave gait-like coordination. At this point the correlation between walking speed and observed coordination pattern vanished.

When we determined the duty factor (DF) for each step we found that the vast majority of steps had DFs larger than 0.5, typically associated with walking gaits. Even at very high speeds (> 15 BL s⁻¹) the DF was almost always in the range between 0.55 and 0.65. At low speeds (< 5 BL s⁻¹) it had values between 0.7 and 0.9. Steps with DFs smaller than 0.5 were very rare and mostly constituted singular events.

Finally, we found a clear relationship between speed and stepping frequency, while step amplitude and swing phase duration were mainly kept constant over the complete speed range, suggesting that *Drosophila* simply adjusts its stepping rate in order to change speed.

The findings presented here are inconsistent with the classical notion of distinct gaits as found in vertebrates. Instead, *Drosophila* seems to employ a relatively simple and unitary control strategy for inter-leg coordination over the complete range of walking speeds. Footfall patterns previously interpreted as distinct gaits might simply be special instances of a continuous spectrum.

Correction Movements and Spatial Coordination in Multipedal Locomotion

Leslie M. Theunissen, Subhashree Vikram¹, Volker Dürr^{1,2}

¹Bielefeld University, Biological Cybernetics, Universitätsstr. 25, 33615 Bielefeld, Germany

²CITEC - Cognitive Interaction Technology - Center of Excellence, Bielefeld University, Universitätsstr. 25, 33615 Bielefeld, Germany

Insects are champions of multipedal stability and coordination during adaptive locomotion in a complex environment. Here, we investigate two potential sensory mechanisms underlying multipedal stability during walking and climbing: the roles of tarsal grip for execution of correction steps and of joint angle proprioception for spatial coordination of adjacent legs. For this, we recorded unrestrained walking and climbing stick insects of the species *Carausius morosus* with a Vicon motion capture system, allowing us to reconstruct the kinematics of all body segments of interest.

- Our recent experiments on unrestrained insect locomotion reveal the presence of two distinct classes of steps: short and long steps. Owing to their anterior lift-off position and variable direction, we proposed that short steps serve to correct for insufficient grip or load during foothold. Here, we test the hypothesis if the reduction of grip will increase the likelihood of short steps, as would be expected for correction steps. For this, we manipulated the grip of a middle leg tarsus by ablating either the claw or the entire distal tarsal segment (5 animals per treatment). The results showed that the number of short steps was significantly increased in the operated leg (with reduced grip) compared to the un-operated, contralateral control leg. This is particularly evident during climbing. Our findings support the hypothesis that short steps serve to correct for insufficient grip or load during foothold.
- Appropriate spatial coordination of legs is crucial for postural stability during climbing. In stick insects, the hind and middle legs touch down close to the lift-off position of their anterior neighbour (Cruse, 1979, *Physiol.Entomol.* 4:121-124; Dean and Wendler, 1983, *J.Exp.Biol.* 103:75-94). The required transfer of spatial information between the legs involves hair fields at the proximal leg joints (Cruse et al., 1984, *J.Comp.Physiol.A* 154:695-705). Recently, we showed that this spatial coordination of adjacent legs works in all three spatial directions. Here, we test whether the trochanteral hair field, which monitors levation the trochantero-femur, affects spatial coordination in the dorso-ventral direction. After hair field ablation in a middle leg, the correlation between the positions of the operated middle and the ipsilateral hind leg was decreased, supporting our hypothesis. Furthermore, the distance between the two legs was significantly increased. Also, swing movements of the operated leg were higher and longer, and more often terminated in searching-movements than before ablation. The latter effects suggest that proprioceptive information about the coxa-trochanter joint angle is not only important for spatial coordination between legs, but also for the local control of stepping.

The results emphasize the importance of proprioceptive feedback from the tarsus and the coxa-trochanter joint in multipedal stability of insects.

The importance of charged residues in the intracellular TM3-4 loop of the inhibitory glycine receptor

Georg Langlhofer, Bea Unterer¹, Carmen Villmann¹

¹Institute for Clinical Neurobiology, AG Villmann, Versbacherstrasse 5, 97078 Wuerzburg, Germany

Glycine is the most important inhibitory neurotransmitter in the adult spinal cord and brainstem of humans and in rodents. The glycine receptor (GlyR) is a heteromeric ion channel composed of two α and three β subunits with $\alpha 1\beta$ being the most prominent receptor configuration in the ventral spinal cord.

Mutations in the *GLRA1* gene, encoding the $\alpha 1$ subunit of the GlyR, are associated with the neuromotor disorder hyperekplexia. Similar phenotypes have been found in mice with either mutations in the *Glr1* or the *Glr2* gene. These vary from point mutations to insertions, and deletions. In the mouse mutant *oscillator* a microdeletion of 7 bp result in two non-functional receptor proteins, a truncated (trc) and an elongated (elg) $\alpha 1$ variant. Previous studies showed a functional rescue of the truncated $\alpha 1$ by coexpression with an independent C-terminal folding domain. A highly positively charged motif 'RRKRR' not present in the truncated oscillator protein was identified as important determinant for cell surface integration and rescue efficiency. Since no structural information is available for the GlyR, homology modeling was used to define variable and constant regions within the intracellular TM3-4 loop. Efforts to map interaction domains between both GlyR constructs using a stepwise truncation of the TM3-4 loop from its N-terminal end identified charged subdomains being responsible for the underlying mechanism to restore functionality.

Lack of more than 49 amino acids at the N-terminus of the TM3-4 loop coexpressed with truncated $\alpha 1$ resulted in non-functionality. Moreover deletion of 55, 62, and 67 residues create positively charged N-termini, leading to the assumption that this could be a reason for the loss of interaction with the also positively charged C-terminus of truncated $\alpha 1$. Therefore converse mutations of positively charged into negatively charged residues have been generated in three truncated TM3-4 loop constructs.

Proteinbiochemical, immunocytochemical, and electrophysiological methods on transfected human embryonic kidney cells (HEK293) are used to investigate the role of charged residues for the reconstitution of GlyR function. The expression of the generated constructs was verified in whole cell lysates and membrane preparations of transfected cells. The ability of these rescue constructs to integrate into the cell surface as well as to interact with the truncated $\alpha 1$ is ongoing. Rescue experiments using whole cell patch clamp recordings will further facilitate the role of charge within the GlyR intracellular domain.

Identification of individual neurons in EMG and hook electrode recordings using spike sorting techniques

Sophie Ann Bradley, Luis A. Camunas Mesa², Ria Cooke¹, Rodrigo Quian Quiroga^{2,3},
Tom Matheson¹

¹Department of Biology, University of Leicester, University Road, LE1 7RH Leicester, United Kingdom

²Department of Engineering, University of Leicester, University Road, LE1 7RH Leicester, United Kingdom

³Institute for Neurobiology, University of Magdeburg, Germany

Electromyogram (EMG) and hook electrodes are useful tools for gathering information about neural populations. They can be less invasive than other methods and can detect activity from many neurons simultaneously. However due to the large variability in recorded signals, especially in EMGs, automatic processing of such recordings has been a major challenge.

We show that by utilising and developing aspects of the spike sorting algorithm Wave_Clus (Quian Quiroga et al., 2004, *Neural Computation*, 16(8), 1661-1687), we are able to automatically extract single-cell responses from single- and multiple-channel EMG and hook electrode recordings. We are able to validate the results by obtaining simultaneous intracellular recordings alongside the EMG or hook electrode recordings, providing a 'ground truth' for the spike sorting algorithm.

Using recordings made from the metathoracic limb of the locust *Schistocerca gregaria*, we describe the advances in spike sorting techniques that we have made and the current limitations of the approaches used.

Monitoring of reflex activity and motor function in spastic rats, nNOS, PV immunoreactivity and astrocyte's expression in spinal cord after repeated baclofen treatment

Andrea Kucharíková, Ludmila Hricová¹, Alexandra Kisucká¹, Andrea Schreiberová¹, Štefánia Gedrová¹, Nadežda Lukáčová¹

¹Slovak Academy of Sciences, Institute of neurobiology, Šoltésovej 4-6, 04001 Košice, Slovakia

Spinal cord injury interrupts important neuronal pathways between supraspinal centers and spinal cord and can lead to spasticity. Spasticity, as a velocity-dependent increase in tonic stretch reflexes can result from imbalance of inputs from reticulospinal and other descending pathways to the motor and interneuronal circuits of the spinal cord, and from absence of an intact corticospinal system. In our study we monitored the changes in reflex activity and motor function, as like as immunohistochemical changes in nNOS, PV and GFAP expression in animals subjected to spinal cord injury and baclofen treatment. The experiment was performed on 17 male Wistar rats divided into 5 groups: 1) control (n=5); 2-4) transected animals without baclofen treatment surviving for 1 (n=3), 6 (n=3) and 9 weeks (n=3); and 5) transected animals surviving for 9 weeks, repeatedly treated with baclofen (n=3). Baclofen (30mg/b.w., p.o.) was administered daily for 6 days, starting firstly 1 week and secondly 4th week after injury. The results from immunohistochemistry were visualised by fluorescent microscope. Behavioral analyses were realized by using tail-flick test and BBB-locomotor rating scale. Strong nNOS- and PV-IR was seen in a-motoneurons of lumbar spinal cord 6 and 9 weeks after transection. Repeated baclofen treatment decreased both nNOS- and PV-IR in motoneurons at 9th week of animal's survival. Hypertrophied astrocytes were detected 6 and 9 weeks post-injury. Baclofen had no effect on astrocyte's expresion. The tail-flick test values did not reveal a significant decrease of reflex activity after the treatment. BBB score values showed significant improvement of motor function in baclofen treated animals 3-6 weeks postoperatively. Our results indicate the role of NO and PV in processes related with motor functions and the improvement in locomotion of transected animals after repeated baclofen treatment.

Supported by VEGA – 2/0168/11, OPVV –ITMS 26220220127, PAV/SAV 2002-2012, CE-NOREG SAS.

Poster Topic

T22: Homeostatic and Neuroendocrine Systems, Stress Response

- T22-1A** Role of CB1 receptor and endocannabinoids on cortico-striatal connectivity of psychosocially stressed mice
Jordi Tomas Roig
- T22-2A** Hexokinase II-mediated hypoxia tolerance – a molecular switch governing cellular fate depending on the metabolic state.
Philipp Mergenthaler, David Andrews, Ulrich Dirnagl, Andreas Meisel
- T22-3A** Early-life stress induced modulation of excitatory synapses in the limbic brain
Anup Gopalakrishna Pillai, M.J. Arp, M.V. Schmidt, F. Holsboer, H. Krugers, M. Joels
- T22-1B** The neuropeptide SIFamide enhances appetitive behavior in *Drosophila melanogaster*
Simon Kobbenbring, Thomas Riemensperger, Mirjam-Vanessa Sommer, André Fiala
- T22-2B** Impact of heme and heme degradation products (HHDPs) on cerebral vascular reactivity
Alexander Joerk, Anne Wiegand, Otto W. Witte, Knut Holthoff
- T22-1C** Cortical nNOS neurons as an anatomical link to homeostatic sleep regulation
Lars Dittrich, Alan J Wilk, Michael Miller, Deepti P Warriar, Stephen R Morairty, Thomas S Kilduff
- T22-2C** Fto Controls Activity of the Dopaminergic Circuitry
Simon Hess, Martin E Hess, Linda Koch, Linda AW Verhagen, Hella S Brönneke, Marcelo O Dietrich, Sabine D Jordan, Bengt F Belgardt, Tamas L Horvath, Ulrich Rüter, Jens C Brüning, Peter Kloppenburg
- T22-3C** A Glucose Responsive Subpopulation of the Locus Coeruleus Contributes to BAT Sympathetic Traffic and Energy Homeostasis
Lars Paeger, Sulay Tovar, Simon Hess, Donald A. Morgan, Christine Könner, Hella S. Brönneke, Brigitte Hampel, P. Justus Ackermann, Nadine Evers, Hildegard Büning, F. Thomas Wunderlich, Kamal Rhamouni, Jens C. Brüning, Peter Kloppenburg
- T22-1D** Downregulation of the copper transporter dATP7 in peptidergic neurons and endocrine cells results in impaired peptide amidation
Christian Wegener, Azza Sellami, Jan A Veenstra
- T22-2D** Remote long-term registrations of sleep-wake rhythms and activity in common marmoset monkeys – homeostatic response to sleep deprivation

Kerstin Hoffmann, Alex Coolen, Christina Schlumbohm, Eberhard Fuchs

T22-3D Ultrasonic vocalizations emitted during social defeat and upon reexposure to the social defeat environment

Eberhard Fuchs, Nicole Yee, Rainer K.W. Schwarting, Markus Wöhr

Role of CB1 receptor and endocannabinoids on cortico-striatal connectivity of psychosocially stressed mice

Jordi Tomas Roig

¹CNMPB, Psychiatrie, Von-Siebold-Str. 5, D-37075 Göttingen, Germany

INTRODUCTION

The aim of the present study was to investigate the consequences of the combination of two factors: chronic psychosocial stress as environmental factor and acute treatment of CB1 antagonist and/or agonist as pharmacological factor on adult mice.

MATERIALS AND METHODS

Psychosocial stress was induced in C57Bl/6 mice using a resident-intruder paradigm (Brzózka et al. 2010). After 3 weeks daily exposure to psychosocial stress for 1 hour, mice were treated by phosphate buffer solution (Vehicle) or WIN55212.2 (3 mg/kg) with or without pre-treatment with Rimonabant (3 mg/kg). After that, mice were studied by use of behavioral tests such as Functional Observational Battery (FOB), Rota-Rod (RR), Open Field (OF) and Prepulse Inhibition test (PPI). All behavioral data were recorded at night. Finally mice were sacrificed and then prefrontal cortex and dorsal striatum areas were taken from 4 mice to estimate the concentration of anandamide (AEA), 2-arachidonoylglycerol (2-AG), N-oleoylethanolamine (OEA) and palmitoylethanolamide (PEA) in the lab of V. di Marzo. Furthermore brain coronal sections were evaluated by In Situ Hybridization (ISH) and Immunohistochemistry (ICH) against CB1 receptor.

RESULTS

Socially stressed mice showed a higher scratching activity and miccions compared to their controls ($p < 0.05$) in the Functional Observational Battery. Stress decreased the number of falls ($p < 0.01$) and increased the latency ($p < 0.05$) in Rotarod. After 2 weeks of daily psychosocial stress, mice displayed lower body weight than controls ($p < 0.01$).

WIN55212.2 strongly reduced the number of rearings ($p < 0.05$) and the climbing activity ($p < 0.05$) in the FOB. Distance travelled to the periphery, centre and total distance travelled in OF was lower in those mice treated by CB1 receptor agonist ($p < 0.001$).

Rimonabant increased the number of rearings ($p < 0.001$) and the climbing activity ($p < 0.05$) compared to WIN55212.2. In OF, rimonabant reduced the distance travelled to the periphery ($p < 0.01$) and the total distance travelled ($p < 0.05$).

In Open Field, coadministration of both drugs induced higher distance travelled in centre than Veh+Veh ($p < 0.05$) and Veh+WIN ($p < 0.001$). Rim+WIN increased the distance travelled to the periphery and the total distance travelled compared to Veh+WIN ($p < 0.001$) and Rim+Veh ($p < 0.01$).

We investigated CB1 receptor expression within specific corticostriatal circuits by mapping CB1 protein and mRNA levels. Under stress conditions, Veh+Veh and Veh+WIN mice displayed a reduction on protein expression in cortex whereas the opposite effect was observed in sensorimotor striatal sector ($p < 0.05$). Protein expression was increased in psychosocial stressed animals after acute CB1 agonist administration ($p < 0.01$). Control Rim+WIN and control Rim+Veh mice exhibited a greater number CB1 protein than those animals treated by acute CB1 agonist ($p < 0.05$). Rim+WIN reduced the number of CB1 protein in those animals exposed to 3 weeks social defeat compared to Veh+Veh group ($p < 0.05$).

We assessed the levels of AEA, 2-AG, PEA and OEA in prefrontal cortex and dorsal striatum.

2-AG levels in prefrontal cortex were lower after WIN55212.2 administration in stressed mice ($p < 0.05$). Coadministration of both drugs antagonized the effects of WIN55212.2 in control animals ($p < 0.05$). After

coadministration of Rimonabant and WIN55212.2, stressed mice displayed higher amount of 2-AG than stressed Veh+Veh ($p<0.05$), stressed Veh+WIN ($p<0.05$) and stressed Rim+Veh ($p<0.05$). In dorsal striatum, stress reduced AEA levels ($p<0.05$). After CB1 agonist administration, PEA and OEA levels were higher than Veh+Veh, Rim+WIN and Rim+Veh ($p<0.05$).

SUMMARY AND CONCLUSION

Animals exposed to acute CB1 agonist administration showed hypoactivity ({{131 McMahon 2007;}}; {{132 Rutkowska,M. 2006;}}) whereas Rimonabant abolished sedative effects of cannabinoid agonist ({{134 Jarbe,T.U. 2002;}}).

CB1 expression in cortex and striatum has an inverse relationship with low cortical and high striatal expression and vice versa, respectively ({{18 Van Waes,V. 2012;}}).

Stress stimulates the production and release of endocannabinoids mediated by HPA axis ({{135 Derks,N.M. 2012;}}; {{44 Patel 2005;}}). Our results showed a deregulation of AEA and 2-AG in those animals exposed to psychosocial stress and an increase of PEA and OEA levels after acute CB1 agonist administration.

Hexokinase II-mediated hypoxia tolerance – a molecular switch governing cellular fate depending on the metabolic state.

Philipp Mergenthaler, David Andrews², Ulrich Dirnagl¹, Andreas Meisel¹

¹Charité Universitätsmedizin Berlin, Abt. f. Experimentelle Neurologie, Charitéplatz 1, 10098 Berlin, Germany. ²Sunnybrook Research Institute, University of Toronto, Toronto, Canada.

The metabolic state of a cell is a key determinant in the decision to live and proliferate or to die. Hypoxia is a fundamental challenge of living organisms, interfering with homeostatic metabolism. It occurs physiologically during development or exercise and pathologically in vascular disease, tumorigenesis and inflammation.

We recently demonstrated that the hypoxia-inducible factor (HIF)-1-regulated glycolytic enzyme hexokinase II (HKII) functions as a molecular switch that determines cellular fate by regulating both cytoprotection and induction of cell death based on the metabolic state of the cell. We found HIF-1-dependent upregulation of HKII in primary rat brain cortical neurons upon hypoxic stimulation. We show that overexpression of HKII potently rescues both neurons from hypoxic cell death. We further demonstrate that phosphoprotein enriched in astrocytes (PEA15) is a direct molecular interactor of HKII and show that together with PEA15, HKII inhibits apoptosis after hypoxia. In contrast, HKII accelerates cell death under glucose deprivation or in the absence of PEA15. In summary, HKII both protects from apoptosis during hypoxia and functions as a sensor of glucose availability during normoxia, inducing cell death in response to glucose depletion. Thus, HKII-mediated apoptosis may represent an evolutionarily conserved altruistic mechanism to eliminate cells during metabolic starvation to the advantage of a multicellular organism.

Early-life stress induced modulation of excitatory synapses in the limbic brain

Anup Gopalakrishna Pillai, M.J. Arp², M.V. Schmidt³, F. Holsboer³, H. Krugers², M. Joels¹

¹Dept. of Neuroscience and Pharmacology, UMC Utrecht, Netherlands.

²SILS-CNS, Univ. of Amsterdam, Netherlands.

³Neurobio. of Stress, Max Planck Inst. of Psychiatry, Munich, Germany.

Stressful experiences, either early or later in life, are a potential risk factor for the precipitation of psychopathologies during adulthood. Early life stress (ELS), in particular, is known to interfere with the development of hypothalamic-pituitary-adrenal (HPA) axis; triggering a cascade of cellular and molecular changes that could potentially alter brain function. More importantly, several studies have recently reported that ELS effects on limbic brain regions makes them more susceptible to subsequent glucocorticoid exposures in adult life. We here report the effects of acute corticosterone treatment on glutamatergic synaptic currents in brain slices from adult ELS and control mice. The ELS, employed using a novel paradigm based on fragmented maternal care, was brought about by a week-long (P2-P9) rearing of mice pups in cages with limited bedding (and hence nesting) material. Whole-cell patch-clamp recording of isolated AMPA and NMDA receptor-mediated excitatory post-synaptic currents (EPSCs) were performed 2-4 hours after acute exposure to either stress levels of corticosterone (100 nM, 20 min, 30°C) or vehicle (ethanol, 114 µM). AMPA and NMDA receptor-mediated EPSCs were evoked by stimulating the Schaffer collateral inputs to CA1 pyramidal neurons. In hippocampal CA1 pyramidal neurons, we found a main effect ($p < 0.05$, two-way ANOVA) of ELS on the ratio of NMDA/AMPA EPSCs. However, we did not find any significant effect of acute corticosterone treatment, either alone (main effect) or in combination with ELS. Interestingly, ELS mice also exhibited a significant improvement in contextual fear-learning although their memory, tested one day later, was not different from control mice. Currently, we are expanding our investigations to other brain regions such as amygdala for a better understanding of the modulation of excitatory synapses induced by ELS in adult mice.

The neuropeptide SIFamide enhances appetitive behavior in *Drosophila melanogaster*

Simon Kobbenbring, Thomas Riemensperger¹, Mirjam-Vanessa Sommer¹, André Fiala¹

¹University of Goettingen, Molecular Neurobiology of Behavior, Julia-Lermontowa-Weg 3, 37077 Goettingen, Germany

Modulation of behavior according to motivational states is a fundamental feature of all animals. In this context, modulatory peptides have been intensively studied. Invertebrates possess a large variety of neuropeptides, and for many of them behavioral functions are not well understood. The neuropeptide SIFamide shows an impressively conserved sequence throughout the invertebrate evolution. Its well described immuno-reactivity in the brain of *Drosophila* suggests a neuromodulatory role in visual, tactile and signal processing. To better understand the role of SIFamide for behavior, we used the bi-partite UAS-GAL4 expression system to target the temperature sensitive cation channel dTRPA to SIFamidergic cells in order to artificially induce SIFamide release by an increase in temperature. This artificial activation of SIFamide signaling enhances locomotion of flies toward appetitive odors, whereas their response to aversive odors is unchanged. Furthermore, we show that increased SIFamide release leads to elevated food-intake, and a higher sensibility to sugar in a proboscis extension reflex paradigm. These results provide evidence that SIFamide plays a role in the mediation of food-induced and appetitive behavior.

Impact of heme and heme degradation products (HHDPs) on cerebral vascular reactivity

Alexander Joerk, Anne Wiegand¹, Otto W. Witte¹, Knut Holthoff¹

¹Hans-Berger-Klinik, Universitätsklinikum Jena, Erlanger Allee 101, 07747 Jena, Germany

Delayed cerebral vasospasm is the most common cause of mortality and morbidity in patients who survive subarachnoid hemorrhage. Despite several treatment options – primarily with the calcium channel antagonist nimodipine or hemodynamic manipulations – the neurological outcome remains unsatisfying. A substantial body of evidence has demonstrated that heme and bilirubin oxidation end products (BOXes), originating from degraded hemoglobin around ruptured blood vessels, are involved in inhibiting large conductance BK_{Ca} potassium channels in vascular smooth muscle cells, whereby blocked BK_{Ca} channels failed to hyperpolarize cell membrane and increased myogenic tone. Using DIC supported recordings of acute brain slices in mouse visual cortex we report in our in-vitro study that BK_{Ca} channel inhibitors as well as hemin caused a long-lasting decrease in arteriolar diameter in L-NAME-mediated precontracted vessels. Further investigations suggest that mixtures and even individual isomers of light-sensitive BOXes are able to induce arteriolar vasoconstriction. Based on these findings this study confirmed the expanding role of heme degradation products in impaired vascular reactivity associated with altered BK_{Ca} channel activity.

Cortical nNOS neurons as an anatomical link to homeostatic sleep regulation

Lars Dittrich, Alan J Wilk¹, Michael Miller¹, Deepti P Warriar¹, Stephen R Morairty¹,
Thomas S Kilduff¹

¹SRI International, Center for Neuroscience and Metabolic Diseases, 333 Ravenswood Avenue, 94025 Menlo Park, USA

Our lab recently demonstrated that a small population of GABAergic cortical Neurons is selectively active during sleep. These neurons can be readily identified by immunoreactivity for the enzyme neuronal nitric oxide synthase (nNOS). Based on the correlation of their activity with delta power during NREM sleep, an EEG measure for sleep intensity, we have proposed that these neurons might be involved in the homeostatic regulation of sleep. This function would require that their activation depend on sleep pressure rather than the occurrence of sleep per se. To test this hypothesis, we controlled the amount of sleep in rats by administering the hypnotics zolpidem, a GABA receptor agonist, or Almorexant, a hypocretin receptor antagonist. The drugs were administered at zeitgeber time 12, when sleep pressure is naturally lowest during the day. To increase sleep pressure in one group, rats were sleep deprived for 6 h before drug administration. Animals were then perfused and subjected to immunohistological analysis of co-expression of nNOS and the activity marker Fos. With equivalent amounts of sleep before perfusion, we found that activation of cortical nNOS neurons was controlled by sleep pressure, supporting our hypothesis. We further investigated the EEG power spectra during sleep with confirmed high or low activation of cortical nNOS neurons. We found that high activation coincided with increased NREM delta power. These results are congruent with a role for this neuronal population in the homeostatic control of sleep.

Fto Controls Activity of the Dopaminergic Circuitry

Simon Hess, Martin E Hess^{2,3,4,5}, Linda Koch³, Linda AW Verhagen³, Hella S Brönneke^{2,3,4,5}, Marcelo O Dietrich⁷, Sabine D Jordan^{2,4,5}, Bengt F Belgardt^{2,4,5}, Tamas L Horvath⁷, Ulrich Rüther⁶, Jens C Brüning^{2,3,4,5}, Peter Kloppenburg^{1,4}

¹Biocenter of the University of Cologne, Institute for Zoology, Department of Animal Physiology; ²Department of Mouse Genetics and Metabolism, Institute for Genetics, Cologne, Germany; ³ Max Planck Institute for Neurological Research, Cologne, Germany; ⁴Cologne Excellence Cluster on Cellular Stress Responses in Aging-Associated Diseases (CECAD); Center for Molecular Medicine (CMMC), Cologne, Germany; ⁵Center for Endocrinology, Diabetes and Preventive Medicine (CEDP), University Hospital of Cologne; ⁶Institute for Animal Developmental and Molecular Biology, Heinrich Heine University, Düsseldorf, Germany; ⁷Section of Comparative Medicine and Departments of Obstetrics, Gynecology & Reproductive Sciences and Neurobiology, Yale University School of Medicine, New Haven, USA

FTO is a gene associated with human obesity and energy homeostasis in mice. To this end, neither its exact function nor the pathways affected by its dysregulation are identified. We hypothesize that loss of Fto in mice has profound effects on the dopaminergic system that governs reward and locomotion-related mechanisms implicated in the etiology of obesity.

To investigate this potential role for Fto, we employed both whole body as well as a dopamine (DA) neuron specific knock out mice. Whole body inactivation leads to a loss of cocaine-induced locomotory activity and c-Fos expression in target areas of DA-neurons. Moreover, D2/D3 receptor agonist (quinpirole) treatment in the open field paradigm revealed an attenuated locomotory inhibition. On the cellular level, electrophysiological recordings demonstrate an attenuation of the effect of cocaine on AP frequency as well as quinpirole evoked silencing of DA-neurons. To further characterize the differences in D2/D3R-signaling, we performed measurements of G-protein coupled potassium channel (GIRK) currents which mediate the D2/D3R-dependent inhibition. This analysis revealed a reduction in GIRK current density compared to DA neurons of wildtype animals. Cell specific deletion of Fto leads to a similar attenuation of the cocaine and quinpirole evoked silencing of DA-neurons as well as the decrease of GIRK current density. Behavioral analysis, however, revealed baseline hyperlocomotion and a dose dependent increase in cocaine-induced locomotory activity, while quinpirole mediated locomotory inhibition is still attenuated. Moreover, DA neuron specific knock out mice exhibit a sensitivity to low cocaine concentrations in the conditioned place preference paradigm.

Thus, we demonstrate that Fto plays a critical role in dopaminergic neuron function and the dopaminergic circuitry.

A Glucose Responsive Subpopulation of the Locus Coeruleus Contributes to BAT Sympathetic Traffic and Energy Homeostasis

Lars Paeger, Sulay Tovar^{2,3,4}, Simon Hess^{1,2}, Donald A. Morgan⁸, Christine Könner^{2,3,4}, Hella S. Brönneke⁵, Brigitte Hampel^{2,3,4}, P. Justus Ackermann^{2,3,4}, Nadine Evers^{2,3,4}, Hildegard Büning⁶, F. Thomas Wunderlich^{2,3,4}, Kamal Rhamouni⁸, Jens C. Brüning^{2,3,4,7}, Peter Kloppenburg^{1,2}

¹Biocenter, Institute for Zoology, Center for Molecular Medicine (CMMC), University of Cologne, Köln, Germany

²Cologne Excellence Cluster on Cellular Stress Responses in Aging-Associated Diseases (CECAD), University of Cologne, Germany

³Department of Mouse Genetics and Metabolism, Institute for Genetics and Center for Molecular Medicine (CMMC), University of Cologne, Köln, Germany

⁴Max Planck Institute for Neurological Research, Köln, Germany

⁵Mouse Phenotyping Facility, Cologne Excellence Cluster on Cellular Stress Responses in Aging-Associated Diseases (CECAD), Köln, Germany

⁶Department I of Internal Medicine and Center for Molecular Medicine Cologne (CMMC), University of Cologne, Köln, Germany

⁷Center for Endocrinology, Diabetes and Preventive Medicine (CEDP), University Hospital Cologne, Köln, Germany

⁸Department of Internal Medicine, University of Iowa, Iowa City, USA

The Locus Coeruleus (LC) is the major source of noradrenaline (NA) in the central nervous system (CNS). Its widespread afferent and efferent projections within the CNS mark this nucleus as a key regulator in a vast number of physiological functions and impairment of the Locus Coeruleus noradrenergic system (LC-NA) has been linked to various diseases.

Besides the major roles of the LC in CNS regulation it also effects the sympathetic nervous system and has been shown to respond to a number of external and environmental stimuli. Previous studies indicate the expression of glucokinase and ATP dependent potassium channels (K_{ATP}). These molecules have been linked with glucose sensing neurons that are considered to regulate glucose homeostasis in the CNS. Here we tested if neurons in the LC are able to sense and respond to different concentrations of extracellular glucose. With perforated patch clamp recordings we found a small subpopulation of LC neurons which reduces firing frequency when extracellular glucose concentrations were decreased. This effect could be reversed via blockade of K_{ATP} channels with the specific blocker tolbutamide. LC specific expression of a mutant K_{ATP} channel variant, leading to a potassium channel which is resistant to the closure by ATP, silenced LC neurons and disrupted the ability to increase neuronal firing due to higher glucose concentrations. The expression of this mutant channels led to exaggeration of obesity in mice fed a HFD. In addition we observed structural changes of brown adipose tissue (BAT), which is considered to be a critical regulator of glucose and lipid metabolism and energy homeostasis. In this context it is of specific interest because the activity of BAT is controlled by the sympathetic nervous system and mechanisms underlying CNS dependent control of BAT SNA in response to energy availability are not well understood. Our data indicates that neurons in the LC control BAT SNA in response to different glucose concentrations.

Downregulation of the copper transporter dATP7 in peptidergic neurons and endocrine cells results in impaired peptide amidation

Christian Wegener, Azza Sellami², Jan A Veenstra²

¹Biocenter, University of Würzburg, Neurobiology and Genetics, Am Hubland, 97074 Würzburg, Germany

²Université de Bordeaux, INCIA UMR 5278 CNRS, 33405 Talence, France

C-terminal amides in neuropeptides are produced by the sequential action of two enzymes: peptidylglycine- α -hydroxylating mono-oxygenase (PHM) and peptidyl- α -hydroxyglycine lyase (PAL), which in vertebrates are combined into one bifunctional enzyme called PAM (peptidylglycine α -amidating monooxygenase), but which in *Drosophila* are encoded by different genes. PHM is one of the few enzymes depending on copper as a cofactor.

The P-type ATPase copper transporter ATP7 is a regulator of intracellular copper homeostasis. *Drosophila* has only one ATP7, while humans express ATP7A and ATP7B that are defective in Menkes and Wilson disease, respectively.

We found that *Drosophila* ATP7 is expressed by many peptidergic neurons [1]. It seemed thus likely that in the absence of ATP7, the activity of PHM might be compromised. Indeed, down-regulation of ATP7 expression by RNAi in specific peptidergic neurons led to a decrease in mature amidated neuropeptides and the appearance of C-terminally Gly-extended neuropeptides. Thus, like in mottled brindled mice [2] - a murine model for Menkes disease- neuropeptide amidation is reduced in flies. Moreover, the strength of this effect differed from one cell type to another; it was very pronounced for AKH and corazonin, but much less so for SIFamide and myosuppressin. Nevertheless, down-regulation of ATP7 specifically in the SIFamide-expressing neurons resulted in male–male courtship behavior.

The observed cell-specific degree and individual variation of neuropeptide amidation perturbation in the fly suggest that similar differences in Menkes patients could explain why symptoms vary from patient to patient.

[1] Sellami et al. 2012 FEBS Lett, in press [2] Steveson et al. 2003 Endocrinology 144: 188

Remote long-term registrations of sleep-wake rhythms and activity in common marmoset monkeys – homeostatic response to sleep deprivation

Kerstin Hoffmann, Alex Coolen², Christina Schlumbohm¹, Eberhard Fuchs¹

¹AGF, German Primate Center Göttingen, Germany

²Department of Behavioral Physiology, Center for Behavior and Neurosciences, University of Groningen, the Netherlands

The sleep-wake cycle is strongly governed by homeostatic and circadian regulation, but is nonetheless extremely vulnerable to perturbations by various internal and external factors. In fact, sleep disturbances are among the most frequently reported health problems and sleep disorders also typically occur in a variety of mental and neurological disorders. As such, appropriate animal models are required in order to better understand the regulation of sleep and the mechanisms underlying sleep disorders.

The marmoset monkey (*Callithrix jacchus*) is a small, day active, non-human primate. Experiments designed to characterize diurnal rhythms of behavioral activities and physiological functions have shown that marmosets are excellent models for basic research in chronobiology. While the basic characteristics of circadian organization are fairly well described, few studies were specifically aimed at sleep. Initial studies indicate that the sleep-wake cycle of these non-human primates resembles that of humans. Marmosets may therefore be an appropriate model to study human sleep. However, the approaches and methods used for sleep studies in marmosets so far are limited and have not yet provided a complete picture of sleep-patterns and sleep homeostasis.

As such, the objective of this study was to employ and validate the use of specific remote monitoring system technologies that enable accurate long-term measurement of sleep-wake rhythms and locomotor activity in unrestrained, pair-housed marmoset monkeys. We adapted the NeuroLogger® (NewBehavior, Zürich, Switzerland) for wireless EEG and EMG measurements and actimetry to assess full 24 h baseline patterns and the homeostatic response to sleep deprivation.

We found that marmosets showed a more or less monophasic sleep pattern with more than 85% sleep occurring during the dark phase, but also exhibited occasional daytime naps consisting primarily of NREM sleep. The animals displayed a phase-advanced sleep-wake rhythm relative to the light-dark cycle with a gradual increase in sleep starting about 2 h before the onset of the dark phase and a gradual increase in wakefulness about 30 min before the onset of the light phase. Locomotor activity was largely restricted to the light phase. Sleep deprivation (SD) was followed by a clear sleep rebound, which partly compensated for the sleep that had been lost. First, a NREM sleep rebound occurred, which was reflected by an increase in NREM sleep time and intensity. REM sleep rebound was delayed and occurred most pronouncedly in the second recovery night, but did not fully compensate for the sleep lost during SD.

In conclusion, we were able use the NeuroLogger® to make remote long-term recordings of sleep and activity in freely moving, pair-housed animals. Marmosets are day-active animals with a more or less monophasic sleep pattern and react with a clear homeostatic sleep rebound to SD. In addition to the fact that marmosets are a well-established model for neurobiological studies, the rhythms of sleep and activity in these non-human primates are more similar to humans than that of widely used species such as rats and mice. Therefore, the marmoset is an interesting species for sleep and circadian rhythm studies with broad applications and translational relevance.

K. H. was partly supported by the Institute for the Study of Affective Neuroscience (ISAN), Haifa, Israel.

Ultrasonic vocalizations emitted during social defeat and upon reexposure to the social defeat environment

Eberhard Fuchs, Nicole Yee¹, Rainer K.W. Schwarting², Markus Wöhr²

Experimental and Physiological Psychology, Philipps-University of Marburg, Marburg, Germany²

Social defeat in rats is a model of psychosocial stress with translational relevance to human social situations. Also referred to as the resident-intruder paradigm, social defeat is used as a model of acute or chronic stress and results in immediate and long-lasting behavioural and physiological effects. In this paradigm, a naive male rat (intruder) is placed in the home cage of a conspecific male (resident) that has been trained to attack intruders and defend its territory. During the attack, the intruder exhibits behavioural responses that may be considered analogous to coping strategies in humans. This includes reduced locomotion and/or freezing, submissive postures, avoidance behaviour and emission of 22-kHz ultrasonic vocalizations (USVs). The long and flat 22-kHz USVs are associated with defensive behaviour and are often referred to as “alarm calls”. However, there is experimental evidence showing that intruder rats also emit 50-kHz USVs during social defeat encounters. This is surprising since 50-kHz USVs typically occur in appetitive situations, such as during rough-and-tumble play in juveniles or mating in adults. Hence, the production of 50-kHz USVs has been linked to positive affective states. While the occurrence of 50-kHz USVs in intruder rats is difficult to explain from an emotional perspective, theories emphasizing the communicative function of USVs suggest that 50-kHz USVs serve as appeasement signals in aversive situations where the intruder also displays submission. Therefore, in this study, we tested how social defeat affects the emission of USVs. Specifically, we aimed to characterize the repertoire of USVs emitted by intruder rats during defeat and reexposure to the social defeat context the following day. The following groups of intruder rats were tested: 1) male Sprague Dawley (intruder) rats exposed to a single 10-min defeat encounter in the home cages of male Lister Hooded (resident) rats and 2) male (intruder) rats exposed to three 10-min defeat encounters in the home cages of male Lister Hooded (resident) rats on consecutive days. Two no-defeat groups served as controls: 3) male rats exposed to empty clean home cages of Lister Hooded rats and 4) male rats exposed to empty, but soiled home cages of Lister Hooded rats. Intruder rats were then re-introduced 24 hours later to the same empty home cages of resident rats for 10 min. USVs were recorded at all times by a microphone placed above the resident cage. Our results show that intruder rats emitted high numbers of 50-kHz USVs similar to control rats upon re-exposure to the social defeat environment (i.e. empty resident cage). While 50-kHz USV rates were similar in all four experimental groups tested, the time course of USV emission was markedly affected by social defeat experience. Control rats emitted most 50-kHz USVs during the first half of testing and rarely vocalized during the second half; the opposite was true for rats exposed to social defeat. Social defeat experience led to a strong reduction in 50-kHz USVs at the beginning of testing, along with an increase in latency, which indicates that the aversive test conditions inhibited 50-kHz USV emission. After a few minutes, the intruders realized no attack was imminent and the rate of 50-kHz USV increased to reach the level of controls. The present findings are in line with the notion that aversive stimuli or contexts inhibit 50-kHz USVs.

Nicole Yee is financially supported by the Kurt Lange Stiftung.

Poster Topic

T23: Neural Networks and Rhythm Generators

- T23-1A** Optogenetic dissection of adaptive inhibitory circuit motifs in adult neocortex
Dennis Kätzel, Gero Miesenböck
- T23-2A** Oscillatory entrainment of neonatal prefrontal-hippocampal networks after selective lesion of GABAergic neurons in the hippocampus
Sebastian H. Bitzenhofer, Ileana L. Hanganu-Opatz
- T23-3A** Maturation of oscillatory entrainment within prefrontal-hippocampal networks in a genetic mouse model of schizophrenia
Stephanie Riemann, Henrike Hartung, Ileana L. Hanganu-Opatz
- T23-4A** The decision to respond: the role of electrically coupled brainstem neurons in the decision to swim
Edgar Buhl, Michael Hull, Alan Roberts, Stephen R Soffe
- T23-5A** Scratch generation beyond the lumbar enlargement
Robertas Guzulaitis, Aidas Alaburda, Jorn Hounsgaard
- T23-6A** Anatomical and in vivo optical imaging analysis of metathoracic DUM neurons in the locust *Schistocerca gregaria*
Marco Schubert, Florian Bilz, Victoria Antemann, Hans-Joachim Pflüger
- T23-7A** The role of electrical synapses in a rat model of absence epilepsy: Ca²⁺ modulates the interaction between neurons of the thalamic reticular nucleus
Denise Kohmann, Kay Jüngling, Hans-Christian Pape, Philippe Coulon
- T23-8A** Cellular mechanisms of dynamical switching between different network states in the hippocampal area CA3
Shota Zarnadze, Peter Bäuerle, Tengis Gloveli, Tamar Dugladze
- T23-9A** A neuronal brake in the thalamic somato-sensory perception: the role of KCNQ channels.
Manuela Cerina, Hanna Szkudlarek, Tatyana Kanyshkova, Philippe Coulon, Sven G. Meuth, Hans-Christian Pape, Thomas Budde
- T23-10A** Instability and partial synchrony in a balanced network of resonator neurons
Maximilian Puelma Touzel, Michael Monteforte, Fred Wolf
- T23-1B** Specific signalling of propagating hippocampal sharp waves to medial entorhinal cortex layer V neurons *in vitro*

- T23-2B** Reconstruction of synaptic inputs to pre-Bötzinger complex neurons *in situ*
Anke Borgmann, Yaroslav I. Molkov, Hidehiko Koizumi, Ruli Zhang, Ilya A. Rybak, Jeffrey C. Smith
- T23-3B** Morphological and Electrophysiological Characterization of VIP Expressing Interneurons in Mouse Barrel Cortex
Alvar Prönneke, Martin Möck, Jochen Staiger
- T23-4B** Corollary discharge modulation of wind-sensitive interneurons in the singing cricket
Stefan Schöneich, Berthold Hedwig
- T23-5B** Phase-Synchrony Facilitates Binding and Segmentation of Natural Images in a Neural Network Model
Holger Finger, Peter König
- T23-6B** Circadian expression of the clock genes *period*, *timeless 1* and *cryptochrome 2* in the cockroach *Rhyparobia maderae* in different tissues and photoperiods
Achim Werckenthin, Christian Derst, Monika Stengl
- T23-7B** Towards a causal role of oscillations in visual perception
Yuranny Cabral, Melanie Wilke
- T23-8B** Function of the positive feedback circuitry within layer 4 of the barrel cortex
Omer Revah, Tatjana Tchumachenko, Fred Wolf, Michael Gutnick
- T23-9B** Modulation of hippocampal assemblies by repetitive activation of granule cells *in vitro*
Martin Keller, Andreas Draguhn, Susanne Reichinnek, Martin Both
- T23-1C** Connectivity analysis in the thoracic ganglia between local interneurons and DUM neurons
Leonard Nadler, Hans-Joachim Pflüger
- T23-2C** Functional connectivity of layer II/III GABAergic Martinotti cells in the primary somatosensory (barrel) cortex of mice
Florian Walker, Mirko Witte, Martin Möck, Jochen Staiger
- T23-3C** Fast network oscillations in the lateral septum *in vivo*
Tatiana Korotkova, Natalia P. Denisova, Alexey Ponomarenko
- T23-4C** The neuronal circuit underlying timing of eclosion behavior in *Drosophila*.
Mareike Selcho, Kouji Yasuyama, Ronja Hensgen, Christian Wegener
- T23-5C** Photoperiod affects physiological responses of circadian pacemaker neurons in the Madeira cockroach *Rhyparobia maderae*
Hongying Wei, El-Sayed Baz, Monika Stengl
- T23-6C** Impact of chronic nicotine treatment on hippocampal oscillatory activity in a G72 transgenic

mouse model for schizophrenia

Andreas Lundt, Boris Hamsch, David-Marian Otte, Karl Broich, Anna Papazoglou, Andreas Zimmer, Marco Weiergräber

- T23-7C** The Cav 2.3 R-type channel is a Modulator of Rodent Sleep Architecture
Magdalena Elisabeth Siwek, Anna Papazoglou, Marco Weiergräber, Karl Broich
- T23-8C** Task-dependent activation of thalamo-cortical networks with tACS
Christiane Weinrich, Carsten Schmidt-Samoa, Peter Dechent, Melanie Wilke, Mathias Baehr
- T23-9C** Optimized temporally deconvolved Ca²⁺ imaging reveals scale-free topology of CA1 hippocampal assemblies
Thomas Pfeiffer, Susanne Reichinnek, Andreas Draguhn, Martin Both
- T23-1D** Identification of closer-interneurons of the song pattern generator in the cricket (*Gryllus bimaculatus* DeGeer)
Joaquim Pedro Jacob, Berthold Hedwig
- T23-2D** On the impact of oscillatory synchrony on directed functional connectivity metrics: a network-model-based study
Agostina Palmigiano, Demian Battaglia, Annette Witt, Theo Geisel
- T23-3D** Applying Internal Models to Gait-Aware Neuro-Control in a Knee-Ankle-Foot-Orthosis
Jan-Matthias Braun, Poramate Manoonpong, Timo von Marcard, Markus Tüttemann, Florentin Wörgötter, Bernhard Graimann
- T23-4D** Restoration of impaired functional coupling in the amygdalo-hippocampal-cortical circuitry in NCAM deficient mice by partial NMDA receptor agonist D-cycloserine
Oleg Senkov, Gerhard Engler, Melitta Schachner, Alexander Dityatev, Andreas K. Engel
- T23-5D** Investigation into O-LM cell recruitment during hippocampal ripples in vitro
Maria Pangalos, José R. Donoso, Jochen Winterer, Aleksandar R. Zivkovic, Richard Kempter, Nikolaus Maier, Dietmar Schmitz
- T23-6D** Decoding Spatial Information from Myoelectric Signals for Control of Transradial Prostheses"
J. Michael Herrmann, David Hofmann, Dario Farina
- T23-7D** Integration and Segregation of choice relevant information across state transitions in macaque prefrontal cortex.
Stephanie Westendorff, Daniel Kaping, Martin Vinck, Stefan Everling, Thilo Womelsdorf
- T23-8D** Strain differences in iTBS rTMS effects on the cortical expression of the calcium-binding protein calbindin in rats
Annika Mix, Alia Benali, Klaus Funke
- T23-9D** Dynamics of cortical circuits with different network topologies
Rainer Engelken, Fred Wolf, Michael Monteforte
- T23-10D** Neuronal Synchronization and Aminergic Modulation of Network Oscillations – Implications for

Schizophrenia

André Fisahn, Richard Andersson, April Johnston

Optogenetic dissection of adaptive inhibitory circuit motifs in adult neocortex

Dennis Kätzel, Gero Miesenböck²

¹Institute of Neurology, University College London, Clinical and Experimental Epilepsy, Queen Square, WC1N 3BG London, United Kingdom

² Centre for Neural Circuits and Behaviour, University of Oxford, Mansfield Road, OX1 3SR Oxford, United Kingdom

The cytoarchitectonic similarities of different neocortical regions have given rise to the idea of 'canonical' connectivity between excitatory neurons of different layers within a column. Using optogenetic circuit mapping, we have recently shown, that the structure of inhibitory circuits, in contrast, differs strongly between functionally distinct neocortical areas and even within one-and-the-same area (1). Such variability in the abundance of individual motifs between regions and cells might reflect functional specializations.

Here, we examine this hypothesis by following the fate of motifs of inhibition onto layer-2/3 pyramidal neurons deriving from distinct layers in the adult mouse barrel cortex during sensory deprivation and recovery. Whisker trimming caused the selective and reversible elimination of a majority of connections from lower layers 4-5; home-layer derived inhibition, in contrast, remained stable, and layer-1 derived inhibition reversibly increased (Fig. 1).

Such changes were largely mediated by alterations in connection probability alone, while the strength of extant connections remained constant. This suggests, that connections are removed or added in an all-or-none fashion and not via stochastic elimination or addition of synapses. Solely upon recovery from deprivation, did we observe a sharp drop in connection strength from layers 1-3, which recovered only partially even after 3 month, and thus could represent a memory trace of previous experience (2). Therefore, strength and probability of connections represent independent dimensions of inhibitory circuit plasticity.

In conclusion, individual inhibitory motifs in adult neocortex are selectively altered to accommodate new function. Such motif-specificity lends credence to the proposal, that network motifs are independent modules of neural circuits, each conferring a specific function (3). Further optogenetic mapping of connections of subtypes of interneurons in the present paradigm promises to reveal therapeutic targets for the restoration of deficient inhibition, e.g. in epilepsy, by means of an increase in connection probability rather than strength.

References

- 1. Kätzel et al. The columnar and laminar organization of inhibitory connections to neocortical excitatory cells. *Nat Neurosci* (2011)
- 2. Hofer et al. Experience leaves a lasting structural trace in cortical circuits. *Nature* (2008)
- 3. Milo et al. Network Motifs: Simple Building Blocks of Complex Networks. *Science* (2002)

Fig. 1: Reversible alteration of laminar inhibitory motifs. (A) Overlay of all inhibitory input maps (n) of layer 2/3 pyramidal cells (blue triangles) from undeprived control (left), deprived (mid left), previously deprived 1-month whisker regrowth (mid right), and previously deprived 3-month whisker regrowth (right) barrel-related columns. Average strength of each input source revealed by optogenetic

mapping and measured in normalized charge flow during 100ms of the IPSC is given in gray scale. Note the loss of input sources from layer 4 and 5B in deprived condition compared to control and regrowth condition. (B) Quantification of average laminar input strength (normalized product of input numbers and average strength in each layer) given in gray scale and upper number (lower number: standard deviation). Layers in which the deprived condition (red frame) varies with statistical significance ($p < 0.05$; T-Test, Bonferroni correction) from any of the other conditions (blue frame) are indicated.

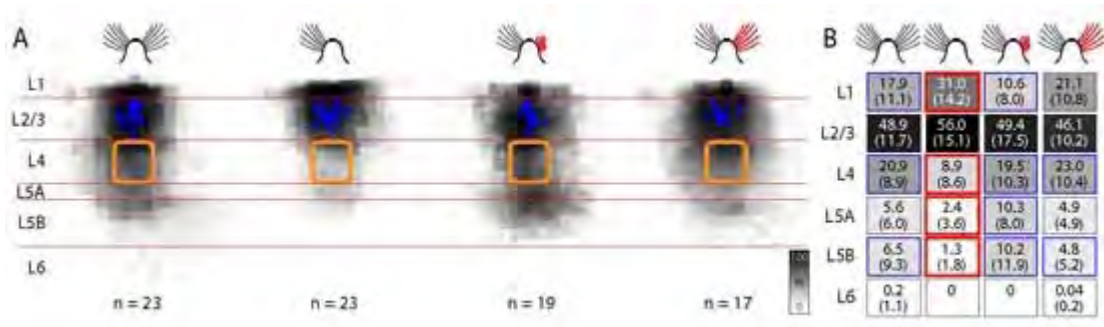

Oscillatory entrainment of neonatal prefrontal-hippocampal networks after selective lesion of GABAergic neurons in the hippocampus

Sebastian H. Bitzenhofer, Ileana L. Hanganu-Opatz¹

¹Center for Molecular Neurobiology Hamburg (ZMNH), Developmental Neurophysiology, Falkenried 94, 20251 Hamburg, Germany

The coupling of local neuronal networks in oscillatory rhythms coordinates neuronal activity in spatially distinct brain areas. This precise timing of activity is essential for the transfer and processing of information. The relevance of oscillatory coupling within neuronal networks centered on the hippocampus (HP) and prefrontal cortex (PFC) is exemplarily illustrated for mnemonic and executive processing. Simultaneous recordings from the adult HP and PFC showed that hippocampal theta oscillations control the prefrontal firing. We recently demonstrated that also during a defined period of neonatal development (first postnatal week) hippocampal theta bursts drive the discontinuous gamma-band oscillatory activity of the PFC, whereas bidirectional interactions entrain the pre-juvenile prefrontal-hippocampal network.

To dissect the cellular mechanism of the hippocampal drive to the neonatal PFC, we selectively impaired hippocampal GABAergic neurons by saporin-conjugated anti-vesicular GABA transporter antibodies (SAVAs). Small amounts (280 nl; 0.9 µg/µl) of either immunotoxin, unconjugated antibody or solvent were stereotaxically injected in the CA1 area of the intermediate/ventral HP of postnatal day (P) 0 rats. Their effects on the hippocampal morphology and electrical activity of prefrontal-hippocampal networks were investigated at P7-8.

Staining for GAD67, calbindin and parvalbumin revealed significant effects of immunotoxin but not of unconjugated antibody and solvent on the number of GABAergic neurons in the CA1 area of the HP. Simultaneous extracellular recordings of the local field potential and multiple unit activity from the neonatal PFC and HP showed that all three groups of pups express the previously described characteristic patterns of discontinuous activity: (i) spindle bursts and nested gamma spindle bursts in the PFC and (ii) sharp waves and theta oscillations in the HP. However, immunolesion of GABAergic neurons in the CA1 area significantly impaired the properties of prefrontal bursts and the synchrony within prefrontal-hippocampal networks. These data confirm the role of hippocampal drive for the generation of activity in the neonatal PFC and highlight the major contribution of GABAergic neurons for the oscillatory entrainment within prefrontal-hippocampal networks.

Supported by the DFG (SFB 936)

Maturation of oscillatory entrainment within prefrontal-hippocampal networks in a genetic mouse model of schizophrenia

Stephanie Riemann, Henrike Hartung¹, Ileana L. Hanganu-Opatz¹

¹Center for Molecular Neurobiology Hamburg (ZMNH), Developmental Neurophysiology, Falkenried 84, 20251 Hamburg, Germany

In the absence of major anatomical deficits, abnormal information processing and communication between brain regions seems to represent an important pathophysiological mechanism underlying major neuropsychiatric disorders like schizophrenia. Abnormal functional connectivity between the prefrontal cortex (PFC) and the temporal lobe, including hippocampus (HP) as well as impaired synchrony within prefrontal-hippocampal networks have been considered to account for reduced mnemonic and executive abilities of schizophrenia patients. However, the developmental profile related to the cause of disease and the underlying mechanisms of synchrony impairment within prefrontal-hippocampal networks are still unknown. We have recently shown that under physiological conditions the maturation of communication between the PFC and HP requires complex patterns of oscillatory activity and directed interactions. Here, we investigate prefrontal hippocampal interactions during neonatal development in DISC1 (Disrupted-in-Schizophrenia1) mice which contain a truncated version of the endogenous DISC1 gene ortholog designed to model the effects of the human schizophrenia-predisposing translocation.

We performed simultaneous extracellular recordings of the local field potential and multi unit activity from PFC and HP of three groups of mouse pups: (i) wild-type, (ii) heterozygote mutant, (iii) homozygote mutant. In all three groups, PFC and HP start to generate discontinuous oscillatory activity during the first postnatal week. Whereas in the PFC the main patterns of network activity are spindle bursts and nested gamma spindle bursts, the neonatal HP generates sharp-waves and theta bursts. DISC1 mutation modifies the properties of early activity within prefrontal-hippocampal networks. Moreover, we investigated the functional communication between the PFC and HP in DISC1 mice and compared it to the directed interactions previously defined in wild-type animals. These data suggest that impaired network activity during early development as a consequence of DISC1 mutation may represent an underlying mechanism of schizophrenia-related miswiring and pathophysiology in adulthood.

Supported by the DFG (SFB 936)

The decision to respond: the role of electrically coupled brainstem neurons in the decision to swim

Edgar Buhl, Michael Hull^{1,2}, Alan Roberts¹, Stephen R Soffe¹

¹University of Bristol, School of Biological Sciences, Woodland Road, BS8 1UG Bristol, United Kingdom

²University of Edinburgh, Neuroinformatics, 10 Crichton Street, EH8 9AB, Edinburgh, United Kingdom

All animals must respond to external stimuli with an appropriate reaction, e.g. to avoid predation. In mammals, higher brain centres (motor cortex, basal ganglia, thalamus) control initiation of locomotion and send commands to supraspinal locomotor centres in the brainstem. In simpler animals, however, locomotion can be initiated through direct, short pathways without higher brain centres. We ask the question, how does the hatchling *Xenopus* tadpole 'decide' to swim? In the tadpole this is possible because the electrically coupled excitatory reticulospinal neurons (dINs), which fire on every cycle and drive firing in all other 'swim' neurons, have been characterised both anatomically and physiologically [1]. Initiation of swimming following head skin stimulation requires the activation of these neurons. We have also recently identified a complete neuron-by-neuron pathway for swim initiation by head stimulation [2] and demonstrated the importance of electrical coupling in dIN recruitment [3].

We use paired whole-cell patch recordings of dINs on either side of the brain and electrically stimulate the head skin to evoke fictive swimming activity. We then build neuronal network models of the pathways exciting the dINs based on electrophysiological recordings.

The results show: (1) dINs on both sides are excited by stimulating one side of the head skin, but one side 'wins'. (2) dINs on the stimulated side receive excitation ~3 ms earlier and fire earlier. (3) Both sides receive slow building excitation which will eventually lead to firing after some 25-35 ms. (4) The ipsilateral side receives additional short latency excitation which in ~50% leads to firing. (5) Modelling shows how EPSPs in dINs summate to activate the whole population.

Here we show that a group of reticulospinal neurons (dINs), forming part of the swim CPG, make the decision of whether to swim and on which side to start. When the head skin is stimulated, dINs on both sides are excited. If the dINs on one side are recruited as a group, they initiate swimming starting on that side. We hypothesise, that the ipsilateral pathway, being shorter and stronger, initiates swimming faster but unreliably and when this pathway fails, swimming starts on the opposite side a little later. Supporting this, the ipsilateral side tends to 'win' in response to stronger stimuli.

[1] Roberts A, Li W-C, Soffe SR (2010) *Front Behav Neurosci* 4:16

[2] Buhl E, Roberts A, Soffe SR (2012) *J Physiol* 590:2453-2469

[3] Hull M, Willshaw D and Roberts A (2012) *BMC Neurosci*, 13(1):P58

Scratch generation beyond the lumbar enlargement

Robertas Guzulaitis, Aidas Alaburda¹, Jorn Hounsgaard²

¹Vilnius University, Biochemistry and Biophysics, M.K.Ciurlionio g. 21/27, LT-03101 Vilnius, Lithuania

²University of Copenhagen, Department of Neuroscience and Pharmacology, Panum Institute Blegdamsvej 3B Copenhagen, DK 2200, Denmark

Scratching is a motor response to remove an irritant from body surface (Stein, 1983). The pocket scratch reflex is one of three scratch forms generated by spinal cord of turtle (Mortin et al., 1985). Afferent input for the pocket scratch reflex enter the spinal cord close to lumbar segments (D6-D8) and the motor response recruits motoneurons in the lumbar part (D8-S2) of the spinal cord (Mortin and Stein, 1990). The key elements of the central pattern generator (CPG) of all three scratch forms reside in a few spinal segments (D7-D10) (Mortin and Stein, 1989) and was suggested be the minimal network for scratch generation. Anatomical studies have shown long propriospinal ascending connections between lumbar and thoracic spinal cord segments (Kusuma and ten Donkelaar, 1980). However, the function of these connections is not known.

In this study we recorded neurons from the mid-thoracic D4 segment during pocket scratch in the isolated carapace-spinal cord preparation from adult turtles. More than 80% of D4 neurons receive synaptic inputs during pocket scratch. About 40% of the cells were phasically active during the scratch, mostly in phase with hip flexor nerve activity. Substantial increase in synaptic noise and input conductance demonstrates that D4 neurons receive intense synaptic input during scratching. In addition we showed that the sensory input to D4 cells is modulated during rhythmic activity evoked by pocket scratch network.

In conclusion, our results show functional ascending connections between lumbar and thoracic spinal cord segments during pocket scratch. Moreover, a widely distributed CPG may serve as corollary discharge for sensory processing.

Kusuma A, ten Donkelaar HJ (1980) Propriospinal fibers interconnecting the spinal enlargements in some quadrupedal reptiles. *The Journal of comparative neurology* 193:871-891.

Mortin LI, Stein PS (1989) Spinal cord segments containing key elements of the central pattern generators for three forms of scratch reflex in the turtle. *The Journal of neuroscience : the official journal of the Society for Neuroscience* 9:2285-2296.

Mortin LI, Stein PS (1990) Cutaneous dermatomes for initiation of three forms of the scratch reflex in the spinal turtle. *The Journal of comparative neurology* 295:515-529.

Mortin LI, Keifer J, Stein PS (1985) Three forms of the scratch reflex in the spinal turtle: movement analyses. *JNeurophysiol* 53:1501-1516.

Stein PS (1983) The vertebrate scratch reflex. *SympSocExpBiol* 37:383-403.

Anatomical and in vivo optical imaging analysis of metathoracic DUM neurons in the locust ***Schistocerca gregaria***

Marco Schubert, Florian Bilz¹, Victoria Antemann¹, Hans-Joachim Pflüger¹

¹Freie Universität Berlin, Institut für Biologie - Neurobiologie, Königin-Luise-Str. 28/30, 14195 Berlin, Germany

The biogenic amine octopamine is a neuromodulatory transmitter in insects that plays an important role in a variety of behavioral contexts. In this study we address the functional role of octopaminergic neurons (ONs) in the locust motor system by applying optical imaging techniques. A well described network of motor neurons reliably generates rhythmic locomotory patterns and a parallel small-sized network of ONs connects to this motor network. Amongst the latter, octopaminergic unpaired median neurons, with either dorsal or ventral cell bodies (DUM or VUM neurons, respectively) are clustered along the midline of the thoracic and abdominal ganglia. Both networks receive 'top-down' input from central areas of the suboesophageal ganglion and the brain, and are activated in parallel with high synchrony. It has been suggesting that the ON network modulates synaptic efficacy of neuromuscular synapses and of excitatory synapses onto inter- and motor neurons, providing a gating and/or gain control mechanism. The focus of our investigation was centered on the functional integration of DUM neurons in the motorneuron network of the locust, *Schistocerca gregaria*, using calcium sensors for optophysiological measurements in the DUM soma cluster of the metathoracic ganglion. The metathoracic ganglion houses at least 19 DUM neuron cell bodies located dorsal in a single layer. We were able to stain and identify up to 19 cell bodies of DUM neurons for anatomical identification using different staining techniques (bath application, backfilling and electroporation) with several calcium sensitive fluorescent dyes (Calcium Green 2 AM, Fura-2 dextran, Calcium Green-1 dextran and Oregon Green BABTA-1 dextran) and neurobiotin. So far, functional calcium imaging signals after physical stimulation of the animals' antennae or hind legs could only be found after backfilling (via nerve N3, 4 & 5) with the Ca²⁺ sensor Calcium Green-1 dextran (3000 MW) staining up to 5 cell bodies in an individual animal. Since we were able to image only a subset of DUM neurons we are not yet capable of studying simultaneously the octopaminergic influence of the whole population on the animals' behavior, which is the goal of this study. In particular we want to compare the default pattern of the system under reduced sensory input with activation patterns during induced flight and walking behavior. Such data would allow insight in the connectivity within the ensemble of DUM neurons and their connectivity to other parts of the neuronal network and their functional involvement in switching and modulating behavioral states. We feel assured that further development of the staining technique and preparation of the animals will lead to a successful investigation of the whole set of DUM neuron cell bodies and will allow the analysis of their functional characteristics.

The role of electrical synapses in a rat model of absence epilepsy: Ca^{2+} modulates the interaction between neurons of the thalamic reticular nucleus

Denise Kohmann, Kay Jüngling¹, Hans-Christian Pape¹, Philippe Coulon¹

¹Westfälische Wilhelms-Universität Münster, Institut für Physiologie I, Robert-Koch-Str. 27a, 48149 Münster, Germany

In the thalamic reticular nucleus (TRN), neurons are coupled to each other by electrical synapses. These are believed to play a major role in regulating synchronous activity in the brain during sleep and epileptic seizures. This study aims to investigate the role of these electrical synapses in childhood absence epilepsy, an idiopathic, generalized, and non-convulsive form of epilepsy that is characterized by 2.5-4 Hz spike-and-wave discharges (SWD) in the EEG. We compared the properties of electrical synapses in Genetic Absence Epilepsy Rats from Strasbourg (GAERS) to those of Non Epileptic Control Rats (NEC) in order to determine the contribution of electrical coupling to pathophysiological rhythmogenesis. Paired recordings using the whole-cell patch-clamp technique were performed in TRN neurons in acute brain slices from GAERS and NEC rats between age p12 and p15. Ca^{2+} -imaging was done using two-photon laser-scanning-microscopy.

The probability of electrical coupling between GAERS and NEC was not significantly different and, in both strains, the coupling was blocked in the presence of carbenoxolone, a connexon blocker. The coupling coefficient decreased in the pre-synaptic cell in the course of eliciting 50 rebound bursts with 2 Hz. This could be due to the observed Ca^{2+} -influx into the pre-synaptic cell or due to a pH increase, which is known to inhibit electrical coupling in neurons. Further experiments will be performed to test these hypotheses.

Cellular mechanisms of dynamical switching between different network states in the hippocampal area CA3

Shota Zarnadze, Peter Bäuerle², Tengis Gloveli³, Tamar Dugladze⁴

¹Charité Universitätsmedizin Berlin, Institut für Neurophysiologie (CCO), Chariteplatz 1 (Virchowweg 6), 10117 Berlin, Germany

²Charité Universitätsmedizin Berlin, Institut für Neurophysiologie (CCO), Chariteplatz 1 (Virchowweg 6), 10117 Berlin, Germany

³Charité Universitätsmedizin Berlin, Institut für Neurophysiologie (CCO), Chariteplatz 1 (Virchowweg 6), 10117 Berlin, Germany

⁴Charité Universitätsmedizin Berlin, Institut für Neurophysiologie (CCO), Chariteplatz 1 (Virchowweg 6), 10117 Berlin, Germany

Hippocampal network shows three types of oscillatory activity in vivo in a behavioral-dependent manner: theta (5-10 Hz) and gamma (30-100 Hz) rhythms and sharp wave-associated field ripples (SWR, 100-300 Hz). However, underlying cellular mechanisms of transition from one oscillatory state into another is still ill-defined. We aimed to clarify the properties of certain cell types of the hippocampus which enable the network to create a functional neuronal circuit capable of switching between different oscillatory states. We recorded from perisomatic-targeting fast spiking basket cells and pyramidal cells in area CA3 during spontaneously occurring SWRs and pharmacologically (kainic acid, KA, 400 nM) induced gamma frequency oscillations. The cells were recorded in cell-attached configuration and the discharge pattern and their phase relationship to simultaneously recorded local field potential was studied. The excitatory and inhibitory postsynaptic currents were analysed in whole-cell configuration. Our results show that most of the pyramidal cells are silent during SWRs and discharge with a low frequency (<5 Hz) during gamma oscillations. In marked contrast, all recorded fast spiking basket cells fire with one or several spikes per SWR-episode and discharge on every gamma cycle strongly phase-locked to the field oscillations. We conclude that the firing pattern of these inhibiting interneurons may determine the network states in hippocampal area CA3.

A neuronal brake in the thalamic somato-sensory perception: the role of KCNQ channels.

Manuela Cerina, Hanna Szkudlarek¹, Tatyana Kanyshkova¹, Philippe Coulon^{1,2}, Sven G. Meuth^{2,3}, Hans-Christian Pape^{1,2}, Thomas Budde^{1,2}

¹Institute of Physiology I, Westfälische Wilhelms-Universität Münster, Germany;

²Otto Creutzfeldt Center for Cognitive and Behavioral Neuroscience, Westfälische Wilhelms-Universität Münster, Germany;

³Institute of Neuropathophysiology, Westfälische Wilhelms-Universität Münster, Germany;

KCNQ channels are the molecular substrate of the slow voltage-activated delayed rectifier type K⁺ current termed I_M. This current operates below action potential threshold thereby regulating neuronal firing and excitability. Recently we detected the mRNA and protein expression of KCNQ2 and KCNQ3 in the somatosensory ventrobasal thalamic complex (VB). To determine the contribution of KCNQ channels to thalamic activity modes and to analyse their possible role in somatosensory and noxious stimulus processing, VB neurons were recorded in vitro.

Whole-cell patch-clamp recordings were performed in thalamocortical relay (TC) neurons in brain slices. Moreover, hot plate experiments were performed in freely behaving mice during acute pain stimulation.

TC neurons generated a slow K⁺ outward current component which was enhanced and inhibited by specific KCNQ channel openers (retigabine) and inhibitors (XE991), respectively. Furthermore this current component was inhibited by muscarinic agonists (OxoM) and enhanced by specific anti-inflammatory compounds such as diclofenac and meclofenamate. In current-clamp recordings retigabine reduced burst and tonic firing of TC neurons. During hot plate testing intrathalamic injection of retigabine and XE991 significantly increased and decreased the latency to the occurrence of aversive behaviour, respectively. Furthermore the anti-nociceptive effect of retigabine was completely reverted by co-injection of XE991.

These findings indicate that VB TC neurons generate I_M which modulates cellular excitability by inducing spike frequency adaptation and may play an important role in limiting neuronal responses to acute pain stimuli. Our study introduces thalamic KCNQ channels as possible targets for a number of antinociceptive compounds.

Instability and partial synchrony in a balanced network of resonator neurons

Maximilian Puelma Touzel, Michael Monteforte^{1,2}, Fred Wolf^{1,2}

¹Department of Nonlinear Dynamics, Max Planck Institute for Dynamics and Self Organization, Am Faßberg 17, D-37077 Göttingen, Germany

²Bernstein Center for Computational Neuroscience, Goettingen

The balanced state, first proposed in cortical network models of integrator (type I) neurons, is a robust, collective network state that keeps the mean excitatory and inhibitory input to each cell equal, leaving the fluctuations to drive spiking [1]. For leaky-integrate-and-fire networks with excitatory external drive balanced by purely inhibitory and unstructured recurrent connectivity, a critical perturbation size was found beyond which the networks are dynamically unstable [2,3]. This critical size should determine the capacity of the 'coding with trajectories' function of the network, and tuning it may be useful for downstream learning [4]. A candidate network for this kind of network function is the olfactory bulb. Since the principal cells there display a variety of resonator (type II) properties[5], in this work we extend the research of the balanced state to cover both modes of single neuron dynamics using a 2D linear threshold neuron in a spiking network model roughly analogous to the olfactory bulb in zebrafish.

Using the analytic solution to this 2D model neuron, we implemented an efficient and precise root finding algorithm to obtain the next spike time within a network. With this, we performed numerically exact, event-based network simulations, iterating from one spike in the network to the next. By varying a single parameter, we explore the network dynamics across the transition from integrator to resonator units, ending with a network that replicates the zebrafish bulb's first and second order spiking statistics and its network oscillation. To study the effects of the intrinsic resonance on the network oscillation, we analytically derived the firing rate response of the single neuron to weak oscillatory synaptic input[6] and show a resonance that depends on the intrinsic frequency. Then, to assess the stability of such networks, we analytically calculated the single spike Jacobian of the event map, which describes how small perturbations evolve between spikes and which we use to compute the full Lyapunov spectrum as in [7]. Along with an analysis of stability with respect to larger size perturbations, we conclude that the characteristic boundary in type I networks persists across the transition to those of type II and is thus relevant for further study in the context of sensory processing in the olfactory bulb.

1. Van Vreeswijk C., Sompolinsky H. Science (1996)
2. Zillmer, R. , Brunel, N., Hansel, D. PRE (2009)
3. Monteforte, M., Wolf, F. PRX (in press, arxiv 1102.5428)
4. Niessing, J., Friedrich, R. Nature (2010)
5. Desmaisons, D. , Vincent, J.D., Lledo, P.M. J. Neuro., (1999)
6. Tchumachenko, T., Wolf, F. PLOS Comp. Biol. (2011)
7. Monteforte, M., Wolf, F. PRL (2010)

Specific signalling of propagating hippocampal sharp waves to medial entorhinal cortex layer V neurons *in vitro*

Fabian C. Roth, Katinka Marie Beyer¹, Martin Both¹, Andreas Draguhn¹, Alexei V. Egorov¹

¹Institute of Physiology and Pathophysiology, Department of Neurophysiology, University of Heidelberg; Bernstein Center for Computational Neuroscience (BCCN) Heidelberg/Mannheim, Heidelberg, Germany

Sharp wave-ripple complexes (SPW-Rs) are coordinated network events that emerge in the CA3 subregion of the hippocampus and propagate via the "output loop" into the entorhinal cortex (EC). These patterns of activity appear to contribute to memory consolidation, most likely by inducing lasting memory traces in the neocortex. As a consequence, propagating SPW-Rs should induce specific signals in downstream cortical areas.

We therefore analyzed the reaction of layer V (LV) principal neurons of the medial EC (mEC) to afferent SPW-Rs in horizontal brain slices of mice. Extracellular recordings revealed that positive-going sharp waves in the pyramidal cell layer of CA1 were regularly followed by negative field potential deflections in deep entorhinal layers (5-10 ms delay; ~65 μ V amplitude). Superimposed oscillations ("ripples") were slower in the EC than in CA1. Intracellular recordings revealed SPW-R-associated depolarizations in mEC LV neurons, which remained subthreshold in our slice preparation. Amplitude of SPW-R-associated postsynaptic potentials (PSPs) was positively correlated with the amplitude of preceding SPW-Rs in CA1. Conversely, delay time of cellular response in mEC was negatively correlated with amplitude of field events in CA1. Synaptic potentials had complex waveforms, often showing superimposed rhythmic activity with leading frequencies below the dominant ripple frequency observed in CA1. Conductance analysis indicated that network-associated synaptic input was mostly excitatory. This was confirmed in whole-cell voltage clamp recordings by isolating GABAergic currents at 0 mV holding potential and glutamatergic currents at the GABA reversal potential (~-74 mV). There were almost no GABAergic components observed at 0 mV holding potential but strong inward currents at -74 mV or at -90 mV.

In order to investigate the input-specificity of the postsynaptic signals in mEC LV neurons, we analyzed their correlation with different waveforms of field-SPW-Rs in CA1. Field potentials were sorted into self-organizing maps, and the distribution of cellular events amongst prototypic waveforms was quantified. We found significant values for sparsity and information in comparison to shuffled data, indicating transfer of specific information between both regions. This specificity was almost entirely carried by synaptic excitation, in contrast to CA1 pyramidal cells where GABAergic PSPs contributed significantly to sparsity and information. In summary, our data reveal a precise transfer of information between the hippocampus and the medial entorhinal cortex, indicating that SPW-Rs may support specific memory transfer from hippocampal assemblies to upstream networks in the mEC.

Supported by BMBF (01GQ1003A, BCCN Heidelberg/Mannheim, B3) and by IB BMBF (RUS 11/015).

Reconstruction of synaptic inputs to pre-Bötzinger complex neurons *in situ*

Anke Borgmann, Yaroslav I. Molkov², Hidehiko Koizumi¹, Ruli Zhang¹, Ilya A. Rybak⁴,
Jeffrey C. Smith¹

¹National Institutes of Health, Cellular and Systems Neurobiology Section, NINDS, Bethesda, MD, USA

²Dept. of Mathematical Sciences, Indiana University - Purdue University Indianapolis, IN, USA

³Institute of Zoology, University of Cologne, Cologne, Germany

⁴Dept. of Neurobiology and Anatomy, Drexel Univ. Col. of Med., Philadelphia, PA, USA

The pre-Bötzinger complex (pre-BötC) is an essential component of the brainstem respiratory rhythm-generating circuitry and receives convergent synaptic inputs from numerous neuron populations. Phasic excitatory and inhibitory synaptic inputs during the respiratory cycle are thought to dynamically shape membrane potential trajectories and spiking patterns of pre-BötC neurons. Therefore, synaptic inputs reflect the functionally interacting neuron populations involved in rhythm and inspiratory-expiratory pattern generation. The dynamic patterns of these synaptic inputs to respiratory neurons of the pre-BötC have not been systematically studied and characterized experimentally. Accurate temporal reconstruction of these synaptic input patterns is particularly important for unraveling functional connections between populations of respiratory neurons and for testing current models of the respiratory central pattern generator that incorporate specific excitatory and inhibitory circuit mechanisms for rhythm and pattern generation.

We applied sharp microelectrode intracellular recording techniques to characterize spiking patterns, membrane potential trajectories, and synaptic conductances of pre-BötC respiratory neurons within *in situ* perfused brainstem-spinal cord preparations of mature rats. These preparations generate a three-phase respiratory pattern and provide mechanically stable conditions for intracellular recordings in functionally intact brainstem circuits. We developed analytical techniques that allow reconstruction of the patterns of synaptic conductances at high temporal resolution from intracellular recordings of membrane potential trajectories.

We recorded different types of inspiratory and expiratory pre-BötC neurons, analyzed the dynamical changes of excitatory (Ge) and inhibitory (Gi) conductances and reconstructed their synaptic input patterns. The different types of respiratory neurons showed characteristic patterns of Ge/Gi fluctuations throughout the respiratory cycle. Inspiratory neurons exhibited strong excitatory inputs (large dynamic increases in Ge) during their spiking phase followed by a wave(s) of inhibitory inputs during the expiratory period with large increases in Gi and temporal patterns consistent with two populations of inhibitory neurons providing inputs that coordinate inspiratory to expiratory and expiratory to inspiratory phase transitions. Expiratory neurons exhibited strong inhibition during the inspiratory phase, consistent with the rhythmic alternation of inspiration and expiration, and changes in Ge indicating reciprocal interactions between two major populations of inhibitory neurons coordinating the generation of two (E1 and E2) phases of expiration. The network architecture suggested by these synaptic input patterns is generally consistent with circuit architectures proposed in previous models to account for a 3-phase rhythmic respiratory pattern (Smith et al. 2007).

Smith JC, Abdala AP, Koizumi H, Rybak IA, Paton JF: Spatial and functional architecture of the mammalian brain stem respiratory network: a hierarchy of three oscillatory mechanisms. *J Neurophysiol* 2007, 98:3370-3387.

Morphological and Electrophysiological Characterization of VIP Expressing Interneurons in Mouse Barrel Cortex

Alvar Prönneke, Martin Möck¹, Jochen Staiger¹

¹Georg-August-Universität Göttingen, Neuroanatomie, Kreuzberggring 36, 37075 Göttingen, Germany

GABAergic inhibitory interneurons play an important role in information processing in the barrel field of the somatosensory cortex. There are different subgroups of inhibitory interneurons, generally distinguished by morphology, electrophysiology and molecular markers. One of the least well characterized groups expresses vasoactive intestinal polypeptide (VIP) and can be found throughout all six layers of the neocortex. Therefore we performed a morphological and electrophysiological characterization of VIP expressing interneurons in transgenic 24 – 36 days old VIPcre dTomato labeled mouse brain slices by whole cell patch clamp recordings, staining with biocytin and subsequent quantitative reconstructions of somatodendritic and axonal morphologies. All of these varying properties were obtained in a quantitative manner, statistically analyzed and compared to possibly distinguish between different subtypes of VIP expressing interneurons. Somatodendritic morphologies were diverse, including bipolar, modified bipolar (i.e. tripolar) and tufted configurations. Dendritic trees from a vast majority of neurons showed many varicosities and spanned across at least one neighboring layer, mostly staying within the home column but sometimes also reaching adjacent columns. Axonal arborizations formed by layer II/III VIP cells were usually found in layer II/III and descended further towards layer VI with a varying number of boutons in supra- and infragranular layers. Most VIP neurons in infragranular layers had axonal projections more locally and were in general never ascending. Some VIP neurons also extended their axons into the white matter. Membrane properties and firing patterns of VIP neurons varied greatly throughout layers. The most abundant firing pattern observed was regular spiking (also called adapting) with different adaption ratios in response to higher current pulses. A minority of cells across all layers showed irregular spiking patterns, but bursting cells only seemed to be present in layer II/III. Although the enormous variability in the before mentioned parameters does not suggest a classification scheme yet, we found one distinct subpopulation of layer II/III VIP neurons which can be identified by a specific firing behavior: A switch from a tonic to a bursting firing mode contingent on the membrane potential. This behavior is reminiscent of thalamic relay cells, which show a state dependent switch from tonic to burst mode and has not been shown in VIP expressing interneurons as of yet. Thus these specific layer II/III VIP neurons show a brain state dependency that, by virtue of the extensive translaminal axonal arbor, will have a profound effect on columnar sensory processing.

Corollary discharge modulation of wind-sensitive interneurons in the singing cricket

Stefan Schöneich, Berthold Hedwig¹

¹University of Cambridge, Department of Zoology, Downing Street, CB2 3EJ Cambridge, United Kingdom

Distinguishing environmental (exafferent) from self-generated (reafferent) sensory inputs that occur simultaneously in the same pathway is a fundamental challenge for the nervous system in every actively behaving animal. Crickets are equipped with a highly wind-sensitive cercal pathway that triggers fast escape reactions via ascending giant interneurons when detecting the airflow of an approaching predator. In a singing cricket, however, the air currents generated by the rhythmic wing-movements underlying sound production similarly stimulate the cercal system. But how can male crickets sing continuously for hours without getting startled by the self-generated cercal wind-stimulation and at the same time maintain high sensitivity of the cercal predator avoidance pathway to external stimulation? To answer this question we intracellularly recorded wind-sensing cercal afferents and ascending giant interneurons in the terminal ganglion of fictively singing crickets. Singing behaviour was elicited by microinjection of Eserine into the brain and after severing all mesothoracic wing nerves the fictive singing motor pattern was monitored by extracellular motoneuron recording. Intracellular recordings from the terminal branches of wind-sensitive afferents revealed that, in contrast to the auditory pathway, there are no primary afferent depolarizations in phase with the singing rhythm that would indicate a presynaptic inhibition at the first synapse of the wind-sensitive pathway. Recordings from the dendrites of the wind-sensitive ventral giant interneurons (GI8-1a and GI8-1b), however, revealed rhythmic postsynaptic inhibition occurring strictly in phase with the syllable rhythm of the singing pattern. In fictively singing crickets, where no self-generated wind occurs, the corollary discharge inhibition in the giant interneurons was sufficient to suppress spike responses towards external wind stimulation whenever the stimulation coincided with the singing motor activity. The inhibition is precisely timed to suppress responses to self-generated air currents whereas the interneurons remain sensitive to external wind-stimulation in the chirp intervals. During singing this mechanism prevents inadvertent escape responses due to self-generated airflow by precisely timed corollary discharge inhibition of wind-sensitive giant interneurons while maintaining responsiveness of the cercal escape pathway in the singing intervals. (This study was supported by the BBSRC and The Isaac Newton Trust)

Phase-Synchrony Facilitates Binding and Segmentation of Natural Images in a Neural Network Model

Holger Finger, Peter König^{1,2}

¹Institute of Cognitive Science, University of Osnabrück;

²Institute of Systems Neuroscience, University Medical Center Hamburg Eppendorf

Synchronization has been suggested as a mechanism of binding distributed feature representations facilitating segmentation of visual stimuli. Here we apply and investigate the validity of this concept on natural visual stimuli. We extend rate-based models with a second network variable representing the relative phase of oscillating activity of different neurons. Natural stimuli allow comparisons of segmentations based on the synchronization pattern with human experts.

Convolutional filters based on retinal and LGN processing mechanisms are applied to images followed by a sparsifying local mean subtraction and half-wave rectification. This results in the neuronal activity levels of different feature maps akin to primary visual cortex. The synchronizing and desynchronizing intralayer connection strengths in the network are set according to the second order statistics of network activation induced by natural images (Fig A). These intralayer connections are sparse to reduce the high demand on computational resources. The mathematical framework for the phase update rule is biologically motivated and based on coupled neural oscillators close to their limit cycle. The binding of a set of neurons is represented by the similarity of the phase variables, which biologically corresponds to synchronized activity. The segmentation by synchrony is evaluated using masks from a hand labeled image dataset (LabelMe). We compare the phase segmentation to a baseline using the same segmentation mask on nonmatching images (Fig B).

Our simulation results show a continuously increasing phase synchrony between neurons within segmentation masks. A peak in segmentation performance is achieved after around 20 network iterations with a 32% increase in the mean synchrony in the matching condition compared to the nonmatching condition. We further evaluate the synchrony within segments relative to the synchrony over segment boundaries to account for different levels of network synchronization. The phase segmentation outperforms a segmentation based on chromatic hue for small to medium segment sizes with a performance improvement of 83% for segment sizes up to 1000 pixels (Fig C). The results indicate that the hue segmentation is superior for larger segment sizes because the phase interaction is weak over larger distances in visual space involving long chains of neurons with many synapses. Different sparse connectivity patterns were investigated and a better segmentation performance was achieved with a probabilistic connectivity matrix compared to a symmetric connectivity matrix.

We show that the phase variables in the proposed activity based network facilitate binding of populations of active neurons that are encoding different attributes of the same stimulus. This approach allows combining multi-scale image segmentation and object recognition into a hierarchical neuronal network model. This has the advantage that binding and extraction of features can be accomplished simultaneously at different scales of the hierarchy. Furthermore, top-down feedback can modulate feature binding while intralayer feature binding can modulate bottom-up feature extraction processes.

B) Evaluation Method

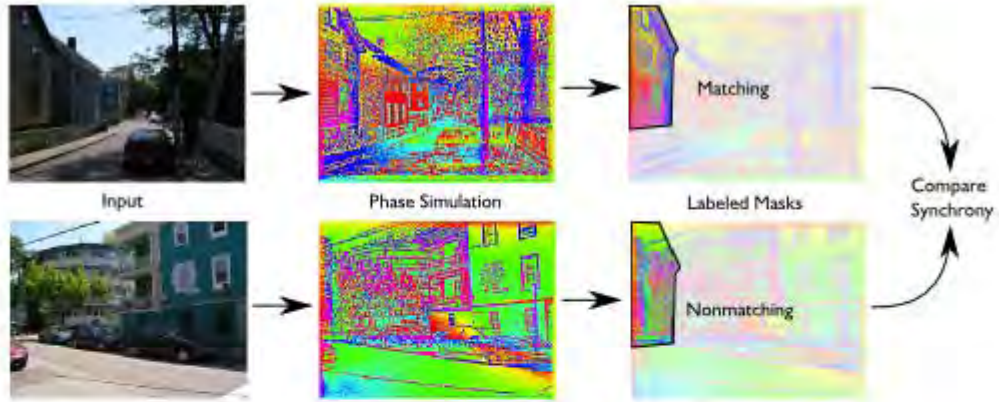

A) Network Connectivity

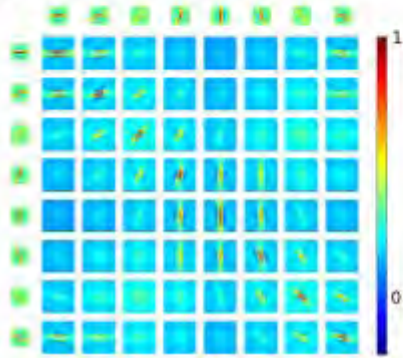

C) Segmentation Results

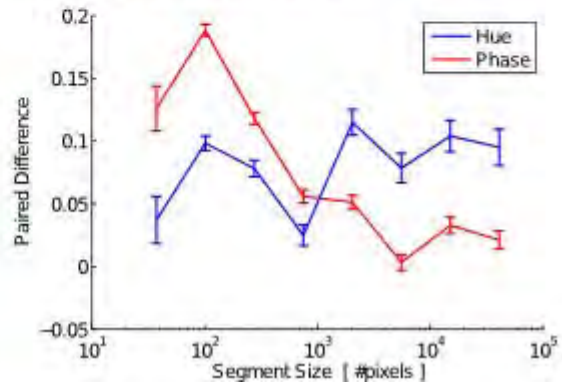

Circadian expression of the clock genes *period*, *timeless 1* and *cryptochrome 2* in the cockroach *Rhyparobia maderae* in different tissues and photoperiods

Achim Werckenthin, Christian Derst², Monika Stengl¹

¹University of Kassel, FB 10, Biology, Animal Physiology, Heinrich-Plett-Str. 40, 34132 Kassel, Germany

²Institute for Integrative Neuroanatomy, Charité University Medicine Berlin, 10115 Berlin, Germany

Circadian clock genes have been studied in various insects. While the basic principle is similar in all species examined so far, in detail there are striking differences. The molecular clockwork is best characterized in *Drosophila melanogaster*, with interlocked feedback loops leading to 24 hour rhythms in mRNA and protein concentrations. *Period* (*per*) and *timeless 1* (*tim1*) are part of the so called "core feedback loop". Their proteins inhibit their own expression by interaction with the CLOCK/CYCLE heterodimer, which positively regulates *per* and *tim1* expression. *Cryptochrome 2* (*cry2*) is absent from the genome of *D. melanogaster*, but is known from vertebrates and other insects like *Apis mellifera*, *Danaus plexippus* and *Acyrtosiphon pisum*. In these animals, it is probably mainly a part of the negative limb of the *per/tim* feedback loop.

The majority of insects examined for circadian genes so far are holometabolous insects like *D. melanogaster*, *A. mellifera*, *Tribolium castaneum*, several Lepidopteran (*Antheraea pernyi*, *Bombyx mori*, *Danaus plexippus*) and Dipteran species (*Drosophila* spp., *Protophormia terraenovae*, *Anopheles gambiae* and others). Less attention has been directed to hemimetabolous insects. Circadian genes of *A. pisum*, *Pyrrhocornis apterus*, *Riptortus pedestris* and *Gryllus bimaculatus* were characterized. In cockroaches, partial sequences of *Periplaneta americana* *per* and *tim1* and *per* sequences of *Blattella germanica* and *Blattella bisignata* have been published.

The Madeira cockroach *Rhyparobia maderae* is a model organism for behavioral and neuropeptidergic circadian research since the 1960's, but hardly anything is known about the molecular basis of the circadian clock in this insect. We cloned and analyzed *R. maderae* *per*, *cry2*, and a partial sequence of *tim1*, and examined the circadian expression profile of these genes. Sampling every 4 hours, we subsequently used quantitative PCR to determine mRNA levels of neuronal (brain and excised accessory medulla) and non neuronal tissue (Malpighian tubules). In neuronal tissue, expression levels of *rmPer*, *rmTim1*, and *rmCry2* oscillated in a circadian manner. Highest values occurred in the first half of the night, and oscillations mostly continued in constant conditions. In contrast to *D. melanogaster*, but similar to *Gryllus bimaculatus* we did not find any significant oscillations in Malpighian tubules.

In another approach, we examined the photoperiod dependent plasticity of clock gene expression. In addition to the light regime employed in previous experiments (LD 12:12), we used animals raised in short- (LD 6:18) and long-day (LD 18:6) conditions. The peak levels of *rmPer*, *rmTim1*, and *rmCry2* expression adjusted relatively to the beginning of the scotophase, and the daily mean of expression levels was significantly higher in long-day versus short-day animals. This shows that the phase and the amplitude is light-dependently regulated. To summarize, *rmPer*, *rmTim1*, and *rmCry2* are most probably part of the Madeira cockroach nuclear circadian clock which has the ability to adjust to different photoperiods.

[Supported by DFG grant STE531/15-2 and 18-1 to Monika Stengl]

Towards a causal role of oscillations in visual perception

Yuranny Cabral, Melanie Wilke¹

¹UMG, Cognitive Neurology, Robert-Koch-Str., 40, 37075 Göttingen, Germany

Synchronized beta (15–30 Hz) and gamma (>30 Hz) band oscillations in the visual cortex might constitute the neural substrate of visual perception. In these frequency ranges, field potential activity has been correlated with the actual percept as opposed to the retinal input in a multitude of bistable perception paradigms (Summerfield et al., 2002; Wilke et al., 2006; Piantoni et al., 2010). Here we used 'transcranial alternating current stimulation' (tACS), thought to entrain endogenous neuronal oscillations in a given frequency range, to test the causal role of oscillatory activity in visual perception. tACS was applied over the visual cortex of 22 healthy subjects while they reported their percepts in the context of two bistable perception paradigms: (i) "Generalized Flash Suppression" (GFS), where a salient stimulus disappears from awareness after the appearance of a surround of moving (Wilke et al., 2003) dots; and (ii) "Structure from Motion" (SfM), where a sphere is perceived to rotate in the left- or rightward direction (Wallach and O'Connell, 1953; Sperling and Doshier, 1994). We used four different tACS stimulation frequencies (10 Hz (alpha), 16 Hz (beta), 60 Hz and 80 Hz (gamma) and sham stimulation as a control. Every subject participated in 3-6 sessions in which two different stimulation conditions were tested in a pseudorandomized order. We found that stimulation in the gamma frequency range influenced the percepts in the two bistable paradigms, but stimulation in the beta frequency range did not. Specifically, in the GFS paradigm, tACS in the higher gamma range (60, 80 Hz) significantly increased the probability of perceptual disappearance. In the case of the SfM, tACS in the higher gamma range (60 Hz) increased the number of perceptual reversals. In summary, our results suggest that the percept-correlated oscillatory activity in the beta range observed in previous studies might be related to visual attention and/or sensorimotor processes, but is not causally linked to the percept. In contrast, transient synchronization of widespread neuronal populations in the gamma range seems to play a causal role in creating a coherent percept.

Function of the positive feedback circuitry within layer 4 of the barrel cortex

Omer Revah, Tatjana Tchumachenko², Fred Wolf^{3,4}, Michael Gutnick¹

¹School of Veterinary Medicine, The Hebrew University of Jerusalem, Rehovot 76100, Israel.

²Center for Theoretical Neuroscience, Columbia University, 1051 Riverside Drive, new York City, NY 10032.

³Department of Nonlinear Dynamics, Max Planck Institute for Dynamics and Self-Organization, Goettingen, Germany.

⁴Bernstein Center for Computational Neuroscience Goettingen, Goettingen, Germany.

In rodents, the highly organized somatosensory pathway from the face is reflected in cortical layer 4 by anatomically well-defined barrels, each of which corresponds to a single whisker. Eighty percent of the neurons in layer 4 are excitatory cells, most of which are spiny stellate cells whose dendrites are confined to the barrel and whose axons project to other cells within the barrel and to layers 2 and 3. Only about 15 % of the excitatory input to these cells is of thalamic origin, while the remaining 85% is contributed by other cortical cells, largely from the same barrel. Several studies have shown that these recurrent excitatory inputs have an unusually large NMDA receptor-mediated component. Our laboratory showed that spiny stellate cells possess NMDA receptors which have a decreased voltage-dependent Mg^{2+} block, such that they are active at resting potential (Fleiderovich et al. 1998). A subsequent study (Binstok et al. 2006) demonstrated that this reflects the presence of the NR2C subunit in these synapses. We now propose that one function of this NMDA receptor-mediated positive feedback within the barrel is to enhance the dynamic gain of the layer 4 network by increasing the correlation time of the synaptic noise in the cell at membrane potentials below spike threshold. In tangential slices of barrel cortex which only contain layer 4, brief periods of spontaneous activity were induced by briefly illuminating caged NMDA. Voltage clamp recordings allowed us to determine the dynamic characteristics of the subthreshold current noise. For comparison, equivalent experiments were carried out on layer 2-3 pyramidal cells in coronal slices. Interestingly, although the active periods were accompanied by considerable inhibitory synaptic conductance, almost no inhibitory synaptic current contributed to the noise at subthreshold voltages. We suggest that, as predicted theoretically (Tchumatchenko et al. 2011, Tchumatchenko and Wolf, 2011), the slower correlation time imposed by the prominent NMDA component is associated with an enhanced ability of the layer 4 network as a whole to respond quickly to a wide range of input frequencies, despite the fact that any single neuron has a very low firing rate.

* Email: omerrevah@gmail.com

Modulation of hippocampal assemblies by repetitive activation of granule cells *in vitro*

Martin Keller, Andreas Draguhn¹, Susanne Reichinnek¹, Martin Both¹

¹Institut für Physiologie und Pathophysiologie, AG Draguhn, Im Neuenheimer Feld 326, 69120 Heidelberg, Germany

Cognitive functions are associated with complex patterns of participating neurons which form defined assemblies in neuronal networks. In the hippocampus, spatial memory formation requires highly reproducible activation of such functionally coupled sets of neurons. A major input pathway from the entorhinal cortex to the hippocampal formation includes the dentate gyrus (DG). This nucleus is characterized by a very high number of sparsely firing granule cells enabling multiple different activation patterns. Recent evidence indicates that newborn granule cells support separation of input patterns, while mature neurons play a role for pattern completion. It is unknown, however, how the DG affects memory-related assembly formation in the hippocampus proper.

We studied activity patterns in mouse hippocampal slices *in vitro* which generate spontaneous sharp wave ripple complexes (SPW-R). This pattern of network activity supports memory consolidation and involves repetitive activation of functionally coupled neurons (re-play). We asked whether such functional assemblies can be modulated by repetitive firing of defined sets of granule cells. Tetrode recordings and subsequent sorting of SPW-R waveforms by self-organizing maps allowed identification of distinct assemblies in CA3 and CA1. Weak stimulation of distinct sets of granule cells elicited transient field potentials closely resembling spontaneous SPW-R. Sorting by our unbiased algorithm revealed that these events were indeed similar to spontaneous network discharges and were confined to a sub-set of spontaneous events, indicating activation of defined assemblies. Stimulation of different sites within DG evoked clearly different downstream response patterns. Repetitive extracellular stimulation within DG appeared to modulate the variability of evoked events in CA3 and CA1 in an input-specific manner. Our data suggest a modulating impact of the DG for pattern formation within the hippocampus proper. Supported by the DFG (SFB 636, B6).

Connectivity analysis in the thoracic ganglia between local interneurons and DUM neurons

Leonard Nadler, Hans-Joachim Pflüger¹

¹Freie Universität Berlin, Institut für Biologie - Neurobiologie, Königin-Luise-Straße 28-30, 14195 Berlin, Germany

Octopamine, the invertebrate analogue of the catecholamine noradrenaline in vertebrates, is known to act as a transmitter, a neurohormone, and a neuromodulator. The locust thoracic ganglia contain a defined cluster of octopaminergic efferent dorsal unpaired median (DUM) neurones, which possess axons that run through the peripheral nerves of thoracic ganglia. Due to their innervation of either wing or leg muscles and due to their different responses to sensory stimuli, these DUM neurones can be functionally subdivided into either the wing or the leg group DUM neurones. Even though some of the sensory pathways are known in detail, none of the studies have so far been able to find any presynaptic neurone that directly innervates efferent thoracic DUM neurones. In contrast to sensory neurones, little to none is known about possible connections of local spiking and non-spiking interneurones to DUM neurones. The aim of my study is to find and describe presynaptic neurones that directly activate or inhibit DUM cells in the thoracic ganglia. By using paired intracellular recordings we observe the responses of efferent thoracic DUM neurones while manipulating the activity in a local spiking or non-spiking interneurone. For further characterization and identification of the recorded targets, all cells are labelled and their morphology visualized with the use of image processing software.

Functional connectivity of layer II/III GABAergic Martinotti cells in the primary somatosensory (barrel) cortex of mice

Florian Walker, Mirko Witte¹, Martin Möck¹, Jochen Staiger¹

¹Universitätsmedizin Göttingen, Neuroanatomie, Kreuzberggring 36, 37075 Göttingen, Germany

GABA releasing interneurons play a crucial role in information processing within the neocortex and are directly integrated in the circuitry of rodent primary somatosensory cortex, also known as barrel cortex. Martinotti cells, a well-defined subclass of GABAergic interneurons, modulate the dendritic excitation of pyramidal cells, thereby having direct influence on barrel cortex output structures. One prominent feature of these cells is that they receive dense local excitation from pyramidal cells, which makes them suitable for feedback and lateral inhibition but also for “interfacing” the lemniscal and paralemniscal pathways, which process different aspects of tactile information resulting from whisking behaviour. In addition, *in vivo* data also showed that Martinotti cells receive inhibition during active whisking. The neocortical origin of these inputs, especially of the inhibitory, to the Martinotti cells is still unknown. In this study a combination of whole-cell patch clamp and local photolysis of caged glutamate in acute brain slices has been used to detect local neocortical circuits responsible for the excitation and/or inhibition of Martinotti cells. The resulting data indicates that these cells receive local inhibition from cells of layer II/III and in addition inhibition from cells in layer V. To identify distinct cell types responsible for the inhibition of Martinotti cells, mouse cre-driver lines were utilized which, besides expressing GFP in Martinotti cells, exhibited a second fluorescent marker (PV, VIP or SOM) in different subtypes of inhibitory interneurons. Moreover, caged GABA was employed to define the spatial distribution of GABA_A receptors, concluding that these receptors can be found around the soma of Martinotti cells. In a next step we will perform paired recordings from Martinotti cells and their “upstream” connected inhibitory interneurons to identify and characterize those presynaptic GABAergic neurons. Our results will contribute to a model of processing sensory information in the barrel cortex (e.g. “interfacing” the lemniscal and paralemniscal pathways) and will improve the understanding of the GABAergic interneuron network.

Fast network oscillations in the lateral septum in vivo

Tatiana Korotkova, Natalia P. Denisova¹, Alexey Ponomarenko¹

¹Leibniz-Institut fuer Molekulare Pharmakologie (FMP)/NeuroCure Exzellenzcluster, AG Behavioural Neurodynamics, Charité Campus Mitte, Charitéplatz 1; Intern: Virchowweg 6, Geb.2360, Raum 02-248, 10117 Berlin, Germany

Animal's behaviour relies on the processing of environmental cues and signals about bodily state yet physiology of their coordination remains poorly understood. Hippocampal and cortical information is relayed to hypothalamus and midbrain in rodents and other mammals mainly via the lateral septal nucleus (LS). We used high-density single and multi-site electrophysiological registration of local field potentials and of neuronal discharge in behaving mice to study network synchronization in LS and its coordination with inputs from the medial prefrontal cortex (mPFC) and hippocampus. Local field potentials (LFP) and neuronal discharge in LS displayed intermittent episodes (40-120 ms duration) of synchronization at frequencies between 40 and 90 Hz. These fast oscillations were behavioral state dependent and coordinated within LS. Moreover, gamma oscillations in LS were coherent with concurrently recorded gamma activity in mPFC and, less prominently, in the hippocampus during slow- and theta-rhythmic epochs respectively. Neuronal activity in LS was modulated by locally recorded LFP gamma oscillations: the discharge of the vast majority of recorded cells was significantly modulated by the locally recorded rhythm. As a population LS units fired near troughs of gamma cycles. LFP and the neuronal discharge recorded simultaneously from LS and mPFC displayed coordinated patterns of activity between the two regions in the gamma frequency band. Furthermore, our recordings of LFP and neuronal activity in LS in novel and familiar environments and during exploration of novel objects suggest experience-dependence of network synchrony in LS and its potential relevance for shaping behavioral responses to novelty processed by hippocampus and mPFC.

The neuronal circuit underlying timing of eclosion behavior in *Drosophila*.

Mareike Selcho, Kouji Yasuyama², Ronja Hensgen³, Christian Wegener⁴

^{1,4}University of Würzburg, Biocenter, Neurobiology and Genetics, Am Hubland, 97074 Würzburg, Germany; ²Kawasaki Medical School, Natural Sciences, Biology, 577 Matsushima, 701-0192 Kurashiki, Japan; ³University of Marburg, Department of Biology, Neurobiology/Ethology, 35032 Marburg, Germany

Neuropeptide release is often rhythmic, potentially coupled to circadian oscillators in the brain. The neuronal mechanisms underlying clock-controlled release of neuropeptides is however only little understood. Eclosion in the fruit fly *Drosophila* is a classical example for both: peptide-orchestrated and circadian timed behavior. To understand how peptidergic neurons and clock cells are interacting to time *Drosophila* eclosion it is necessary to anatomically characterize the underlying neuronal circuit. We dissected the projection patterns of *CCAP*(crustacean cardioactive peptide)-*GAL4*-positive neurons on the single-cell level, as these neurons were shown to be involved in eclosion (Park et al., 2003; Lahr et al., 2012). Using behavioral experiments, we identified another peptide involved in eclosion: *PTTH* (prothoracicotropic hormone). On the light-microscopic level, we found potential overlap of PDF-immunoreactive cells with *CCAP-GAL4*-positive and *ptth-GAL4*-positive neurons, respectively. To confirm these potential synaptic contacts we use immuno-electron microscopy. Our first results identified potential circuit connections between PDF-positive and *CCAP* neurons. Their functional significance for the circadian control of eclosion will now be tested on the behavioral level.

Photoperiod affects physiological responses of circadian pacemaker neurons in the Madeira cockroach *Rhyparobia maderae*

Hongying Wei, El-Sayed Baz¹, Monika Stengl¹

¹FB 10, Biology, Animal Physiology, University of Kassel, Heinrich Plett Str.40, 34132 Kassel, Germany

Little is known about photoperiod-dependent plasticity of the circadian system. In the Madeira cockroach *Rhyparobia maderae* circadian pacemaker neurons of the accessory medulla are spontaneously active being either activated or inhibited with rises of the extracellular Ca^{2+} concentration. Their spontaneous activity appears to be a prerequisite to neuropeptide-dependent ensemble-formation and gating of clock-outputs. Here, we searched for physiological changes in single, isolated circadian pacemaker neurons of Madeira cockroaches either raised in 12:12, 16:8, or 8:16 light: dark cycles. Using Ca^{2+} imaging, 7 different response types of spontaneously active circadian pacemaker neurons were distinguished in different extracellular Ca^{2+} concentrations. The percentage of different response types (type-percentage vectors) was highly photoperiod-specific and reproducible. It reliably predicted the different photoperiods and, thus, encoded short- and long-day information. Thus, exposure to different photoperiods in development not only changes the network of the circadian clock, but also alters physiological responses of single circadian pacemaker neurons via so far unknown mechanisms. Currently, it is examined whether the observed plasticity of the circadian system can also be induced transiently in adult insects as an adaptive property to transient changes in the environment. Furthermore, it is searched for a photoperiodic change in responses to hypothetical neurotransmitters of photic entrainment pathways as a possible basis for these photoperiod-specific physiological changes. [Supported by DFG grant STE531/21-1 to MS]

Impact of chronic nicotine treatment on hippocampal oscillatory activity in a G72 transgenic mouse model for schizophrenia

Andreas Lundt, Boris Hamsch², David-Marian Otte², Karl Broich¹, Anna Papazoglou¹,
Andreas Zimmer², Marco Weiergräber¹

¹Federal Institute for Drugs and Medical Devices, Cellular and Systemic Neurophysiology, Kurt-Georg-Kiesinger Allee 3, 53175 Bonn, Germany

¹Institute of Molecular Psychiatry, University of Bonn, Sigmund Freud Str. 25
53127 Bonn, Germany

Numerous CNS related cognitive processes are associated with complex hippocampal oscillatory activity. A major deficit in schizophrenia patients is cognitive impairment, which might be induced by dysrhythmia of interacting brain areas. A highly associated gene for schizophrenia is the primate specific gene locus G72/G30, which encodes the 153aa protein LG72. Humanized BAC transgenic mice expressing the G72/G30 gene locus exhibit cognitive and behavioral deficits related to schizophrenia symptoms. Several studies suggest that nicotine treatment can reduce cognitive impairment in schizophrenia patients. Unpublished data on prepulse inhibition, working memory and social recognition has shown that G72 transgenic mice chronically treated with nicotine improved cognitive function. Furthermore, nicotine treatment increased $\alpha 7$ -nAChR density in the dentate gyrus G72 transgenic mice.

To investigate the impact of chronic nicotine treatment on hippocampal oscillatory activity and rhythmical interdependence of both hippocampus and motor cortex we performed radiotelemetric video-EEG-recordings in nicotine and 0.9% NaCl treated G72 transgenic mice and controls. Electrodes were placed in the dentate gyrus (DG) of the hippocampus and surface electrodes in the (primary and secondary) motor cortex. Nicotine was administered chronically with 24 mg/kg/d for 10 days using subcutaneous osmotic pumps. Oscillatory EEG activity was analyzed using complex wavelet based analysis prior to, during and post nicotine administration. Our results demonstrate that nicotine treatment influences complex hippocampal rhythmicity in G72 transgenic mice.

The Cav 2.3 R-type channel is a Modulator of Rodent Sleep Architecture

Magdalena Elisabeth Siwek, Anna Papazoglou¹, Marco Weiergräber¹, Karl Broich¹

¹Federal Institute for Drugs and medical Devices, 5; Cellular and systemic Neurophysiology, Kurt-Georg-Kiesinger-Allee 3, 53175 Bonn, Germany

Voltage-gated Ca²⁺ channels (VGCCs) play an important role in mediating thalamocortical rhythmicity, thus controlling vigilance and slow wave sleep. On the cellular and systemic electrophysiological level, low-voltage activated (LVA) Cav3 T-type Ca²⁺ channel have been related to thalamic rebound burst firing and the generation of non-rapid eye movement sleep (NREM sleep). High-voltage activated (HVA) Cav1 L-type Ca²⁺ channels on the opposite favour the tonic mode of action associated with higher levels of vigilance. However, the role of the HVA Non-L-type Cav2.3 Ca²⁺ channel which is predominately expressed in the reticular thalamic nucleus (RTN) still remains unclear. Recently, Cav2.3 knock-out mice were reported to exhibit altered spike-wave discharge and absence seizure susceptibility. These findings were supported by the observation that Cav2.3 mediated Ca²⁺ influx into RTN neurons can trigger small conductance calcium-activated potassium channels (SK2) currents initiating the next hyperpolarization-activated cyclic nucleotide-gated (HCN) and reprimed T-type Ca²⁺ current mediated burst cycle. Based on these results we analyzed the role of Cav2.3 channels in spontaneous and artificial, urethane induced sleep in Cav2.3 knock-out mice and C57Bl/6J wild-type controls by using implantable video-EEG radiotelemetry. Radiotelemetry provides monitoring and collecting data from conscious, freely moving laboratory animals under experimental injection regimes.

Our results demonstrate that slow-wave sleep is significantly altered in both spontaneous and artificial sleep as indicated by earlier patch-clamp experiments. This is the first study to describe a functional role of Cav2.3 R-type Ca²⁺ channels in regulating mammalian sleep architecture.

Task-dependent activation of thalamo-cortical networks with tACS

Christiane Weinrich, Carsten Schmidt-Samoa², Peter Dechent³, Melanie Wilke⁴,
Mathias Baehr⁴

¹UMG Neurology Goettingen, Cognitive Neurology, Robert-Koch-Straße 40, 37073 Goettingen Goettingen, Germany

Synchronous oscillatory activity among neuronal populations has been linked to a wide range of brain functions including memory, perception, attention and motor behavior (Engel et al., 2001). Transcranial alternating current stimulation (tACS) is thought to interact with ongoing rhythmic activity in a frequency specific manner and may thus be an important tool to investigate the relationship between oscillatory activity and brain function. On the behavioral level, tACS studies in humans revealed that stimulation in the beta band (~20 Hz) over specific regions induces phosphenes (Kanai et al., 2008), somatosensory sensations (Feurra et al., 2011) and slows movements (Joundi et al., 2012).

The goal of the present study was to investigate the neural network changes that occur while driving oscillatory activity by means of tACS. To this end, we employed a combination of fMRI and tACS and compared frequency- and task-dependent effects of tACS in healthy human subjects. Subjects (N = 11) performed two different tasks, a video viewing task and a motor task while short periods of tACS (12 seconds, 1500µA, electrode position: Pcz, Oz) were applied at different frequencies (4Hz, 16Hz, 80Hz) in a pseudorandomized order.

The strongest effect of tACS on BOLD activity was observed with stimulation in the beta (16Hz) frequency band. Specifically, we found that tACS in the beta range induces a BOLD activity increase in fronto-parietal networks (superior, middle, inferior frontal gyrus, intraparietal sulcus (IPS)) and in the basal ganglia (putamen, thalamus and caudate nucleus). While these activity patterns were observed during the video viewing task, beta-induced activity in the basal ganglia appeared to be suppressed during the motor task. This absence of activation in the motor task may reflect the inhibition of beta activity that is typically observed during execution of voluntary movements. Taken together, the combination of fMRI and tACS revealed frequency, task and region specific evoked BOLD activity and may thus provide a useful tool to gauge the functional integrity of cortical and subcortical networks. In the future this may also be applied to parkinson patients where abnormally synchronized oscillatory activity in the beta band (~20 Hz) correlates with motor deficits.

Optimized temporally deconvolved Ca^{2+} imaging reveals scale-free topology of CA1 hippocampal assemblies

Thomas Pfeiffer, Susanne Reichinnek¹, Andreas Draguhn¹, Martin Both¹

¹Heidelberg University, Institute for Physiology and Pathophysiology, Im Neuenheimer Feld 326, 69120 Heidelberg, Germany

Hippocampal activity is characterized by the coordinated firing of a subset of neurons. Such neuronal assemblies can be either driven by external stimuli to form new memory traces or be reactivated by intrinsic mechanisms to reactivate and consolidate old memories. Hippocampal network oscillations orchestrate this coherent activity. One key question is how the topology, i.e. the functional connectivity of neuronal networks supports their desired function. Recently, this has been addressed by characterizing the intrinsic properties for the highly recurrently connected CA3 region using organotypic slice cultures and Ca^{2+} imaging.

In the present study, we aimed to determine the properties of CA1 hippocampal assemblies at high temporal and multiple single cell resolution. To do this, we performed Ca^{2+} imaging using the chemical fluorescent Ca^{2+} indicator Oregon Green BAPTA 1-AM. To achieve more physiological conditions, we used acute hippocampal slices that were recorded in a so-called interface chamber. To faithfully reconstruct firing patterns of multiple neurons in the field of view, we optimized deconvolution-based detection of action potential associated Ca^{2+} events.

Our approach outperformed currently available detection algorithms by its sensitivity and robustness. Applying it in combination with subsequent sophisticated network analysis, we were able to show that acute hippocampal slices contained a median of 9 CA1 neuronal assemblies with a median size of 4 neurons. This low neuron number is due to the recording restriction to one optical plane and a small field of view. Notably, our data provided evidence that CA1 neuronal assemblies have a scale-free topology. That ascribes them 'small world' properties, with very local connectivity and super-connected hubs with long-range connections. Hence, scale-free topology in CA1 neuronal assemblies would ensure cost-efficient signal transfer with avoidance of signal jamming and/or interference.

The presented temporally deconvolved Ca^{2+} imaging in this study provides a promising platform for further development and might be of major interest for the neuronal Ca^{2+} imaging community.

Identification of closer-interneurons of the song pattern generator in the cricket (*Gryllus bimaculatus* DeGeer)

Joaquim Pedro Jacob, Berthold Hedwig¹

¹University of Cambridge, Department of Zoology, Downing Street, CB2 3EJ Cambridge, United Kingdom

²Champalimaud Neuroscience Program, Champalimaud Centre for the Unknown, Doca de Pedrouços, 1400-038 Lisboa, Portugal

Cricket singing behaviour has been shaped by sexual selection for the generation of species-specific communication signals. Male crickets produce calling songs by the rhythmic activity of wing-opener and closer motoneurons. Singing depends on the activity of a central pattern generator (CPG) network, located in the abdominal ganglia and composed of opener- and closer-interneurons (Schöneich and Hedwig 2012).

This study aims to analyse abdominal ascending closer-interneurons which have not yet been identified in detail. In *Gryllus bimaculatus* fictive singing will be elicited by microinjection of eserine in the brain, to drive descending command neurons, which are involved in the activation of the singing CPG.

After severing all thoracic sensory and motor nerves, the motor pattern of fictive singing will be recorded from the mesothoracic wing nerve 3A revealing the rhythmic spike activity of wing-opener and wing-closer motoneurons. Sharp microelectrode intracellular recordings will be used to explore the abdominal ganglia, especially A3, for local and intersegmental closer interneurons. The impact of the closer-interneurons on the song pattern will be addressed by intracellular current injection and their morphological structure by staining with neurobiotin or fluorescent dyes.

We predict the existence of several closer-interneurons in the abdominal ganglia, of which some have projections towards the wing motor network in the mesothoracic ganglion. It is expected that these interneurons will be inhibited by the opener-interneurons and that a post-inhibitory rebound effect may drive the excitation of the closer-interneurons.

This work will be important to establish the functional circuitry of the singing network and the interactions between the opener- and closer-interneurons. (Funded by Champalimaud Neuroscience Program (SFRH/BD/51901/2012)).

On the impact of oscillatory synchrony on directed functional connectivity metrics: a network-model-based study

Agostina Palmigiano, Demian Battaglia^{1,2}, Annette Witt^{1,2,3}, Theo Geisel^{1,2}

¹Max Planck Institute for Dynamics and Self-Organization, Non Linear Dynamics, Am Fassberg 17, 37077 Goettingen, Germany

²Bernstein Center for Computational Neuroscience, Germany

³German Primate Center, Germany

Perception, cognition and behavior require flexible communication and coordination between brain circuits. Experimental and theoretical evidence (Womelsdorf et al. 2007; Battaglia et al., 2012) show that phase locking between the oscillatory activity of different brain areas or local circuits may underlie the self-organized instantiation of effective communication channels. From a data analysis perspective, causal influences between different neuronal populations are often inferred from time series of neural activity obtained through electrophysiological recordings or imaging techniques using methods like Granger Causality or Transfer Entropy. However, the depiction of inter-areal interactions provided by such indirect "black-box" approaches is difficult to interpret, because the underlying network dynamics associated to the recorded signals is known only partially or is completely hidden. Furthermore different metrics are not guaranteed but in special conditions to infer matching causal connectivities (aka directed functional connectivities). We consider here the dynamics of a toy system of two coupled (unidirectionally or bidirectionally) neural populations, described as large networks of spiking excitatory and inhibitory neurons with realistic heterogeneous parameters. By varying systematically the degree of synchronization of the resulting network activity and the strength of inter-population coupling, we explore the performance in different dynamical regimes of different causality metrics in inferring the underlying inter-population coupling from semi-realistic synthetic spike trains, LFPs and other imaging signals with different spatial and temporal resolutions. More specifically, we identify under which conditions linear techniques fail in providing a correct inference of the ongoing population interaction and we comment on possible practical strategies to overcome their limitations.

Acknowledgements

This project is supported by the grant BMBF Grant 01GQ1005B (BCCN Goettingen)

References

- [1] Womelsdorf T et al (2007) Science 316: 1609-1612.
- [2] Buehlmann A, Deco G (2010) PLoS Comp Biol 6.
- [3] Battaglia D, Witt A, Wolf F, Geisel T (2012) PLoS Comp Biol (in press).
- [4] Barnett L, Barrett AB, Seth AK (2009) Phys Rev Lett 103:238701.

Applying Internal Models to Gait-Aware Neuro-Control in a Knee-Ankle-Foot-Orthosis

Jan-Matthias Braun, Poramate Manoonpong^{1,3,4}, Timo von Marcard², Markus Tüttemann², Florentin Wörgötter^{1,3,4}, Bernhard Graimann^{2,3}

¹ III. Physical Institute – Biophysics, Georg-August University Göttingen, Germany

² R&D, Otto Bock HealthCare GmbH, Duderstadt, Germany

³ Bernstein Center for Computational Neuroscience, Göttingen, Germany

⁴ Bernstein Focus Neurotechnology Göttingen, Germany

A Knee-Ankle-Foot-Orthosis (KAFO) is a modular lower-extremity orthosis prescribed to people with gait disability. The KAFO should support, correct and assist the movement of the corresponding affected joints. Traditional KAFOs are restricted by a gait depending switch of the joints. The switch is based on (electro-) mechanic non-adaptive switches; therefore, common disturbances (floor unevenness, obstacles, ramps) cannot be mastered in a satisfactory way. Novel approaches include active elements into the orthosis, which do not directly act on the movement. Instead they adjust the compliance leading to new challenges for the controller of such actuators, which are difficult to handle with traditional approaches.

To take advantage of the fine grained control of the active element and overcome shortcomings of traditional control approaches, adaptive methods like artificial neural networks (ANN) can be applied. These methods can cope with the flexibility of the active elements and allow an individual support of a wider range of patients. The high neuromuscular variability within a specific patient group (Yakimovich et al., 2009) creates specific constraints on the support supplied by the orthosis. Therefore, the development of advanced devices is imposing the need for individual (online) adaptation of gait parameters to allow adaptation (1) to changing environments like slopes, stairs etc. as well as to gait parameters like stride length/frequency and (2) to the individual patients with respect to physiological conditions. To do so, we have employed a reflexive, modular neuro-controller inspired by the RunBot controller (Manoonpong et al., 2007), embedded to a KAFO based on a controllable hydraulic damper, derived from OttoBock's C-Leg®.

This study evaluates internal motion models implemented with artificial neural networks to distinguish different gaits as the patient reacts to changes in his environment. A set of these models have been trained to predict a certain gait, each, like stairs or slopes. Investigated is the the controller's ability to detect gait changes and the current gait using these models. Thereby we focus on the ability to make a decision early in the first step of the step sequence following a gait change while the rate of misclassification should diminish. These properties reflect that the process of gait parameter adaptation should take no more than one step and supports the current gait in an optimal manner.

Our preliminary results indicate, that the motion models are an accurate and fast adaptive method for this purpose. It fits well into and extends the used paradigm of adaptive modular neuro-control.

Acknowledgements: This research was supported by the BMBF-funded BFNT Göttingen with grant number 01GQ0810 (project 3A) and BCCN Göttingen with grant number 01GQ1005A (project D1) and the Emmy Noether Program (DFG, MA4464/3-1).

Restoration of impaired functional coupling in the amygdalo-hippocampal-cortical circuitry in NCAM deficient mice by partial NMDA receptor agonist D-cycloserine

Oleg Senkov, Gerhard Engler⁵, Melitta Schachner^{2,3}, Alexander Dityatev^{1,4}, Andreas K. Engel⁵

¹Molekulare Neuroplastizität, Deutsches Zentrum für Neurodegenerative Erkrankungen (DZNE), Magdeburg, Germany;

²Zentrum für Molekulare Neurobiologie, Universitätsklinikum Hamburg-Eppendorf, Hamburg, Germany;

³Department of Cell Biology and Neuroscience, Rutgers University, Piscataway, USA;

⁴Department of Neuroscience and Brain Technologies, Italian Institute of Technology, Genova, Italy;

⁵Institut für Neurophysiologie und Pathophysiologie, Universitätsklinikum Hamburg-Eppendorf, Hamburg, Germany

Abnormal information transfer within define brain circuits is a cause of impaired cognition, learning and memory. The hippocampus in conjunction with the amygdala and related cortical structures, orchestrates fear-driven encoding of memory traces and their disrupted crosstalk may underlie brain disorders such as schizophrenia, Alzheimer's disease and post-traumatic stress and anxiety disorders. Here, we investigated mice lacking the neural cell adhesion molecule (NCAM), expression of which is altered in schizophrenic (Barbeau et al., 1995, PNAS; Vawter et al., 1998, Exp Neurol.; Gilabert-Juan et al., 2012, Neurosci Lett.) and Alzheimer's disease patients (Aisa et al., 2010) and in response to stress (Sandi et al., 2005, Biol Psychiatry; Bisaz et al., 2011, Hippocampus; Gilabert-Juan et al., 2011, Exp Neurol). NCAM knockout (KO) mice have profound deficits in fear conditioning and synaptic plasticity (Senkov et al., 2006, J Neurosci) due to impaired balance in the signaling through synaptic GluN2A- versus extrasynaptic GluN2B-containing NMDA receptors (Kochlamazashvili et al., 2010, 2012, J Neurosci). Here, we searched for neuronal activity correlates of impaired fear conditioning in NCAM KO mice and for strategies to rescue these impairments. We simultaneously recorded local field potentials from four different brain structures while freely-moving mice were exposed to the conditioned context. Patterns of neuronal activity in the amygdala, hippocampus, auditory and visual cortices were highly synchronized at low theta frequency (4-8 Hz) and correlated with freezing behavior. High theta (8-12 Hz) was prominent during exploration. NCAM KO mice showed an altered phase and reduced amplitude coherence of theta oscillations between hippocampus, amygdala and cortices. Power of gamma (30-40 Hz) oscillations was decreased in the amygdala of NCAM KO mice. Pretraining injection of D-cycloserine (20 mg/kg, i.p.), as a partial agonist at the glycine site of NMDA receptors, predominantly facilitating transmission through GluN2A receptors, could restore contextual discrimination of fear memory and augment synchronous activity in the amygdalo-hippocampal circuitry, and normalize hippocampal theta and amygdalar theta/gamma oscillations in NCAM KO mice. On the contrary, pretesting application of muscarinic acetylcholine receptors antagonist scopolamine (10 mg/kg, i.p.) could disrupt theta and gamma power and coherence in different brain areas and inhibit retrieval of fear memory in wild type mice. These data significantly extend previous observations of reduced amygdalo-hippocampal theta synchronization in NCAM KO mice (Albrecht et al., 2010, Int J Neuropsychopharmacol) and implicate theta and gamma oscillations and their synchronization between distant brain structures in information flow necessary for formation/retrieval of fear memories. Furthermore, we demonstrate how pharmacologically augment or

disrupt this synchronization and memory.

Investigation into O-LM cell recruitment during hippocampal ripples *in vitro*

Maria Pangalos, José R. Donoso^{2,3}, Jochen Winterer¹, Aleksandar R. Zivkovic¹,
Richard Kempter^{2,3}, Nikolaus Maier¹, Dietmar Schmitz^{1,2,3,4,5}

¹Neurowissenschaftliches Forschungszentrum, Charité-Universitätsmedizin Berlin, AG Prof. Schmitz, Virchowweg 6 - Charitéplatz 1, 10117 Berlin, Germany

²Institute for Theoretical Biology, Humboldt-Universität zu Berlin, Germany

³Bernstein Center for Computational Neuroscience Berlin

⁴Cluster of Excellence 'NeuroCure', Berlin

⁵Deutsches Zentrum für Neurodegenerative Erkrankungen in der Helmholtz-Gemeinschaft

Hippocampal ripple oscillations at ~200 Hz, which are associated with sharp waves have been implicated in the consolidation of memories. Mechanisms underlying ripples are still under investigation, especially with respect to synaptic involvement of specific cell types. Cell-attached and whole-cell recordings *in vitro* were used to study activity of oriens-lacunosum-moleculare (O-LM) interneurons during sharp wave ripples. Indeed, O-LM cells received synaptic input during ripples that arrived delayed (3.3 ± 0.4 ms) with respect to the maximum amplitude of the ripple in the local field potential and was locked to the ascending phase ($209^\circ \pm 6^\circ$) of field oscillations. Consistent with the late synaptic input, O-LM cells episodically discharged late during ripples (~5 ms after the ripple maximum), and firing was phase-locked ($249^\circ \pm 12^\circ$) with the field oscillation. In summary, O-LM neurons are recruited during sharp wave-associated ripples, which suggests a new role of this cell type during ripples.

Decoding Spatial Information from Myoelectric Signals for Control of Transradial Prostheses"

J. Michael Herrmann, David Hofmann², Dario Farina³

¹University of Edinburgh, Institute for Perception, Action and Behaviour, 10 Crichton St, EH10 4ER Edinburgh, United Kingdom

²Bernstein Focus Neurotechnology and MPI for Dynamics and Self-Organisation, Am Fassberg 17, 37077 Göttingen, Germany

³Dept. of Neurorehabilitation Engineering, University Medical Center, Georg August University, Göttingen, Germany

Pattern recognition methods for myoelectric prosthesis control were studied intensively for the last decades and still are a very active field of research. In this approaches muscle activity is recorded from electrodes placed on the skin surface while a certain set of static contractions (classes) is performed. The recent development of high density surface electrode arrays for myoelectric recordings facilitates the possibility of spatial filter application to improve classification accuracy. Previous studies have shown that the application of spatial filters leads to significant improvement of classification accuracy [Huang2009]. Here spatial filters are pre-defined filter masks, and are thus data independent. In contrast, Hahne et al. [Hahne2012] employed the common spatial patterns (CSP) method to compute data dependent spatial filter masks. They have shown that CSP outperforms widely used bipolar filters and shows robustness with respect to additive white noise.

In this study we show that blind source separation (BSS) techniques, e.g. independent component analysis and second order blind identification (SOBI), outperform spatial filter methods [Hahne2012, Huang2009]. For our study we recorded data from three able bodied subjects performing eight static contractions (hand open/close, wrist pronation/supination/flexion/extension/abduction/adduction) for 5s. The whole procedure is repeated 10 times. We find that performance differences between methods become more pronounced, if the dynamic signal phase, produced during the onset of the static contraction, is included. In this situation pre-processing with SOBI gives the best results, while for the static signal phase most tested BSS methods and spatial filters produced a comparable performance. Furthermore, we show that relative improvements, from non-filtered to filtered signals, are higher for very small feature calculation time window lengths (20-80ms) using simply root mean square as signal feature. For instance improvements from 92.5% to 98% accuracy are achieved for a time window of 20ms and signals with dynamic phase removed as are used by most studies in the field. The tested BSS methods also show better robustness against white noise than standard spatial filters as for example the Laplace filter. The quality of the reported results meet the requirements of practical applications, although problems arising from non-stationarity of the signal due to electrode shifts, different positions of the upper arm and muscle fatigue need further investigation.

Integration and Segregation of choice relevant information across state transitions in macaque prefrontal cortex.

Stephanie Westendorff, Daniel Kaping¹, Martin Vinck², Stefan Everling³, Thilo Womelsdorf^{1,3}

¹York University, Laboratory for Attentional Control and Neural Circuits, Toronto, Canada

²University of Amsterdam, Amsterdam, Netherlands

³Dept. of Physiol. and Pharmacology; Dept. of Psychology, Brain and Mind Institute; Western Univ., London, ON, Canada

Multiple brain areas within the primate prefrontal cortex are implicated to subserve the control of attention as well as to guide decision making (Rushworth et al., 2011, Neuron). Covert attentional stimulus selection typically precedes the overt choice of the so selected representation. It has remained unresolved, however, how neurons ensuring focused attention on relevant stimuli, and neurons integrating decision variables about stimuli are interacting during goal directed behavior. Previous studies suggest that the local integration and temporal coordination of distinct functions is subserved by rhythmic synchronization among the constituent neurons. We therefore set out to test whether selective synchronization patterns of single neurons across medial and lateral prefrontal cortex (PFC) subdivisions allow to identify the integration or segregation of attentional or choice related processes.

We recorded neuronal activity in PFC of two macaque monkeys trained on a selective attention task and quantified spike to LFP synchronization patterns during two distinct processing states: (1) A selective “attentional state” in which monkeys sustained focused attention on one of two peripheral stimuli, and (2) during a “decision point” requiring a 2-discrimination forced choice about a transient clockwise/counterclockwise rotation of the attended target stimulus.

We found that a large proportion of single neurons (~20-25%) reliably phase synchronized their spiking responses to the LFP across a broad range of frequencies during attentional states and during the decision period.

During both, attention and decision epochs, about 25% of neurons with significant phase locking synchronized in the classical gamma range (40-70). The percentage of neurons synchronizing to theta/alpha and beta ranged from 10-15% in both epochs. Notably, the populations of neurons synchronizing at gamma / beta in both epochs was largely segregated. Common rhythmic modulation across epochs was restricted to neurons with theta/alpha synchronization.

These results reveal that large subsets of PFC neurons show statistically reliable synchronization and that transitioning between focused attentional and choice processes is evident in switches of synchronization. Apart from segregation of processing by switches of synchronization, the temporal integration of attentional and choice processes may be subserved by neurons with a common theta rhythmic firing.

Strain differences in iTBS rTMS effects on the cortical expression of the calcium-binding protein calbindin in rats

Annika Mix, Alia Benali², Klaus Funke¹

¹Ruhr University Bochum, Department of Neurophysiology, Universitätsstr. 150, 44801 Bochum, Germany

²Center for Integrative Neuroscience, Otfried Müller Str. 25, 72076 Tübingen

Using a rat model to study the cellular effects of repetitive transcranial magnetic stimulation with regard to changes in cortical excitability, we previously described that the intermittent theta-burst protocol (iTBS) induces a profound reduction in the cortical expression of parvalbumin (PV) in Dark Agouti (DA) rats [1]. PV is a calcium-binding protein (CaBP) almost exclusively expressed in fast-spiking inhibitory interneurons. The expression of two other CaBPs expressed in different classes of inhibitory interneurons, Calbindin (CB) and Calretinin (CR), was little or not affected, respectively. By contrast, continuous theta-burst stimulation (cTBS) significantly reduced the number of CB+ neurons while little affecting PV expression and not at all that of CR. These findings indicate that different patterns of theta-burst stimulation may modulate the activity of different classes of cortical inhibitory interneurons and that this could be a reason for the mostly opposite actions of iTBS and cTBS on human cortical excitability. When stimulating rats of different strain - Sprague Dawley (SD) and Long Evans (LE) in addition to Dark Agouti - we found two major differences: i) basal numbers of neurons expressing either PV, CB or CR differ between strains and ii) reduction in the number of CB+ neurons following iTBS differs. Groups of rats (all male and 3 month old) received iTBS with 3000 stimuli in total (either verum or sham), composed as five blocks of 600 stimuli repeated at 15-minute intervals while being sedated with urethane (1.5 g/kg BW), or only one block of 600 stimuli (verum or sham). Other groups received one iTBS block without anaesthesia (verum or sham) but were well adapted to the experimental situation. As in human studies, iTBS was applied as 20 trains of 10 theta-bursts (3 pulses at 50Hz, repeated at 5Hz) repeated at 10-second intervals. Differently, one block of cTBS contains only one uninterrupted theta-burst train lasting 40 seconds. For immunohistochemical analysis rats were sacrificed while deeply anesthetized (0.3 mg/kg BW Pentobarbital-Sodium) due to perfusion with cooled saline followed by 4% paraformaldehyde. Immunohistochemical staining techniques were done as previously described [1].

Results: Reduction in the number of PV+ cells after 5 blocks of iTBS was similar in all three strains examined (-40-50%). By contrast, while CB expression was not changed in DA rats after iTBS, the number of CB+ cells declined by 20-30% in LE rats and even more in SD rats (40-50%). No effect was found for CR. One iTBS block led to a weak usually non-significant reduction of PV+ and CB+ cells. No significant difference was found between iTBS applied to anaesthetized or conscious animals. While basal numbers of PV+ cells relative to all (NeuN-labelled) neurons within one area is quite similar (DA: 7%, SD: 7.5%, LE: 9.5%), numbers of CB+ cells show stronger strain-differences: DA 4%, SD 1.8%, LE 2.6%. These findings demonstrate that inhibitory systems may be either differently developed or show different basal activity levels in rats belonging to different strains and may therefore be also differently sensitive to iTBS.

This study was supported by the Deutsche Forschungsgemeinschaft (FU 256/3-1, SFB 874, TP A4).

[1] Benali A, Trippe J, Weiler E, Mix A, Petrasch-Parwez E, Girzalsky W, Eysel UT, Erdmann R, Funke K (2011) *J Neurosci* 31(4):1193–1203.

Dynamics of cortical circuits with different network topologies

Rainer Engelken, Fred Wolf^{1,2,3,4}, Michael Monteforte^{1,2,3,4}

¹Max-Planck-Institute for Dynamics and Self-Organization, Göttingen, Germany

²Bernstein Center for Computational Neuroscience Göttingen, Germany

³

Faculty of Physics, Georg August University, Göttingen, Germany

⁴

Bernstein Focus: Neurotechnology, Göttingen, Germany

The prevailing explanation for the irregularity of spike sequences in the cerebral cortex is a dynamic balance of excitatory and inhibitory synaptic inputs – the so-called balanced state [1].

Nevertheless its statistical properties are well described by a mean field theory that is independent of the single neuron dynamics, its dynamics is far from being understood. Recently it was found that the stability of the balanced state dynamics depends strongly on the detailed underlying dynamics of individual neurons. Inhibitory networks of leaky integrate-and-fire neurons show stable chaos [2,3], while a balanced network of neurons with an active spike generation mechanism exhibits deterministic extensive chaos [4].

Previous studies of the dynamics of the balanced state used random (Erdős-Rényi) networks. We extended this analysis to arbitrary network topologies and analyzed the entropy production in small world topologies [5], ring networks [6], clustered networks [7], multi-layered networks [8] and topologies with different frequencies of certain network motifs [9]. We derived an analytical expression for the single spike Jacobian containing elements of the coupling matrix, which enabled us to calculate the full Lyapunov spectrum for any desired topology. Using a single neuron model in which action potential onset rapidness [10] and synaptic time constant are adjustable, we simulated the dynamics in numerically exact event-based simulations and calculated Lyapunov spectra, entropy production rate and attractor dimension for a variety of connectivities.

1. van Vreeswijk, C. & Sompolinsky, H. Chaos in neuronal networks with balanced excitatory and inhibitory activity. *Science* 274, 1724-1726 (1996).
2. Jahnke, S., Memmesheimer, R.-M. & Timme, M. How Chaotic is the Balanced State? *Frontiers in Computational Neuroscience* 3, 13 (2009).
3. Zillmer, R., Brunel, N. & Hansel, D. Very long transients, irregular firing, and chaotic dynamics in networks of randomly connected inhibitory integrate-and-fire neurons. *Physical Review E* 79, 031909 (2009).

4. Monteforte, M. & Wolf, F. Dynamical entropy production in spiking neuron networks in the balanced state. *Physical Review Letters* 105, 268104 (2010).
5. Watts, Duncan J.; Strogatz, Steven H. (1998). "Collective dynamics of 'small-world' networks". *Nature* 393 (6684): 440–442.
6. van Vreeswijk C, Sompolinsky H (2005). Irregular activity in large networks of neurons. In: Chow C, Gutkin B, Hansel D, and J Dalibard CM, editors. *Les Houches Lectures LXXX on Methods and models in neurophysics*. London: Elsevier. pp. 341–402.
7. Ashok Litwin-Kumar and Brent Doiron (2012). Slow dynamics and high variability in balanced cortical networks with clustered connections". *Nature Neuroscience*
8. T. C. Potjans, M. Diesmann, (2011) arXiv:1106.5678v1 [q-bio.NC]
9. L. Zhao, B. Beverlin II, T. Netoff, and D. Q. Nykamp. Synchronization from second order network connectivity statistics. *Frontiers in Computational Neuroscience*, 5:28, 2011.
10. Monteforte, M., Wolf, F. (2011) Single cell dynamics determine strength of chaos in collective network dynamics. Twentieth Annual Computational Neuroscience Meeting: CNS 2011

Neuronal Synchronization and Aminergic Modulation of Network Oscillations – Implications for Schizophrenia

André Fisahn, Richard Andersson¹, April Johnston¹

¹Karolinska Institute, KI-Alzheimer Disease Research Center, Retzius väg 8, 17177 Stockholm, Sweden

Recent schizophrenia research has thrown into focus the apparent discrepancy between the reduction of task-driven gamma oscillation activity dominating the human EEG literature and the recently discovered aberrant gamma oscillation-hyperactivity common to animal models and also linked to psychotic symptoms in sporadic human reports. Gamma oscillations (30-80 Hz) are physiological electric activity patterns prevalent in the brain, which are associated with attention, working memory, sensory perception, long-term memory encoding and recall. Importantly, in mental illnesses featuring cognitive disturbances, such as Schizophrenia or Alzheimer's disease, gamma oscillation characteristics are altered. In particular impaired gamma oscillations are associated with treatment-resistant cognitive deficits in schizophrenia. The correct reproduction of these impairments in animal models offers important new translational opportunities in schizophrenia and neuropsychiatric disorders.

All aspects of cognitive function are regulated by the aminergic systems of the brain, which are also associated with mental disorders. Yet little research has been done to understand how aminergic molecules modulate or control gamma oscillations and whether these modulatory systems might offer targets for therapeutic intervention aimed at adjusting gamma oscillation power.

Using combined extracellular local field potential and intracellular patch clamp recordings in in vitro preparations of the rodent hippocampus we found that aminergic neuromodulation is capable to bi-directionally regulate the power of gamma oscillations in the hippocampus, without affecting the overall firing rate of action potentials. Rather, it is the phase-synchronization of pyramidal cell and fast-spiking interneuron activity that is affected by the activation of histamine H3, dopamine D4 or 5HT1A receptors. Our data show that the various schizophrenia hypotheses (dopaminergic, NRG/ErbB4 neurodevelopmental, glutamatergic, GABAergic) may converge on fast-spiking interneurons to influence gamma oscillation levels. This is a potential physiological mechanism by which the gain of signal transmission to downstream targets can be regulated. Targeting this mechanism may have a potential use in future antipsychotic or pro-cognitive pharmaceutical therapy.

Poster Topic

T24: Attention, Motivation, Emotion and Cognition

- T24-1A** An Internal Representation of Zero Yaw Torque in *Drosophila melanogaster*
Franziska Toepfer, Martin Heisenberg, Reinhard Wolf
- T24-2A** Risk-seeking behavior in monkeys is modulated by effort in a spatial decision task
Adán Ulises Domínguez Vargas, Annika Grass, Stefan Treue, Melanie Wilke, Igor Kagan
- T24-3A** Engagement and disengagement of recurrent microcircuits in functional and dysfunctional states of the human amygdala
Johanna Derix, Ioannis Vlachos, Martin Herpers, Isabella Mutschler, Moritz Helias, Andreas Schulze-Bonhage, Ad Aertsen, Martin Peper, Arvind Kumar, Tonio Ball
- T24-4A** Selective visual attention in *Drosophila*: How long is the attention-span?
Sebastian Koenig, Preeti Sareen, Reinhard Wolf, Martin Heisenberg
- T24-5A** Feature-based Attentional Modulation in the Primary Visual Cortex of Rhesus Monkeys
Rui-Feng Liu, Valeska Stephen, Stefan Treue
- T24-6A** The influence of body posture on spatial perception: effects of egocentric midline shift
Kerstin Paschke, Igor Kagan, Mathias Bähr, Melanie Wilke
- T24-7A** Connecting Brain and Mind with Formal Concept Analysis: a Data-Driven Investigation of the Semantic, Explicit Coding Hypothesis
Dominik M Endres, Ruth Adam, Uta Noppeney, Martin A Giese
- T24-8A** The endocannabinoid system and its influence on cognition in the zebrafish (*Danio rerio*)
Nicole Prinz, Tim Ruhl, Gerhard von der Emde
- T24-9A** Using haloperidol and levodopa to mimic effects of increased action of dopamine at D1 receptors in humans
Carola Wormuth, Peter van Ruitenbeek, Mitul A. Mehta
- T24-10A** Effects of spatial attention on multi-unit activity in the primary visual cortex of the rhesus monkey
Valeska Marija Stephan, Rui-Feng Liu, Stefan Treue
- T24-11A** Stimulus-unspecific spatial and stimulus-specific feature-based attentional modulations in area MSTd of macaque visual cortex
Sonia Baloni, Daniel Kaping, Stefan Treue

- T24-12A Retracted
- T24-1B** An Attentional Blink with Motion Stimuli
Janina Hueer, Sonia Baloni, Nils Müller, Stefan Treue
- T24-2B** Numerosity discrimination in the carrion crow (*Corvus corone*)
Almut Hoffmann, Andreas Nieder
- T24-3B** Mapping the Regulation of Behavioral Motivation in the Brain of *Drosophila melanogaster*
Ariane-Saskia Ries, Roland Strauss
- T24-4B** The long and the short of it: Carrion Crows learn to flexibly choose stimuli based on relative size
Felix Moll, Andreas Nieder
- T24-5B** Neural Correlates Underlying the Use of Prior Information in Perceptual Closure
Alla Brodski, Georg-Friedrich Paasch, Saskia Helbling, Michael Wibral
- T24-6B** Two functional systems for size perception revealed through different behavioural tasks
Torsten Stemmler, Jan Skorupa
- T24-7B** Effects of graded spatial attention on human direction discrimination thresholds and their dependence on noise
Vera Katharina Marks, Stefan Treue
- T24-8B** Depth of processing in human place recognition
Stephan Lancier, Sabrina Hansmann-Roth, Marc Halfmann, Hanspeter Mallot
- T24-9B** The Influence of Exogenous Sex Hormones on Human Attention and Cognition: An ERP-Study
Nora Lessing, Kristian Folta-Schoofs
- T24-10B** A Modality dependent effect in the Corsi tapping task
Andrea Röser, Gregor Hardiess, Hanspeter A. Mallot
- T24-1C** Ego-motion from Optic Flow: Evidence for a Matched Filter Mechanism
Hanspeter A. Mallot, Till Becker, Fabian Recktenwald, Gregor Hardiess
- T24-2C** Imagery of a Familiar Place Varies with Interview Location
Wolfgang G. Röhrich, Niklas Binder, Hanspeter A. Mallot
- T24-3C** Social defeat in crickets: influences of dopaminergic modulation on the suppression of aggression and its recovery
Paul Anthony Stevenson, Jan Rillich
- T24-4C** Winners and losers - products of nature or nurture? Evidence for potentially inherent differences in aggression between crickets.
Jacqueline Rose, Darron Cullen, Jan Rillich, Stephen Simpson, Paul Stevenson

- T24-5C** Relief conditioning in rats: Role of the amygdala and the Nucleus accumbens
Markus Fendt
- T24-6C** Perceptual Changes and Emotional Impact of Sensory Augmentation
Sabine Ursula König, Jessika Schwandt, Kai Kaspar, Peter König
- T24-7C** Stimulus salience enhancement at the expense of accurate representation: MT responses to transient direction changes and their attentional enhancement
Vahid Mehrpour, Julio C. Martinez-Trujillo, Stefan Treue
- T24-8C** Probing numerosity-selectivity in neurons of the association cortex of numerically-naïve monkeys
Pooja Viswanathan, Andreas Nieder
- T24-9C** Context-dependent coding flexibility of numerosity-selective neurons in the primate prefrontal cortex.
Maria Moskaleva, Andreas Nieder
- T24-10C** Prefrontal neurons encode volitional initiation of monkey vocalizations
Steffen R Hage, Andreas Nieder
- T24-1D** The role of dopamine in risk-based decision making in rats
Bettina Mai, Wolfgang Hauber
- T24-2D** Acute stressor effects on goal-directed action in rats
Wolfgang Hauber, Stephanie Braun
- T24-3D** Prefrontal cortex neurons represent abstract rules applied to multiple magnitudes
Anne-Kathrin Eiselt, Andreas Nieder
- T24-4D** Effect of intense physical activity on Individual alpha frequency (IAF) and Fatigue index (FI).
Irina S. Polikanova, Aleksander G. Tonevitsky
- T24-5D** Iontophoretic stimulation of dopamine D1 receptor enhances numerical rule coding in the primate prefrontal cortex
Torben Ott, Simon N Jacob, Andreas Nieder
- T24-6D** Neural correlates of abstract task-switching in carrion crows
Lena Veit, Andreas Nieder
- T24-7D** Saliva estradiol level predicts individual alpha frequency in women
Christina Brötzner, Wolfgang Klimesch, Michael Doppelmayr, Hubert H. Kerschbaum
- T24-8D** Laughing rats are optimistic
Rafal Rygula, Helena Pluta, Piotr Popik
- T24-9D** Rhesus monkeys can switch volitionally between distinct call types

Natalja Gavrilov, Steffen R. Hage, Andreas Nieder

T24-10D Acquisition vs. Memorization Trade-offs in Comparative Visual Search
Gregor Hardiess, Noemi D Martin, Aylin Sarikaya, Hanspeter A Mallot

T24-11D Visual Search in Barn Owls
Julius Orłowski, Petra Nikolay, Ohad Ben-Shahar, Hermann Wagner

An Internal Representation of Zero Yaw Torque in *Drosophila melanogaster*

Franziska Toepfer, Martin Heisenberg¹, Reinhard Wolf¹

¹Rudolf-Virchow-Zentrum Würzburg, AG Heisenberg, Josef-Schneider-Str. 2, 97080 Würzburg, Germany

Can a fly (*Drosophila*) fly straight without visual cues? Tethered flies are tested at a yaw torque meter. Without any visual cues flies modulate their yaw torque clockwise and counterclockwise over a wide range. Averaged over many flies yaw torque is about normally distributed, while individual flies have their idiosyncrasies.

Here we test them in the flight simulator mode (closed loop) in which the fly's yaw torque drives the angular velocity of two vertical black bars in a circular arena surrounding the fly. In addition to depending upon the fly's yaw torque the two bars are made to move with a constant angular velocity of 40°/s relative to each other (rotatory bias). The fly can stabilize one or the other bar. Interestingly, the fly's behavior depends upon which of the bars carries the rotatory bias. It prefers to stabilize the bar for which its yaw torque is in the range of the mean torque of the normal torque distribution obtained without visual patterns. It is concluded that *Drosophila* possesses an internal representation of zero torque, which would allow the fly to fly straight even without visual cues.

Risk-seeking behavior in monkeys is modulated by effort in a spatial decision task

Adán Ulises Domínguez Vargas, Annika Grass², Stefan Treue³, Melanie Wilke⁴, Igor Kagan¹

¹Decision and Awareness Group, Cognitive Neuroscience Laboratory, German Primate Center, Goettingen, Germany.

²International Max Planck Research School, Goettingen, Germany.

³Cognitive Neuroscience Laboratory, German Primate Center, Goettingen, Germany.

⁴Department of Cognitive Neurology, Universitaet Medizin Goettingen, Goettingen, Germany.

Decision making is a process that involves weighing the costs and benefits of selecting an action among several options. This selection is dependent on how much one has to work in order to achieve a goal, i.e. effort; and how good the outcome might be, i.e. reward expectation. Additionally, motivations and subjective attitudes of each individual play an important role in the decision process. For instance, one factor that can shape action selection is the attitude towards uncertain or risky outcomes. It has been shown that monkeys exhibit risk-seeking behavior (preference for a risky gamble over a certain option) when they make choices with low-effort eye movements. However, it is not known whether the same tendency will be observed when choice requires more demanding, higher effort actions such as arm reaching.

In the present study we designed a task in which monkeys made a decision to reach to one of two targets on a touchscreen, using their right arm. Each target pair consisted of a left and a right target, equidistant to the middle of the screen but located at different spatial positions on the horizontal axis in each trial. When both targets were rewarded equally, monkeys nearly always selected low effort targets, i.e. right targets located closer to the right hand.

Next, we introduced the concept of reward modulation by associating color rings surrounding the targets with different reward amounts. After monkeys learned the color-reward associations, we presented them with a “certain” value-based choice task in which they decided between high and low reward targets. Monkeys were willing to spend more effort in order to obtain higher rewards, overcoming their natural preference for low effort targets. Varying the reward ratio between low and high reward targets served to establish choice functions for different effort levels and to determine the reward ratio needed to counterbalance monkeys' effort preferences.

Finally we presented the monkeys with a “gambling” task, in which they had a choice between a certain reward option and a risky gamble. The gamble target, when selected, randomly yielded one of the two outcomes – “win” with reward higher than the certain option, and “lose” with reward lower than the certain option – with the 50% chance. The overall expected value of the gamble target could be better, equal or worse than the expected value of the certain target.

We found that, similarly to eye movements tasks, monkeys showed a risk-seeking behavior in the reaching task, preferring a risky gamble over a certain option even when the expected value of the certain option was better. However, monkeys exhibited effort-based modulation of their risk-seeking behavior: they were much more willing to gamble for the low effort actions as compared to high effort actions. The difference between gambling preferences for the low and the high effort actions was stronger than predicted by the reward ratio – effort choice functions obtained in the certain reward task, implying a complex relationship between value, effort and risk preferences in the subjective evaluation of

response options. These results suggest that the high effort diminishes risk-seeking behavior.

Engagement and disengagement of recurrent microcircuits in functional and dysfunctional states of the human amygdala

Johanna Derix, Ioannis Vlachos^{1,3}, Martin Herpers⁴, Isabella Mutschler⁵, Moritz Helias⁶, Andreas Schulze-Bonhage^{2,3}, Ad Aertsen^{1,3}, Martin Peper⁷, Arvind Kumar^{1,3}, Tonio Ball^{2,3}

¹Faculty of Biology, University of Freiburg, Freiburg, Germany

²Epilepsy Center, University Hospital, Albert-Ludwig University, Freiburg, Germany

³Bernstein Center Freiburg (BCF), Freiburg, Germany

⁴Department of Neurology, University Hospital, Albert-Ludwig University, Freiburg, Germany

⁵University of California, San Diego, USA

⁶Institute of Neuroscience and Medicine, Computational and Systems Neuroscience (INM 6), Forschungszentrum Jülich, Germany

⁷Faculty of Psychology, Philipps University, Marburg, Germany

Identification of the neural mechanisms that cause neurological and psychiatric pathologies is a major challenge for human brain research, and the amygdala is a neural structure that is associated with a number of affective disorders. Currently, however, little is known about the neural population dynamics of functional and dysfunctional processing in this limbic structure.

Here, we investigated how amygdalar anatomical changes in temporal lobe epilepsy (TLE) affect neural dynamics relative to the unimpaired amygdala. To this end, we employed a new approach that combines the analysis of intracranially-recorded data with a realistic network model of the amygdala. We used an emotional learning experiment in two groups of patients with (23 electrodes) and without (13 electrodes) epileptic changes in the amygdala region, and evaluated the amygdalar local field potentials (LFPs) recorded during the task. Since fast gamma rhythms have been attributed a particularly important role in neural coding, we specifically focused on the high gamma band (HGB) between 70 and 120 Hz of the LFP.

We identified a characteristic spectral response of the amygdalar LFP that involved a pronounced power increase in HGB frequencies. The spectral amplitude of these fast oscillations changed over time in a way that indicated a role of them in emotional learning, both with respect to habituation and conditioning. Our simulations suggest that amygdalar HGB oscillations are generated by recurrent activity in local networks of the amygdala, and that several aspects of affective learning, and possibly other affective functions, are implemented in this network.

The experimentally-observed amygdalar response profiles were differentially affected by TLE in several frequency components. In the HGB, there was a pronounced loss of spectral power relative to HGB responses in the unimpaired amygdala. Results from our modeling suggest that the observed changes in spectral properties of the LFP may have been caused by alterations of the local network parameters due to structural damage to amygdalar tissue and its compensatory network mechanisms. Our findings imply that impairments in emotional learning, often associated with TLE, may be elicited by disturbance of amygdalar HGB activity.

The joint consideration of spectral profiling of neural dynamics, network models, and anatomical data

from the human amygdala provides a novel way of studying the micro-circuit level dynamics and their disorders in this structure.

Selective visual attention in *Drosophila*: How long is the attention-span?

Sebastian Koenig, Preeti Sareen², Reinhard Wolf¹, Martin Heisenberg¹

¹Rudolf-Virchow-Center, University of Wuerzburg, Josef-Schneider-Str. 2, 97080 Wuerzburg, Germany

²Department of Psychology I, University of Wuerzburg, Marcusstr. 9-11, 97070 Wuerzburg, Germany

Higher organisms with complex visual systems often restrict their responses to temporarily selected areas of the visual field. This visual selective attention (VSA) can either be externally guided or endogenously controlled (covert). Here we investigate covert VSA in flying *Drosophila* tethered to a torque-meter. Simultaneous front to back displacement of two black stripes at + and -45° in the fronto-lateral visual field elicits a torque response (i.e. the fly tries to follow the direction of movement of one of the stripes). The direction of the response can either be clockwise or counter-clockwise. Alternatively, the fly may generate no phasic torque response at all. Assuming that the fly responds to only one of the stripes because it has directed its focus of attention (FoA) to that side we can investigate the dynamics of the endogenous shifts of the FoA. We record responses to sequences of consecutive displacements to determine the mean response (and no-response) frequencies. A simulation fed with these data produces continuous chains of responses to the same side with certain length-dependent frequencies. However, flies produce less short and more long chains than expected. We can simulate the higher frequencies of longer chains assuming that the FoA remains oriented into the same direction for longer than the inter-trial interval (ITI).

Feature-based Attentional Modulation in the Primary Visual Cortex of Rhesus Monkeys

Rui-Feng Liu, Valeska Stephen^{1,2}, Stefan Treue^{1,2}

¹Cognitive neuroscience Laboratory, German Primate Center, Kellnerweg 4, 37077 Göttingen, Germany

²Bernstein Center for Computational Neuroscience, Göttingen, Germany

Visual attention can be directed towards a particular location in the visual field, but it can also be allocated to a feature, such as a particular color or a particular direction of motion of a visual stimulus. This kind of attention is called feature-based attention. It has been investigated primarily in middle- and high-level areas of the primate visual cortex, such as MT, V4, LIP, and FEF. Enhancement of neuronal activation by feature-based attention has also been observed in EEG or fMRI studies of V1, the first stage of the visual hierarchy system in the primate cortex, when the subjects attended to the color of visual stimulus (Müller et al., PNAS, 2006; Liu et al., Neuron, 2007; Zhang & Luck, Nature Neurosci., 2009).

Here, we recorded multi-unit activity using an array of 96 electrodes implanted on the surface of area V1 of one rhesus monkey, trained to attend to one of two coherently moving random dot patterns. One of the stimuli was placed to overlap the majority of the receptive fields of the recording sites. The other stimulus appeared on the opposite side of the fixation point. Two experimental conditions were analyzed: 1) attending to motion of the stimulus away from the receptive fields 2) and attending to the fixation point. 12 motion directions were tested, and directional tuning curves of neurons in the two conditions were plotted and analyzed.

We compared the directional tuning curves in the two attentional conditions and found that feature-based attention on average increased the neuronal response when the animal was attending the stimulus moving in the preferred direction by approx. 3% and decreased the neuronal response when the attended stimulus was moving in the anti-preferred direction by approx. 8% without narrowing the tuning curves. This is in line with the predictions of the feature-similarity gain model that posits that the neuronal responses are modulated by attention as a function of the similarity of the attended feature and the preferred feature of the recorded neuron.

Our results indicate that feature-based attention modulates neuronal responses in primate area V1. The feature-based attention modulation pattern agrees with the predictions of the feature-similarity gain model.

The influence of body posture on spatial perception: effects of egocentric midline shift

Kerstin Paschke, Igor Kagan², Mathias Bähr³, Melanie Wilke^{1,2}

¹Department of Cognitive Neurology, University of Göttingen, 37075 Göttingen, Germany

²German Primate Center, Leibniz Institute for Primate Research, 37077 Göttingen, Germany

³Department of Neurology, University of Göttingen, 37075 Göttingen, Germany

The ability to detect and to act on relevant visual information in a rich environment is critical for survival. Following brain lesions in humans and non-human primates, this ability is disturbed in spatial neglect - a frequent neuropsychological disorder (Wilke et al., 2012). Neglect is characterized by an insufficient exploration of the contralesional space by means of head and eye movements. According to the transformation theory, the origin of symptoms can be explained by a failure of transforming multisensory inputs into motor commands within different reference frames and a subjective shift of the body midline towards the ipsilesional space (Karnath et al., 1991; Vossel et al., 2010). Respectively, changes in patients' body posture can lead to a transient reduction of neglect symptoms (Karnath, 1994). However, until today, little is known about the physiological contribution of multisensory transformations to spatial performance.

In order to close this gap, we investigated the influence of body posture on spatial perception in healthy human subjects (16 right and 13 left handed). The subjects were sitting in front of a computer monitor with a rotation around their longitudinal trunk axis to 0, -60, or +60° while the head and initial eye position were fixed. In the context of a stimulus onset asynchrony (SOA) task, subjects were instructed to make a saccade towards the first of two targets presented in opposite hemifields. Targets appeared either simultaneously or with a temporal delay (33, 67, or 267 ms). Eye movements were recorded during the entire session.

As the main result, a 5-factorial ANOVA of the percentage of correct and free choice responses with the factors body rotation, SOA, saccade direction, handedness, and eye dominance for each hemifield revealed a significant interaction effect of the factors body rotation and saccade direction ($F(2, 52)=3.308$, $p<0.05$). Specifically, body rotation led to a relative increase of ipsilateral correct SOA detection. Furthermore, a 5-factorial ANOVA of saccade latency showed a trend for the same interaction ($F(2, 52)=2.378$, $p=0.1$) suggesting a possible ipsilateral facilitation of oculomotor execution.

In conclusion, our experiment shows that body rotation has an influence on spatial perception and affects detection and response times. This might be due to an induced shift of the egocentric midline in the direction of the body rotation. Future experiments have to elucidate whether these effects are based on pure perceptual, attentional or motor response facilitation processes (or a combination) and what the underlying neural substrates are.

References:

- Karnath, H.O. (1994). Subjective body orientation in neglect and the interactive contribution of neck muscle proprioception and vestibular stimulation. *Brain* 117 (Pt 5), 1001-1012.
- Karnath, H.O., Schenkel, P., Fischer, B. (1991). Trunk orientation as the determining factor of the 'contralateral' deficit in the neglect syndrome and as the physical anchor of the internal representation of body orientation in space. *Brain* 114 (Pt 4), 1997-2014.
- Vossel, S., Kukulja, J., Fink, G.R. (2010). Neurobiology of neglect: implications for new therapeutic strategies. *Fortschritte der Neurologie-Psychiatrie* 78, 733-745.
- Wilke, M., Kagan, I., Andersen, R.A. (2012). Functional imaging reveals rapid reorganization of cortical activity after parietal inactivation in monkeys. *Proc Natl Acad Sci U S A* 109, 8274-8279.

Connecting Brain and Mind with Formal Concept Analysis: a Data-Driven Investigation of the Semantic, Explicit Coding Hypothesis

Dominik M Endres, Ruth Adam², Uta Noppeney², Martin A Giese¹

¹CIN, HIH, BCCN, University Clinic of Tübingen, Section Computational Sensomotrics, Dept. Cogn. Neurology, Otfried-Müller Str. 25, 72076 Tübingen, Germany

²Cognitive Neuroimaging Groups, Max Planck Institute for Biological Cybernetics, Spemannstr. 41, 72012, Tübingen, Germany.

Understanding how semantic information is represented in the brain has been an important research focus of neuroscience in the past few years. Unlike 'traditional' neural (de)coding approaches, which study the relationship between stimulus and neural response, we are interested in higher-order relational coding: we ask how perceived relationships between stimuli (e.g. similarity) are connected to corresponding relationships in the neural activity. Our approach addresses the semantical problem, i.e. how terms (here stimuli) come to have their (possibly subjective) meaning, from the perspective of the network theory of semantics (Churchland 1984). This theory posits that meaning arises from the network of concepts within which a given term is embedded.

We showed previously (Endres et al 2010, AMAI) that Formal Concept Analysis (FCA, (Ganter & Wille 1999)) can reveal interpretable semantic information (e.g. specialization hierarchies, or feature-based representation) from electrophysiological data. Unlike other analysis methods (e.g. hierarchical clustering), FCA does not impose inappropriate structure on the data. FCA is a mathematical formulation of the explicit coding hypothesis (Foldiak, 2009, Curr. Biol.)

Here, we investigate whether similar findings can be obtained from fMRI BOLD responses recorded from human subjects. While the BOLD response provides only an indirect measure of neural activity on a much coarser spatio-temporal scale than electrophysiological recordings, it has the advantage that it can be recorded from humans, which can be questioned about their perceptions during the experiment, thereby obviating the need of interpreting animal behavioural responses. Furthermore, the BOLD signal can be recorded from the whole brain simultaneously.

In our experiment, a single human subject was scanned while viewing 72 grayscale pictures of animate and inanimate objects in a target detection task (Siemens Trio 3T scanner, GE-EPI, TE=40ms, 38 axial slices, TR=3.08s, 48 sessions, amounting to a total of 10,176 volume images). These pictures comprise the formal objects for FCA. We computed formal attributes by learning a hierarchical Bayesian classifier, which maps BOLD responses onto binary features, and these features onto object labels. The connectivity matrix between the binary features and the object labels can then serve as the formal context.

In line with previous reports, FCA revealed a clear dissociation between animate and inanimate objects in a high-level visual area (inferior temporal cortex, IT), with the inanimate category including plants. The inanimate category was subdivided into plants and non-plants when we increased the number of attributes extracted from the fMRI responses. FCA also highlighted organizational differences between the IT and the primary visual cortex, V1. We show that subjective familiarity and similarity ratings are strongly correlated with the attribute structure computed from the fMRI signal (Endres et al. 2012, ICFA).

Acknowledgements: this work was supported by: BMBF FKZ: 01GQ1002, EC FP7-ICT grants TANGO 249858, AMARSi 248311, DFG GI 305/4-1, DFG GZ: KA 1258/15-1 and the Max-Planck Society.

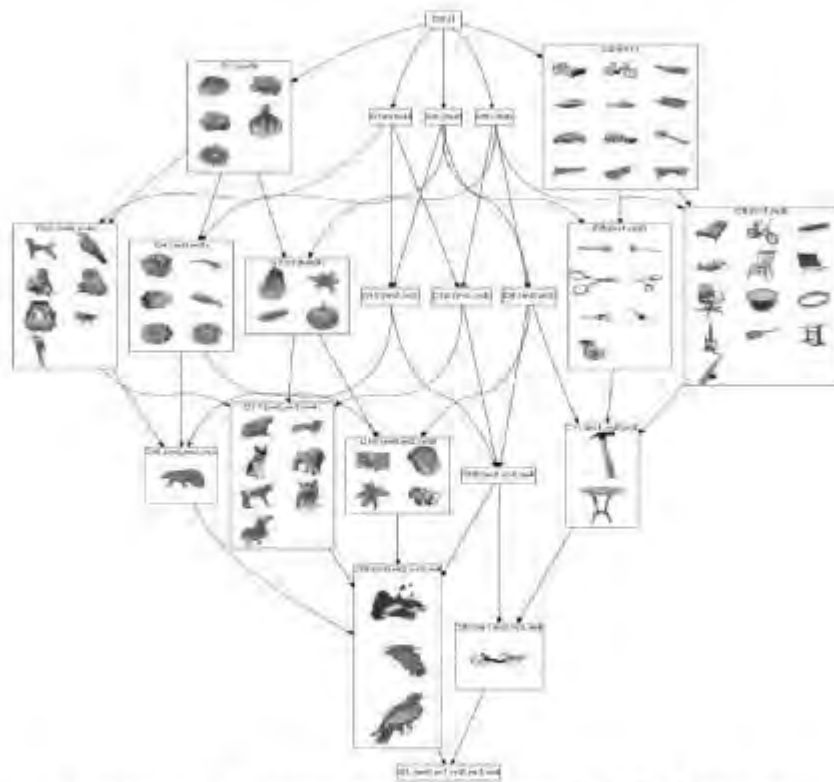

Concept lattice computed from human IT BOLD signals. Left : living things, with plants on top and animals at the bottom. Right half: Inanimate objects.

The endocannabinoid system and its influence on cognition in the zebrafish (*Danio rerio*)

Nicole Prinz, Tim Ruhl¹, Gerhard von der Emde¹

¹University of Bonn, Institute of Zoology - Department of Neuroethology, Endenicher Allee 11 - 13, 53115 Bonn, Germany

The endocannabinoid system (ECS) is thought to be highly conserved among vertebrate species. Neurocytochemical findings have indicated that the cannabinoid receptor 1 (CB1) is distributed in brain centers that were defined to be involved in similar cognitive mechanisms in mammals and in fish. Lesion experiments with goldfish (*Carassius auratus*) indicate that memory of emotional-associative learning is stored in the medial pallium (MP), and that spatial information is stored in the lateral pallium (LP) of the teleost dorsal telencephalon. These areas are marked by a high density of CB1 in the zebrafish. Many studies in mice and rats reported that both acute and chronic exposure to CB1 agonists disrupt cognitive functions, including spatial cognition, working memory and attentional or emotional processes.

In different behavioral approaches we investigated the influence of acute and chronic ECS-activation/-inactivation by use of a receptor agonist (THC: delta9-tetrahydrocannabinol) and an antagonist (Rimonabant), respectively. (A) A two-alternative choice paradigm for color-discrimination was used to assess the emotional-associative memory. (B) In an open-field maze we tested spatial cognition in zebrafish. Finally, (C) anxiety-like behavior of the animals was investigated with a test involving an escape response.

We could show that acute pharmacological treatment with CB1 agonist selectively impaired behavioral performance of zebrafish in the open-field maze, but not in the visual discrimination task. Chronic administration of CB1 antagonist slightly enhanced learning in color-discrimination, but significantly improved reversal learning when compared with untreated controls. In summary, our data indicate that not only neurochemical anatomy, but also psycho-physiological working mechanisms of the ECS are highly conserved among vertebrate species. The zebrafish, because of its rich cognitive capabilities and its strong genetic background, is another powerful model organism for investigation of the vertebrate ECS.

Using haloperidol and levodopa to mimic effects of increased action of dopamine at D1 receptors in humans

Carola Wormuth, Peter van Ruitenbeek^{2,3}, Mitul A. Mehta³

¹Federal Institute for Drugs and Medical Devices, Cellular and Systemic Neurophysiology, Kurt-Georg-Kiesinger-Allee, 53175 Bonn, Germany

²King's College London, Institut of Psychiatry, Centre for Neuroimaging Sciences, De Crespigny Park, London SE5 8AF, UK

³Katholic University Leuven, Dept. of Biomedical Kinesiology, Tervuursevest 101, BE-3001 Heverlee, Belgium

Schizophrenia is a highly debilitating disorder. Symptoms like hallucinations and delusions in combination with decreased cognitive capacity reduce daily life quality. While current medicinal treatments are aimed at reducing hallucinations and delusions, the cognitive deficits remain largely untreated. An altered dopamine system in the prefrontal cortex (PFC) may underlie the cognitive deficits since both the number of D1 receptors and release and synthesis of dopamine in the PFC are affected in schizophrenics. In addition, depletion of dopamine in the frontal cortex leads to cognitive impairments resembling those observed in schizophrenia. The D1 receptor is highly distributed in the PFC and is considered to be important for cognitive stability and memory function. Optimal D1 receptor activation is thought to lead to a state of focused attention and efficient utilization of the dopamine in the PFC, whereby memory performance is optimised. In contrast, the D2 receptor is less abundant and thought to influence cognitive flexibility. Cognitive flexibility is important for constantly updating and integrating new information.

To evaluate whether increased dopamine D1 action in the PFC leads to improved cognitive performance, this study administered levodopa/carbidopa (100/25mg) and haloperidol (2mg) to fourteen male, right-handed healthy volunteers (mean age 25.3 ± 4.9) in a 2-way double blind, placebo controlled cross-over design. Levodopa/carbidopa increases free dopamine levels, while subsequent excessive D2 activation is prevented by haloperidol administration. Working memory performance and associated brain activity was assessed using the N-back task while volunteers were scanned using a magnetic resonance imaging (MRI) scanner. Performance on the N-back task requires cognitive stability to store and retrieve information, but also flexibility to update working memory content.

Accuracy in both the placebo and the drug condition decreased slightly with the level of difficulty. Drug decreased the reaction time in the more complicated N-back conditions, albeit not significantly. Brain areas involved in working memory processing were slightly more activated during the N-back task in the drug condition compared to the placebo condition. In contrast, activation in areas comprising the default mode network (DMN) was decreased during the drug condition. However, all these changes were not significant.

Although the drug seems to positively influence working memory processing by increasing its networks activity, performance of the participants did not significantly improve. Yet, there is a tendency for a faster visual and motor reaction.

Deactivation of the DMN during working memory tasks indicates a redistribution of resources towards brain areas needed to perform the task efficiently. The drug seems to facilitate this reorganization. One could speculate that an increased activation of the working memory processing network paired with a decreased default mode network leads to a more efficient processing of the information and thus facilitates goal-directed actions within the brain, although this study could not prove this significantly, but can only give a hint into this direction.

Effects of spatial attention on multi-unit activity in the primary visual cortex of the rhesus monkey

Valeska Marija Stephan, Rui-Feng Liu¹, Stefan Treue^{1,2}

¹German Primate Center, Cognitive Neuroscience Laboratory, Kellnerweg 4, 37077 Göttingen, Germany

²Bernstein Center for Computational Neuroscience, Am Fassberg 17, 37077 Göttingen, Germany

In area MT in the visual cortex of awake, behaving rhesus monkeys a spatial shift of the focus of attention between two locations within a given receptive field results in a shift of the receptive field's center towards the location of the new focus (Womelsdorf, 2006). While the mechanism underlying this effect is unknown, McAdams & Maunsell (1999) hypothesized that it could originate in lower visual areas (such as primary visual cortex, V1). Here, because of the much smaller receptive field sizes, the two alternate locations are represented by distinct neuronal populations, rather than falling within the same receptive fields. Because the two pools of neurons differ in the behavioral relevance of the respective stimulus they encode, attentional influences might cause a differential modulation of their firing rates.

Combining these two inputs to form the larger receptive fields of area MT neurons would cause a receptive field shift.

To test this hypothesis we measured attentional effects in V1 neurons under the specific attentional conditions that cause receptive field shifts in area MT.

We recorded multi-unit extracellular activity from one rhesus monkey with a 96-channel Utah Array implanted into V1. While recording, two random dot stimuli moving within stationary apertures were presented to the animal. One was placed inside the receptive fields, the other outside at same eccentricity in the same hemifield. In a given trial the monkey was cued to attend to one of the stimuli. While keeping the fixation on a fixationpoint, the animal had to give a speeded response to a direction change in the target stimulus. Eye positions were closely monitored with a video eye tracker throughout the experiments. Fixation radius was limited to 1 degree around the fixationpoint.

We compared the neuronal responses for the two different attentional conditions for recording sites which showed a significant sensory response. A significant response was defined as a doubling of neuronal response for the sensory condition compared to a baseline condition in which only a fixation point was presented on the screen. We found a small but significant increase of the response when the monkey was attending inside the receptive field as to outside the receptive field. This is in line with the hypothesis that spatially specific attentional modulation in V1 contributes to the attentional modulation of receptive field profiles observed in MT.

Stimulus-unspecific spatial and stimulus-specific feature-based attentional modulations in area MSTd of macaque visual cortex

Sonia Baloni, Daniel Kaping³, Stefan Treue^{1,2}

¹German Primate Center, Cognitive Neuroscience Laboratory, Kellnerweg 4, 37077 Goettingen, Germany

²Bernstein Center for Computational Neuroscience, Goettingen, Germany

³Department of Biology, York University, Toronto, Canada

Visual information processing in extrastriate visual cortex in primates is accomplished along two major pathways, the dorsal pathway involved in motion processing and the ventral pathway involved in object identification. Area MST belongs to the dorsal pathway. Neurons in the dorsal part of MST (MSTd) are characterized by large receptive field and their tuning for the direction of spiral motion stimuli. A subpopulation of MSTd neurons also shows tuning to linear motion stimuli. We determined how MSTd responses to the two stimulus types are modulated by spatial and feature-based attention. In addition we wondered if these attentional effects provide evidence for the contribution of MSTd neurons to the perception of the two stimulus types.

Extracellular activities of single MSTd cells were recorded from two awake behaving macaque monkeys engaged in a spatial or a feature-based attention task. We observed spatial attentional modulations for both spiral and linear motion. The average spatial attentional modulation for both stimulus types was around 30%. But feature-based attentional modulation was found only for spiral and not for linear motion, in spite of the presence of tuning for both stimulus types. We then correlated firing rates under different attentional conditions with the reaction times for linear and spiral motion stimuli. We found modest but significant negative correlations of the firing rates with the reaction times when attention was directed to the preferred spiral motion direction, but not when the preferred linear motion was attended.

Our results demonstrate that spatial attention modulations are independent of the attended stimuli and therefore observed in area MSTd for both spiral and linear motion. On the other hand, feature-based attention does not modulate responses of a neurons to all the stimulus types a neuron is tuned for. This is apparent in the absence of feature-based attention modulation for linear motion despite MSTd's tuning for this motion type. The presence of negative correlations of the firing rate with the reaction times for spiral but not for linear motion indicates that despite their tuning MSTd neurons might not contribute to the perception of linear motion.

The project was supported by a grant (01GQ0433) of the German Federal Ministry of Education and Research to the Bernstein Center for Computational Neuroscience, Goettingen.

An Attentional Blink with Motion Stimuli

Janina Hueer, Sonia Baloni^{1,2,*}, Nils Müller³, Stefan Treue^{1,2}

¹German Primate Center, Cognitive Neuroscience Laboratory, Göttingen, Germany

²Bernstein Center for Computational Neuroscience, Göttingen, Germany

³Donders Institute for Brain, Cognition and Behaviour, Radboud University Nijmegen, The Netherlands

*These authors contributed equally to this work

We have the ability to voluntarily attend to specific sensory information in our environment. This ability allows us to behave in a goal-oriented and flexible manner. However, it continuously restricts our perception to a small fraction of the available information. This limitation of processing is unveiled by a phenomenon called the Attentional Blink. In typical Attentional Blink experiments subjects have to detect a visual target stimulus (T1) embedded in a sequence of rapidly presented distractor stimuli and report a specific feature of that stimulus. The processing triggered by this task usually results in a reduced ability to see a second target stimulus (T2) when it is presented about 100-400ms after T1. This temporary impairment in processing T2 has been called Attentional Blink. In the majority of Attentional Blink studies T1 and T2 were stationary visual stimuli. Given the two cortical processing streams for form and motion, we asked whether attending to moving visual stimuli also creates an Attentional Blink. Therefore, we conducted two experiments using (a) moving random dot patterns and (b) a combination of moving random dot patterns and stationary letter stimuli. In both experiments, we instructed subjects to report the direction of a target random dot pattern (T1). This resulted in a reduced ability to perceive a subsequent shown T2 that was either (a) a moving or (b) a stationary target stimulus. The impairment lasted for about 300ms, which was equal to the duration found in a control experiment using only stationary stimuli. The maximal impairment occurred around 250ms after T1, and subjects usually missed T2 at that point in time in more than one third of trials. Our results show that attending to a movement can result in an Attentional Blink. This indicates that the Attentional Blink is a global attentional effect impairing different processing streams of the visual system in the same way.

Numerosity discrimination in the carrion crow (*Corvus corone*)

Almut Hoffmann, Andreas Nieder¹

¹Uni Tübingen, Animal Physiology, Institute of Neurobiology, Auf der Morgenstelle 28, 72076 Tübingen, Germany

In his classical work from the middle of the last century, Otto Koehler provided for the first time scientific evidence that corvid birds are endowed with superior skills in categorizing and conceptualizing numerical quantity. Currently, the prevailing opinion is that numerosity discrimination is based on an analog magnitude system obeying Weber's law. Weber's Law states that the discriminability of two numerosities is proportional to their ratio rather than a function of the absolute difference between them. Here we trained a carrion crow to discriminate the cardinal value of sets of objects to explore whether Weber's Law also holds in corvids.

We examined nonverbal numerical discrimination of visually presented dot patterns in the carrion crow. A crow was trained with a touch sensitive monitor on a delayed match to sample task with quantities ranging from one to eight. In this task protocol, the sample stimulus appeared on the central part of the touch screen. The birds had to peck on the sample numerosity to continue with the delay period. After the delay, the match and the non-match stimulus appeared simultaneously on the touch screen. The match stimulus represented the same number of dots as the sample stimulus, but showed differences in dot sizes and dot arrangements. The non-match numerosity showed either more or less dots than the sample. The birds received reward for pecking on the numerosity set which matched the sample. Numerosities one to eight were tested. To exclude that the crow used non-numerical cues to solve the task, two subsets of stimuli were used: standard stimuli and control stimuli for area and density control. The standard stimuli showed randomly distributed dots of varying diameter. The total area and the mean density of all dot was equated for the area and density control stimuli. All stimuli were generated anew every session using custom-written Matlab software.

Preliminary results based on one crow reflected fundamental psychophysical effects in the behavioral data. With increasing numerical distance between two numerosities, the crow showed increasingly better performance (numerical distance effect). Larger numerosities which differed in the given numerical distance, were harder to differentiate from each other than smaller numbers, which had the same numerical distance (numerical magnitude effect). The behavioral performance curves for respective sample numerosities seem to be better described by a logarithmical than by a linear scale, suggesting that the data obeys Weber's law.

Comparison of these results with data from primates suggests fundamental behavioral similarities. In human and non-human primates, numerosity is represented on an analog, approximate and logarithmically compressed continuum, or scale. The same type of numerical representation seems to be present in corvids. This indicates a similar manner of processing quantity information in the avian and mammalian brain, two differently structured brains with similar functions based on convergent evolution.

Mapping the Regulation of Behavioral Motivation in the Brain of *Drosophila melanogaster*

Ariane-Saskia Ries, Roland Strauss¹

¹Johannes-Gutenberg University, Department of Zoology III - Neurobiology, Colonel-Kleinmann-Weg 2, 55128 Mainz, Germany

Motivation is the central driving force in human and animal nature. Pleasant stimuli like meals and drinks enhance certain behavioral patterns - especially after a period of deprivation -, whereas unpleasant stimuli like inescapable stress and threats can have the opposite effect on behavior. Seligman described this latter phenomenon of progressive inactivity in animal behavior following an exposure to unpredictable and inescapable stress as a state of "learned helplessness" (1967). He claimed this behavioral pattern to be a model for human depression. Subsequently, this depression-like state has been found in many vertebrates and it can be reverted by antidepressant drugs. On the other hand, efforts to achieve a pleasant stimulus can incite physical effort in every living organism to ensure survival and reproduction.

In this study, we first provide evidence for comparable enhanced and depressed behavioral states in *Drosophila melanogaster*. The first step was the development of a new paradigm, in which *Drosophila* can be subjected to inescapable stress in the form of repeated inescapable vibrations at an unpleasant frequency. Following this treatment, the flies displayed a decrease in the willingness to engage in climbing behavior in a gap-climbing paradigm. This effect is reversible by feeding a serotonin precursor known to act as anti-depressant (Bertolucci, PhD thesis). Furthermore, we presented positive motivational stimuli like pleasant visual and olfactory cues on the distal side of the gap to the flies and thereby elicited an increase in their rate of attempts to cross the gap. Next, we started to search for structures in the brain of *Drosophila*, which underlie the control of motivation. With the help of the GAL4/UAS-system (Brand and Perrimon, 1993) we were able to identify the mushroom bodies as a required brain structure for an enhancement of the motivation for climbing behavior induced by pleasant olfactory cues. Flies with blocked chemical synapses of the mushroom bodies showed no motivational enhancement in their climbing attempts, even after a period of food deprivation. We are now trying to obtain a more detailed mapping for the regulation of behavioral motivation in the brain and are searching for a possible connection between the motivation exerted by visual and by olfactory cues.

This work was supported by a PhD stipend to Ariane-Saskia Ries from the Stipendienstiftung Rheinland-Pfalz.

The long and the short of it: Carrion Crows learn to flexibly choose stimuli based on relative size

Felix Moll, Andreas Nieder¹

¹ Universität Tübingen, Animal Physiology, Institute of Neurobiology, Auf der Morgenstelle 28, 72076 Tübingen, Germany

Over the past decade, corvid behavioural studies became revitalized and an impressive bulk of data about the superior cognitive capabilities of these birds has been gathered. A necessary ingredient of intelligent behaviour is the ability for quantity estimation, or formation of generalized magnitude classes. Quantities are abstracted beyond specific details of sensory inputs and can thus be easily generalized and adapted to new circumstances. Processing quantities is based on abstract principles, or rules, of how to structure and evaluate quantitative information, thus inherently requiring cognitive control functioning. However, whether crows can follow rules related to quantities remains elusive. Here, we trained a crow to choose either relatively shorter or longer lines in a rule-switching task.

We trained two carrion crows to perform a rule-cued choice task in a computerized procedure. The crow was placed on a perch in front of a touch-screen within a conditioning chamber. To start a trial, a red or blue square was shown and the crow had to peck the cue to continue. The colored square served as a rule cue and informed the crow whether to pick the longer or shorter of two vertical lines shown simultaneously after a 1 sec delay period. If the crow pecked at the correct line, it received a reward from a feeder. Two different line lengths from a set of up to five different lengths were shown. Control stimuli were used to control for the total area of two line lengths. We presented the different line lengths in a balanced and pseudo-randomized fashion.

A first crow learned to choose the correct relative line length independent of the absolute line lengths by following the longer- or shorter-than rule. The particular visual appearance of the lines, i.e. total area, was irrelevant for the crow's behavior. Preliminary results show a highly significant choice performance. Importantly, the crow immediately generalized the longer-/shorter-than rules to new line lengths after mastering the simplest version of the task employing only two different line lengths.

These preliminary data indicate that crows can follow rules to choose stimuli that are relatively larger or smaller in size than a comparison stimulus. This requires representation of abstract quantity information. Moreover, the crow easily learned to switch between the cued rules, thus exhibiting a remarkable degree of executive flexibility.

Neural Correlates Underlying the Use of Prior Information in Perceptual Closure

Alla Brodski, Georg-Friedrich Paasch¹, Saskia Helbling², Michael Wibral¹

¹Goethe University Frankfurt, MEG Unit, Brain Imaging Center, Heinrich Hoffmann Strasse 10, 60528 Frankfurt/Main, Germany

²Goethe University Frankfurt, Institute of Medical Psychology, Heinrich Hoffmann Strasse 10, 60528 Frankfurt/Main, Germany

According to predictive coding theory, incoming sensory input is constantly matched with predictions based on expectations learned from environmental regularities. Predictive coding theory posits that cortical activity may represent either predictions or prediction error at each stage of the cortical hierarchy. Based on the anatomical connectivity, it can be hypothesized that activity in the gamma frequency range reflects bottom-up propagation of prediction error, whereas activity in the beta (and alpha) frequency range represents top-down propagation of (updated) predictions.

Top-down influences based on prior expectations are of particular importance in perceptual closure tasks, in which object recognition despite of incomplete visual information is required. In the present study we used degraded (two-tone) images of faces (Mooney faces) to examine perceptual closure in a face detection task during MEG recordings.

Faces are usually perceived in upright orientation, moreover illumination from above by a single light source is expected. Both essential priors were independently violated in our study by varying stimulus orientation (upright or inverted) and illumination direction (top or bottom) during stimulus creation.

Psychophysics revealed main effects of orientation and illumination on hit rates as well as reaction times. Orientation and illumination showed a significant interaction on the hit rates, but additive effects on the reaction times.

Time-frequency analysis of MEG activity on beamformer estimates of power on the source level revealed an early (0-200 ms) orientation effect in the high gamma frequency band, illumination effects in an intermediate time interval (150-350 ms) in the high gamma, low gamma and alpha frequency band and interaction effects in an intermediate and late time interval (300-500 ms) in the low gamma and beta frequency band, respectively. These effects were located to brain areas involved in shape processing, but also in spatial memory, selective attention, matching operations and in the analysis of familiar associations. Further, directed interactions in the task relevant network on the source level were reconstructed by transfer entropy and revealed differential patterns depending on which prior was violated or fulfilled in that experimental condition.

We argue that our results can be interpreted in terms of predictive coding theory and propose a model which integrates the predictive coding framework with a well-established model for Mooney face recognition proposed by Cavanagh (1991).

Two functional systems for size perception revealed through different behavioural tasks

Torsten Stemmler, Jan Skorupa¹

¹RWTH Aachen, Institute for Biology 2, Mies van der Rohe Strasse 15, 52074 Aachen, Germany

Object-size perception has been investigated in great detail in different contexts in humans. Early reports indicated that size discrimination of two simultaneously viewed objects do not follow Weber's law. The Just Noticeable Difference (JND) is not a function of reference size. Here we present data, which do not only contradict directly this claim for manual responses, but although data which verify this claim for saccadic responses. These finding may suggest two distinct systems that are recruited in size judgment depending on the answer method.

In three experiments we first measured by a manual 2 AFC-task the just noticeable size difference for five reference squares (45° tilted, ranging in size from 80.62 to 241.78 arcmin) in comparison to test-squares, which differed in size to the reference from -16% to 16% in 2% steps. Participants had to indicate the larger square by pressing a corresponding push button. Squares were presented on a CRT-Monitor (200Hz) for 200 ms and were defined over a luminance of 28.6 cd/m² against a near black background. Squares were 587.4 arcmin horizontally apart (center of mass) and randomly shifted in vertical direction in order to obscure relative height. In a second experiment we controlled the influence of overall luminance difference between test squares and reference squares caused by varying size. Participants compared by a manual 2 AFC task one of five different reference squares (same sizes as in experiment 1) against test squares of same size differing in luminance increment. In a third experiment participants had to perform the same task as in experiment 1, but instead of using manual input devices had to indicate the larger square with a corresponding eye-movement.

In contradiction to earlier reports (Ono 1967, Mathews 1969), size judgment in experiment 1 indeed follows Weber's Law, as it is known for sequential viewed objects. We assume that the difference is due to the induction of a random vertical shift and short presentations times. The influence of luminance can be ruled out, since the JND for luminance between two objects is eight fold higher than the induced luminance difference from varying sizes. We present a Maximum Likelihood Estimate model in order to support our argument. Intriguing is the finding of our last experiment, since saccadic responses do not follow Weber's law, but show a near fixed size offset regardless of reference size.

We attribute the difference between saccades and manual responses to the same stimuli to two separate functional systems. The manual task allows for longer processing times (response latencies of 550 ms) and needs to recruit cognitive function in order to elicit a complex manual movement (i.e. push of a button). Saccadic responses show shorter latencies (200 ms and less), only allowing for a very brief processing time and not necessarily depending on higher cognitive function, as the superior colliculus suffices as major contributor for saccadic execution for reflexive behaviors.

Mathews M.L., 1969: Visual size difference discrimination: Effect of disc size and retinal locus. *Percept. Psychophys.* 6 (3): S. 160-162.

Ono H., 1967: Difference threshold for stimulus length under simultaneous and non-simultaneous viewing conditions. *Percept. Psychophys.* 2: S. 201-207.

Effects of graded spatial attention on human direction discrimination thresholds and their dependence on noise

Vera Katharina Marks, Stefan Treue¹

¹German Primate Center, Cognitive Neuroscience Laboratory, Kellnerweg 4, 37077 Goettingen, Germany

Directing attention to a specific location in the visual field without a corresponding eye movement results in enhanced processing of stimuli presented at that location compared to other, unattended locations. This leads to an improvement in detection and discrimination of the covertly attended stimulus as well as a reduction in reaction times.

There are different ways to guide an observers' spatial attention to a specific location. Salient exogenous cues presented at the relevant location capture automatic attention whereas endogenous cues are typically symbolic, centrally presented and thus guide top-down attention. We investigated the influence of exogenous covert attention on visual motion direction discrimination thresholds in human subjects. Importantly, we manipulated the amount of spatial attention deployed by varying the validity of the cue.

In our paradigm an exogenous cue was used to attract the spatial attention of the observers to one of two random dot patterns (RDP, diameter 5 deg, moving at a speed of 8 deg/s within stationary virtual apertures), centered at 5 degrees eccentricity to the left and right, respectively, of a central fixation point. RDPs were shown for only 75ms, each followed by a mask stimulus of the same duration to terminate information uptake. By using different levels of cue validity, we created four attentional conditions (100%, 75%, 50%, 25%). Well-trained observers performed a 4-alternative forced-choice (4AFC) direction discrimination task. They were asked to report the location (left or right) as well as the motion direction (up or down relative to horizontal) of the stimulus by pressing one of four buttons. Using such a 4AFC discrimination task, true attentional effects can be discriminated from effects of stimulus uncertainty. We used four levels of noise created by varying motion coherence (40%, 60%, 80%, 100%) in the RDP.

Our results show that the validity of the cue affected observers' discrimination thresholds in a graded manner, i.e. 100% attention to one location resulted in highest performance whereas the smallest amount of attention (25%) lead to the weakest performance. Motion coherence also affected performance, with discrimination thresholds increasing with decreasing levels of motion strength. These two effects on performance seem to operate independently, with no interaction found between coherence and level of graded attention.

Depth of processing in human place recognition

Stephan Lancier, Sabrina Hansmann-Roth¹, Marc Halfmann¹, Hanspeter Mallot¹

¹ University of Tübingen, Cognitive Neuroscience, Auf der Morgenstelle 28, 72076 Tübingen, Germany

Background: The recognition of places is a basic element of spatial behaviour and spatial memory combining context from other places (map and route knowledge, O'Keefe & Nadel's 1978 taxon system) with sensory cues available at the target place (local position information, O'Keefe & Nadel's locale system). It can be argued that the latter part, place recognition from current sensory cues, is the more basic one, as it has less memory requirement. What are the sensory cues used in place recognition? In insects, the concept of a snapshot has been developed which is a panoramic view of the environment, as seen from the target position. The snapshot can be raw, i.e. an array of light intensities taken at the receptor level, or processed to various degrees, for example snapshots based on intensity edges (Cartwright & Collett *Nature*, 1983), Gabor features (Sheynikhovich et al., *Psych. Rev.*, 2009), distances to surrounding walls (cf. Barry et al., *Rev. Neurosci.*, 2006), or skyline elevation (e.g., Basten & Mallot, *Biol. Cybern.*, 2010). Humans are able to recognize places from raw snapshots if no other cues are available (Gillner et al., *Cognition*, 2008). In addition to snapshot-like place codes, landmark objects and configurations of landmark objects have been shown to be used in place recognition (e.g., Morris, *Learning and Motivation*, 1981; Hort et al. *PNAS*, 2007). Recently, 'spatial layout' has been suggested as a third type of cognitive place codes (Epstein, *Trends in Cognitive Sciences*, 2008). Purpose: In the present project, we use virtual reality psychophysics to disentangle the different types of information interacting in human place encoding and place recognition. Subjects are asked to navigate to a previously learned place from various starting positions. Approach trajectories as well as the position where recognition occurs (i.e. where a button is hit) are recorded and compared to theoretical predictions. Experiment 1 addresses the idea of depth-based place coding: can the recognition of places be based on depth or distance information alone, even in the absence of other image information such as texture cues, or objects? To test this question, we use dynamic, interactive random dot stereograms of kite-shaped rooms. Results indicate that place recognition can indeed be based on the matching of depth information alone. Experiment 2 addresses the question if the usage of landmark objects can also be explained by a simple snapshot mechanism. In the learning phase the subjects were trained to the crossing point of plus-shaped board-walk over a pond (see figure). In the experimental phase the pond and bridge were covered by ground fog and the subjects had to recognize the crossing point solely via four distinguishable landmark objects standing out from the pond. Snapshot theory predicts that recognition points should be displaced towards the approach direction (e.g., Hübner & Mallot, *Autonomous Robots*, 2007) but that on average, recognition should be veridical. Our results demonstrate the predicted displacement in the approach direction. In addition, we found a systematic bias towards the center of gravity of the landmark configuration, which is not predicted by snapshot theory. We conclude that human place recognition does not rely on snapshot matching alone.

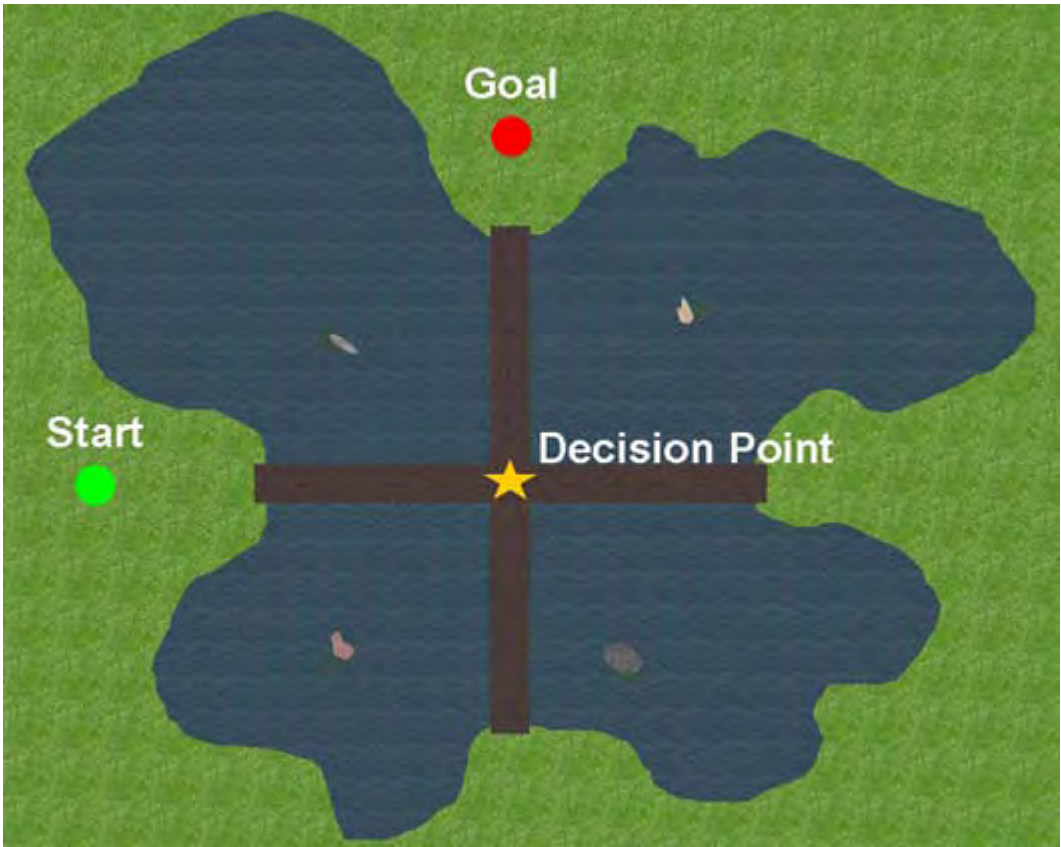

The Influence of Exogenous Sex Hormones on Human Attention and Cognition: An ERP-Study

Nora Lessing, Kristian Folta-Schoofs¹

¹University of Hildesheim, Institute of Psychology, Marienburger Platz 22, 31141 Hildesheim, Germany

The aim of this study was to test the effects of exogenously induced sex hormones on human attention and cognition in human female subjects. To this end, electrophysiological recordings were combined with psychophysical methods. A total of N=19 healthy women on either oral or vaginal monophasic contraception served as subjects. Concentrations of exogenous sex hormones were manipulated by classifying all subjects according to their off-contraception-phase (1 to 6 days before intake of contraception), or to their on-contraception-phase (14th to 18th day after intake of contraception). Both groups of women were instructed to detect target-stimuli in a random sequence of stimulus-presentations (targets or distracters). Targets comprised of dots forming geometric figures or letters. These stimuli were superimposed to a random dot pattern. In contrast to targets, distracters were composed of an equally number of randomly presented dots (without any figure or letter embedded in the random dot-pattern). Simultaneously to the detection task, event-related potentials (ERPs) were collected to link behavioral data to cortical activity. Compared to females in their off-contraception-phase (showing low levels of exogenous sex hormones), females in their on-contraception phase (showing high levels of exogenous sex hormones) demonstrated a significant increase in their ability to correctly detect target-stimuli. Interestingly, ERP-data revealed no behaviorally correlated changes in amplitude, neither for the N2 nor the P3 component. However, analyses of component-latencies demonstrated significant group differences for the N2 and the P3 component. Females in their on-concentration-phase showed significant shortened latencies for the targets and distracters. Behavioral and ERP-data are compatible to the notion of a progesterone mediated modification of transcallosal communication between the hemispheres. Possible implications of our results for the treatment of female schizophrenic patients will be discussed.

A Modality dependent effect in the Corsi tapping task

Andrea Röser, Gregor Hardiess¹, Hanspeter A. Mallot¹

¹University of Tübingen, Cognitive Neuroscience Unit, Dept. of Biology, Auf der Morgenstelle 28, 72076 Tübingen, Germany

Background

The Corsi block tapping task is a widely used paradigm for assessing working memory abilities in humans. In the standard version, a subject is presented with a fixed array of wooden blocks mounted on a board and an interviewer taps a sequence of blocks with the finger. The subject's task is to memorize and repeat the sequence of tapped blocks. The number of blocks correctly reproduced is known as the Corsi or memory span.

Purpose

But, is there a dependency of the Corsi span regarding the modality of task presentation and reproduction? To address this question, we designed two versions of the Corsi task (i.e., a walking and a figural version). Both versions used the same configuration of 15 squares as potential places to remember. In the figural version, the squares were presented on a computer screen. Sequences were presented by highlighting one square at a time. Subjects' recall of such remembered sequences were carried out with a computer mouse. In the walking version, 15 boards were placed in a 5x5 m area providing the potential squares to remember and to walk over during later recall. A computer screen was placed at the entrance of the experimental area, presenting the particular configuration of squares in the same orientation as provided on the floor. For recall, subjects then were asked to walk over the remembered boards in the right order.

Walking and figural versions were tested within the same session; first the walking and then the figural task. During the tasks, the sequence length increased after each fourth trial, from three up to ten. After performing the walking version, the averaged individual walking speed was used to delay the mouse clicks in the figural version in order to adjust the timing in this task. This adjustment should preclude that subjects reach a better performance in figural than in walking version because of different timings.

Results

In both versions of the study the results show a decrease in performance (i.e., proportion of correct trials) with increasing sequence length (fig. A). Furthermore, the Corsi span was different in the two tasks, reaching about 7 in the figural and only about 5 in the walking version. The length of the initial correct section of sequence recall is about 4 in the figural and 3 in the walking version (fig. B).

We conclude that the walking version of the Corsi task requires additional working memory resources not recruited in the figural task. Such resources might be required for mental rotation of the memorized pattern during walking, transfer from the screen monitor on the floor of the experimental room, or the control of walking itself.

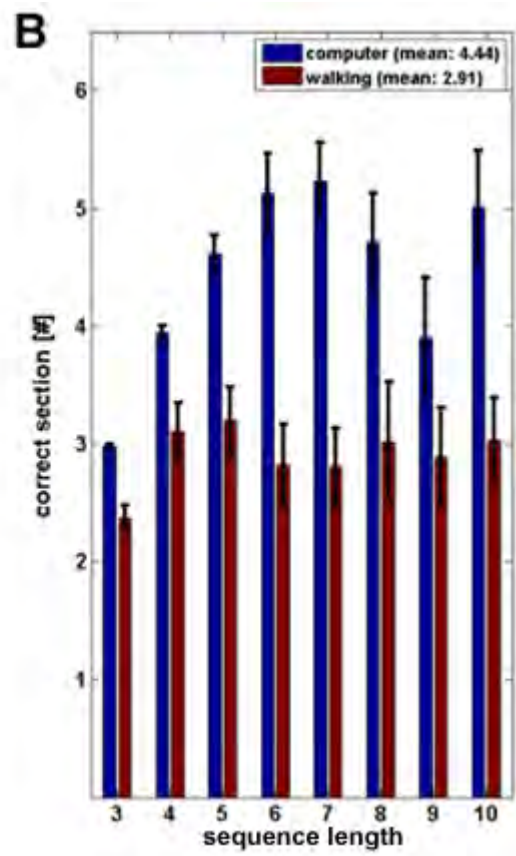
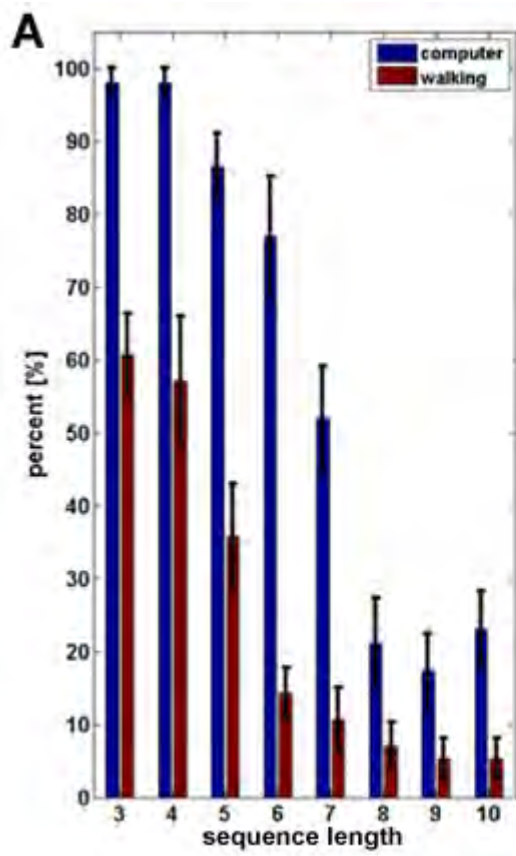

Ego-motion from Optic Flow: Evidence for a Matched Filter Mechanism

Hanspeter A. Mallot¹, Till Becker¹, Fabian Recktenwald¹, Gregor Hardies¹

¹University of Tübingen, Cognitive Neuroscience Unit, Dept. of Biology, Auf der Morgenstelle 28, 72076 Tübingen, Germany

Background: Optic flow plays a crucial role in the perception of ego-motion parameters such as heading, body rotation, or vection. Theoretical approaches of how this is achieved can be classified into three groups differing in the treatment of depth information which is available jointly with ego-motion parameters in the flow field. (i) Direct inversion methods solve the optic flow equation for the ego-motion parameters and a set of “object nearness values”, i.e. the distances to all imaged cues in the scene are recovered. In these approaches, ego-motion and structure-from-motion are thus solved simultaneously. (ii) Decomposition approaches use local differences between 2D motion vectors to split the motion field into a rotatory and translatory component. This approach requires that the imaged scene is not a set of smooth surfaces but contains a sufficient amount of depth discontinuities. Heading then corresponds to the visual direction of the focus of expansion of the translatory component while rotation can be inferred from the poles and vector lengths of the rotatory field. (iii) Matched filter approaches compare the current flow field with reference fields for which the ego-motion is known and estimate current ego-motion from the match. In this approach, the distribution of nearness values over the visual field is assumed constant.

Purpose:

The relation of perceptions of ego-motion and environmental depth was addressed recently by Festl et al. (2012). This study showed that human subjects asked to judge ego-acceleration in random dot motion displays of narrowing and widening corridors completely confuse actual acceleration with changes in corridor width. I.e., translation in narrowing corridors is perceived as acceleration and vice versa. This result is consistent with the matched filter approach where no depth estimates are made. In the Festl et al. study, no independent depth information was available, as viewing was either monocular or binocular with zero disparity. In the present study, we extend the approach of Festl. et al by stereoscopic viewing.

Experiment:

In the experiments, subjects will be presented with stereoscopic displays of pure translations in tubular or conic corridors. Corridors will be visualized as dynamic random dots with limited lifetime. Eleven levels of acceleration/deceleration will be used and subjects will be required to reply to the question “is your motion accelerating?” in a yes-no-task. Psychometric functions for each of the corridor shapes will be recorded.

In strong versions of the matched filter mechanism, we expect again a confusion of ego-acceleration and corridor widening. I.e., psychometric functions for conic corridors will be shifted as compared to the functions for the tubular corridor. If, however, independent depth measurements enter ego-acceleration calculations, we expect more veridical percepts, i.e. coincident psychometric functions for all corridor shape conditions.

1. Festl F, Recktenwald F, Yuan C, Mallot HA (2012) Detection of linear ego-acceleration from optic flow. *Journal of Vision*, 12(7):10,1-12; doi: 10.1167/12.7.10

Imagery of a Familiar Place Varies with Interview Location

Wolfgang G. Röhrich, Niklas Binder¹, Hanspeter A. Mallot¹

¹University of Tübingen, Cognitive Neuroscience Unit, Dept. of Biology, Auf der Morgenstelle 28, 72076 Tübingen, Germany

Background

In spatial cognition the interplay between long-term memory (LTM) and working memory plays an important role in tasks such as spatial planning from a map-like memory, perspective taking, and path-integration. Once learned, spatial LTM will be unaffected by the navigator's current position. Therefore, the current "here" has to be represented in some separate working memory which serves as a pointer to the appropriate place representation in LTM. In spatial imagery ("mental travel") similar pointers to imagined places are likely involved. What do the place representations retrieved via these pointers look like?

Basten et al. (2012) asked subjects to draw views of a familiar place (the Tübingen Holzmarkt) from memory. In this task, subjects prefer particular views which in some sense are characteristic of the place (cf. canonical views in object recognition). For the Holzmarkt, this is the southwards (uphill) view, with a salient church building at the top. When asked to imagine a walk passing the target place in one of two directions, preferred drawing directions change towards the direction of imagined walking. This indicates that direction-specific working memory contents activated during imagined walking bias the recall in the drawing task.

In imagined walking, a representation of one's own position is mentally shifted with respect to a reference memory of space (a cognitive map). This representation is separate from the representation of the subject's true current position, which is not changing.

Purpose

In this study, we address the question whether true current position may affect view-specific recall in a way similar to imagined position. Subjects were approached and interviewed in 14 different places around Tübingen and asked to sketch the 'Holzmarkt' square. Interview locations were either in close walking distance around (but without immediate visual contact to) the Holzmarkt (near condition), or in other quarters of Tübingen about 2 km away (distant condition). Drawings were rated for their main direction in the categories North, East, West, and South.

Results

We confirmed Basten et al.'s finding of a bias for the "South" drawing direction. However, in the near condition, average drawing directions differed significantly between the various interview locations. We calculated the location-dependent component by subtracting the average drawing directions. From the resulting values for the four cardinal directions, a directional vector using circular statistics was obtained (see Figure; the Holzmarkt is marked in yellow). Corrected average drawing directions systematically changed with interview position and roughly point towards the target square. In the far condition no such changes in orientation could be found.

We conclude that the current location can influence the spatial information retrieved from long-term memory if the target place is in walking distance. One might speculate that for close target places, recall involves a mental travel from the interview location (true "here") to the target place (imagined "here"). Recall then happens in the direction of that approach.

1. Basten K, Meilinger T, Mallot HA (2012) Mental travel primes place orientation in spatial recall. *Lecture Notes in Artificial Intelligence* 7463: 378-385.

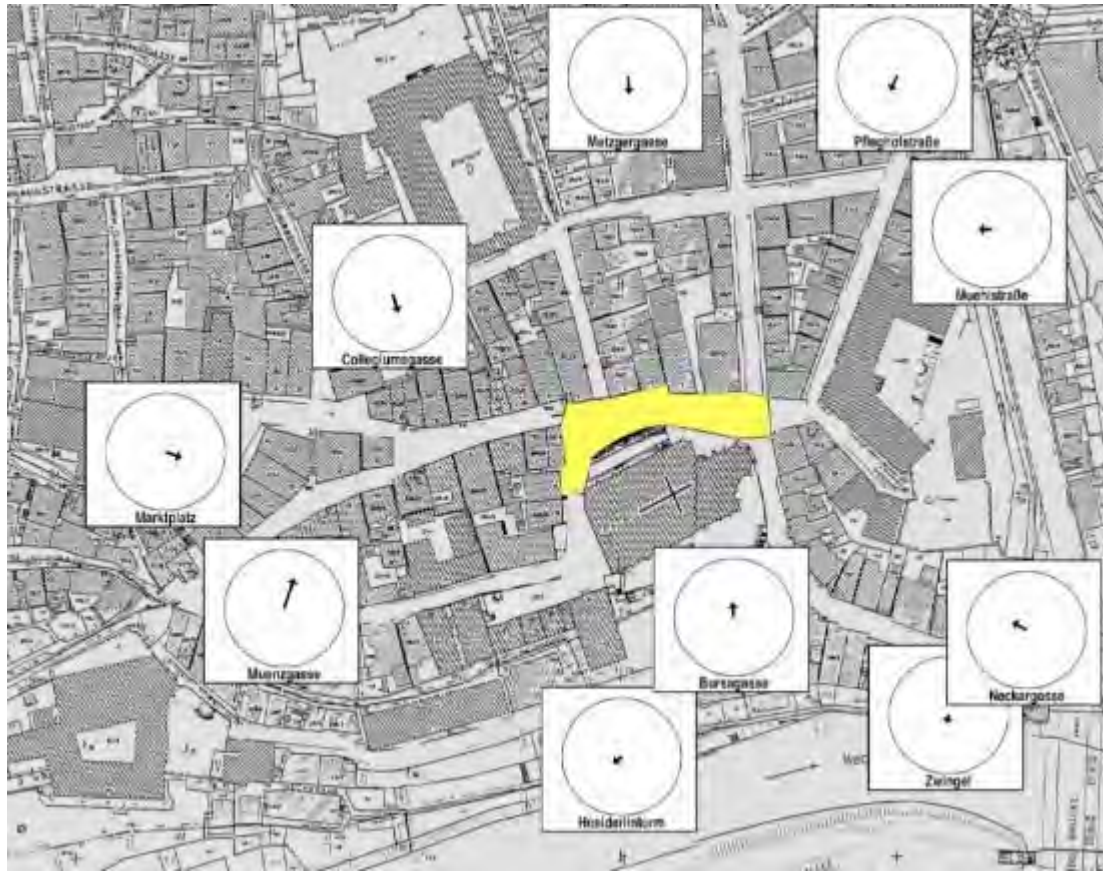

Social defeat in crickets: influences of dopaminergic modulation on the suppression of aggression and its recovery

Paul Anthony Stevenson, Jan Rillich²

¹University of Leipzig, Institute for Biology, Talstrasse 33, 04103 Leipzig, Germany

²Free University of Berlin, Institute for Neurobiology, Koenigin-Luise.-Str. 28-30, 14195 Berlin, Germany

In practically all animals that exhibit intra-specific fighting, the experience of social defeat leads to subsequent suppression of aggressiveness. The underlying mechanisms of this loser effect are, however, largely unknown. In crickets, we have shown that activation of the octopaminergic system mediates the promoting effects of diverse experiences (physical exertion, winning, resource possession) on the expression of aggression (review: Stevenson and Rillich, *Frontiers Neurosci.* 6:118, 2012). We are currently investigating the role of neuromodulator systems in loser depression and report here recent finding suggesting a role for dopamine in its control in crickets. After fighting, defeated crickets flee on confronting the previous winner, but slowly regain their aggressiveness and will fight the previous winner about 3 hours after social defeat. After treatment with the octopamine agonist chlordimeform, losers regain their aggressiveness more rapidly, and will fight the previous winner only 15 mins after defeat. This suggest that the loser effect could result from temporarily diminished octopaminergic signaling after defeat. However, this is probably not the case since treatment with the selective octopamine receptor antagonist epinastine failed to produce any delay in the normal onset of aggressive recovery. Similarly in control experiments, yohimbine, which blocks receptors activated by octopamine's precursor tyramine, also failed to produce any change in the course of recovery of aggression after losing. Contrasting this, the dopamine receptor blocker fluphenazine significantly delayed the recovery of aggression so that losers remained non aggressive 3 hours after defeat. Furthermore, after treatment with homovanillyl alcohol, a metabolite of dopamine, and potent dopamine agonist in insects (Beggs & Mercer, *Current Biology* 19:1206–09, 2009) losers regained their aggressiveness significantly more quickly, and exhibited physical fighting behavior already within 30 mins after defeat. Despite these clear effects on losers, we found no significant effects of fluphenazine or homovanillyl on the aggressiveness of socially naive crickets. In conclusion our data to date suggest that while positive, potentially rewarding experiences (winning, resources) exert their influence on aggression via the action of octopamine (Stevenson and Rillich 2012), dopamine may be involved in conveying the effect of aversive experiences such as social defeat which suppresses aggressive behavior. Supported by the DFG (FOR 1363, STE 714/4-1).

Winners and losers - products of nature or nurture? Evidence for potentially inherent differences in aggression between crickets.

Jacqueline Rose, Darron Cullen², Jan Rillich³, Stephen Simpson⁴, Paul Stevenson¹

¹University of Leipzig, Institute for Biology, Talstr. 33, 04103 Leipzig, Germany

²University of Cambridge, Department of Zoology, Downing Street, Cambridge CB2 3EJ, UK

³Free University of Berlin, Institute for Neurobiology, Koenigin-Luise-Str. 28-30, 14195 Berlin, Germany

⁴The University of Sydney, School of Biological Sciences, NSW 2006, Australia

Social and other experiences have profound influences on the expression of aggressive behaviour. As far as we know in crickets, these effects are short lived. For example, winning leads to a transient increase in aggressiveness lasting some 20-30 minutes, and losing suppress it for a few hours at most. Consequently, the fighting behavior of crickets isolated for several hours appears to be no different to those isolated for 1 or 6 days (Stevenson and Rillich submitted). Surprisingly, therefore, we found numerous behavioural differences between socially isolated crickets that predict aggressiveness and win chances in future contests.

We employed the Ethovision video-tracking system (Noldus) to record the activity of adult male crickets moving freely in an arena (27 x 13.5 cm). For each trial we selected 4 similarly sized crickets (weight difference < 5%) which were isolated for 2 days. Each individual was then video-tracked for 5 min, after which the crickets were matched in pairs to fight. The two winners (W) of the first fights were matched against each other in a second fight, as were the losers (L), to generate a WW that won twice, and a LL that lost two contests. Retrospective evaluation of over 40 sets of tracking data revealed highly significant differences between future WWs and LLs. The future WWs, for example, were more active (i.e. total distance moved, total meander and mean velocity all greater) and spent more time in the vicinity of a small group of other male crickets placed behind a clear screen at one end of the arena. The LLs by contrast tended to avoid the other crickets and visited the edges of the arena more frequently. The results show that the win chances of a cricket in an aggressive contest can be predicted from simple behavioural measures, and suggest further that the expression of aggressive behaviour in crickets is inherently different between individuals. (Supported by the German Research Council, DFG: FOR 1363, STE 714/4-1)

Relief conditioning in rats: Role of the amygdala and the Nucleus accumbens

Markus Fendt

¹Otto-von-Guericke Universität Magdeburg, Pharmakologie und Toxikologie, Leipziger Str. 44, 39120 Magdeburg, Germany

During Pavlovian fear conditioning, stimuli predicting aversive events are learned as fear stimuli. This means that later such stimuli alone are able to induce fear which involves physiological and behavioral changes preparing animals or humans for further aversive events. Fear learning is best when the to-be-learned stimulus immediately precedes the aversive event. However, what happens if the to-be-learned stimulus follows the aversive event, in the moment of relief? Studies in *Drosophila* demonstrated that such a stimulus can also be learned. However, the stimulus does later not induce fear responses like avoidance behavior but appetitive responses like approach behavior. This phenomenon was called relief conditioning.

Here, first studies on relief conditioning in rats are presented. First, we developed a protocol for relief conditioning in rats. As a behavioral measure, we used the acoustic startle response. If during conditioning a light stimulus was presented three seconds after an aversive stimulus, this light stimulus later induced a significant attenuation of the startle magnitude which is regarded as an appetitive response. If the light stimulus is presented six or more seconds after the aversive event, only a weak startle attenuation was measured which we interpreted as safety conditioning. Presentation of the light stimulus before the aversive stimulus induced – as expected – fear conditioning.

Then, the role of the amygdala and the nucleus accumbens in relief conditioning was investigated. After relief or fear conditioning, either the amygdala or the nucleus accumbens were temporally inactivated (by local injections of the GABA-A receptor agonist muscimol) and the animals were tested for conditioned relief or conditioned fear, respectively. Inactivation of the nucleus accumbens but not of the amygdala blocked the expression of conditioned relief. In contrast, inactivation of the amygdala blocked conditioned fear without affecting conditioned relief. Thus the behaviorally opponent memories supported by the onset and the offset of aversive events are mediated by different neural substrates.

Currently, we are investigating which transmitter system and receptors within the nucleus accumbens are involved in the learning and retrieval of conditioned relief.

Perceptual Changes and Emotional Impact of Sensory Augmentation

Sabine Ursula König, Jessika Schwandt¹, Kai Kaspar¹, Peter König^{1,2}

¹Institute of Cognitive Science, University of Osnabrück

²Institute of Systems Neuroscience, University Medical Center Hamburg Eppendorf

Enacted theories of consciousness conjecture that perception and cognition arise from an active experience of the regular relations that are tying together sensory stimulation and associated motor actions [1,2,3]. Previous experiments [4] explored this hypothesis employing the technique of sensory augmentation with the feelSpace belt. This belt maps directional information measured by a compass to a set of vibrators by activating the element pointing north. Here we systematically investigate perceptual changes induced by an improved device for sensory augmentation in a larger cohort.

The new device is a belt consisting of 30 piezoelectric vibrotactile actuators, a compass, a control-box and battery packs (Fig A). 9 subjects wore the belt during all waking hours over a period of 7 weeks training in natural environment. 5 additional subjects formed the control group. We combined daily diaries, weekly evaluations (questionnaires and interviews), and psychometric tests to assess changes in sensory experiences.

We find that

- appeal and usability of the feelSpace belt was high throughout the training period (Fig B).
- over time the tactile perception diminished; was less consciously perceived; subjects had to concentrate less to use the belt signal; after taking the belt of phantom vibrations occurred less frequently; instead the signal was more perceived as location or directional information (Fig C, items 1-5 respectively).
- 8 out of 9 subjects reported qualitative changes in perception of space, e.g. „Es ist ein wirkliches Raumgefühl, unvermittelt durch Sinne wie Sehen und Hören, oder Propriozeption (...). Irgendwie stellt sich auch ein Gefühl für Fernpräsenz ein: Sehen und Hören vermitteln nur Nahes/Anwesendes, der Gürtel aber auch Abwesendes von Sehen & Hören.“ In general, perceived space was described as getting wider and including areas that are not directly visible or tangible.
- Subjects reported an increase in several aspects of spatial orientation, e.g. “Zuvor waren die (mentalen) Karten eher aus Vogelperspektive, während nun die Karten aus Ego-Perspektive auf das erlebte Sehen projiziert sind. (...) Auch sind es weniger klare Karten als Wege. Ich kann nur noch schwer mentale Karten bilden (...). Stattdessen navigiere ich nach Gefühl.” They improved their orientation and navigational performance in their own estimation (Fig D).
- For the subjects the most important effect of the belt was an enhanced feeling of security in known and unknown surrounding. „Ich glaube aber, dass ich das permanente Wissen um den nördl. HR sehr missen werde, da es schon ein Gefühl der Sicherheit (...) ist.“ „Auch wenn ich mich ohne Gürtel an einem Ort ganz genauso auskennen oder zurechtfinden würde, so fühle ich mich mit Gürtel trotzdem wohler und sehr sicher, dass ich überall problemlos hinfinden würde.“

The presented results are compatible with enacted theories of conscious perception and demonstrate the pragmatic utility of the feelSpace belt.

1. Merleau-Ponty M (1962) Structure of behavior. Boston: Beacon Press.
2. Noë A (2004) Action in perception. Cambridge, MA: MIT Press.
3. O'Regan JK (2011) Why Red Doesn't Sound Like a Bell: Understanding the feel of consciousness. Oxford University Press .
4. Nagel SK, Carl C, Kringe T, Märtin R, König P (2005) Beyond sensory substitution – learning the sixth sense. J Neural Eng 2.

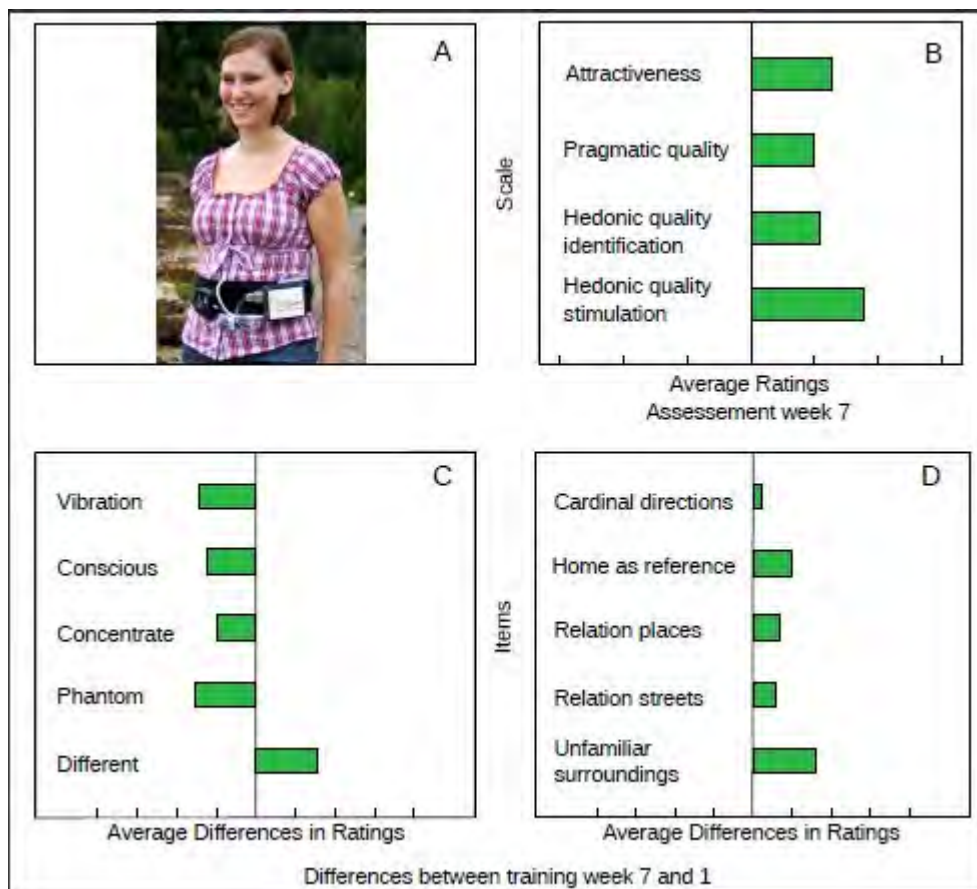

Stimulus salience enhancement at the expense of accurate representation: MT responses to transient direction changes and their attentional enhancement

Vahid Mehrpour, Julio C. Martinez-Trujillo², Stefan Treue^{1,3}

¹Cognitive Neuroscience Laboratory, German Primate Center, Kellnerweg 4, 37077 Göttingen, Germany

²Cognitive Neuroscience Laboratory, Dept. of Physiology, McGill University, 3655 Prom Sir. W. Osler, Montreal QC H3G 1 Y6, Canada

³Bernstein Center for Computational Neuroscience, Göttingen, Germany

Neurons in the Medial Temporal area (MT) of the visual cortex of rhesus monkeys are tuned to the direction of visual motion in their receptive fields (RFs). These neurons play a central role in the perception of visual motion. Their activity has also been shown to be modulated by the attentional relevance of the encoded stimulus. Typically this modulation is assessed in a paradigm where the animal is trained to respond to the detection of a direction or speed change in a moving random dot pattern. The attentional modulation is present in the steady-state period before the change in the stimulus. The response to the change itself and the attentional modulation of this change response has not been investigated extensively and is the focus of our study.

We investigated how the tuning properties of MT cells are affected by transient motion direction change applied in the visual motion stimulus placing in their receptive fields in two attentional circumstances. Visual responses of direction-selective MT single cells were recorded from two rhesus monkeys trained to perform a direction change detection task: while the animal foveates a central fixation point, a static random dot pattern (RDP) is briefly presented either inside or outside the RF cuing the target's location. Motion changes at other (distractor) locations were behaviorally irrelevant and had to be ignored. After the cue presentation two moving RDPs (the target and a distractor) were shown one inside and one outside the RF. At randomly chosen periods of time the direction of the target or the distractor transiently (for 200ms) changed by 20°, 25°, 30° or 35°. The monkey had to indicate the target change by releasing a lever. The tuning curve of each MT cell was determined in two time windows, immediately before and after the change event happens inside the RF, by fitting the average firing rate of the neuron to each of the 12 directions used with a circular Gaussian function. Two such curves were measured, one with the target stimulus and one with the distractor in the receptive field.

The results show that the transient motion direction change significantly shifts preferred direction of the population of direction selective MT but does not change the other tuning parameters (baseline, maximal response and tuning width). In addition, when the RF stimulus was the target, i.e. when attention was directed towards the stimulus that underlies the neuron's response the change in preferred direction with the stimulus change was larger than for the unattended (distractor) stimulus.

The results show that MT is well-suited to encode sudden changes in the motion direction in their RF. Even if this change is behaviorally irrelevant the MT responses inflate the direction change, as if to make it more salient. This is reminiscent of contrast enhancement mechanisms throughout the visual system. In addition, attention further enhances this effect suggesting that the task of attention is not only to increase an attended stimulus sensory strength relative to unattended stimuli but also to enhance relevant stimulus aspects (such as the change in our experiment) even at the expense of an accurate representation of the physical stimulus parameters.

Probing numerosity-selectivity in neurons of the association cortex of numerically-naïve monkeys

Pooja Viswanathan, Andreas Nieder¹

¹Animal Physiology, Institute of Neurobiology, University of Tübingen, 72076 Tübingen, Germany

While recent years brought significant advances in our understanding of the neural substrates and mechanisms that represent numerical quantities, little is known about the development of numerosity selectivity in the brain. Work from our group has shown that single neurons in the parietal and frontal association cortices encode visual set sizes. So far, these investigations have been done exclusively in animals extensively trained to discriminate magnitude, consequently raising the possibility that aspects of neuronal numerosity selectivity might be shaped by learning and experience. Whether numerosity detectors similar in number and response characteristics also exist in naïve animals remains untested.

Here, we investigate neuronal numerosity selectivity in a naïve rhesus monkey when the numerosity has no behavioral or task relevance. The monkeys performed a delayed match to sample color task where they matched the color of a sample array to that of test arrays presented sequentially after a delay period. A color match was reported by releasing a bar held throughout the trial and rewarded subsequently. To address spontaneous selectivity to numerical quantity, the stimulus displays consisted of visual arrays of colored dots with varying numbers of items from one to five. The monkeys received no numerosity training and no relevance was associated with the numerosity information in the stimuli. Subsets of stimuli controlled for low-level stimulus parameters: colored area and density of dots across numerosities. After the monkeys mastered color discrimination, we recorded multi-channel single-unit activity (Plexon system) from the dorsolateral prefrontal cortex (PFC) and the ventral intraparietal area (VIP) of the posterior parietal cortex while the monkeys performed the color discrimination task. Based on average discharge rates during sample and delay periods separately, we determine color-selectivity and numerosity-selectivity of single units. A three-factorial analysis of variance (ANOVA, $p < 0.01$) was calculated with numerosity (one to five), color (five different colors) and stimulus protocol (standard vs. size and density control) as factors.

Neurons recorded from prefrontal cortex (PFC) and ventral intraparietal area (VIP) show significant modulation of discharges to numerosity of the stimuli apart from other task related modulation. A tuning to the sample numerosity was seen during the sample and delay periods of the tasks. A large fraction of these neurons did so unaffected by low level visual features of the stimulus. We found neurons that discharged maximally to one of the five shown numerosities, with a gradual drop-off of activity for numerosities contiguous to the preferred numerosity, resulting in peak-tuned numerosity-tuning curves.

These preliminary data show that neurons tuned to abstract numerical quantities do exist in the brains of monkeys that have not been trained to discriminate quantities (i.e. 'numerically-naïve' monkeys). Such numerosity-selective neurons are found in both VIP and PFC. Moreover, cardinal tuning seems to be a default mechanism of numerosity encoding rather than an artifact of discrimination training. Future analysis has to compare the frequency and/or tuning properties in numerically-naïve monkeys to those in highly-trained animals.

Context-dependent coding flexibility of numerosity-selective neurons in the primate prefrontal cortex.

Maria Moskaleva, Andreas Nieder¹

¹University of Tuebingen, Institute of Neurobiology, Animal Physiology, Auf der Morgenstelle 28, 72076 Tuebingen, Germany

The prefrontal cortex (PFC) operates at the apex of the cortical hierarchy and enables nonhuman primates and humans with unprecedented cognitive flexibility. To achieve this cognitive flexibility at the interface between sensory input and motor output, PFC neurons need to adaptively code almost any behaviorally relevant feature of the environment. Previous work with nonhuman primates showed that PFC neurons can represent groups of behaviorally meaningful stimuli, or categories. After the monkeys were retrained to respond to other category boundaries than before, the neural representation changed accordingly. Such change in coding properties appeared after extensive retraining and thus required long-term memory. However, cognitive flexibility requires an instantaneous change of coding properties according to current task demands at hand. How PFC neurons achieve this coding flexibility is poorly understood. We therefore investigated if and how PFC neurons dynamically adapt to changes of the number of categories a monkey is facing.

We trained a rhesus monkey to discriminate categorical stimuli in a delayed match-to-sample task. In this protocol, a monkey was presented with a sample stimulus, then after a delay period, a test stimulus was presented, which either matched the sample in the relevant feature or not. To receive a reward, the monkey was required to respond if the test stimulus matched the sample stimulus. Three different sets of stimulus dimensions were used in this task: colors, line lengths and numerosities (i.e. number of dots in a set), each in three different modifications (e.g. numerosities 1, 2, and 4). The different stimulus dimensions were presented in two different blocks within each experimental session. During the 'mixed block', color, line length and numerosity trials were presented in a pseudo random order. During the 'numerosity only block', only numerosity trials were presented. After the monkey proficiently mastered this task, we recorded single-cell activity from multiple electrodes inserted into the PFC centered around the principal sulcus. Coding of the three different numerosities was evaluated with an ANOVA ($p < 0.05$). This protocol allowed the tracking of neural coding of the numerosity category as a function of context in which the numerosity match-to-sample task was presented (i.e. 'mixed block' vs 'numerosity only block').

Preliminary results show that about 40 % of PFC neurons were numerosity selective during at least one block. Consistent with earlier findings in the PFC, these cells displayed characteristic tuning to numerosities. The cells showed the highest discharge rate to one 'preferred' numerosity. These responses decreased with increasing distance from the preferred numerosity. During the 'mixed block', discharge to non-preferred numerosities tended to be lower than during the 'numerosity only block' (resulting in sharper tuning in the 'mixed block'). Moreover, the number of numerosity selective cells seemed to be increased during the 'mixed block' (32 % vs. 26 % in the 'numerosity only block').

These results suggest that the overall context of the numerosity discrimination has an immediate impact on the coding properties of PFC neurons. In other words, the PFC might adjust to the task context so that the tuning properties and the frequency of numerosity selective neurons may change as a function of task context.

Prefrontal neurons encode volitional initiation of monkey vocalizations

Steffen R Hage, Andreas Nieder¹

¹University of Tübingen, Animal Physiology, Auf der Morgenstelle 28, 72076 Tübingen, Germany

Language is one of the key defining features of humans, allowing us most sophisticated audio-vocal communication. Vocal utterances of our closest primate relatives, however, are genetically pre-programmed and generally assumed to be highly affective and tightly bound to specific motivational states. These differences between speech and vocalization are also reflected in the underlying neuronal network. Learned vocal patterns such as human speech are produced primarily by cortical areas, with Broca's area in the ventro-lateral frontal lobe as key structure for voluntary speech production. In contrast, genetically pre-programmed vocalizations are generated by a complex neuronal network in the brainstem. Whether nonhuman primates can decouple their vocal output from the accompanied motivational state and instrumentalize them in a goal-directed way remains a matter of debate. If proven so, however, this would offer to address precursors of vocal control in monkeys, since recent studies suggest a monkey homologue of Broca's area (BA 44 and 45) sharing anatomical and physiological similarities with Broca's area.

We trained two rhesus monkey to perform a computer-controlled go/nogo detection task by using their vocalizations as a response. They were required to vocalize cued by arbitrary visual stimuli to receive a reward. We show that rhesus monkeys can be trained to elicit vocalizations on command in response to arbitrary visual cues. This indicates volitional control on vocal behavior in monkeys, an obligate precursor for the evolution of speech in the primate lineage.

With this approach, we had the opportunity to study the role of BA 44 and 45 in volitional vocal behavior. We performed single-unit recordings from 956 neurons in BA 44 and 45 and BA 6 in both monkeys which were trained to vocalize on command. Hereby, we recorded call-related neurons that specifically predicted the preparation of instructed vocalizations in BA 44 and 45. The activity of many call-related neurons prior to vocal output was correlated with call parameters of subsequent instructed vocalizations. These findings suggest a cardinal role of the monkey homologue of Broca's area in vocal planning and call initiation, a putative cognitive precursor in nonhuman primates that may ultimately give rise to speech control in linguistic humans.

In summary, we established a primate model to study evolutionary aspects of human speech control. Our findings suggest a cardinal role of the monkey homologue of Broca's area in vocal planning and call initiation. BA 44 and 45 in the ventral prefrontal cortex of nonhuman primates might constitute a phylogenetic precursor for speech control in linguistic humans. We show that the monkey homologue of Broca's area and adjacent areas are involved in executing volitional vocal behavior.

The role of dopamine in risk-based decision making in rats

Bettina Mai, Wolfgang Hauber¹

¹Universität Stuttgart, Biologisches Institut, Abt. Tierphysiologie, Pfaffenwaldring 57, 70550 Stuttgart, Germany

For optimal decision making in an uncertain and changing environment animals often need to evaluate of the expected costs and benefits of the available response options, e.g. the magnitude and likelihood of rewards associated with alternative courses of action. Considerable evidence suggests that animals as diverse as fish, birds and mammals are able to estimate the probability (“risk”) of obtaining different rewards when making decisions which course of action to choose [1]. Brain dopamine (DA) systems are critically involved in risk-based decision making, however, as yet little is known about the contribution of DA signals in target regions of midbrain DA neurons in controlling risk-based decision making.

Here we sought to characterize the role of DA in risk-based decision making in more detail. First, we examined in rats the effects of DA depletions in the medial prefrontal cortex (mPFC; experiment 1) and nucleus accumbens core (AcbC; experiment 2) in a probabilistic choice task. In each session, probabilities of reward delivery after pressing one of two available levers were signaled in advance in forced trials followed by choice trials which assessed the animal’s preference. The probabilities of reward delivery associated with the large/risky lever declined systematically across 4 consecutive blocks but were kept constant within 4 subsequent daily sessions of a particular block. Thus, in a given session, rats need to assess the current value associated with the large/risky vs. small/certain lever and adapt their lever preference accordingly. Results demonstrate that the assessment of within-session reward probabilities and probability discounting across blocks was not altered in rats with mPFC and AcbC DA depletions relative to sham controls. These findings suggest that the capacity to evaluate the magnitude and likelihood of rewards associated with alternative courses of action seems not to rely on intact DA transmission in the mPFC or AcbC.

In experiment 3, we tested in a modified probabilistic choice task whether an activation of brain DA systems can alter risk-based decision making. In line with earlier findings [2], systemic administration of the indirect DA agonists d-amphetamine or cocaine increased risk taking. In experiment 4, we tested whether increased DA signaling in the mPFC or AcbC could account for the effects of amphetamine on risk-based decision making observed in experiment 3. Specifically, we examined whether cell body lesions of the mPFC or AcbC are able to reverse increased risk taking induced by systemic amphetamine. Preliminary results tentatively suggest that effects of amphetamine on risk-based decision making are in part mediated by the AcbC.

Overall, our findings suggest that the capacity to evaluate the magnitude and likelihood of rewards associated with alternative courses of action seems not to rely on intact DA transmission in the mPFC or AcbC. However, abnormal DA signaling in the AcbC, e.g. as result from drug intake, may alter risk-based decision making. Furthermore, it is important to note that effects of DA manipulations on risk-based decision making critical depend on the probabilistic choice task being used.

Supported by the DFG HA 2340/9-1

References:

1. Kacelnik, A., and M. Bateson, *Trends Cogn Sci.*, 1997.1(8): p. 304–309.
2. Floresco S.B., J.R. St Onge, S. Ghods-Sharifi, and C.A. Winstanley, *Cogn Affect Behav Neurosci.*, 2008. 8(4): p. 375-89.

Acute stressor effects on goal-directed action in rats

Wolfgang Hauber, Stephanie Braun¹

¹Universität Stuttgart, Abt. Tierphysiologie, Pfaffenwaldring 57, 70550 Stuttgart, Germany

Two interacting learning systems govern the performance of instrumental action, one controls the acquisition of goal-directed actions, another the acquisition of habits. The acquisition of goal-directed actions is driven by causal relations between actions and outcomes and, hence, sensitive to changes of action-outcome contingencies and outcome devaluation. By contrast, the acquisition of habits is driven by stimulus-response relations and insensitive to changes of action-outcome contingencies or outcome devaluation. Goal-directed actions are flexible and can be adapted to changing environments, whereas habits are inflexible and performed almost automatically allowing attention to be focused elsewhere.

Importantly, acute stress in humans can modulate processes governing instrumental learning in a manner that favors habit learning over goal-directed learning. Specifically, in an instrumental learning task, unlike control subjects, subjects exposed to acute stress became insensitive to outcome devaluation indicating that responding became inflexible and was driven by habits. These acute stress effects on instrumental learning can be mimicked by an increased glucocorticoid/noradrenergic activity elicited through co-administration of the glucocorticoid hydrocortisone and the α_2 -adrenoceptor antagonist yohimbine¹. However, it is as yet unknown whether acute stress in animals can shift instrumental responding from goal-directed to habitual control as shown in humans.

Here we examined the effects of acute stressors that involve one or several distinct restraint stressors (denoted here as “single” vs. “multiple” stressor) or co-administration of corticosterone/yohimbine on goal-directed action in rats by testing for their sensitivity to outcome devaluation. Like control rats, rats subjected to stimulation of glucocorticoid/ noradrenaline activity or to a single restraint stressor were sensitive to outcome devaluation. Likewise, rats exposed to a multiple restraint stressor were sensitive to outcome devaluation; however, relative to control rats, their sensitivity was markedly reduced. Results indicated that reduced sensitivity to outcome devaluation may reflect impaired instrumental performance rather than habitual response control. Pretreatment with the anxiolytic drug diazepam (1 and 2 mg/kg, i.p.) did not alleviate impaired instrumental performance elicited through multiple stressor exposure.

Thus, in rats acute stressors and concurrent glucocorticoid/noradrenaline activity did not affect retrieval of encoded relationships between actions and their consequences. In rats, the expression of action-outcome learning may be insensitive to acute stressors in particular because, unlike in humans, the acquisition of goal-directed action requires repeated action-outcome learning over several sessions. Considerable evidence from studies in humans revealed that acute stress can modulate interactions of learning and memory systems controlling goal-directed instrumental action and facilitates habitual action at the expense of goal-directed action¹. Yet, in rats under acute stress the expression of goal-directed actions is still flexible and can be adapted to changing environments, thus, the extent to which acute stress can impair the expression of goal-directed action may critically depend on the amount of action-outcome learning that varies across species.

Supported by the DFG HA2340/8-1.

References:

¹ Schwabe et al. 2012 *Neurosci Biobehav Rev* 36:1740-1749.

Prefrontal cortex neurons represent abstract rules applied to multiple magnitudes

Anne-Kathrin Eiselt, Andreas Nieder¹

¹University of Tuebingen, Institute of Neurobiology, Auf der Morgenstelle 28, 72072 Tuebingen, Germany

The ability to process abstract quantity information is central to intelligent, goal-directed behavior. If and how single neurons represent quantitative rules applied to different magnitudes in a single session, however, remains elusive. To investigate the neural basis of task shifting based on magnitude information, we trained rhesus monkeys to perform magnitude comparisons based on switching rules. The monkeys needed to apply quantitative rules to three classes of magnitudes: numerosity (discrete numerical magnitude), the length of a line (continuous spatial magnitude) and the spatial frequency of a sine wave grating (basic sensory magnitude). Monkeys successfully learned this highly demanding task and judged whether a test magnitude was either higher/longer/greater or lower/shorter/less than the sample magnitude with a performance rate significantly above chance level. They also generalized to novel sample magnitudes that had not been presented previously, indicating their abstract understanding of the different rules. Single-cell activity recorded from prefrontal cortex (PFC) neurons in behaving monkeys revealed different populations of rule-selective neurons. Of 253 randomly selected prefrontal cortex neurons, 15.4 % encoded the abstract magnitude rule for the numerosity stimuli, 20.2% for the line length stimuli and 22.1% for the frequency stimuli. Overall, almost 40% of all recorded neurons were significantly encoding the magnitude rules. In addition to neurons that specifically encode the rule always in conjunction with the magnitude type (specialists, around 60% of all rule selective cells), we found a population of neurons that encode the rule irrespective of the magnitude type (generalists, almost 40% of all rule selective encode the magnitude rule for at least two magnitudes). Within these generalizing cells 20% (8 out of 39) are encoding the rule for all three magnitude types, which is more than would be expected by chance. This indicates that the different magnitude rules are not only treated as independent principles, but that a population of neurons is multitasking and therefore generalizing across magnitude categories.

Effect of intense physical activity on Individual alpha frequency (IAF) and Fatigue index (FI).

Irina S. Polikanova, Aleksander G. Tonevitsky¹

¹Lomonosov Moscow State University, department of psychophysiology, Mokhovaya st. 11/9, 125009 Moscow, Russia

The goal of the study was to examine the effect of intense physical activity on EEG parameters – Individual alpha frequency (IAF) and Fatigue index (FI, ((alpha+theta)/beta)).

Methods.

Nine male student-wrestlers (mean age 19+/-1) perform short block of tests including subjective assessment of their current state (health, activity and mood questionnaire), time reactions tests (simple reaction task (SRT) and choice reaction task (CR)). This block was performed in the baseline condition and within 15-30 minutes after the intense physical exercise (combat wrestling training for 1 hour with the mean heart rate HR 159+/-7). Before each block the resting EEG (256 channels, sampling rate 500 Hz, with vertex reference) was recorded. The EEG parameters – Individual alpha frequency (IAF) and Fatigue index (FI) were measured and averaged in five separate regions (frontal, central, temporal, parietal and occipital) for both hemispheres. The statistical analysis package Statistica 8 (for Windows, V 8.0, StatSoft) and MatLab (R2007b) were used for data analysis.

Results.

In subjective state assessment after intense physical training there was observed the significant enhancement of “activity” scale (4,68 vs. 5,38). Some authors also reported that physical exercises have a positive impact on the state of health. Dishman showed the positive effects after 6 weeks of exercise training on feelings of vigor and fatigue among college students who reported persistent fatigue (Dishman, 2010).

In SRT there were not any significant differences after physical load (238,85 (54) vs. 239,34 (51)). In CR task there was slight decrease in time reaction (403,25 (91) vs. 388,58 (92)), but not significant. In several studies it was shown that after physical trainings the significant changes in reaction time was not observed (Korobeynikov, 2006; Terrier, 2009).

The results of ANOVA have shown no differences in IAF frequency, but ANOVA have shown significant differences in IAF power between baseline and after load conditions ($F(1,50)=4,3274$; $p<0,05$). Wilcoxon test have shown significant decrease of IAF frequency only in Occipital Right region (10,09 (0,67) vs. 9,79 (0,61)) and have shown significant increase of IAF power in Frontal, Central and Temporal regions of both hemispheres. The ANOVA results of Fatigue index have shown no significant differences between baseline and after load conditions.

Many studies showed decrease of IAF and increase of FI after prolonged cognitive load and linked it with tiredness and fatigue development. Some studies also showed the decrease in frequency of IAF after physical activity (Ng et al., 2007). In our study we obtained extensive statistical increase of IAF power in all participants after physical load. And in IAF frequency some subjects were characterized by increase and some by decrease of frequency. So, we showed that IAF power can be used as more objective marker of physical fatigue.

Iontophoretic stimulation of dopamine D1 receptor enhances numerical rule coding in the primate prefrontal cortex

Torben Ott, Simon N Jacob¹, Andreas Nieder¹

¹Animal Physiology, Institute of Neurobiology, University of Tübingen, Auf der Morgenstelle 28, 72076 Tübingen, Germany

The ability to process abstract quantity information to achieve internally maintained goals is central to intelligent, goal-directed behaviour. Numerical competence, the capability to use quantities and numbers, is based on highly abstract principles, or rules, of how to structure, process and evaluate quantitative information. Numerical competence thus inherently requires executive control functions. We have shown previously that single neurons in the primate prefrontal cortex (PFC) encode abstract numerical rules. The cellular mechanisms giving rise to the rule-related neuronal activity are, however, poorly understood. Since the PFC receives strong projections from the dopaminergic midbrain modulating executive functions such as working memory, we hypothesized that dopamine receptors in the PFC are involved in regulating abstract rule coding.

To test our hypothesis, we trained two rhesus monkeys (*Macaca mulatta*) to compare numerosities and to switch flexibly between two abstract mathematical rules. The “greater than” rule required the monkeys to release a lever if the first test display showed more dots than the sample display, whereas the “less than” rule required a lever release if the number of items in the test display was smaller compared to the first test display. For each trial, the rule to apply (“greater than” vs. “less than”) was indicated by a cue that was present in the delay between sample and test stimuli. To dissociate the neural activity related to the physical properties of the cue from the rule that it signified, two distinct cues from different sensory modalities were used to indicate the same rule, whereas cues signifying different rules were from the same modality.

We recorded single neurons in the lateral PFC while simultaneously applying the dopamine D1 receptor (D1R) agonist SKF81297 to the vicinity of the cells using microiontophoresis. Our preliminary data show that single neurons encoded the abstract “greater than” and “less than” rules. After application of the D1R agonist, neuronal activity related to the numerical rules was enhanced. Importantly, the quality of rule coding was significantly improved by stimulating the D1R compared to control conditions. We hypothesize that further recordings using the D1R antagonist SCH23390 might show that blocking the D1R impairs numerical rule coding. These results suggest that dopamine is involved in modulating prefrontal rule-coding units to guide behaviour.

Neural correlates of abstract task-switching in carrion crows

Lena Veit, Andreas Nieder¹

¹University of Tübingen, Animal Physiology, Institute of Neurobiology, Auf der Morgenstelle 28, 72076 Tübingen, Germany

Even though they lack a layered neocortex, birds, particularly corvids, have been shown to match or surpass primates in many cognitive tasks. The associative forebrain areas underlying these abilities evolved independently from different anatomical structures of the telencephalic pallium in birds and mammals. Therefore, the investigation of the neuronal mechanisms underlying cognitive functions in corvid birds will help to decipher the general principles and evolutionary constraints for the design of highly cognitive vertebrate brains.

To study the neural underpinnings of executive control functions in corvids, we trained two carrion crows (*Corvus corone*) on an abstract rule-switching task which required them to flexibly apply rules to match two identical or two different visual images, respectively. The birds were positioned in front of a touchscreen monitor and presented with an arbitrary image, which they had to hold in working memory. After a short delay, a rule cue instructed the bird about the behavioral rule to apply in the current trial. After another delay period, the birds indicated their choice by pecking the appropriate stimulus from a choice array consisting of the sample image and one other image from the daily stimulus set. They mastered this delayed rule-switching task with two sets of rule-cues from different modalities and novel sets of sample images each day (average performance 88.8% correct). To exclude any reliance on learnt stimulus-specific response associations, we presented one session with trial-unique sample and nonmatch images that the birds had never seen before. Performance in these transfer tests was indistinguishable from baseline performance with familiar images ($p > 0.05$, chi square test). Thus, the crows can indeed grasp abstract same/different concepts and apply them flexibly to arbitrary stimuli held in working memory.

We next recorded the activity of single neurons in the NCL (nidopallium caudolaterale), a proposed avian analogue of the mammalian prefrontal cortex (PFC). We found single NCL-neurons which showed elevated activity to one of the two behavioral rules. To control whether cells were merely responding to sensory properties of the rule cue, each rule (same or different) was instructed using one of two rule cues from different modalities. Many of the neurons encoded only the behavioral rule, abstracting over different sample images and the modality of the rule cue. In trials when the birds made an error, rule coding was weaker or even reversed, suggesting that the activity of the recorded neurons was relevant to the birds' behavior on a trial-by-trial basis.

This represents, to our knowledge, the first combined recording of behavior and single unit activity in awake behaving corvids, introducing crows as a promising new model to study the neuronal basis of

high-level cognition. The rule-coding NCL neurons resemble abstract rule neurons found in the primate PFC using very similar paradigms. Thus, there seems to be similar encoding of the task by rule-selective neurons in two functionally equivalent associative forebrain areas of different evolutionary origin. This suggests that animals which are able to learn this cognitively demanding task found similar neurophysiological solutions through convergent evolution.

Saliva estradiol level predicts individual alpha frequency in women

Christina Brötzner, Wolfgang Klimesch², Michael Doppelmayr², Hubert H. Kerschbaum¹

¹University of Salzburg, Department Cell Biology, Hellbrunnerstr. 34, 5020 Salzburg, Austria

²University of Salzburg, Department of Psychology, Hellbrunnerstraße 34, 5020 Salzburg, Austria

Changes in estradiol level are reflected in changes in neuronal activity. For example, in rodents, an increase in estradiol is associated with spine formation, change in synaptic transmission and long term potentiation (McEwen, B., *Recent Prog Horm Res.* 57:357-84, 2002). In women, menstrual cycle phase level is associated with structural changes in hippocampal and parahippocampal areas (Protopopescu, X. et al., *Hippocampus*, 18: 985-8, 2008; Pletzer, B. et al., *Brain Res.* 1348: 55-62, 2010). Taking into consideration the noticeable structural and physiological estradiol-dependent changes in the brain, it is not surprising that cognitive and emotional parameters changes during the menstrual cycle (Cahill, L., *Nat Rev Neurosci.* 7: 477-84, 2006). At the electroencephalography (EEG) level, alpha oscillations set the rhythm for early categorization processes and suppression of irrelevant information (Klimesch, W. et al., *Brain Res. Rev.* 53: 63-88, 2007). Detailed EEG studies documented that working memory capacities and perception are closely correlated to the individual alpha frequency (IAF) (8 – 12 Hz) (Klimesch, W. et al., *Prog Brain Res.* 159: 151-65: 2006). In general, high IAF predicts better performance in working memory tasks and perception. Endogenous estradiol level does not only fluctuate during the menstrual cycle of a woman, but shows large variability among women. Because of the close association between IAF and performance in cognition tasks as well as menstrual cycle phase and cognitive performance, we studied whether estradiol predicts the IAF.

18 women with a naturally menstrual cycle participated in our study. We recorded an EEG from each woman during early and late follicular phase and during the luteal phase. In each of the three EEG sessions we collected saliva and quantified estradiol using an ELISA. In a visual-spatial cued attention task, participants had to discriminate between “p” and “q”. Error rates and response times were monitored (Sauseng, P. et al. *Frontiers in Psychology*, 241: 1-9, 2011).

We found a close association between estradiol and IAF in women with a naturally menstrual cycle. Low estradiol levels correlated with high and elevated estradiol levels correlated with low IAF. The most pronounced association between estradiol level and IAF was found in the late follicular phase (close to ovulation). During early follicular and luteal phase an association was noticeable but not statistically significant. Furthermore, lower alpha power was larger in individuals with high estradiol compared to individuals with low saliva estradiol level. Alpha power differed between hemispheres. We found consistently EEG asymmetries in the frontal cortex. Power of alpha was larger in left than in right frontal cortex. In parietal and occipital areas power was larger in the right hemisphere. In the visual-spatial cued attention task estradiol correlated positively with response time. Thus, our study demonstrates that individual endogenous estradiol level is a predictor for IAF.

Acknowledgements. The first author was financially supported by the Doctoral College "Imaging the Mind" by the Austrian Science Fund (FWF-W1233).

Laughing rats are optimistic

Rafal Rygula, Helena Pluta¹, Piotr Popik¹

¹Institute of Pharmacology Polish Academy of Sciences, Behavioral Neurobiology and Drug Development, 12 Smetna Street, 31-343 Krakow, Poland

Our decisions are often biased by emotions. For instance, people in negative emotional states are pessimistic while those experiencing positive emotions are often more optimistic. Several recent studies have investigated those affect-contingent judgement biases in animal models. The animals, however, cannot self-report; therefore, the valence of their emotions, to date, could only be assumed. Here we present the results of an experiment where the affect-contingent judgement bias has been produced by objectively measured positive emotions. To directly link affective state with cognitive bias, we combined two innovative but validated behavioural techniques for the induction, objective measurement and evaluation of cognitive outputs of emotions in animals. To induce positive emotions, the animals were subjected to playful, experimenter-administered, manual, somatosensory stimulation-tickling. To directly index positive affect in rats, we have measured the tickling-induced 50-kHz ultrasonic vocalisation (rat laughter) that has been postulated to be a correlate of human joy. For the evaluation of the affect-contingent cognitive bias, we have used the ambiguous-cue interpretation paradigm, where animals must decide about the valence of ambiguous stimuli. Our findings indicate that tickling induced positive emotions which are directly indexed in rats by laughter, can make animals more optimistic. We demonstrate for the first time a link between the directly measured positive affective state and decision making under uncertainty in an animal model. We also introduce innovative tandem-approach for studying emotional-cognitive interplay in animals, which may be of great value for understanding the cognitive changes associated with mood disorders.

Acknowledgement

This work was supported by the Foundation for Polish Science "Homing Plus" Programme co-financed by the European Regional Development Fund (Innovative Economy Operational Programme 2007-2013) and the statutory funds of the Institute of Pharmacology Polish Academy of Sciences.

Rhesus monkeys can switch volitionally between distinct call types

Natalja Gavrilov, Steffen R. Hage¹, Andreas Nieder¹

¹University of Tübingen, Institute for Neurobiology, Auf der Morgenstelle 28, 72076 Tübingen, Germany

Speech is one of the key distinguishing features that defines us as human and allows us sophisticated audio-vocal communication. A necessary criterion for language production is volition. Speech sounds that we learn throughout our lives can be uttered or withheld on command. Vocal utterances of non-human primates, our closest phylogenetic relatives, however, are genetically determined and generally assumed to be highly affective and tightly bound to specific motivational states. Whether nonhuman primates can decouple their vocalizations from the accompanied motivational state and instrumentalize them in a goal-directed way remains a matter of debate for decades. So far, all attempts trying to show that non-human primates are able to volitionally control their vocalizations failed, were of anecdotal evidence, suffered from severe methodological shortcomings or confirmed that nonhuman primates produce adequate motivationally based responses to hedonistic stimuli rather than demonstrating the capability to volitionally vocalize on command.

We trained a rhesus monkey to perform a computer-controlled 'go/nogo' detection task by using its vocalization as a response. The monkey initiated the trials by grasping a bar. A visual cue, the 'nogo'-signal (white square, diameter: 0.5 ° of visual angle) appeared for a randomized time of 1 to 5s. During this period the monkey had to withhold the vocalization. Following the 'nogo' signal (e.g. blue square, 3000 ms duration) in 80% of the trials, the animal was required to utter a 'grunt' vocalization to receive a fluid reward. In contrast, the monkey was forced to emit a 'coo' call whenever another visual cue (e.g. red square) was presented. The two different 'go' stimuli always randomized with equal probability. The obtained data were analyzed by applying signal detection theory (SDT). According to this theory, 'go'-trial in which the monkey uttered the appropriate call type were defined as 'Hits', whereas 'go' trials in which the animal emitted the wrong vocalization were defined as 'False Alarms'. As a measure of sensitivity, the d' -values were calculated.

Our results show that the monkey was able to instrumentalize its vocal utterances in response of arbitrary visual cues. Importantly, the monkey was able to respond with different vocalizations in response of different arbitrary visual cues to receive a reward. Throughout the experimental sessions, the mean values were high for 'hit' rates (grunt: 22.16 ± 7.85 ; coo: 42.2 ± 11.05) and low for 'false alarm' rates (grunt: 0.6 ± 1.05 ; coo: 2.55 ± 1.95) for both vocalization types. The obtained 'hit' and 'false alarm' rates led to d' -prime values of 1.97 and 1.8, for grunts and coos respectively. This indicates that it was able to decouple its vocal output from a motivational state.

Our results show that monkeys are able to volitionally initiate their vocal output. This capacity might constitute an obligate communication precursor for the evolution of speech in the primate lineage. The present study paves the way to study evolutionary aspects of human speech control in a nonhuman primate.

Acquisition vs. Memorization Trade-offs in Comparative Visual Search

Gregor Hardiess, Noemi D Martin¹, Aylin Sarikaya¹, Hanspeter A Mallot¹

¹University of Tübingen, Neurobiology, Cognitive Neuroscience, Auf der Morgenstelle 28, 72076 Tübingen, Germany

In visual working memory (WM) the capacity as well as the temporal range in which information can be stored is surprisingly small. This has been impressively shown by research about change blindness. Hence, in everyday tasks executive processes are applied in order to assign adequate capacity to the process of memorization. On the other hand, environmental information must be gathered by the sensors to enable the process of acquisition. In the view of optimizing visual task performance (with respect to a set of constraints, such as metabolic energy, time, or memory load) the use of WM (memorization) and gaze or body movements (acquisition) must be balanced based on their costs to maximize efficiency (i.e., trade-off). If costs for memorization and for acquisition change between conditions it was shown that this trade-off is adapted in a robust and stable manner Droll & Hayhoe, 2007 and Hardiess et al., 2011).

In comparative visual search (CVS) subjects compare two almost identical arrays of stimuli with the task to identify possible differences between them (Hardiess et al., 2008). In order to control time available for acquisition and memorization a mask (always covering one stimulus array) was used in a series of new experiments. To perform the comparison this mask must be shifted between the arrays by using the left or right mouse buttons (see figure). In such a task the costs for acquisition can be changed by (i) varying the distance between the arrays or (ii) manipulating the time a subject has to wait before new information of the other array can be gathered. Additionally, the costs for memorization can be changed by (iii) using stimuli differing in their costs for visual processing (e.g., color vs. simple shape, simple shape vs. complex objects; see figure) or by (iv) enabling/disabling verbal rehearsal. In a series of recent experiments, we present data about the trade-off adaptation concerning all these experimental manipulations. Here, processing time, i.e., time subjects spend within one array to process the stimuli, was used as measure for memorization and number of mask (left-right) shifts was associated with the reliance on the process of acquisition. The overall results show a robust, significant, but differing degree in trade-off adaptation with respect to the manipulated task constraints.

1. Droll, J.A. & Hayhoe, M.M. (2007). Trade-offs between gaze and working memory use. *J Exp Psychol Hum Percept Perform*, 33(6): 1352–1365.
2. Hardiess, G., Gillner, S., & Mallot, H. A. (2008). Head and eye movements and the role of memory limitations in a visual search paradigm. *J Vis*, 8(1): 1–13.
3. Hardiess, G., Basten, K., & Mallot, H. A. (2011). Acquisition vs. memorization trade-offs are modulated by walking distance and pattern complexity in a large-scale copying paradigm. *PLoS ONE*, 6(4), e18494.

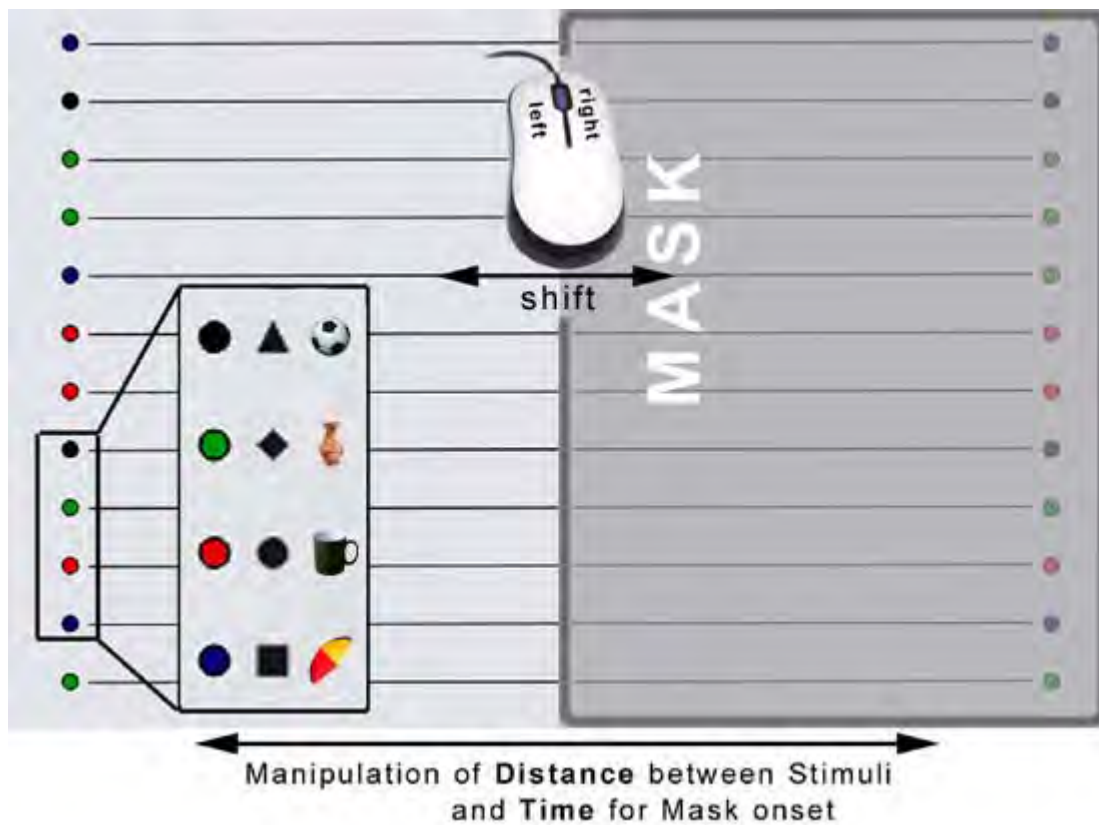

Visual Search in Barn Owls

Julius Orłowski, Petra Nikolay¹, Ohad Ben-Shahar², Hermann Wagner¹

¹RWTH Aachen, Institute for Biology II, Mies van der Rohe Straße 15, 52074 Aachen, Germany

²Ben-Gurion University, Computer Science Department, 84105 Beer-Sheva, Israel

Mechanisms of visual attention have a long history of research in humans and primates, but whether these mechanisms are universal in all vertebrates remains unclear. We study these processes in barn owls; namely, whether search strategies in simple and complex search tasks are as described in primates. Lacking eye movements, barn owls move their head to fixate visual targets. Thus, gaze can be tracked with a head mounted microcamera, the Owlcam. We analyze the gaze path and fixations of barn owls in an open field setting while the owl investigates a pattern with target placed on the ground. First, owls are confronted with single feature patterns containing one odd target among several identical distracters in different set sizes. The features are either differently oriented bars or grey discs of differing intensity. Then we merge these features to a conjunction task; here the odd target is a unique conjunction of orientation and intensity. Initial findings suggest that barn owl search behavior resembles human behavior, as they look more often and prolonged at target items.

Poster Topic

T25: Learning and Memory

- T25-1A** Punishment- versus pain relief-learning in *Drosophila*
Sören Diegelmann, Thomas Niewalda, Mirjam Appel, Jennifer Bergmann, Stephan Preuschoff, Birgit Michels, Ayse Yarali, Bertram Gerber
- T25-2A** Learning to navigate: exploratory orientation flights of young honeybees
Jacqueline Degen, Andreas Kirbach, Konstantin Lehmann, Randolph Menzel
- T25-3A** Housing conditions modulate the cognitive performance in transgenic mice overexpressing the schizophrenia susceptibility gene *Tcf4*
Magdalena M. Brzózka, Dorota Badowska, Peter Falkai, Moritz J. Rossner
- T25-4A** Faster Spreading Activation for High Feature Concept Words
Andrea Zauner, Wolfgang Klimesch, Nicole Alexandra Himmelstoß
- T25-5A** Effects of the neuroactive insecticide thiacloprid on the flight behavior of honeybees
Lena Faust, Johannes Hahn, Bernd Grünewald
- T25-6A** Phase change in Desert Locusts is associated with short- and long-term differences in the distribution of serotonin in the CNS
Swidbert Roger Ott, Stephen Mark Rogers
- T25-7A** Associating neuronal activity with vocal communication in free moving members of a social group of zebra finches
Andries Ter Maat, Lisa Trost, Rene F Jansen, Manfred Gahr
- T25-8A** Enhanced performance in a complex auditory relearning task by controlled enzymatic modulation of the extracellular matrix in auditory cortex
Hartmut Niekisch, Matthias Deliano, Laura L. Castiblanco, Renato Frischknecht, Max Happel
- T25-9A** Effects of neonicotinoid insecticides on motor and neuronal activity in the honeybee
Martina Triltsch, Johannes Fischer, Konstantin Kabat vel Job, Bernd Grünewald
- T25-10A** Quantification of phosphorylated CREB in inner compact Kenyon cells in the honey bee brain
Katrin B. Gehring, Karin Heufelder, Dorothea Eisenhardt
- T25-11A** Circuit mechanisms of associative fear learning in auditory cortex
Johannes Jakob Letzkus, Steffen Wolff, Elisabeth Meyer, Philip Tovote, Julien Courtin, Cyril Herry, Julia Luedke, Andreas Luthi

- T25-12A** Octopamine and tyramine regulate the sucrose sensitivity in the honeybee (*Apis mellifera*) depending on the animals feeding state.
Christina Buckemüller, Richard Zeumer, Oliver Siehler, Isabel Groß, Dorothea Eisenhardt
- T25-13A** In search of neural correlates of decisions in honey bees
Hanna Zwaka, Randolph Menzel
- T25-14A** Retracted
- T25-15A** 'Cognitive enhancement' in *Drosophila* larvae?
Birgit Michels, Maria Pakendorf, Kathrin Franke, Ludger Wessjohann, Oleh Lushchak, Dushyant Mishra, Bertram Gerber
- T25-1B** The reward magnitude in conditioning of the honey bee's proboscis extension response affects memory formation
Kathrin Marter, Lars Bothe, Laura Morgenstern, Carmen Lewa, Dorothea Eisenhardt
- T25-2B** A Network for the Representation of Object Positions in the Central Complex of *Drosophila*
Hannah Marie Wagner, Burkhard Poeck, Roland Strauss
- T25-3B** Rat navigation with visual and acoustic cues in Virtual Reality on a Servo Ball
Ursula Kaupert, York Winter
- T25-4B** Acoustically guided way-finding in humans: the role of gender and sightedness
Daniel Schmidtke, Sarah Galinski, Karl-Heinz Esser
- T25-5B** Synaptic dynamics in the auditory cortex during learning and memory recall
Kaja Moczulska, Manuel Peter, Juliane Tinter, Simon Rumpel
- T25-6B** Spatial Orientation of *Apis mellifera* in a LED-Environment
Sören Miehe, Randolph Menzel
- T25-7B** The potential function of CaMKII in long-term memory in the honeybee
Christina Scholl, Wolfgang Rössler
- T25-8B** Melatonin dependent changes in Birdsong - measuring changes in brain activity of freely behaving zebra finches
Susanne Seltmann, Lisa Trost, Andries TerMaat, Sebastien Deregnacourt, Manfred Gahr
- T25-9B** Calling behaviour of Zebra Finches (*Taeniopygia guttata*) forced pairs and activation pattern of a pallial song nucleus during unlearned vocalizations.
Pietro Bruno DAmelio, Lisa Trost, Andries ter Maat
- T25-10B** A laboratory test of spatial recognition in solitary and social bees
Nanxiang Jin, Randolph Menzel
- T25-11B** Subcellular distribution of Ependymins and their binding Partners
Roman Göthe, Rupert Schmidt

- T25-12B** Impact of chronic and acute BDNF deficiency on fear learning and fear extinction
Thomas Endres, Volkmar Lessmann
- T25-13B** Modelling the interaction of synaptic and structural plasticity
Michael Fauth, Christian Tetzlaff, Florentin Wörgötter
- T25-14B** The role of microRNAs in learning and memory the honeybee brain
Julia Rennertz, Uli Müller
- T25-15B** Bidirectional acetylation-mediated modulation of memory in the honeybee: search for the targeted genes
Katja Merschbaecher, Uli Mueller
- T25-16B** Enhancement of Olfactory Acuity via Differential Conditioning of Similar Odors
Jonas Barth, Shubham Dipt, Moritz Hermann, Thomas Riemensperger, André Fiala
- T25-1C** Developmental changes in lateral amygdala inhibitory circuits
Daniel Bosch, Ingrid Ehrlich
- T25-2C** Effects of neonicotinoid insecticides on honeybee homing flight behavior using harmonic radar tracking
Johannes Fischer, Teresa Müller, Anne-Kathrin Spatz, Bernd Grünwald, Randolph Menzel
- T25-3C** The sequence of stimulus presentations during conditioning is critical for memory formation and affects the amount of CREB
Johannes Felsenberg, Jenny Aino Plath, Dorothea Eisenhardt
- T25-4C** 5-HTT Genotype Influences Spatial Learning and the Expression of Different Markers of Neuroplasticity
Margherita Maria Lee, Sina Kollert, Magdalena Weidner, Sandra Grauthoff, Rebecca S. Heiming, K.P. Lesch, Norbert Sachser, Lars Lewejohann, Angelika G. Schmitt
- T25-5C** Synaptic proteome changes in mouse brain regions upon auditory discrimination learning
Angela Kolodziej, Thilo Kähne, Karl-Heinz Smalla, Elke Eisenschmidt, Utz Uwe Haus, Robert Weismantel, Siegfried Kropf, Wolfram Wetzels, Frank W Ohl, Tischmeyer Wolfgang, Michael Nau, Eckart D. Gundelfinger
- T25-6C** Mapping of regional brain activity during two-way active avoidance (TWA) behavior using *in vivo* SPECT-imaging in rats.
Anja Mannewitz, Jürgen Goldschmidt, Katharina Braun
- T25-7C** Detection of object-space novelty in the CA1 of freely behaving mice induces LTD which is dependent on NMDA and mGlu5 receptor activation
Jeremy Goh, Denise Manahan-Vaughan
- T25-8C** APIS – a novel system for automatic conditioning of honey bees
Nicholas Hagen Kirkerud, David Gustav, Henja-Niniane Wehmann, C. Giovanni Galizia

- T25-9C** Age-dependent impact of avoidance pretraining on adult learning: functional imaging in freely behaving mice
Almuth Spröwitz, Anett Riedel, Jörg Bock, Katharina Braun
- T25-10C** A walking simulator for studying aversive classical and operant conditioning in honeybees
Florian BASTIN, Andreas S. Brandstaetter, Jean-Christophe Sandoz
- T25-11C** Ionic current modulations of honeybee antennal lobe and mushroom body neurons
Sophie Himmelreich, Bernd Grünwald
- T25-12C** Physiological mechanisms of sensory augmentation assessed by fMRI
Johannes Keyser, Susan Wache, Maria Schmitz, Sebastian Fleck, Sabine U. König, Robert Muil, Saskia K. Nagel, Frank Schumann, Thomas Wolbers, Christian Büchel, Peter König
- T25-13C** Effects of glutamate in intra- and extracellular recordings from mushroom body extrinsic neurons in the honey bee
Ruth Bartels, Stefan Voigt, Randolph Menzel
- T25-14C** Heterogenous populations of amygdala medial paracapsular intercalated cells receive presynaptically - modulated sensory inputs
Douglas Asede, Daniel Bosch, Francesco Ferraguti, Ingrid Ehrlich
- T25-15C** Pattern separation in the human hippocampus
David Berron, Hartmut Schütze, Emrah Düzel
- T25-16C** Testing *Drosophila* learning and memory mutants with and without methylphenidate treatment in Buridan's paradigm
Yasmine Jennifer Graf, Bjoern Brembs
- T25-1D** Characterization of mPFC inputs to principal neurons and interneurons in the basolateral amygdala
Cora Hübner, Daniel Bosch, Andreas Lüthi, Ingrid Ehrlich
- T25-2D** The characterization of the different SAP47 isoforms
Jörg Kleber, Timo Saumweber, Sören Diegelmann, Bertram Gerber
- T25-3D** Towards the Biochemical Components of the Visual Orientation Memory in *Drosophila*
Sara Kuntz, Burkhard Poeck, Roland Strauss
- T25-4D** High-voltage activated Ca²⁺ channels in septohippocampal thetagensis
Anna Papazoglou, Magdalena, Elisabeth Siwek, Christina Henseler, Ralf Müller, Karl Broich, Marco Weiergräber
- T25-5D** Thermo-genetic induction of a memory trace in subsets of *Drosophila* mushroom body Kenyon cells
Thomas Dieter Riemensperger, David Vasmer, Atefeh Pooryasin, Silke Dempewolf, Hendrik Urbanke, André Fiala
- T25-6D** Single-neuron photoactivation via recombinase-mediated cell-specific expression of

Channelrhodopsin-2, to analyze habituation in sensory neuronal circuits
Cornelia Schmitt, Jana Liewald, Sebastian Wabnig, Alexander Gottschalk

- T25-7D** Population clock models and delayed temporal memory: An information theoretic approach
Sakyasingha Dasgupta, Florentin Wörgötter, Poramate Manoonpong
- T25-8D** Learned Helplessness in *Drosophila*
Zhengong Yang, Reinhard Wolf, Martin Heisenberg
- T25-9D** Operant conditioning of *Drosophila* in the Shockbox
Sophie Johanna Batsching, Reinhard Wolf, Martin Heisenberg
- T25-10D** Policy learning in self-organising spiking networks through neuromodulation of synaptic transmission
Simon M. Vogt, Ulrich G. Hofmann
- T25-11D** Characterization of singing and listening associated firing patterns of six different neuron types in basal ganglia song nucleus Area X during song development
Lisa Kolb, Constance Scharff, Richard Hahnloser
- T25-12D** Deciphering the architecture of the insect mushroom body to understand its role in olfactory learning and memory
Gérard Lebouille
- T25-13D** Transient action of RNA-polymerase II inhibitor on learning in honeybees
Aline Loehfelm, Katja Merschbaecher, Uli Mueller
- T25-14D** Pathway specific neuronal dynamics in the entorhinal-hippocampal circuit
Gerrit Schwesig, Anton Sirota
- T25-15D** Glucose, AMP-dependent protein kinase and learning in honeybees
Marie-Anne Croyé, Kathy Rether, Uli Mueller
- T25-16D** Search for the up-stream regulators of histone deacetylases in honeybees
Jennifer Folz, Uli Mueller
- T25-17D** Characterization of a functional RhoSAP/Rich2 – ProSAP2/Shank3 interaction using a novel Rich2 transgenic mouse model
Claus Matti Eckert, Jürgen Bockmann, Tobias M. Boeckers, Andreas M. Grabrucker

Punishment- versus pain relief-learning in *Drosophila*

Sören Diegelmann, Thomas Niewalda¹, Mirjam Appel², Jennifer Bergmann¹, Stephan Preuschoff¹, Birgit Michels¹, Ayse Yarali², Bertram Gerber¹

¹Leibniz Institute for Neurobiology, Genetics of Learning and Memory, Magdeburg, Germany

²Max-Planck Institute of Neurobiology, Martinsried, Germany

Painful events shape our behaviour in two ways: Stimuli associated with pain onset subsequently support learned avoidance, as they predict punishment. In turn, stimuli associated with pain offset signal relief and later on support learned approach. The balance between such punishment- and relief-learning is crucial for the adaptive organization of behaviour in the aftermath of painful events. If not sufficiently curbed, this adaptive learning process may lead to maladaptive behaviour and undesired psychological states such as anxiety, panic or stress. Therefore any process that can counteract such avoidance behaviour may be of value.

Given the genetic tools available and the homology of many genes between flies and man, the fruit fly *Drosophila melanogaster* provides a suitable model to investigate the basic principles underlying punishment- as well as pain relief-learning. Our aim is to understand how a given reinforcer can lead to memory traces with opposite behavioural valence. Using the olfactory learning paradigm in *Drosophila* we aim to understand the molecular and cellular mechanisms underlying behaviourally opposite memory traces regarding the onset versus offset of an electric shock.

We focused on the evolutionary conserved presynaptic protein Synapsin, a vesicle-associated protein, regulating the recruitment of vesicles from the reserve pool to the actual release sites via phosphorylation of various residues inside the protein. Flies lacking Synapsin expression are impaired in both punishment and pain-relief learning, whereas avoidance of shock and of the odours is not affected. A local rescue of Synapsin expression only in the mushroom bodies of the fly is sufficient to restore both memory traces. To validate the role of Synapsin phosphorylation we generated mutant transgenes for PKA target sites. Comparing both kinds of learning we found that punishment learning requires the PKA sites, whereas pain-relief learning seems to be independent of them. In a memory decay study we also compared the temporal decay and the sensitivity for retrograde amnesia. Whereas pain-relief memory is completely lost 24h after training, punishment memory is still detectable. Amnesia erases pain-relief memory, but leaves a third of punishment memory scores intact.

These findings suggest common but also differential bases for punishment and pain-relief learning, thereby offering a perspective for separately interfering with either of them in case the balance between them is distorted.

Learning to navigate: exploratory orientation flights of young honeybees

Jacqueline Degen, Andreas Kirbach¹, Konstantin Lehmann¹, Randolph Menzel^{1,2}

¹Freie Universität Berlin, Neurobiology, Königin-Luise-Str. 28-30, 14195 Berlin, Germany

²Bernstein Center for Computational Neuroscience (BCCN), Berlin, Germany

Honeybees (*Apis mellifera*) perform exploratory orientation flights before they start foraging in order to learn how to return safely to their hive. After inspecting the hive and the nearby environment by turn-round-and-look-back they fly straight away exploring more distant parts of the surrounding environment. We analysed the pattern of the first four consecutive orientation flights applying the harmonic radar technique for tracking the complete flight paths of individually marked bees. A total of 251 orientation flights of 159 bees were recorded. Usually bees explore only one sector of the surrounding during one single orientation flight but some bees investigate up to three different sectors. The first orientation flight may lead the bees into any direction around the hive although there is a bias towards a direction straight out of the hive entrance. Flight duration, maximum distance, area covered during the flight and flight speed do not change significantly during the first four orientation flights. During consecutive orientation flights bees usually explore different sectors around the hive but some bees deviate from this pattern. The overlapping area of an orientation flight with the united areas of all previous flights increases significantly from the second to the third orientation flight. About 60% of the area explored during the third and fourth orientation flight were previously not explored. We recorded the complete orientation phase until the first foraging flight of seven bees. None of these bees explored the whole surrounding of the hive and the first foraging flight from about half of these bees led into a sector they did not explore before. We conclude that bees (1) apply a rather stereotypical exploration pattern during the first four orientation flights leading them to different sectors around the hive and (2) learn sufficient about the sun compass and the environment allowing them to start foraging in an area they did not explore before.

Housing conditions modulate the cognitive performance in transgenic mice overexpressing the schizophrenia susceptibility gene **Tcf4**

Magdalena M. Brzózka, Dorota Badowska^{2,3}, Peter Falkai¹, Moritz J. Rossner^{1,4}

¹Department of Psychiatry and Psychotherapy, Ludwig-Maximilian University, Munich, Germany

²Max-Planck-Institute of Experimental Medicine, Göttingen, Germany

³contributed equally

⁴corresponding author

The basic helix-loop-helix (bHLH) transcription factor TCF4 was confirmed in the combined analysis of several large genome-wide association studies (GWAS) as one of the most significant schizophrenia (SZ) susceptibility genes [Stefansson et al., 2009; Li et al., 2012; Steinberg et al., 2011; Ripke et al., 2011]. TCF4 influences verbal learning and memory in humans [Lennertz et al., 2012] and modulates sensorimotor gating in SZ patients [Quednow et al., 2011]. We showed recently that transgenic mice overexpressing Tcf4 in forebrain (Tcf4tg) display profound deficits in fear memory and sensorimotor gating [Brzózka et al., 2010]. Environmental factors interacting with genetic vulnerability (G x E interactions) play one of the pivotal roles in development of schizophrenia [Myin-Germeys and van Os, 2007] and physical exercise can counteract some symptoms of disease in patients [Pajonk et al., 2010]. We investigated the influence of different environmental conditions on the behavior and cognitive performance of Tcf4tg mice by exposing 4 weeks old animals for 4 weeks to single cage housing (SH) or to group housing in enriched environment (EE). In SH, animals were housed under poor conditions without any enrichment. In contrast, EE cages contained two separate compartments: the first with one-way entrance and one-way exit for drinking/feeding, and the second compartment with tubes and a running wheel enabling physical exercise. Animals underwent a profound analysis addressing basic behavior and cognitive performance.

Different housing conditions altered anxiety and curiosity behavior of Tcf4tg mice in open field and hole board. This contrasts with the phenotype of these mice upon standard group housing [Brzózka et al., 2010]. Housing in EE rescued the cognitive impairment of recent and remote memory in Tcf4tg mice assessed in fear conditioning paradigm. Moreover, SH under poor environment worsened the cognitive performance of transgenic animals in water maze. Poor performance of SH Tcf4tg mice in the reversal water maze task and in delay matching to place paradigm indicates impairment of flexibility learning which may be of particular relevance for SZ [Cridler, 1997].

In the present study, we demonstrated that SH (isolation stress) increases whereas housing in EE (combination of social support with physical exercise) rescues the cognitive impairment of Tcf4tg mice. We provided evidence that the manifestation of the phenotype of Tcf4tg mice depends strongly on environmental factors. This substantiates the importance of GxE interactions in the manifestation of schizophrenic phenotypes. The observed phenotype of Tcf4tg mice may resemble the situation in patients where symptoms can be elicited by the “second hit” (social stress) [Myin-Germeys and van Os, 2007] and can be ameliorated by social support or physiotherapy [Pajonk et al., 2010].

Faster Spreading Activation for High Feature Concept Words

Andrea Zauner, Wolfgang Klimesch¹, Nicole Alexandra Himmelstoß¹

¹University of Salzburg, Physiological Psychology, Hellbrunnerstrasse 34, 5020 Salzburg, Austria

According to the connectivity model for semantic processing proposed by Wolfgang Klimesch about 25 years ago (1987) a concept word is connected with its features and all nodes are interconnected to each other in order to receive indirect activation. As a consequence the more features the stronger the indirect activation what speeds up reaction time. Electrophysiological alpha oscillations are related to semantic processing, whereby ongoing oscillations are modulating evoked activity in order to control early processing. Studies support that the P1 component is partly generated by alpha and provides early access to memory traces by regulating the signal-to-noise ratio. Accordingly, we propose faster spreading activation in terms of faster P1-traveling from leading to trailing positions in a semantic judgment task for high feature concept words compared to low feature concept words. High feature and low feature concept words were selected from McRae's semantic feature production norms (2005). Participants (n= 37, 19 female) made living/non-living judgments while EEG was recorded. Behavioral we found faster reaction times for living words and for high feature concept words. Women showed faster reaction times compared to men but the group effect was not significant. Inspection of the P1 component (8 - 12 Hz filtered data) in posterior areas revealed spreading activation from bilateral to central sites in most of the cases. We calculated the individual differences between leading and trailing electrode in millisecond as a measurement for traveling and found significant faster traveling for high feature concept words compared to low feature concept words for the living domain only. Regarding amplitude analyses showed a decrease from leading to trailing electrode in the women sample only, whereby men had lower amplitudes in general. Moreover latency and amplitude, in terms of differences between leading and trailing, were significantly correlated for women, suggesting the stronger the decrease in amplitude the faster the traveling process from leading to trailing sites. Finally, we calculated phase-locking and found an interesting effect for non-living words showing higher PLI. In conclusion the results support the connectivity model. High feature concept words showed faster P1-traveling from leading to trailing sites, in other words a faster spreading activation process emerges in a more interconnected semantic network. The fact that non-living words showed no such traveling effects can be explained by the no-response mode. Non-living words are not searched, they had to be rejected. That needs time what is supported by the slower reaction times found for non-living words. Moreover, setting a threshold level for rejection is time locked, what enables phase-locking. Finally, only women showed a decrease in amplitude from leading to trailing sites and a correlation between P1 latency and amplitude. That can be interpreted as a decrease in inhibition what in turn leads to faster spreading activation in a semantic network.



Effects of the neuroactive insecticide thiacloprid on the flight behavior of honeybees

Lena Faust, Johannes Hahn¹, Bernd Grünewald¹

¹Goethe Universität Frankfurt (Main), Zellbiologie und Neurowissenschaft, Max-von-Laue-Straße 13, 60438 Frankfurt (Main), Germany

Honeybees get into contact with insecticides while collecting pollen and nectar. One of the insecticides commonly used in the field is the neonicotinoid thiacloprid that is applied e.g. in oilseed rape during florescence. Thiacloprid is known for its relatively low toxicity to honeybees, though sublethal effects are not studied very well yet.

Neonicotinoids act as agonists of the acetylcholine receptor of insect and thus affect certain behaviors. Here we examine the influence of sublethal doses of thiacloprid on the flight behavior of honeybees under field conditions by using the RFID microchip technique.

For our studies about the effects of chronic uptake of thiacloprid by honeybee larvae, we simulated the consumption of thiacloprid via nectar by feeding bees with sugar syrup containing 5000 ppb thiacloprid in the hive, respectively with pure sugar syrup for control under flight tents.

After pupation of the larvae, the tents were removed and the bees were free to forage for pollen and nectar in their environment. Two days before eclosion the brood combs were transferred into an incubator and stored at 34.5° C. After eclosion, each bee was labeled with a RFID microchip on the thorax. The use of these microchips allows recording every bee that leaves or returns to the bee hive by passaging through scanners that are positioned directly in front of the hive. Data were stored with indication of direction and time. To estimate the date of death for each marked bee, the day of the last registration was noted.

By analyzing the live span of each bee and the age on which it started for its first flight out of the hive, we observed obvious differences. Bees that were fed with sugar syrup containing thiacloprid as larvae started highly significantly later for their first flight (median 10 days later), and they lived significantly longer than bees fed with pure sugar syrup.

In a second study, we wanted to investigate whether and how an acute uptake of 250 ng thiacloprid per bee may have an impact on the homing flight behavior of honeybees.

For this, adult bees were captured at the hive entrance when flying out, chipped with an RFID microchip each and brought to different places with distances to the bee hive between 200 and 900 meters. The bees were fed with 10µl of diluted honey (1:1 diluted with water) either with thiacloprid added or without and then were allowed to collect pure diluted honey ad libitum. Directly following they were released and the time they required to fly back to the hive was evaluated.

There were no significant differences between the duration of homing flight between the groups, but there were higher bee losses of the thiacloprid-fed group.

According to the findings of our study, sublethal doses of the insecticide thiacloprid appear to delay the behavioral development of honey bees and may interfere with their orientation capacities.

Phase change in Desert Locusts is associated with short- and long-term differences in the distribution of serotonin in the CNS

Swidbert Roger Ott, Stephen Mark Rogers¹

¹University of Cambridge, Department of Zoology, Downing Street, CB2 3EJ Cambridge, United Kingdom

Serotonin (5HT) is implicated in the regulation of a wide range of behavioural processes, including social interaction. In Desert Locusts (*Schistocerca gregaria*), 5HT induces a rapid behavioural change from a *solitarious phase*, in which locusts avoid each other, towards a more active *gregarious phase*, in which locusts form coherent groups that may ultimately culminate in swarm formation. In solitarious locusts, appropriate stimuli from other locusts produce a surge of 5HT in the thoracic ganglia but once gregarization is established, amounts decline rapidly and fully established gregarious locusts have less 5HT in their CNS than do solitarious locusts.

Methods.—We used immunofluorescence (IF) staining in the thoracic ganglia to compare the expression of 5HT between locusts receiving gregarizing stimuli and the fully established phases. We present results from new regression-based approaches to the quantitative analysis of IF in somata and in the neuropile that separate random differences in global brightness from treatment-associated local differences in relative IF between groups. We analysed IF intensity in the somata of all serotonergic neurones in the three ganglia (*pro*-, *meso*-, and *meta*-thoracic ganglion). Non-rigid image registration of the 5HT distribution in the neuropiles of individual ganglia onto a common shape- and intensity-averaged standard permitted voxel-wise regression analysis of group differences in relative local neuropile brightness.

Results.—In each of the thoracic ganglia, somata just ventral and lateral to the anterior connectives were relatively more intensely stained in locusts that had received multiple gregarizing stimuli: in *pro* and *meso* they occur as clusters of 11–13 small somata, but in *meta* a single larger soma occurs in this location. A different class of somata found across all three ganglia showed increased IF in response to exposure to the sight and smell of ~500 other locusts. A further class of neurons in *meso* and *meta* were less intensely stained in long-term gregarious compared with long-term solitarious locusts, but were unaffected by any of the gregarising treatments. The distribution of 5HT in the neuropiles showed wide-ranging differences between fully established phases, with gregarious locusts showing increased expression particularly in the projection centres of mechanosensory afferents (Figure, A), and solitarious locusts showing increased expression in domains along the lateral edges of the neuropil (Figure, B). By contrast, acute crowding caused much more restricted changes that, notably, include an increase in the dorsal neuropile of *meta*, the putative output region of the neurone that up-regulates 5HT upon gregarising input. These data suggest that the serotonergic neurons that are responsible for the transition to gregarious behaviour and those that produce altered regulation of behaviours in the fully established phases constitute anatomically distinct subclasses.

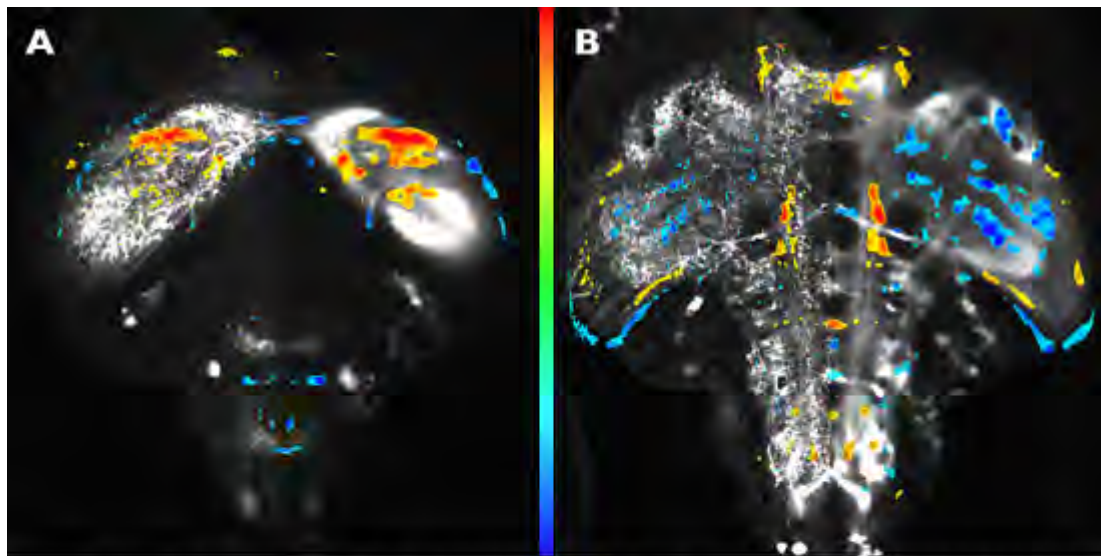

Long-term phase differences in the distribution of 5HT in the neuropile of the metathoracic ganglion. *Greyscale images* in left half of ganglia show a single preparation, right half the average distribution in standard ganglion. *Statistical maps* in left half of ganglia are based on original data, 12.5% FDR threshold; right half after Gaussian blur ($\sigma = 5 \mu\text{m}$), 5% FDR threshold. *Blue*: more in solitary; *red*: more in gregarious; *scale range*: $t = \pm 6$. Horizontal slices. **(A)** Ventral association centre (VAC) of metathoracic neuromere; gregarious locusts show increased 5HT in sub-regions within VAC that is attributable to the terminals of a subset of sensory afferent neurones; expression in interneuronally derived meshworks surrounding VAC is stronger in solitary locusts. **(B)** Mid-plane of ganglion: solitary locusts have higher 5HT expression in discrete domains along the lateral edge of the neuropile that derives in part from prominent commissural interneurons.

Associating neuronal activity with vocal communication in free moving members of a social group of zebra finches

Andries Ter Maat, Lisa Trost¹, Rene F Jansen², Manfred Gahr¹

¹Max-Planck-Institute for Ornithology, Behavioural Neurobiology, Eberhard-Gwinner-Str. 6a, 82319 Seewiesen, Germany

²Vrije Universiteit Amsterdam, De Boelelaan 1087, 1061 HV Amsterdam, The Netherlands

Zebra finches are gregarious birds that vocalize at high rates. These vocalizations include various calls as well as a highly stereotypical song. Previous work by others has shown that the temporal structure of the song is affected by the social setting in which the song is produced, i.e. there is a difference between songs directed at a (potential) partner and songs sung in other situations. We studied the effect of group living on the patterns of mutual calling and song production. In the brain of the zebra finch a group of nuclei is devoted to the production and learning of songs. One of these nuclei (robust nucleus of the arcopallium; RA) is a premotor nucleus that organizes the motor output of the brainstem nuclei innervating the syrinx. Lesion studies suggest that RA is not involved in the production of unlearned vocalizations such as tet and stack calls as well as the female contact call of zebra finches. Learned vocalizations, song and male distance calls, require an intact RA (Simpson and Vicario, *J Neurosci* 10, 1541-1556, 1990). To explore the possible influence of the social environment on the production of song and calls, as well as its effect on neuronal activity, we housed three groups consisting of two pairs each in three aviaries. Each bird was equipped with a wireless microphone. The two males in each group had a tungsten electrode implanted in RA, which was connected to a high impedance amplifier stage of a wireless telemetric device (Schregardus et al., *J Neurosci Meth* 155, 62-71, 2006) This enabled us to associate the vocalizations of the two males and the two females with each other, as well as with the neuronal RA activity in both males.

Vocalizations were divided up into syllables and calls that were captured and time-stamped. Neuronal activity was digitized using a peak detector and stored as a 64 point vector. The spikes were then sorted using a k-means algorithm. The vocalizations were also sorted and their times of occurrence recorded. We studied the temporal correlation of electrical and vocal events of these group-living animals and found a close temporal association between the calls of pair bonded birds. Premotor activity from the "song nucleus" RA could be recorded that was associated with these calls in freely behaving zebra finches. Moreover, we demonstrated that electrical activity preceding various types of call, song and distance calls, could be shown by one and the same neuron.

Enhanced performance in a complex auditory relearning task by controlled enzymatic modulation of the extracellular matrix in auditory cortex

Hartmut Niekisch, Matthias Deliano¹, Laura L. Castiblanco¹, Renato Frischknecht², Max Happel¹

¹Leibniz-Institute for Neurobiology, Systems Physiology of Learning, Brenneckestr. 6, 39118 Magdeburg, Germany

²Leibniz-Institute for Neurobiology, Neurobiology and Molecular Biology, Brenneckestr. 6, 39118 Magdeburg, Germany

Processing, storage and retrieval of sensory information is fundamental for perception and learning. Structural and functional stabilization of experience-shaped, established synaptic connections in neuronal networks is an important underlying key mechanism. During development, the change from juvenile to mature brain plasticity coincides with the appearance of the brain's specialized extracellular matrix (ECM), which therefore has been considered to mainly stabilize evolved synaptic networks. Recently, we demonstrated that experimental removal of the ECM alters synaptic short-term plasticity at the level of individual synapses by enhanced synaptic exchange of postsynaptic receptors (Frischknecht et al., 2009; Nat. Neurosci.). Consequently, we hypothesized that ECM-derived modulation of synaptic transmission might also influence adult animal learning behavior.

In this study, we used enzymatic degradation of the ECM within the primary auditory cortex (ACx) of Mongolian gerbils by microinjection of hyaluronidase (HYase) to modulate neuronal plasticity underlying certain forms of cortex-dependent auditory learning. By HYase injections we created short-term windows of enhanced activity-dependent neuroplastic reorganization during specific phases of a complex auditory reversal learning task (Go-NoGo-based discrimination of rising vs. falling frequency-modulated (FM) tones). We found that already established learning capacities would not be erased by removal of the ECM in sensory cortex. However, when the contingency of the initially Go- and NoGo-stimuli were exchanged, re-learning of the new meaning was significantly enhanced by ECM-removal compared to a control group (see Figure). Using quantitative western blotting we further investigated ECM dynamics during learning processes in the adult brain as a potential mechanism to facilitate synaptic remodeling in the adult brain.

Our findings suggest that experimental ECM modulation allow for guided neuroplasticity to effectively enhance complex forms of cortex-dependent learning processes in adult animals without affecting established cortex-based memory function. This highlights a new function of the ECM in sensory cortex as a potential regulatory switch to adjust the balance between stability and plasticity in adult neuronal networks and might also open new directions in applied neuroscience.



Effects of neonicotinoid insecticides on motor and neuronal activity in the honeybee

Martina Triltsch, Johannes Fischer¹, Konstantin Kabat vel Job¹, Bernd Grünewald¹

¹Goethe-Universität Frankfurt am Main, Institut für Zellbiologie und Neurowissenschaften, Max-von-Laue-Str. 13, 60438 Frankfurt am Main, Germany

Neonicotinoid insecticides act as agonists of the insect nicotinic acetylcholine receptor. During foraging flights honeybees come into contacts with the insecticides. We tested the effects of the neonicotinoids, clothianidin, thiacloprid, and imidacloprid, on the motor activity and the nervous system of bees. We show that the substances induce different effects.

In a first approach we monitored the movement of adult honeybee workers in a small walking arena. The arena consisted of a glass petri dish with a diameter of 13.6 cm and a height of 2.2 cm. The walking registration was conducted in the dark under dark red illumination. The movement of the bees was recorded for a period of 3 min before and a few minutes after they were fed individually with 10 μ L of sucrose solution (40% [w/v]) supplemented with clothianidin (0.4 μ M) or thiacloprid (400 μ M). The locomotor activity before and after substance feeding was compared. Clothianidin-treated bees increased the walking speed from an average 2.83 cm/s to 4.98 cm/s as compared to control animals that received only sugar water. By contrast, the walking speed of thiacloprid-treated bees decreased from 4.54 cm/s to 2.45 cm/s.

To analyze the effects of neonicotinoids on muscle activity in more detail we extracellularly recorded spike activity of the muscle M17 before and during application of 1 μ L clothianidin, thiacloprid, or imidacloprid (1 μ M) into the open head capsule. Muscle spikes and proboscis extension reactions were elicited by stimulating the antennae and the proboscis with a toothpick soaked with sucrose solution. We investigated neonicotinoid-induced changes by determining the number of spikes at various intervals after substance application. Application of 1 μ L phosphate-buffered saline was used as a control. Again we observed an increase of activity after clothianidin treatment and a decrease after thiacloprid or imidacloprid applications. Clothianidin (1 μ M) increased the number of muscle spikes as compared to the control group and in some animals even led to tonic spiking in the absence of sucrose stimulation. This significant effect was observed as early as 10 minutes after substance application. By contrast, imidacloprid as well as thiacloprid reduced the spike activity during the whole recording period (1 h) with a significant difference of imidacloprid to the control treatment 30 minutes after application.

Our results indicate distinct effects of the various insecticides on honeybee motor activity. We are currently investigating the effects of insecticides on the nervous system of the honeybee assuming that the observed effect is induced via modulating neuronal cholinergic transmission.

Quantification of phosphorylated CREB in inner compact Kenyon cells in the honey bee brain

Katrin B. Gehring, Karin Heufelder¹, Dorothea Eisenhardt¹

¹Freie Universität Berlin, Neurobiologie, Königin-Luise-Str. 28-30, 14195 Berlin, Germany

The transcription factor CREB (cAMP response element binding protein) is involved in regulation of growth, differentiation, neuronal viability and circadian rhythms. It also plays an essential role in the formation of long term memory (LTM). CREB induces gene expression after being phosphorylated by several kinases. A huge body of work analyzed this CREB phosphorylation but little is known about its role in the honey bee (*Apis mellifera*), a well-known invertebrate model system for learning and memory. Our aim is to characterize *Apis mellifera* CREB and localize CREB dependent processes in the honey bee brain.

We use a monoclonal antibody to investigate the amount and the localization of phosphorylated CREB (pCREB) in fixed bee brain slices and in bee homogenate.

pCREB immunoreactivity (IR) can be observed in a wide range of cell nuclei in the bee brain, among them nuclei of neurons known to be involved in processing sensory information, for example intrinsic mushroom body neurons (Kenyon cells, KCs). One subgroup of KCs, the inner compact KCs (icKCs), are predominantly stained. In contrast to the assumed distribution of pCREB, which, as a transcription factor, is thought to be predominantly located in the nucleus, we also find strong immunoreactivity in axonal and dendritic parts of Kenyon cells.

We first investigated the distribution of pCREB-IR in KCs of bees with different age. We compared one day old bees with more experienced bees and found an age-dependent increase of pCREB levels in the icKCs. Second, we were interested whether the pCREB level in this KC subgroup is altered after classical conditioning. We conditioned 22 days old bees in an appetitive conditioning paradigm and found increased pCREB-IR in the nuclei of the icKCs compared to a control group receiving the same amount of stimuli.

We therefore hypothesize that the icKCs have an increased CREB-dependent transcriptional activity which is age- and learning-dependent.

Circuit mechanisms of associative fear learning in auditory cortex

Johannes Jakob Letzkus, Steffen Wolff¹, Elisabeth Meyer¹, Philip Tovote¹, Julien Courtin², Cyril Herry², Julia Luedke¹, Andreas Luthi¹

¹FMI, Neurobiology, Maulbeerstrasse 66, 4058 Basel, Switzerland

²INSERM U862, Neurocentre Magendie, 146 Rue Léo-Saignat, 33077 Bordeaux, France.

Memory formation is one of the most fundamental brain functions. While synaptic plasticity as the putative cellular mechanism of learning has been studied in great detail, we know much less about how interactions between different types of neurons within local circuits contribute to memory formation. To address this question, we recorded activity in identified neurons in auditory cortex during foot-shocks, which drive formation of associative fear memory when coinciding with tones. Two-photon calcium imaging and targeted patch-clamp recordings in anaesthetized mice showed that foot-shocks strongly excite inhibitory interneurons in layer 1 (L1). Pharmacology and microstimulation suggest this activation to be mediated by basal forebrain cholinergic afferents activating nicotinic acetylcholine receptors (nAChRs) on L1 interneurons. In search for postsynaptic targets of L1 interneurons, we recorded from fast-spiking parvalbumin-positive interneurons in L2/3, which were labeled by a combination of viral and mouse genetic approaches. These neurons display high baseline firing rates, and are strongly inhibited by foot-shocks. This inhibition is likely mediated by L1 interneurons because we observe synaptic contacts between these cells, because the latencies match, and because, like in L1 interneurons, foot-shock responses of fast-spiking interneurons are greatly reduced by nAChR antagonists. Finally, whole-cell recordings from L2/3 pyramidal neurons suggest nAChR-dependent disinhibition during foot-shocks, generating greatly enhanced responses when tones are paired with foot-shocks. In conclusion, we have defined a neocortical microcircuit causing disinhibition of pyramidal neurons, thereby enhancing sensory responses and potentially gating activity-dependent synaptic plasticity either locally or in downstream target areas. Intriguingly, counteracting the observed inhibition of auditory cortex fast-spiking interneurons exclusively during and after the foot-shock by optogenetic means leads to almost complete block of fear memory formation in behaving mice, suggesting that this microcircuit is necessary for associative learning.

Octopamine and tyramine regulate the sucrose sensitivity in the honeybee (*Apis mellifera*) depending on the animals feeding state.

Christina Buckemüller, Richard Zeumer¹, Oliver Siehler¹, Isabel Groß¹, Dorothea Eisenhardt¹

¹Freie Universität Berlin, Institut für Neurobiologie, Königin-Luise-Str. 28/30, 14195 Berlin, Germany

Biogenic amines play an important role as neurotransmitters, neuromodulators and neurohormones in invertebrates. They are important for different behaviors, e.g. aggression, egg-laying and walking.

Honeybees are highly responsive to sugar solutions. This sensitivity differs between bees and can be altered by biogenic amines. We want to know the dependency of the bee's sucrose sensitivity on the feeding state and the precise role of the biogenic amines octopamine and tyramine.

In our experiments we used epinastine, which has been demonstrated to antagonize octopamine receptors in honeybees (Roeder et al. 1998, European Journal of Pharmacology 349 (2-3), p. 171-177). Beggs *et al.* (2011) showed that epinastine not only inhibits the AmOA1 but also the AmDOP2 receptors. Therefore, epinastine is not only an octopamine antagonist. Mustard *et al.* (2003) showed that fluphenazine is a strong inhibitor for AmDOP2. Because of these findings experiments were also conducted with the AmDOP2 receptor antagonist fluphenazine to determine whether octopamine or dopamine is involved. As a third experiment we used the tyramine receptor antagonist yohimbine. In the synthesis pathway of octopamine, the enzyme tyramine-beta-hydroxylase transforms tyramine to octopamine. Thus experiments with yohimbine were performed. We first determined the median lethal dose (LD 50) of systemically injected epinastine to find out about the appropriate epinastine concentration to work with.

Following this analysis we studied the impact of octopamine and tyramine on the PER. First we asked if one of the antagonists interferes with the PER depending on the concentration of sucrose used to elicit the response. Three different concentrations of sucrose were used to elicit the PER and the impact of systemically injected epinastine on the PER rate was tested. Then we asked if one of the antagonists affects the animals' motivation to elicit their proboscis. We compared hungry and satiated bees that were injected with epinastine, fluphenazine and yohimbine.

Our experiments suggest that in honeybees octopamine and tyramine modulate the proboscis extension response according to the animals' feeding status. When the bees are hungry the octopamine receptor antagonist epinastine has an effect on the PER, but not when they were fed to satiation before. On the contrary bees that were fed before eliciting the PER were influenced by the tyramine receptor antagonist yohimbine. This effect did not occur in hungry bees. The AmDop2 receptor antagonist fluphenazine had no effect on the PER, whether in hungry or in satiated bees.

We conclude that the biogenic amine tyramine modulate the sucrose sensitivity in satiated bees whereas in hungry bees octopamine is the important modulator. Thus our experiment shows that octopamine and tyramine modulate the honeybees' sucrose sensitivity according to the feeding state.

In search of neural correlates of decisions in honey bees

Hanna Zwaka, Randolph Menzel^{1,2}

¹Freie Universität Berlin, Neurobiologie, Königin Luise Str 28, 14195 Berlin, Germany;

²Bernstein Center for Computational Neuroscience (BCCN), Berlin, Germany

The mushroom body (MB), a higher-order integration center in the insect brain, is known to be involved in storing, retrieving and consolidation of memory. MB extrinsic neurons are expected to code the sensory input according to its value and thus may be involved in decision making between learned responses. We recorded from a putatively inhibitory recurrent pathway the proto-cerebral tract (PCT) during visual learning tasks. PCT neurons change their response properties when bees learn compounds of visual-olfactory stimuli. We hypothesize that acquired response properties allow the MB to separate already learned stimulus combinations from novel ones. Long lasting extracellular multi-unit recordings were performed in animals controlling their visual environment by the movement of an air supported Styrofoam ball. The visual environment consisted of differently colored objects whose virtual distance was indicated by their different motion parallax. In addition the ground structure below the animal and the pattern of an UV illuminated polarization pattern above it provided information about rotatory and translatory movement. Animals were trained in the virtual environment to choose selected objects or routes. Depending on the particular organization of the virtual environment the animal solved simple learned tasks or more complex navigation-like tasks. In addition bees were trained first in a tunnel after arriving from the hive in free flight and then introduced into the virtual environment that presented corresponding visual patterns. The bees transferred the learned behavior from the maze into the virtual environment.

The next step in the search for neural correlates of decision making in honeybees will be to train bees to navigate in a more complex visual virtual environment while recording from MB extrinsic neurons.

'Cognitive enhancement' in *Drosophila* larvae?

Birgit Michels, Maria Pakendorf², Kathrin Franke³, Ludger Wessjohann³, Oleh Lushchak⁴, Dushyant Mishra⁵, Bertram Gerber^{1,6}

¹Leibniz Institute for Neurobiology, Genetics of learning and memory, Magdeburg, Germany

²University of Leipzig, Germany

³Leibniz Institute of Plant Biochemistry, Halle, Germany

⁴Precarpathian National University, Ivano-Frankivsk, Ukraine

⁵Texas A&M Health Science Center, College Station, TX, USA

⁶University of Magdeburg, Germany

Humans traditionally use extracts from *Rhodiola rosea* roots for their anti-stress and 'cognitive-enhancing' remedy. Here, we scrutinize this effect in larval *Drosophila melanogaster*. We want to investigate if food supplementation with *Rhodiola rosea* improves odour-reward associative function, including tests for sensory and motor functions that are relevant for the employed task, as well as general locomotor parameters. Furthermore, we plan to supplement fly food with either commercially available, ground tablets or extract containing *Rhodiola* root material to test for a 'cognitive enhancing' effect. *Drosophila* as a genetically tractable study case should then allow accelerated analyses of the molecular mechanism(s) that underlie the 'cognitive enhancement' conveyed by *Rhodiola rosea*. To the extent that the molecular determinants of 'cognition' are shared between animals and man, such research may have bearings for humans as well.

The reward magnitude in conditioning of the honey bee's proboscis extension response affects memory formation

Kathrin Marter, Lars Bothe¹, Laura Morgenstern¹, Carmen Lewa¹, Dorothea Eisenhardt¹

¹Freie Universität Berlin, Neurobiologie, Königin-Luise-Straße 28/30, 14195 Berlin, Germany

In appetitive classical conditioning the conditioned stimulus (CS) precedes the unconditioned stimulus (US), i.e. the reward. An animal learns the association between the previously neutral CS and the reward and reacts with a conditioned response (CR) when the CS is presented. Thus, an animal learns that the previously neutral CS predicts the occurrence of the reward. The extent to which the CS predicts the reward is thought to determine the associative strength and it is generally accepted that the associative strength is mirrored in the CR during acquisition (Rescorla & Wagner, 1972).

Here we ask about the impact of the reward magnitude on learning and memory formation during classical olfactory conditioning of the proboscis extension response (PER) in harnessed honey bees (*Apis mellifera*). In order to understand the impact of the reward magnitude, we vary the reward concentration during acquisition, study the behavior of the animals, and qualitatively analyze the CR by extracellular recording the activity of the proboscis extending muscle 17. Additionally, we study the molecular mechanisms of long-term memory formation by interfering with protein synthesis. Our results demonstrate that the reward concentration affects acquisition, long-term memory retention, extinction, and the onset of protein synthesis dependent memory formation.

A Network for the Representation of Object Positions in the Central Complex of *Drosophila*

Hannah Marie Wagner, Burkhard Poeck¹, Roland Strauss¹

¹Zoology, Neurobiology, Colonel-Kleinmannweg 2, 55128 Mainz, Germany

The central complex of *Drosophila melanogaster* consists of four substructures: the ellipsoid body, the fan-shaped body, the noduli and the protocerebral bridge. Among other systems, the protocerebral bridge and the fan-shaped body are connected by the horizontal fiber system. The eb-pb-vbo neurons and additional systems connect the ellipsoid body with the protocerebral bridge [Hanesch et al. 1989].

The fan-shaped body holds a visual pattern memory [Liu et al. 2006] and the ellipsoid body a visual orientation memory [Neuser et al. 2008], used for ideothetic orientation when the visual contact to the target is lost. Triphan et al. 2010 proposed that the protocerebral bridge in *Drosophila melanogaster* holds a representation of the fly's acute visual target whereby the azimuth position of the target is decisive for the latero-lateral position of the representation on the bridge. Medial positions represent the frontal visual field, left and right lateral positions the rear left and right visual field, respectively. *ocelliiless*¹ and *tay bridge*¹ are structural brain mutants with a medial disruption of the bridge leading to a high angular scatter in gap climbing behaviour.

Here we show that walking *ocelliiless*¹ and *tay bridge*¹ flies ignore frontally presented landmarks in orientation experiments. Wild-type flies rather approach such frontally presented landmarks, but ignore them like bridge-defective flies, when their eyes are partially frontally occluded. In Buridan's paradigm, where flies alternate between two landmarks of either 12° or 3° width, the orientation of wild-type flies gets more precise, when narrower landmarks are presented. In contrast, *ocelliiless*¹ flies have more significant orientation problems when the landmarks become narrower. Taken together, these results indicate that the protocerebral bridge is involved in the representation of object positions in *Drosophila melanogaster*. Next, we collected evidence that the information to be stored in the ellipsoid-body is loaded through the protocerebral bridge. Indeed, *ocelliiless*¹ and *tay bridge*¹ didn't show a spatial orientation memory when tested in the detour paradigm. *C31* is another structural brain mutant with partially and sagittally interrupted fan-shaped body and ellipsoid body – the flies show no spatial orientation memory. Unexpectedly, we were able to rescue this behavioural defect by driving UAS-*C31* cDNA in the fan-shaped body. We hypothesise that the fan-shaped body is in the output path of information coming from the ellipsoid body, whereas the protocerebral bridge is a constituent of its input pathway.

Rat navigation with visual and acoustic cues in Virtual Reality on a Servo Ball

Ursula Kaupert, York Winter¹

¹Humboldt Universität Berlin, Exzellenzcluster NeuroCure, Kognitive ¹Neurobiologie, Dorotheenstr. 96, 10117 Berlin, Germany

The Virtual Reality Servo Ball is a novel virtual reality experimental system. It is based on an active, servo driven spherical treadmill. It allows a freely moving rodent (mouse, rat) to navigate in virtual space. Virtual reality provides a perfectly controllable experimental environment. It can be used for investigating navigation, cognition, learning and memory. We performed a series of experiments to provide a proof of concept of using the Virtual Reality Servo Ball as an experimental system. We show that rats can recognize and use visual and acoustic spatial cues in this virtual environment.

We determined the time course of place and spatial response learning by rats using different sensory modalities as cues for spatial orientation. Freely moving rats were able to use different information from their surroundings to reach a goal in the virtual environment, similar to the performance of body fixed rats on an air cushioned ball in virtual reality (Hölscher et al. 2005). Our freely moving rats used visual cues both as beacons and as landmarks from which they were able to derive angular information to locate the position of a goal. Experiments were performed with virtual radial arm mazes (visual cues) of conventional dimensions and extending several meters and in an open field (acoustic cues) of both in small and large dimensions.

It was possible to fully automate experimentation with this virtual environment by tagging individual rats with transponder ID chips that allowed individual access through an automated gate access system. This gating system allowed single, individual rats to enter the experimental arena from their social home cage for the duration of single trials. This procedure avoided the potentially stressful handling of individuals and allowed 24-h experimentation. We established a standard protocol of training the rats to use this setup.

Our preliminary findings provide basic procedural information for experimenting with freely moving rats in a virtual reality environment as a prerequisite for further research including electro- or optophysiological methods, telemetry or pharmacological interventions while the animal performs complex behaviour.

Reference

C. Hölscher, A. Schnee, H. Dahmen, L. Setia and H. A. Mallot (2005) Rats are able to navigate in virtual environments, *The Journal of Experimental Biology* 208, 561-569

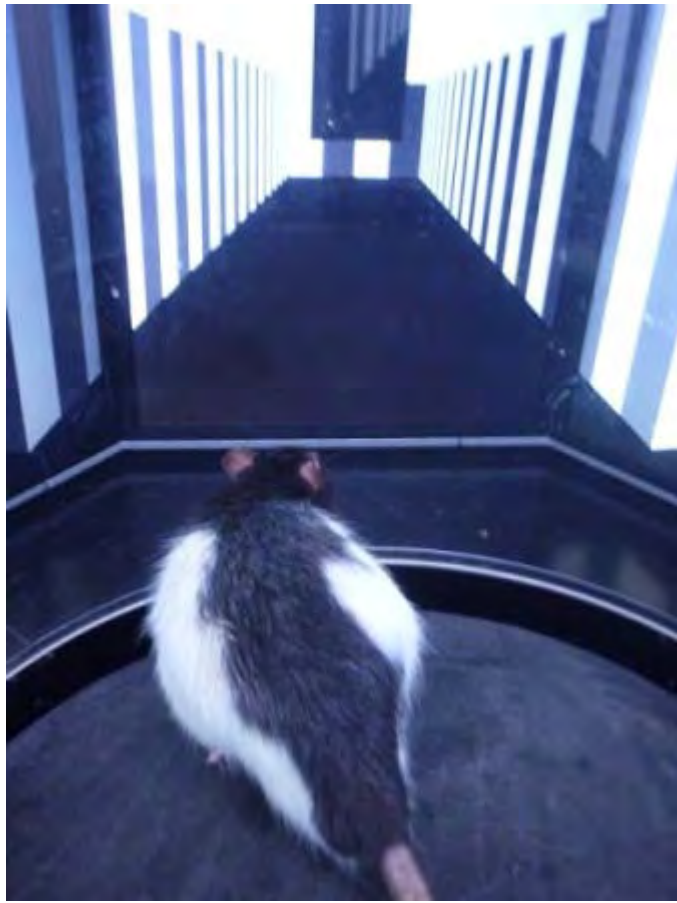

Acoustically guided way-finding in humans: the role of gender and sightedness

Daniel Schmidtke, Sarah Galinski¹, Karl-Heinz Esser^{1,2}

¹University of Veterinary Medicine Hannover, Auditory Neuroethology and Neurobiology Laboratory, Institute of Zoology, Buenteweg 17, 30559 Hannover, Germany

²Center for Systems Neuroscience Hannover, Buenteweg 2, 30559 Hannover, Germany

We examined the role of sound-emitting objects as acoustic landmarks in a medium-scale, indoor way-finding task in fully blind, visually impaired, and fully sighted human subjects (all wearing blackened, rubber-sealed glasses to exclude any visual input). The participants first had to learn to find their way through a walkable maze in which three sound-emitting, acoustic landmarks indicated important waypoints en-route from a fixed starting position to the goal (walking distance approx. 28.5 m). During the subsequent, critical experiment, we modified the acoustic landmarks in order to provoke a behavioural reaction in those subjects that used the landmark information during way-finding. The goal of the study was to investigate to which degree humans make use of sound-emitting, acoustic objects during navigation in a non-visual environment and to test for differences between the two groups *visually impaired/blind* and *sighted* as well as between *male* and *female* participants.

The results demonstrated that, during the initial training phase, gender and sightedness had a significant effect on the number of test trials the subjects absolved before they felt safe enough to proceed to the critical phase of the experiment, with the sighted and female subjects needing more of these test trials than their respective counterpart. During the critical experiment, a substantial amount of individuals from all groups responded to at least one of the landmark modifications. On this individual level, we did not find any significant differences in the number of responding subjects between the male and the female group, but between sighted and visually impaired/blind subjects, with significantly less of the latter reacting to at least one of the landmark modifications. We also used mixed linear models and linear-hypothesis testing to compare the responses to the landmark modifications on the group level. The results from these models mainly reflect the results that have been found in the comparison of the individual reactions to the landmark modifications.

In a third, post-experimental phase, each subject had to model the “ideal path” through the maze using plasticine. The plasticine models were digitised and analysed in order to estimate in how far the subjects were able to establish an inner representation of the maze. We found significant differences between visually impaired/blind and fully sighted subjects (the former produced less accurate models), but no significant differences between the sexes. The group of the sighted subjects additionally answered the German version of the Sensation Seeking Scale - Form V (SSS-V). The individual SSS-V scores were used to check for relations between training performance and the internal mediators parameterised by the scale. Significant correlations were found between training performance and the disinhibition sub-scale of the SSS-V.

Synaptic dynamics in the auditory cortex during learning and memory recall

Kaja Moczulska, Manuel Peter¹, Juliane Tinter¹, Simon Rumpel¹

¹Research Institute of Molecular Pathology (IMP), Dr. Bohr-Gasse 7, 1030 Vienna, Austria

Memory formation and storage are one of the most important functions of the mammalian brain facilitating the adaptation and survival of an animal in a changing environment. It is widely believed that the plasticity of neural circuits allows encoding and storage of new experiences in heterogeneous sets of synapses. A number of distinct biochemical and cellular processes have been described to mediate neuronal plasticity during initial memory formation and consolidation. Interestingly, also during memory reconsolidation triggered by memory recall a number of similar cellular processes have been described. Furthermore, they have been discussed as potential signatures for a modification of memory traces during reconsolidation. However, the impact of memory formation and memory recall on actual structural changes in neuronal circuits is still poorly understood.

Here, we used the mouse auditory cortex as a model structure to observe learning related changes in the context of auditory fear conditioning to so-called 'complex' sounds that are frequency modulated and have power in multiple frequency bands. We first analyzed the expression of the immediate early gene *Arc* using qPCR. We observed elevated levels of *Arc* expression in the auditory cortex after learning and also after the memory recall indicating an involvement of this structure in both processes. Moreover, lesion experiments demonstrated necessity of the auditory cortex for learning and memory recall in used paradigm.

Using *in vivo* two photon microscopy in a transgenic mouse strain (GFP-M, Feng et al. 2000) in which neurons are sparsely labelled with GFP opens the possibility to chronically observe spines, the morphological correlates of excitatory synapses in mammalian pyramidal neurons. We combined *in vivo* imaging of dendritic spines in the auditory cortex of transgenic GFP-M mouse line with auditory fear conditioning, a form of associative learning. We observed an increase of spine formation after paired conditioning in comparison to the basal level of spine turnover forming possibly a part of physical representation of a memory. This observation is reminiscent to previous reports on motor learning (Xu et al. 2009, Yang et al. 2009). Moreover, unpaired conditioning triggered an opposite effect, an increase of spine elimination. These observations could help to distinguish learning and non-learning related activity in the auditory cortex. Finally, we observed that memory recall does not trigger synaptic structural rearrangements in the auditory cortex, thus indicating that memory recall does not simply trigger a replay of processes similar to initial memory formation. This finding that is based on a binary description of spine dynamics capturing the turnover of spines is consistent with a model in which memory reconsolidation rather triggers further stabilisation and not rearrangement of a memory trace.

In summary, these findings show that the auditory cortex plays a role in learning and memory recall of complex sounds. Furthermore, our study also reveals structural correlates of paired and unpaired conditioning in auditory cortex and a dissociation of consolidation and reconsolidation processes on the structural level.

Feng, G., R. H. Mellor, et al. (2000). *Neuron* 28(1): 41-51.

Xu, T., X. Yu, et al. (2009). *Nature* 462(7275): 915-9.

Yang, G., F. Pan, et al. (2009). *Nature* 462(7275): 920-4.

Spatial Orientation of *Apis mellifera* in a LED-Environment

Sören Miehe, Randolph Menzel²

¹Freie Universität Berlin, Institut für Biologie - Neurobiologie

²Freie Universität Berlin, Institut für Biologie - Neurobiologie

The perception and classification of visual cues like color and shape are indispensable components for spatial orientation in natural environment. While an animal forages for food it uses visual cues for navigating. Honeybee navigation was intensively studied in the natural environment, in spatially restricted mazes and simulated realities when flying stationary. We investigate stationary walking honeybees within a LED arena similar to that used for *Drosophila melanogaster*. Rotatory and translatory movements of the bee are transmitted to a styrofoam ball floating on air and measured with two laser-sensors. Single and a double stripe patterns are displayed by the LED arena. The goal of our experiments is to study a simple form of decision making. Animals first steer towards a single bright stripe directly ahead, and then need to decide which of the two equally spaced bright stripes it will choose.

Our results show that the option to choose between two visual cues after steering towards a single cue leads to a decision process in which the bee follows just one cue after observing two options. The test bees remember which direction they had chosen before, and follow the same stripe position in a second trial ignoring the other direction. Furthermore the relative stay during the observation period leads to the direction which the bee will choose afterwards. For instance, before the bee decides to steer towards the right stripe it focuses on the right stripe as indicated by minor rotatory movements into the direction towards right. These findings indicate that future decisions are initiated by multiple transient rotatory tendencies. Future experiments will combine the behavioral task with multi unit extracellular recordings from high order interneurons in the bee brain aiming to uncover neural correlates of simple decision making processes.

The potential function of CaMKII in long-term memory in the honeybee

Christina Scholl, Wolfgang Rössler¹

¹Universität Würzburg, Behavioral Physiology and Sociobiology, Am Hubland, 97074 Würzburg, Germany

Honeybees are excellent models to study learning and memory processes. They are well known for their complex behaviours and their abilities to learn complex tasks associated with central place foraging, such as visual navigation or to learn and remember odor-reward associations over relatively long periods of time. The neuronal and molecular bases underlying long-term memory and the resulting plasticity in behaviour is key to understanding higher brain function and social organization.

One protein known to play an important role in memory processes in mammals is the calcium-calmodulin dependent protein kinase II (CaMKII). This protein is an abundant synaptic protein that has been shown to contribute to memory storage and to be an important mediator of learning and memory. Long-term potentiation (LTP) in the CA1 region of the mammalian hippocampus has been a primary model to study the cellular and molecular basis of memory. In the honeybee the mushroom bodies (MB) are known as important sensory integration and association centers involved in learning and memory. Therefore, it is not too surprising that the CaMKII gene and protein was found at high concentrations in the MBs of adult bees with a particularly high concentration in dendritic regions of a clearly delineated subset of spiny Kenyon cells (non-compact, class I KCs) - intrinsic neurons of the MBs (Kamikouchi et al., 2000 JCN 417:501; Pasch et al., 2011 JCN 519:3700). Recent experiments have shown that long-term olfactory memory in the honeybee leads to synaptic reorganization in olfactory subregions of the MB calyx (Hourcade et al., 2010 J Neurosci 30:6461). Here we ask whether CaMKII is involved in the process of long-term memory formation.

To study the role of CaMKII in the formation of long-term memory, honeybees are trained using a classical conditioning paradigm, the proboscis extension response (PER) with sugar reward as the unconditioned stimulus and odor as the conditioned stimulus. To be able to investigate the potential role of CaMKII we started to disrupt the function of CaMKII using RNA interference (RNAi) techniques. siRNA against CaMKII was used to induce RNAi and to create a loss of function (knock down) phenotype in the MBs. Furthermore, we use pharmacological inhibition of CaMKII as a parallel approach. The siRNAs (@CaMKII, @GFP) and the inhibitors (KN93, KN92: ineffective analog) were injected in the brain through the ocellar tract to specifically reach the MBs, which was visually confirmed by fluorescently tagged siRNA. Quantitative immunoblots showed a successful downregulation of the protein 6 hours after the injection of the siRNA, but no effect 4 and 24 hours after the injection. Based on these results PER training using a well established spaced conditioning paradigm are performed 6 hours after the injection of the siRNA to test the influences of the CaMKII on memory acquisition and retention at 1h, 24h and 48h after the learning trials. In the long run the experiments are aimed to understand the potential role of CaMKII as a molecular link in the formation of long-term memory in the honeybee.

(CS is supported by the Graduate School of Life Sciences, GSLS, University of Würzburg)

Melatonin dependent changes in Birdsong - measuring changes in brain activity of freely behaving zebra finches

Susanne Seltmann, Lisa Trost¹, Andries TerMaat¹, Sebastien Deregnacourt², Manfred Gahr¹

¹Max Planck Institute for Ornithology, Department of Behavioural Neurobiology, Eberhard-Gwinner-Str.6a, 82319 Seewiesen, Germany

²Laboratoire d'Ethologie et Cognition Comparées, Université Paris Ouest Nanterre La Défense

Bird song is a complex motor behavior resulting in frequency-modulated sounds produced by the syrinx and the respiratory apparatus of the bird. The specific song patterns are, similar to human speech, shaped during a sensorimotor sensitive period in which auditory feedback guides vocal learning. In zebra finches the song motif of adult males is highly stereotyped with only a small temporal drift during long singing bouts and evolves in two steps. In an early sensory phase a song memory is formed influenced by the “tutor”, an adult male zebra finch. Thereafter, the juvenile bird’s song gets adjusted to the tutor’s song during several weeks of sensorimotor learning. The crystallized, final version of the individual song shows a temporally constant, sequential pattern without further modification.

Responsible for the song learning process as well as for the song production is a neural network of song nuclei, the Song Control System – the birds’ equivalent to mammals’ auditory cortex.

The neurons of two sensorimotor areas of the descending leg of the song control circuit, HVC (proper name) and RA (nucleus robustus arcopallialis), express melatonin-1B receptors. The hormone melatonin is well known for its role in entrainment of circadian and circannual rhythms and melatonin receptors are therefore mainly found in areas of the circadian system such as the retina, the suprachiasmatic nucleus and neuroendocrine areas of birds and mammals including humans.

Because RA and HVC have no known clock function and are crucial for the organization of the song pattern, melatonin, in this case, is supposed to have a direct function in the neural control of the motor pattern and, in consequence, to alter a sexual signal, the song of the zebra finch.

Zebra finches’ RA neurons fire continuously at a constant rate in the absence of a stimulus but burst while singing and in reaction to artificial playback of the birds’ own song (BOS) during sleep. Furthermore, we observe similar activity of the same neurons during sleep not triggered by an external stimulus, which is therefore thought to be a form of unconscious song repetition.

After a normal night, elongation of song elements can be observed. When we prevent the birds from producing melatonin e.g. by keeping them in constant light (LL), the song elements are shortened. Systemic administration of Melatonin at the onset of a night in LL causes a change in song similar to a normal night. Apparently, night-sleep and melatonin treatment during LL have the same effect on the vocal control system and therefore on brain activity and song structure.

To verify this correlation and find out more about the role of melatonin in birdsong we chronically implant electrodes in RA of male zebra finches and use wireless transmitters to get unit recordings of RA neurons. The lightweight (~1g) and wireless design of the transmitters allows normal behavior patterns almost without limitation.

The results are discussed in the view of recent findings concerning neuronal activity in the song control system.

Calling behaviour of Zebra Finches (*Taeniopygia guttata*) forced pairs and activation pattern of a pallial song nucleus during unlearned vocalizations.

Pietro Bruno DAmelio, Lisa Trost¹, Andries ter Maat¹

¹Max Planck Institute for Ornithology, Department Gahr - Behavioral Neurobiology, Eberhard-Gwinner-Strasse, 82319 Seewiesen, Germany

Studies on birds' vocalizations have principally focused on songs, whereas the study of unlearned calls has not been given proper attention. To understand the principles of avian vocal communication a thorough comprehension of call usage is necessary. Zebra finches emit thousands of calls daily. However, the exact number of call types, their functions and their inter-individual interaction patterns are not fully described and understood. This lack of knowledge mainly derives from the absence of appropriate tools for: i) recording all the vocalizations individually and ii) studying calls' neural basis in freely behaving animals. This work had two main aims: i) correlate calling and social behaviours of forced pairs of zebra finches; ii) show the involvement of a telencephalic nucleus during unlearned vocalizations. In a first experiment miniaturised backpack microphones were used to record the total daily vocal production by zebra finches placed together in a cage (forced pairs). We used synchronized video and audio recordings to correlate birds' behaviour with vocalizations. We first showed that after a short acclimatisation the backpack microphones have no influence on either behaviour or vocalisations. We then compared vocal and social aspects of the behaviour of already formed pairs and birds that had not met before. Pairs of zebra finches are characterized by the presence of particular behaviours such as clumping and allopreening and by pair coordination of behaviours (e.g. preening at the same time). We quantified these behaviours for each pair. Quantitative and qualitative analysis of temporal associations between individual calls revealed that these are used in bidirectional communication: precise patterns of associated calling are established between members of a pair. We found that pairs are characterised both by the presence of the specific behaviours mentioned above and by alternated communication. Moreover, during the process of pair formation there is a strong correlation between the increasing of "pairing behaviours" (i.e. clumping and allopreening) and the index that measures the strength of the calling association.

In a second experiment males were equipped with a chronically implanted electrode to record Local Field Potentials (LFP) from the Nucleus Robustus of the Arcopallium (RA). In songbirds RA is located in the intermediate arcopallium; its activation is necessary during production of learned vocalizations. Although it has been shown that RA is necessary for the modulation of the spectro-temporal features of learned vocalization, we found that it also showed a consistent change of activity during both learned and unlearned vocalizations. This pattern of activity suggests an involvement of this nucleus and therefore, the forebrain motor pathway, also during unlearned vocalizations. The function of this activation pattern has not been described. We speculate that RA, and/or other upstream telencephalic areas, play a role in the regulation of all communication including calling.

The quantitative description of calling behaviour will allow us to clarify the role of RA in vocal communication.

A laboratory test of spatial recognition in solitary and social bees

Nanxiang Jin, Randolph Menzel¹

¹Institut für Neurobiologie, Freie Universität Berlin, Neurobiology, Königin-Luise-Str. 28-30, 14195 Berlin, Germany

Navigation is an important cognitive faculty in Hymenopteran insects when finding their way back home after foraging and searching for new nest sites. We set out to develop a laboratory test of spatial recognition using a solitary bee species (*Osmia rufa*) and two social bees, honeybees (*Apis mellifera*) and bumblebees (*Bombus terrestris*). Our final goal will be to combine these tests with chronic recordings from high order neurons. The test apparatus consists of an arena (31.5 x 31.5 cm) that provides both local cues and panorama patterns. A single bee is trained to feed at a location characterized both by a local cue (a blue cardboard, 5x5 cm) and a position relative to the panorama. In following tests, we change the relative positions between local cue and the panorama. The walking pattern of the single test bee is video recorded during the learning and test sessions. As a control walking patterns are also recorded in red light which bees do not see. The analysis of the walking trajectories indicates that *Osmia* is particularly suitable for these tests showing that the local cue and the location characterized by the panorama can be set into competition. Under these conditions *Osmia* shuttles between the two locations during test sessions. Bumblebees also showed the similar shuttling behavior in tests when local cue and panorama are indicating the same food source at different locations. However, honeybees are much less motivated in the same trainings and tests and, therefore failed to show their spatial learning ability maybe due to their sensitivity to being isolated from the social contacts.

Subcellular distribution of Ependymins and their binding Partners

Roman Göthe, Rupert Schmidt¹

¹Justus-Liebig-University Giessen, Biotechnology Centre, Leihgesterner Weg 217, 35392 Gießen, Germany

Ependymins are secreted glycoproteins of the central nervous system (CNS) in goldfish (*Carassius auratus*). They exist in a mono-N-glycosylated (= γ) and a bi-N-glycosylated (= β) form. Ependymins are known to take part in memory consolidation and neuronal regeneration. After active shock avoidance conditioning ependymin mRNA is rapidly induced in goldfish meningeal fibroblasts followed by enhanced ependymin synthesis and secretion. Memory consolidation was inhibited both, after blocking ependymin with anti-ependymin antisera and with antisense-oligodesoxynucleotides via intracranial injection.

Previous studies on goldfish brain exhibited a distinct distribution of ependymins and other proteins in various subcellular fractions of the CNS. The major portion of ependymins was localized in the cytoplasm, whereas in the extracellular fluid, ependymins are the most prominent protein components (highest specific concentrations). Detailed studies of the pelleted fractions (P_1 to P_3) revealed a differentiated distribution of ependymins with the lowest specific concentration in the mitochondrial/synaptosomal fraction (P_2) and the highest specific concentration in the microsomal fraction (P_3).

Because ependymins operate via the extracellular brain fluid in memory consolidation and regeneration processes, it is necessary to identify their interaction partners to understand ependymins' molecular function. Therefore, the different fractions were analyzed by co-immunoprecipitation, 2D-gel electrophoresis and Far-Western-Blotting with radioactive [¹²⁵I]-labeled ependymins. 17 different proteins between 20 and 55 kDa showed binding of ependymins. These proteins have different distributions in various subcellular fractions. Some are present in almost all fractions, whereas others are present in only one fraction. Furthermore, [¹²⁵I]-ependymin binding to endogenic ependymin was shown in the extracellular fraction, in the vesicular fraction (P_3) and in a fraction of glycoproteins separated from cytoplasm or the brain extracellular fluid by Concanavalin A affinity chromatography. In these three samples ependymin is the most prominent protein. Apparently ependymin preferentially binds to other proteins present, as compared with homophilic binding to ependymin itself.

Impact of chronic and acute BDNF deficiency on fear learning and fear extinction

Thomas Endres, Volkmar Lessmann^{1,2}

¹Otto-von-Guericke University Magdeburg, Institute of Physiology, Leipziger Str. 44, 39120 Magdeburg, Germany

²Center for Behavioral Brain Sciences (CBBS), Magdeburg, Germany

Beyond its trophic function, the neurotrophin BDNF (brain-derived neurotrophic factor) is also an important mediator of synaptic plasticity. Recently, BDNF has been shown to be crucial for amygdala-dependent fear learning. In these studies BDNF-signaling was impaired either by acute pharmacological blockade of Trk-receptors, or by a region-specific overexpression of non-functional truncated TrkB-receptors. Interestingly, studies using heterozygous BDNF knockout mice (BDNF^{+/-}) consistently reported no impairments of cued fear learning in this mouse line so far. One of the main aims of the present study was to analyze these seemingly discrepant observations between chronic and acute BDNF depletion. Since it has been shown that the amount of BDNF protein declines during aging we hypothesized that older BDNF^{+/-} mice might exhibit fear learning deficits while fear learning in younger animals is still intact. In order to test our hypothesis, we analyzed the fear learning abilities of differently aged BDNF^{+/-} mice and wild type littermates. We observed an age-dependent learning deficit in BDNF^{+/-} mice when they were 3 months of age or beyond. Since our results further show that short term fear memory in these animals is still intact this learning deficit is most likely due to a memory consolidation deficit. In addition, we quantified the BDNF protein amount of the tested animals by using a sensitive BDNF-ELISA and observed a positive correlation between the amount of BDNF protein in the amygdala and the individual fear learning performance. Besides the deficit in fear learning, we could also identify a deficit in fear extinction learning in 7 months old BDNF^{+/-} mice, whereas extinction learning in 2 months old BDNF^{+/-} mice was intact. This learning deficit was also accompanied by strong reductions of BDNF protein in brain areas relevant for fear extinction learning, i.e. hippocampus, medial prefrontal cortex and basolateral amygdala.

In order to compare the impact of chronic with acute BDNF depletion, we started to acutely interfere with BDNF-TrkB-signaling by local application of the Trk-inhibitor K252a in the basolateral amygdala of wild type mice at different time points around the fear conditioning training. Here we could identify two distinct k252a sensitive time points for the acquisition and early consolidation of cued fear memories.

In conclusion, the present study demonstrates age-dependent learning deficits in BDNF^{+/-} mice in fear learning as well as in the extinction of conditioned fear. Furthermore, our experiments provide evidence for the existence of distinct time windows for TrkB signaling in different phases of fear learning, suggesting an important role of BDNF/TrkB-signaling in the acquisition and consolidation of fear memory.

This work was supported by the SFB 779/B6 as well as by the federal state of Saxony-Anhalt and the "European Regional Development Fund" (ERDF 2007-2013), Vorhaben: Center for Behavioral Brain Sciences (CBBS).

Modelling the interaction of synaptic and structural plasticity

Michael Fauth, Christian Tetzlaff¹, Florentin Wörgötter¹

¹Bernstein Center for Computational Neuroscience, Drittes Physikalisches Institut, Georg-August-Universität Göttingen, Friedrich-Hund-Platz 1, 37077 Göttingen, Germany

Recently it has been shown that learning is associated with structural changes in neural tissue. The underlying mechanism, named structural plasticity, drives the formation of new synapses and the removal of existing ones on a timescale of days and weeks. This enlarges the potential for information storage in neuronal networks and is thus important for understanding long-term memory formation. On shorter timescales (minutes to hours) another process, named synaptic plasticity, which influences the transmission efficiencies (weights) of a synapse, also contributes to information storage.

We investigate the interaction between these two processes – still widely unknown – in the following rather simple model: We use rate based neurons with the total transmission efficiency between two neurons being just the sum of weights of all synapses connecting these two neurons. Thus, the number of synapses as well as their weights influence the same quantity and we can investigate the effects arising from structural and synaptic plasticity competing on different timescales. Synaptic plasticity is modeled by Hebbian learning with weight dependent synaptic scaling. For structural plasticity we propose a model, consisting of three processes: First, we have an activity dependent outgrowth and retraction of dendritic arbors. The growth process determines the number of potential synaptic sites. Second, the formation of a synapse at each of these potential synaptic sites happens at random with a fixed formation probability. Third, the removal of existing synapses also happens randomly, but with a weight-dependent probability.

Although both processes are quite complex, we can show that the system converges to a stable state. In this state the activity determines the probability distribution of number and strength of the synapses between neurons. The combined mechanisms could also serve to form non-random features in connectivity or highly interconnected clusters, which are candidates for memory representation.

The role of microRNAs in learning and memory the honeybee brain

Julia Rennertz, Uli Müller¹

¹Universität des Saarlandes, FR 8.3, Zoologie/Physiologie/Neurobiologie, Campus Gebäude B2 1, 66123 Saarbrücken, Germany

Memory formation and its mechanisms become unravelled more detailed very quickly lately. Understanding the molecular processes regulated during the training phase is one important aspect of explaining the different aspects of memory formation. MicroRNAs are an essential part of these molecular processes. They are short (18-30nt), non-coding ribonucleic acids, regulating processes like transport and degradation by silencing gene expression on the post-transcriptional level. MicroRNAs also play a critical role in learning and memory formation processes via regulating important proteins such as CREB and Mef2. This work aims at the identification of microRNAs involved in memory formation and synaptic plasticity in the honeybee brain and the establishment of a method for the quantification of these microRNAs.

Bidirectional acetylation-mediated modulation of memory in the honeybee: search for the targeted genes

Katja Merschbaecher, Uli Mueller¹

¹Saarland University, Dept. 8.3 Biosciences Zoology/Physiology-Neurobiology, Campus, 66123 Saarbrücken, Germany

Regulation of gene expression plays an essential role during development and also in numerous physiological processes including learning and memory formation. Gene expression is regulated by the activation of the transcription machinery and the chromatin structure. The latter regulation process includes DNA methylation and histone modification. While hyper-acetylation of histone tails leads to an open chromatin structure facilitating the transcription process, hypo-acetylation has the opposite effect. These processes are catalysed by histone acetyl transferases (HATs) and histone deacetylases (HDACs). Learning induced changes in protein acetylation mediated by these enzymes play an important role in memory formation. While many studies report the role of elevated acetylation in memory facilitation, the role of memory suppression by learning induced reduction of acetylation is not well understood. In our study we addressed the impact of both, increased and decreased acetylation, on formation of memory in the honeybee. To search for the genes affected by the bidirectional changes in histone acetylation we adapted and applied a method that allows studying de novo mRNA during the time course of memory consolidation.

Enhancement of Olfactory Acuity via Differential Conditioning of Similar Odors

Jonas Barth, Shubham Dipt¹, Moritz Hermann¹, Thomas Riemensperger¹, André Fiala¹

¹Dept. Neurobiology of Behavior, Georg-August University Göttingen, Germany

In associative learning animals can connect sensory stimuli with a reward or a punishment. Fruit flies can associate an odor with a punishing electric shock and avoid the learned odor. If the stimulus is slightly different from the learned stimulus, the animal has to evaluate the sensory input and act accordingly: the fly reacts to similar odors with a learned response (generalization). However, similar stimuli might also have different consequences. Does the fly learn to differentiate between similar odors to develop the necessary olfactory acuity?

Olfactory information in *Drosophila melanogaster* is known to be perceived by sensory neurons located on the antennae and maxillary palps. Olfactory sensory neurons project into the antennal lobes where they arborize in distinct glomeruli. The glomeruli are intra- and interconnected via inhibitory and excitatory local interneurons and projection neurons convey the information to higher brain centers, e.g. the mushroom bodies that are critical brain structures for associative olfactory learning.

We are using an associative learning paradigm to test whether flies perceive odors as similar or dissimilar. We demonstrate that two chemically similar odorants are generalized by the flies. Additionally, we show that flies can be trained to better discriminate these odorants if a differential training procedure is used. With the help of genetic techniques to specifically block transmitter release, we tackle the question if transmitter release from subsets of local interneurons in the antennal lobes is required for discrimination learning of similar odorants. We used *in vivo* calcium imaging to visualize the activation pattern of olfactory sensory neurons in the antennal lobe in response to the used odorants. In addition, we monitored neuronal activity in projection neurons before and after differential training to correlate the learned similarity of odorants with odorant representations at the level of the antennal lobe and the mushroom body calyx.

Developmental changes in lateral amygdala inhibitory circuits

Daniel Bosch, Ingrid Ehrlich¹

¹HIH/CIN, Physiology of Learning and Memory, Otfried-Mueller-Strasse 25, 72076 Tuebingen, Germany

In adult animals, the lateral amygdala (LA) is a major site for acquisition and storage of the CS-US association during pavlovian fear learning. Sensory thalamic and cortical pathways converge onto LA principal neurons and are under tight control of local GABAergic interneurons. Furthermore, GABAergic inhibition plays a critical role in synaptic plasticity and fear and extinction learning. Behavioral experiments show that fear learning in rodents first appears at the infant to juvenile transition, and differences in fear and extinction learning mechanisms continue into adulthood. Additionally, behavioral pharmacology studies suggest that expression of extinction in juveniles is not influenced by modulators of GABAergic activity. However, the underlying cellular and synaptic processes of early life fear and extinction learning have been largely unexplored.

Here, we investigate changes in synaptic properties of excitation and feed-forward inhibition in LA principal neurons during the critical time windows when behavioral learning changes in infant, juvenile, adolescent and adult mice. Using whole-cell patch-clamp recordings in slices we show that stimulation of afferent thalamic and cortical sensory fibers reveals a differential developmental regulation of amplitude and release probability of direct excitatory inputs as well as magnitude of feed-forward inhibition onto LA principal neurons. Furthermore, the effect of the GABA_B antagonist CGP 55845 suggests a developmentally regulated influence of GABAergic modulation on excitatory and feed-forward inhibitory sensory inputs as well as heterosynaptic inhibition of excitatory thalamic and cortical inputs.

Taken together, our data suggest a developmentally regulated change in basic synaptic properties of sensory synapses onto LA principal neurons and an increasing influence of GABAergic modulation in mouse lateral amygdala.

Effects of neonicotinoid insecticides on honeybee homing flight behavior using harmonic radar tracking

Johannes Fischer, Teresa Müller¹, Anne-Kathrin Spatz², Bernd Grünewald¹, Randolph Menzel³

¹Goethe Universität Frankfurt am Main, Institut für Zellbiologie und Neurowissenschaften

²Universität Kassel, Ökologische Agrarwissenschaften

³Freie Universität Berlin, Institut für Biologie - Neurobiologie

Honeybees may encounter a variety of harmful chemicals during foraging. Among them are the neonicotinoid insecticides, that are widely used in current agriculture as a pesticide.

They act as agonists of the insect acetylcholine receptor and are supposed to have no effect on the mammalian acetylcholine receptor, rendering it harmless to humans and farm animals. Although bees are not a target of these chemicals, they are also affected by them. Bees that were exposed to non-lethal doses of different neonicotinoids show various influences on behavior or motor activity, depending on the different neonicotinoid class they were exposed to.

We investigated the influence of sub lethal doses of the neonicotinoids clothianidin, imidacloprid and thiacloprid on the ability of bees to orientate during homing flights. Bees were equipped with a transponder and their full flights were tracked with harmonic radar. The bees were trained to an artificial feeder, then caught and fed with sugar water containing one of the neonicotinoids. Then they were displaced and released with a radar transponder. We recorded the flight traces from the release site back to the hive and found that bees rely initially on vector-orientation confirming earlier findings. All bees headed first into a direction in which they expected to find their hive, if they would have returned from the feeder. The influence of the different treatments became apparent during the following part of the homing flight, the way from the expected hive site to the real hive. Thiacloprid treatments led to a temporary inability to find the hive, resulting in a significant reduced number of bees that returned to the hive in the observation period. Neither imidacloprid nor clothianidin treatments had such striking effects, clothianidin even appears to shorten homing flights as compared to the control group.

Bees rely on both, landmark- and vector-orientation for normal orientation in, for example, a foraging trip. Our data suggest that neonicotinoids can have an influence on proper orientation in bees, with an impact on landmark-orientation.

The sequence of stimulus presentations during conditioning is critical for memory formation and affects the amount of CREB

Johannes Felsenberg, Jenny Aino Plath¹, Dorothea Eisenhardt¹

¹Freie Universität Berlin, Neurobiology, Königin Luise Str 28-30, 14195 Berlin, Germany

In classical conditioning, the presentation of an initially neutral stimulus, the conditioned stimulus (CS), is preceding the presentation of an unconditioned stimulus (US). After successful conditioning the CS is eliciting a CR, indicating that the CS gained excitatory properties. The sequence of stimulus presentations is critical for the properties of the CS gained during conditioning: When the sequence of stimulus presentations is reversed, such that the US precedes the CS, the CS might not gain excitatory properties anymore but inhibitory properties instead. After classical conditioning short- and long-term memories about the excitatory properties of the CS are formed. But it is less clear what is memorized when animals experience a reversed conditioning protocol: Does the CS acquire excitatory properties, inhibitory properties or both? Accordingly, we here aim to understand the impact of the sequence of CS and US presentations on memory formation. We examine short-term and long-term memories formed after classical conditioning and conditioning with a reversed protocol, which we here term “backward” conditioning. We study backward conditioning in the honeybee (*Apis mellifera*), a well-known invertebrate model organism for learning and memory research. In a behavioral analysis we demonstrate that after classical and backward conditioning animals generalize a novel stimulus. However, long-term memory formation about the excitatory properties of the CS is only observed after classical conditioning, whereas the CS gains short-term and long-term inhibitory properties after backward conditioning. A Western blot analysis reveals that the amount of AmCREB, a homologue of the vertebrate transcription factor CREB (cAMP response element binding protein), differs between classically conditioned and backward conditioned animals. Accordingly, the sequence of stimulus presentations impacts the amount of AmCREB. This finding might indicate that the amount of CREB is crucial for memory formation about the stimulus sequence experienced during conditioning.

5-HTT Genotype Influences Spatial Learning and the Expression of Different Markers of Neuroplasticity

Margherita Maria Lee, Sina Kollert^{1,2}, Magdalena Weidner^{1,2}, Sandra Grauthoff^{3,4},
Rebecca S. Heiming^{3,4}, K.P. Lesch², Norbert Sachser^{3,4}, Lars Lewejohann^{3,4}, Angelika
G. Schmitt¹

¹Department of Psychiatry, Psychosomatics and Psychotherapy, University of Würzburg, Würzburg, Germany

²Molecular Psychiatry, Department of Psychiatry, Psychosomatics and Psychotherapy, University of Würzburg, Würzburg, Germany

³Department of Behavioral Biology, University of Münster, Münster, Germany

⁴Otto Creutzfeldt Center for Cognitive and Behavioral Neuroscience, University of Münster, Münster, Germany

Learning and memory processes are known to be influenced by the serotonergic system as well as stress. One important brain region for learning and memory is the hippocampus. The birth of new neurons in the adult hippocampus, adult hippocampal neurogenesis, as well as the expression of immediate early genes (IEGs), which are markers for neuronal activity, have also been discussed to play a role in learning and memory. As serotonin transporter (5-HTT) knockout (KO) mice display an altered stress response, we tried to ascertain in this study whether spatial learning is affected by 5-HTT genotype and differences in the aversiveness of testing conditions.

Therefore, 5-HTT KO, heterozygous (HET), and wild-type (WT) mice were subjected to a 5-day series of repeated trials in either a water maze (WM) or a Barnes maze (BM). WM is discussed to be more aversive than BM. For the evaluation of adult neurogenesis (aN) and IEGs expression, brains of 5-HTT KO and WT mice underwent quantitative immunohistochemistry detecting the neurogenesis markers Ki-67 and NeuroD and the IEGs cFos and Arc. As recent studies have pointed to different functions of the anterior and posterior hippocampus as well as of the upper and lower blade of the dentate gyrus (DG), we analysed them separately. Additionally, an independent group of mice was used to measure plasma corticosterone (CORT) concentrations.

Our results show that 5-HTT KO mice performed significantly worse compared with 5-HTT HET and WT mice in the WM, but not in the BM. The singular experience of either learning test led to significantly increased CORT levels compared to untested control mice, but significant 5-HTT genotype effects couldn't be revealed. However, CORT levels of 5-HTT KO mice, but not of HET and WT mice, were distinctly higher in the WM than in the BM. Quantitative immunohistochemistry revealed that the number of IEG expressing cells in the granule cell layer (GCL) of the DG was exclusively affected by the 5-HTT genotype and not by learning tests. 5-HTT KO mice were found to have significantly more cFos-positive(+) cells primarily in the upper DG-blade of the anterior hippocampus, while they had significantly more Arc+ cells in the upper DG-blade of the entire hippocampus. Comparable to the IEG results, analyses of cells immunoreactive for two different aN markers, the proliferation marker Ki67 and the marker for immature neurons NeuroD, primarily revealed 5-HTT genotype effects. 5-HTT KO mice were found to have more Ki67+ and NeuroD+ cells than WT mice primarily in the subgranular zone (SGZ) of the upper DG-blade of the entire hippocampus (this is true for Ki67) and exclusively of the posterior hippocampus (this is true NeuroD). However, quantification of Ki67+ cells localized in the total SGZ of the anterior hippocampus revealed a gene x environment interaction. WT/WM animals had significantly more Ki67+ cells than WT controls and we detected a trend for more Ki67+ cells in KO compared to WT controls. However, no significant difference was found between KO controls and KO/WM animals, or

WT/WM and KO/WM animals.

In conclusion, performance differences between 5-HTT KO and WT mice in the WM could be mediated by differential stress sensitivity of these mice. Higher baseline neuronal activation levels in 5-HTT KO compared to WT mice as shown via an increased number of cells positive for IEGs and aN markers could also have an impact on the diverging learning performances.

Synaptic proteome changes in mouse brain regions upon auditory discrimination learning

Angela Kolodziej, Thilo Kähne³, Karl-Heinz Smalla⁸, Elke Eisenschmidt⁴, Utz Uwe Haus⁴, Robert Weismantel⁵, Siegfried Kropf⁶, Wolfram Wetzel⁷, Frank W Ohl¹, Tischmeyer Wolfgang⁸, Michael Nau, mann³, Eckart D. Gundelfinger⁹

¹Leibniz Institute of Neurobiology, Systems Physiology of Learning, Brenneckestraße 6, 39118 Magdeburg, Germany

²Otto-von-Guericke University, Institute for Biology, Leipziger Straße 44, 39120 Magdeburg, Germany

³Institute of Experimental Internal Medicine, Medical School, Otto von Guericke University, Leipziger Straße 44, 39120 Magdeburg, Germany

⁴Institut für Mathematische Optimierung, Medical School, Otto von Guericke University, Universitätsplatz 2, 39106 Magdeburg, Germany

⁵Institut für Operations Research, Eidgenössische Technische Hochschule Zürich, Rämigstraße 101, 8092 Zürich

⁶Otto-von-Guericke University, Institut für Biometrie und Medizinische Informatik, Leipziger Straße 44, 39120 Magdeburg, Germany

⁷Leibniz Institute of Neurobiology, Behavioral Pharmacology, Brenneckestraße 6, 39118 Magdeburg, Germany

⁸Leibniz Institute of Neurobiology, Molecular Biological Techniques, Brenneckestraße 6, 39118 Magdeburg, Germany

⁹Leibniz Institute of Neurobiology, Neurochemistry and Molecular Biology, Brenneckestraße 6, 39118 Magdeburg, Germany

Changes in synaptic efficacy underlying learning and memory processes are assumed to be associated with alterations of the protein composition of synapses. We performed proteomic screens of the synaptic proteome of four brain areas (auditory cortex, frontal cortex, hippocampus striatum) during auditory learning. Mice were trained in a shuttle box GO/NO-GO paradigm to discriminate between rising and falling frequency modulated tones to avoid mild electric foot shock. Control-treated mice received corresponding numbers of either the tones or the foot shocks. Six hours and 24 h later, the composition of a fraction enriched in synaptic cytomatrix-associated proteins was compared to that obtained from naïve mice by quantitative mass spectrometry. In the synaptic protein fraction obtained from trained mice, the average percentage (\pm SEM) of downregulated proteins ($59.9 \pm 0.5\%$) exceeded that of upregulated proteins ($23.5 \pm 0.8\%$) in the brain regions studied. These data suggest that learning processes initially induce removal and/or degradation of proteins from presynaptic and postsynaptic cytoskeletal matrices before these structures can acquire a new, postlearning organisation.

Mapping of regional brain activity during two-way active avoidance (TWA) behavior using *in vivo* SPECT-imaging in rats.

Anja Mannewitz, Jürgen Goldschmidt², Katharina Braun¹

¹Otto von Guericke University, Institute of Biology, Department of Zoology/Developmental Neurobiology, Magdeburg, Germany

²Leibniz Institute for Neurobiology, Auditory Learning & Speech, Magdeburg, Germany

We recently described regional metabolic brain activity and functional connectivity in rats undergoing two-way active avoidance (TWA) training in the shuttle box using 2-Fluoro-deoxy-glucose (2-FDG) autoradiography. In contrast to adolescent rats (P38-P42), infant rats (P17-P21) do not learn the TWA task despite intensive training. This difference in the behavioral output is reflected by the degree of functional coupling of a number of brain regions related to emotional-autonomic circuits. Thus, in adolescent rats, the metabolic activities of the cortico-limbic, hippocampal, amygdaloid, striatal and brain stem regions as well as primary sensory and motor areas measured significantly correlate among each other; the only regions that are functionally not coupled are the infralimbic cortex and central nucleus. In infant rats displaying a poor TWA performance, the metabolic activities of the caudal hippocampus, rostral subiculum, central and medial nuclei of the amygdala are not coupled with the other brain regions. Meaning, TWA learning depends on age, but we showed also TWA learning during adulthood is accelerated after pre-training as infants. Our hypothesis is infant pre-training engraves a “memory trace” and will facilitate the development of an avoidance strategy in the adult animal during retraining compared to non pre-trained animals. The developmental differences in avoidance performance is due to a differential recruitment of brain regions involved in the TWA task. To test this we apply repeated *in vivo* SPECT-imaging in one individual, because a disadvantage of 2-FDG autoradiography is that patterns of neuronal activity can be mapped only once. Thus, e.g. developmental learning aspects cannot be followed up within one individual animal. In order to circumvent this problem, we employed small animal single photon emission computed tomography (SPECT)-imaging of regional cerebral blood flow. Two groups (pre-trained and non pre-trained group) of adult rats were catheterized via the external jugular vein and injected with the blood flow tracer 99m-Technetium HMPAO at different training stages i.e. during the 1st (acquisition phase) and 5th (retrieval phase) day of TWA training in the shuttle box.

This makes it possible to monitor individual and ontogenetic changes in regional brain activity related to acquisition and retrieval of the TWA task.

Supported by a graduate fellowship (to A.M.) from the Ministry for Science and Education Saxony-Anhalt and the European Regional Development Fund (ERDF).

Detection of object-space novelty in the CA1 of freely behaving mice induces LTD which is dependent on NMDA and mGlu5 receptor activation

Jeremy Goh, Denise Manahan-Vaughan¹

¹Ruhr University Bochum, Department of Neurophysiology, Universitätsstraße 150, 44780 Bochum, Germany

The hippocampus is thought to play a major role in the formation of spatial memories and a debated role in object recognition. This study sought to clarify the synaptic changes that occur at the electrophysiological and mechanistic levels in response to object recognition in freely behaving mice. Each adult mouse was chronically implanted with a recording electrode in the CA1 stratum radiatum and a stimulating electrode in the afferent Schaffer collaterals. Following a recovery period from surgery, behavioral tasks with concurrent electrophysiological recordings were commenced. It was shown here that object recognition triggers LTD at the CA1 synapses. The synaptic response was shown to be an effect of learning about object-space novelty rather than object novelty per se. Successful novelty detection of such nature, both at the behavioral as well as the electrophysiological level, was further shown to be dependent on the activation of both the NMDA as well as mGlu5 receptors. The data suggests for a spatial component in object recognition, whereby changes to any component of the object-space unit constitutes novelty and induces LTD in the CA1. A consequential relation between behavioral learning of the tasks and the corresponding synaptic changes was further proved through the pharmacological antagonism of the NMDA and mGlu5 receptors. Moreover, the finding that learning-facilitated plasticity occurs in mice adds to earlier reports of its existence in rats. This suggests that learning-facilitated plasticity is a synaptic property that is shared by multiple species, hence granting ascendancy to its plausibility as a memory mechanism.

APIS – a novel system for automatic conditioning of honey bees

Nicholas Hagen Kirkerud, David Gustav¹, Henja-Niniane Wehmann¹, C. Giovanni Galizia¹

¹University of Konstanz, Department of Biology, Neurobiology,
Universitätsstraße 10, 78457 Konstanz, Germany

For more than 50 years, honeybees have been widely used model organisms for the study of learning, memory and the underlying neuronal substrates and mechanisms because they combine a rich behavioral repertoire with an easily accessible brain of 1mm³ in size. The well-established Proboscis Extension Response-paradigm (PER, see Sandoz & Giurfa 2012 for an overview) has been used to quantify appetitive learning in nectar feeding insects for decades. Recently, an aversive paradigm based on Sting Extension Response (SER) to electric shocks has been developed (Vergoz et al. 2007). These methods, in which the bees are harnessed, are technically challenging, vary to different extents from lab to lab, and have relatively high statistical restraints because of the binary data they produce.

Here we introduce a novel method of honeybee conditioning: APIS, the Automatic Performance Index System. In an enclosed walking arena where the interior is covered with an electric grid, the bee is presented with odors from either end coupled with weak electric shocks to form aversive associations. The movement of the bee and its responses to the stimulus as well as to the electric shocks are monitored continuously by an automatic tracking system. From the tracking data output, several factors of the bee's behavior in the chamber - like increase in activity, turning reaction time, and time and distance spent away from punished odor - can be used to calculate a new index accessing the individual bee's learning ability – the BeeQ.

Our data shows that the average BeeQ in a population correlates well with average learning indices obtained from conventional PER-conditioning. Thus, the advantages of this automatic system makes it ideal for assessing learning rates in a standardized and convenient way, and its flexibility adds to our toolbox for studying mechanisms behind learning and memory.

Age-dependent impact of avoidance pretraining on adult learning: functional imaging in freely behaving mice

Almuth Spröwitz, Anett Riedel¹, Jörg Bock¹, Katharina Braun¹

¹Otto von Guericke University, Institute of Biology, Zoology/Developmental Neurobiology, Magdeburg, Germany

Cognitive training during infancy is critically involved in shaping neural circuits and thereby determines learning capacity later in life. Using a two-way active avoidance paradigm we have shown that avoidance learning in infant or periadolescent mice (three to five weeks old) is attenuated compared to adult mice. In adulthood the mice pretrained at age of six weeks showed better avoidance performance compared to non pretrained adults. In contrast, avoidance learning in adult mice which were pretrained at the age of three weeks was strongly impaired.

Functional imaging using 2-Fluoro-deoxy-glucose (2-FDG) autoradiography was applied in order to identify the differences in brain activation, which underlie the improved/impaired adult avoidance learning. The following animal groups were analyzed: i) adults pretrained at the age of three weeks (= early pretraining group, EP), ii) adults pretrained at the age of six weeks (= late pretraining group, LP) and iii) non pretrained adults (NP). 14 brain regions were identified according to their activation patterns. In the EP group the hippocampus showed a significantly reduced metabolic activity compared to the NP and LP groups. Moreover, the analysis of correlated activity within the identified brain circuits revealed significantly different co-activation patterns in the three experimental groups.

Taken together, the behavioral and functional imaging data indicate that pretraining during infancy alters learning-evoked neuronal plasticity during adult learning performance. The LP group retrieves the learned information from pretraining and thereby optimizes adult avoidance learning. In contrast, the EP group may have developed symptoms of „learned helplessness“ during infant pretraining and thus maintain their escape strategy, which blocks the acquisition of an avoidance strategy.

A walking simulator for studying aversive classical and operant conditioning in honeybees

Florian BASTIN, Andreas S. Brandstaetter¹, Jean-Christophe Sandoz¹

¹CNRS Gif-sur-Yvette, Laboratoire Evolution, Génomes et Spéciation, Avenue de la Terrasse, 91198 Gif-sur-Yvette, France

Animals usually have no a priori knowledge about their environment and need to adapt their behavior appropriately in order to survive. In the context of foraging, for instance, animals have to learn where to find profitable food sources (appetitive learning) and how to avoid dangers (aversive learning). Theoretically, such associative learning can be divided into two main types, depending on what animals learn. In *classical* (Pavlovian) conditioning, animals learn to associate a stimulus from the environment with a reinforcer. In *operant* (instrumental) conditioning, animals learn to associate their own behavior with a reinforcer. In nature, however, most learning situations comprise both classical and operant components, and it is often difficult to discern which associations an animal actually made. To understand the mechanisms and rules of classical and operant learning, it is necessary to study both types of conditioning under otherwise similar, controlled experimental conditions. The honeybee *Apis mellifera* is a standard insect model for studying mechanisms of learning and memory. Laboratory assays for studying appetitive and aversive classical conditioning in honeybees are well established. For operant conditioning, however, experimental procedures in the laboratory are still scarce. In addition, there is no behavioral laboratory assay so far, which allows studying both classical and operant conditioning in the same experimental setup. To overcome this limitation, we developed a walking simulator based on a locomotion compensator and studied classical and operant learning in an aversive context.

Tethered honeybees were placed on an air-supported Styrofoam ball. Ball movement was monitored and by this the bees' walking behavior could be precisely measured. In classical conditioning, the experimental arena was illuminated in turn with green and with blue color and illumination with one color was coupled to heat punishment with an IR laser aimed at the upper abdomen of the bee. In the test, punishment was switched off and the bees were allowed to control the color of arena illumination by turning in the walking simulator. Workers spent significantly more time in the unpunished than in the punished color illumination and, thus, learned to associate color with punishment (*classical learning*). In operant conditioning, punishment was coupled with the workers' turning direction (left or right). During the test, workers avoided turning into the punished direction and turned more often into the unpunished direction. Honeybees are, thus, able to associate their own turning behavior with punishment in our experimental setup (*operant learning*). In a third experiment, we tested which type of learning honeybees will use, if given the choice between classical and operant rules. During conditioning, both a color and a turning direction were coupled with punishment (double conditioning). In the test, workers significantly avoided 1) the punished color and 2) turning into the punished direction at group level. Individual bees, however, were rarely using both learning rules at the same time: most bees avoided either the punished color or turning into the punished direction and, hence, relied on either the classical or the operant learning rule. This experimental setup will be coupled with pharmacological injections and neurophysiological recording techniques to study the neural processes underlying operant and classical learning in the bee brain.

Ionic current modulations of honeybee antennal lobe and mushroom body neurons

Sophie Himmelreich, Bernd Grünewald¹

¹Goethe University Frankfurt, Institute for cell- and neurobiology, Max-von-Laue-Straße 13, 60438 Frankfurt, Germany

The honeybee (*Apis mellifera*) is a model organism for the study of learning and memory formation and its underlying cellular mechanisms. The neuronal pathway for associative olfactory learning includes two neuropils: the antennal lobes and the mushroom bodies. Here, the excitatory cholinergic pathway and the octopaminergic reward pathway converge. For learning-related plasticity, the coincident occurrence of the conditioned stimulus (CS) and the reward (unconditioned, US) has to be detected by the nervous system.

We performed patch-clamp recordings and cell calcium (Ca^{2+})-imaging to investigate the cellular interactions of the nicotinic acetylcholine receptor (nAChR) system and the octopamine receptor system of antennal lobe neurons and mushroom body intrinsic Kenyon cells *in vitro*.

Patch-clamp experiments showed ACh-induced excitatory currents in antennal lobe and Kenyon cells. Co-application of ACh and biogenic amines (10 μM octopamine or 10 μM serotonin) revealed reversibly decreased currents. Also currents in antennal lobe neurons were reduced by co-applications of ACh and the adenylyl cyclase activator forskolin (10 μM). This indicates involvement of a cAMP-dependent signaling cascade.

The Ca^{2+} -imaging experiments have shown that biogenic amines (octopamine and serotonin, both 1 μM) evoked Ca^{2+} -transients in antennal lobe neurons and Kenyon cells. Octopamine-induced transients were blocked by the antagonist mianserin (100 μM). Co-applications of ACh (100 μM) and the two biogenic amines octopamine and serotonin (both 1 μM) reduced Ca^{2+} -signals. The same was observed during co-applications of ACh and forskolin (10 μM).

Due to these findings, we postulate two possible cellular coincidence detectors between the cholinergic CS pathway and the reward (US pathway) during olfactory learning. These detectors may modulate further the incoming stimuli: (1) The activation of a calcium Ca^{2+} -dependent kinase which may be activated by an elevated intracellular Ca^{2+} -concentration induced by the coincident activation of the nAChR and an α -adrenergic-like octopamine receptor, AmOA1. (2) The possible phosphorylation of the nAChR by a cAMP-dependent protein kinase (PKA) triggered by β -adrenergic-like octopamine receptor activation. Both assumptions would lead to modulations of ACh-induced ionic currents as observed in our experiments. They may indicate coincidence mechanisms during olfactory learning. But further studies have to be done to unravel coincidence detectors between the US and CS.

Physiological mechanisms of sensory augmentation assessed by fMRI

Johannes Keyser, Susan Wache¹, Maria Schmitz¹, Sebastian Fleck¹, Sabine U. König¹, Robert Muil¹, Saskia K. Nagel¹, Frank Schumann¹, Thomas Wolbers^{2,3}, Christian Büchel², Peter König^{1,4}

¹Institute of Cognitive Science, Universität Osnabrück

²Institute of Systems Neuroscience, University Medical Center Hamburg Eppendorf

³German Center for Neurodegenerative Diseases, Magdeburg

⁴Department of Neurophysiology and Pathophysiology, University Medical Center Hamburg Eppendorf

Enacted theories of consciousness conjecture that perception and cognition arise from an active experience of the regular relations that tie together sensory stimulation and associated motor actions. In a previous experiment we investigated perceptual and behavioural changes induced by a sensory augmentation device [1]. Here we investigate the physiological substrate of these changes.

A specially designed belt mapped directional information measured by a compass to a set of vibrators by activating the element pointing north. Out of 14 subjects 9 wore the belts during all waking hours over a period of seven weeks. In two fMRI sessions, before and after the training period, we presented a virtual path integration task and a control task with identical perceptual input [2]. Participants travelled passively along two legs of a triangle before pointing towards the starting location. In both tasks we compared *belt on/off* conditions of *belt-wearers/control subjects*. Behavioural and imaging data of the resulting 2x2x2x2 design were analysed by ANOVAs.

Our findings are:

- Behavioural pointing performance did not improve through belt training. This matches the subjects' reported inability to transfer and apply the belt's information to the path integration task.
- The main effect *path integration > control task* reveals large-scale differences, for example in supplementary motor areas (SMA), precuneus, and occipital, parietal inferior, and middle frontal cortices (see figure, green coloured contrast). This demonstrates that subjects handle both tasks differently.
- The main effect *belt-wearers/control subjects* results in activations in right hippocampus and right frontal inferior operculum.
- The main effect *pre/post training* indicates activation in right SMA and right precentral gyrus.
- The main effect of *belt on > off* reveals processing of the tactile signal in expected sensory areas such as the postcentral gyri, supramarginal gyri and Rolandic opercula (cf. figure, red coloured contrast).
- Out of the six two-way interactions we highlight the contrasts including the factor *belt on/off*. The two-way interaction between *belt on/off* and *pre/post training* is located in the postcentral gyri,

middle temporal lobules and right parietal superior lobule (see figure, blue coloured contrast). Inspection of the activation intensities suggests a larger *belt on* > *off* difference in the *pre*- than in the *post*-measurement.

- The two-way interaction *belt-wearers/control subjects* and *belt on/off* reveals differential activation of the left SMA and left middle temporal lobe.
- The two-way interaction *path integration/control task* and *belt on/off* includes right precuneus, right frontal superior lobe and left postcentral gyrus.

In summary, we observe differential activations well beyond the somatosensory system, specifically including areas of the motor system and superior parietal lobule, compatible with embodied theories of cognition. Further analyses have to elucidate the properties of these and higher order interactions.

1. Nagel, S.K., Carl, C., Kringe, T., Martin, R., and König, P. (2005). Beyond sensory substitution – learning the sixth sense. *J. Neural Eng.* 2, R13-R26.
2. Wolbers, T., Wiener, J. M., Mallot, H. A., & Büchel, C. (2007). Differential Recruitment of the Hippocampus, Medial Prefrontal Cortex, and the Human Motion Complex during Path Integration in Humans. *The Journal of Neuroscience* 27(35).

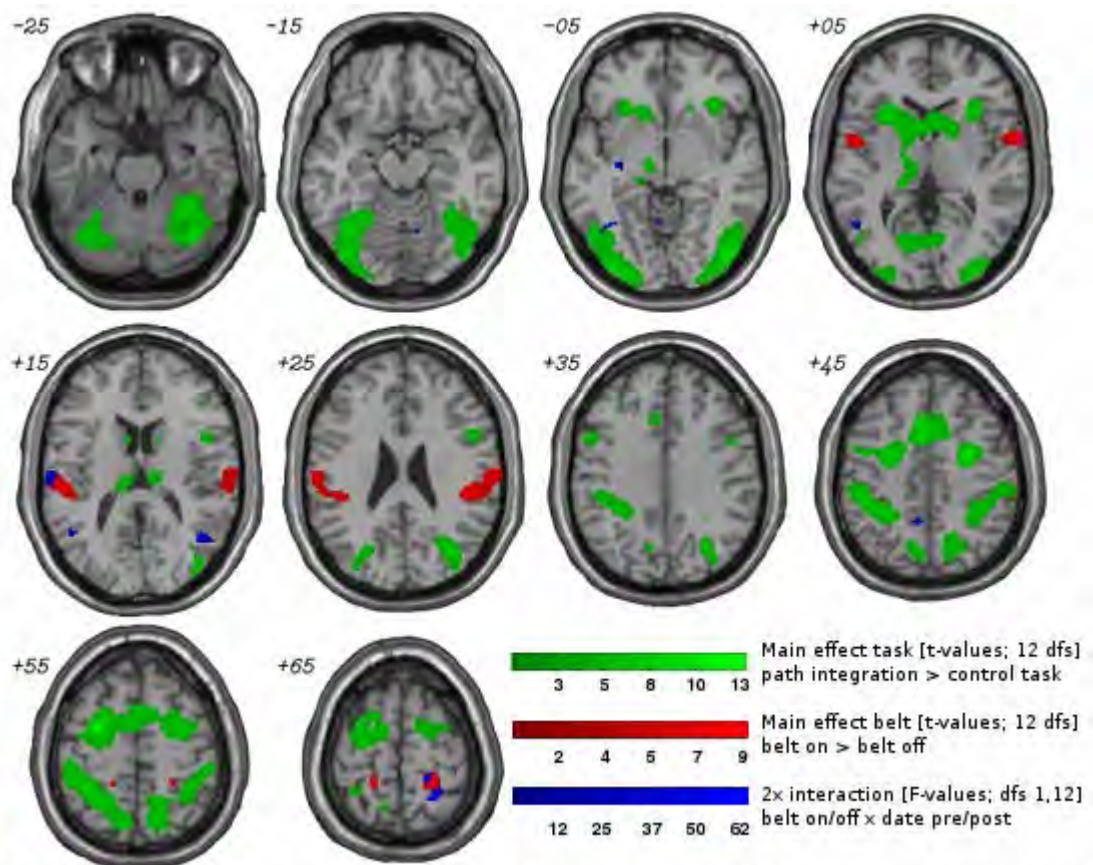

Axial slices through canonical MNI T1-image, all contrasts thresholded at $p < 0.001$, uncorrected

Effects of glutamate in intra- and extracellular recordings from mushroom body extrinsic neurons in the honey bee

Ruth Bartels, Stefan Voigt², Randolph Menzel^{1,3}

¹Freie Universität Berlin, Neurobiologie, Berlin, Germany ²Universität Potsdam, Germany ³Bernstein Center for Computational Neuroscience (BCCN) Berlin, Germany

In insects the mushroom body (MB) has been shown to be crucial for processing of sensory information, learning and formation of memory. A major limitation in analyzing the function of the MB is the lack of knowledge about the transmitters of MB intrinsic neurons, the Kenyon cells. Immunocytochemistry revealed a range of small peptides, serotonin, taurine and glutamate. Kenyon cells converge onto extrinsic neurons in the α -lobe. We combine extra- and intracellular recordings from extrinsic neurons (EN) with pharmacological manipulations. We found decreases in spontaneous activity after glutamate injection in ENs. Furthermore, we saw increases of spontaneous activity when manipulating NMDA-like receptors. Thus, glutamate has an effect on MB extrinsic neurons. In order to investigate the role of glutamate, we also perform experiments in which we combine the glutamate injections with either direct stimulation or indirect stimulation of Kenyon cells using stimulation electrodes or odor presentation, respectively.

Heterogenous populations of amygdala medial paracapsular intercalated cells receive presynaptically - modulated sensory inputs

Douglas Asede, Daniel Bosch¹, Francesco Ferraguti³, Ingrid Ehrlich¹

¹Centre for Integrative Neuroscience / Hertie Institute for Clinical Brain Research, Physiology of Learning and Memory, Otfried-Müller-Str. 25, 72076 Tuebingen, Germany

²Graduate School of Neural and Behavioural Sciences, IMPRS, Tübingen, Germany

³Department of Pharmacology, Innsbruck Medical University, Innsbruck, Austria

Characterization of amygdala circuits is important for understanding fear behavior. During fear learning, sensory information from specific thalamic (T) and cortical (C) regions is relayed to neurons in the lateral amygdala (LA). The innervation and its plasticity onto principal, glutamatergic neurons has been thoroughly investigated, but the contribution of inhibitory mechanisms is still poorly understood. GABAergic intercalated neurons (ITC) that surround the BLA in distinct clusters are activated differentially during high and low fear states. Furthermore, medial cluster (mp)-ITCs are more heterogenous than previously thought as individual cells have distinct targets both intrinsic and extrinsic to the amygdala. Here, we address two questions: (1) Are mp-ITCs innervated by sensory fibers and what are their functional properties? (2) Are there putative novel targets of mp-ITCs for inhibitory control within the amygdala?

Using a combination of tracing, electrical stimulation, optogenetics, and patch clamp recordings in brain slices of adult mice, we first investigated sensory inputs. We show that mp-ITCs receive monosynaptic sensory T and C inputs. These inputs are glutamatergic, and mediated by AMPA- and NMDA-receptors. Interestingly, both T and C inputs are presynaptically modulated by metabotropic mechanisms. Application of GABA(B)- and group III mGlu-receptor agonists suppressed EPSCs, with a concurrent increase in paired pulse ratio. These effects were reversed by specific antagonist applications. Physiological activation of the mp-ITC network by priming either T or C afferents with high frequency stimulation, resulted in presynaptic inhibition of the other pathway, which was blocked by a GABA(B)-receptor antagonist. This suggests that sensory inputs to mp-ITC cells are under presynaptic modulatory control by the mp-ITC intrinsic GABAergic network.

To assess outputs of mp-ITCs, we filled cells during recording and subjected them to histological analysis. Based on axonal projection patterns, we found three distinct mp-ITC types in accordance with previous studies. In addition, we identified a novel cell type with significant axonal arbors in the BLA establishing inhibitory synaptic contacts with dendritic shafts (probably of BLA-principal cells). This suggests that mp-ITCs could participate in sensory feed-forward inhibition to the BLA. Taken together, our results describe novel inputs and outputs of mp-ITCs that extend and challenge the classical view of ITC function in amygdala networks.

Pattern separation in the human hippocampus

David Berron, Hartmut Schütze¹, Emrah Düzel^{1,2,3}

¹Otto-von-Guericke-University Magdeburg, Institute of Cognitive Neurology and Dementia Research, Magdeburg, Germany

²University College London, Institute of Cognitive Neuroscience, London, United Kingdom

³German Center for Neurodegenerative Diseases, Magdeburg, Germany

The ability to distinguish among similar experiences is crucial for episodic memory. Computational models propose this ability to depend on pattern separation, a process which is needed to rapidly store distinct memory representations within the hippocampus. Furthermore, recent neuroimaging studies could highlight the importance of the hippocampus and especially the dentate gyrus and CA3 region to perform pattern separation.

Here we investigated hippocampal pattern separation during a memory task where subjects had to discriminate original stimuli from similar appearing lures. Stimuli were quasi-realistic images of different indoor scenes and were presented in an event-related design.

We used 7 T ultra high-field functional magnetic resonance imaging and a functional resolution of 0.8 mm isotropic voxels to assess pattern separation processes at the level of hippocampal subfields. Univariate and multivariate analyses were applied and preliminary results confirm the importance of the dentate gyrus and CA3 region during pattern separation.

Taken together, this approach can provide insights into the neural representations that underlie pattern separation processes within hippocampal subfields.

Testing *Drosophila* learning and memory mutants with and without methylphenidate treatment in Buridan's paradigm

Yasmine Jennifer Graf, Bjoern Brembs¹

¹Institut für Neurobiologie, Freie Universität Berlin, AG Brembs, Königin-Luise-Straße 28-30, 14195 Berlin, Germany

Activity is one of the most important and complex traits animals have evolved. Exploration and foraging behavior are indispensable to life of all groups of insects and thus for the fruit fly *Drosophila melanogaster*. One very important component of the flies' activity are visual processes which are demonstrably affected by particular learning and memory mutations (van Swinderen et al., 2009). Interestingly recent studies showed that one of the mutants, *radish* can be rescued by a methylphenidate treatment whereas others cannot (van Swinderen & Brembs, 2010). To investigate which parts of activity are in detail affected by the mutations and/or the drug treatment Buridan's paradigm was used. As a result of this detailed activity analysis the present study gives evidence that it is not forcing activity in general that can be changed by this particular pharmacological treatment but one important part of it: time activity.

Characterization of mPFC inputs to principal neurons and interneurons in the basolateral amygdala

Cora Hübner, Daniel Bosch¹, Andreas Lüthi³, Ingrid Ehrlich¹

¹ HIH/CIN, Tübingen, Germany

²Graduate School of Neural and Behavioral Sciences, IMPRS, Tübingen, Germany

³ Friedrich Miescher Institute, Basel, Switzerland

The amygdala is a key brain structure for processing and storing of fear memories. However, an interconnected circuit comprising the basolateral amygdala (BLA), hippocampus, and medial prefrontal cortex (mPFC) participates in encoding different aspects of fear and extinction learning and memory. Behavioral pharmacology, activity mapping studies and in vivo recordings from unidentified neurons report that subregions of the mPFC have contrary roles during fear and extinction. While the prelimbic region (PL) shows enhanced neural activity in high fear states, the infralimbic cortex (IL) is implicated during acquisition, consolidation and retrieval of extinction. Thus, IL and PL can interact with the amygdala, in particular the BLA, and by virtue of their reciprocal connections influence fear outcome. Currently, the cellular and synaptic interactions between specific mPFC regions and their targets in the BLA are poorly understood.

Using an optogenetic approach, we started to investigate the synaptic properties of long-range inputs from the mPFC to distinct amygdala neurons in the basal amygdala (BA). We express tDimer-tagged Channelrhodopsin-2 in mPFC subregions via viral-mediated gene transfer in vivo. Projections are visualized and light-activated in acute amygdala slices ex vivo, while patch-clamp recordings are obtained from identified BA neurons.

We find that a fraction of BA principal neurons (PN) and interneurons (IN) receive synaptic inputs from the mPFC and are spatially intermingled with non-responding cells in the BA. All responding neurons show an early, monosynaptic excitatory component, while 15% of PNs and 23% of INs also show suprathreshold actionpotentials. Furthermore, we detect delayed inhibitory inputs, presumable mediated by feed-forward inhibition in both PNs (15% of inputs) and INs (8% of inputs). Preliminary results suggest that properties of excitatory and inhibitory inputs to PN and IN have different kinetics and components, respectively. Our goal is to further analyze which subpopulations of BA interneurons receive which types of inputs from subregions of the mPFC.

The characterization of the different SAP47 isoforms

Jörg Kleber, Timo Saumweber¹, Sören Diegelmann¹, Bertram Gerber¹

¹Leibniz-Institute for Neurobiology, Genetics of Learning and Memory, Brenneckestr. 6, 39118 Magdeburg, Germany

The brain is the most complex organ that evolved during evolution. Its function is to enable the organism to act and react in a complex environment. One of the main functions is to allow the organism to learn and to remember. The aim of neurobiology is to gain inside into the processes which takes place during these interactions between the brain and the outside world e.g. to understand how learning and memory takes place on a cellular and molecular level. Many proteins play an important role in these memory and learning processes.

In my ongoing study I focus on the synapse-associated protein of 47 kDa (SAP47). This protein was identified in *Drosophila* by a monoclonal antibody screen from a hybridoma library. Homolog sequences of a highly conserved BSD domain within the protein can be found in other insects as well as in plants and humans. Beside this little is known about other protein domains involved in synaptic function. In *Drosophila* the genomic region has a size of 25 kb. Via alternative splicing eight mRNA isoforms are predicted. In larval behavior study Saumweber et al. (2011) showed that flies lacking Sap47 expression are impaired in associative learning. This phenotype could be rescued by expressing a SAP47 isoform specific construct, whereas a second construct different in exon and UTR structure could not. This observation guided me to two topics: i) which isoforms are present in 3rd instar larvae and/or in adult flies and ii) which domains are important for rescuing the learning impairment.

To this point I could show a specific mRNA isoform expression pattern in the larva and adult fly. Whereas some isoforms are present in both development stages, there are also specific isoforms only detectable in the adult stage. Using antibodies raised against specific epitopes of the different isoforms, I hope to determine the cellular distribution of the different SAP47 variants. To address the second topic I started to generate SAP47 rescue constructs which differ only in the presence or absence of specific exons and UTR. By performing behavioral experiments in larval animals I want to test for the ability to rescue the learning impairment.

With this study I hope to generate a more detailed view into the expression pattern of the different SAP47 mRNA isoforms. My behavioral investigations with several transgenic constructs will help to reveal important SAP47 domain structures involved in behavior and learning. With this work I hope to contribute to the understanding of how memory and learning processes take place on the molecular and cellular level.

Towards the Biochemical Components of the Visual Orientation Memory in *Drosophila*

Sara Kuntz, Burkhard Poeck¹, Roland Strauss¹

¹Johannes Gutenberg-University Mainz, Department of Zoology III - Neurobiology, Col.-Kleinmann Weg 2, 55099 Mainz, Germany

Living in a complex environment requires goal-driven behaviour like path planning and recall for orientation. In order to navigate in the proper direction, *Drosophila melanogaster* flies memorize the path towards a target even when the target gets temporarily out of sight. Moreover, they use idiothetic information to recall their former orientation towards an object even after a detour to resume their initial approach. Recent studies have shown that walking flies possess a visual orientation memory for attractive targets that is localized in the ellipsoid body of the central complex in the adult fly brain (Neuser et al., 2008). The present study analyses the signalling pathway necessary for this type of working memory. We therefore tested different strains defective in learning and memory, for instance the *foraging* (*for^S*) mutant. *for^S* is a natural polymorphism and affects larval food-search strategies and has recently been implicated in conditioned learning and memory (Sokolowski, 2001). Here we show that the cGMP-dependent protein kinase (PKG) encoded by *for* is required for the visual orientation memory. Differential rescue experiments using the UAS/GAL4-system (Brand and Perrimon, 1993) unravelled the necessity for PKG in just one of four known types of ellipsoid-body ring neurons (R3). The same set of R3 ring neurons has previously been shown to require *ignorant* (*ign^{58/1}*) to bring about the visual orientation memory (Neuser et al., 2008). *ign* encodes the fly orthologue of Ribosomal-S6 Kinase 2 (RSKII) and *ign^{58/1}* mutants show deficits in other associative and operant learning paradigms (Putz et al., 2004). Genetic and epistatic interaction studies provide evidence that the FOR kinase functions upstream of the IGN kinase, thus revealing a novel neuronal signalling pathway necessary for this type of working memory in *Drosophila* (Kuntz et al., 2012). Furthermore, cell-type specific knockdown of the *rutabaga* adenylyl cyclase suggests that the cAMP-level in the ellipsoid-body ring neurons is also critical for the orientation memory. It remains to elucidate how these kinases interact with the cAMP signalling pathway to enable the ring neurons to establish a visual orientation memory.

This work was supported by a PhD stipend to S.K. from the Stipendienstiftung Rheinland-Pfalz and by the German Science Foundation DFG grant no. STR590/2-4.

References

- Brand and Perrimon (1993): Targeted gene expression as a means of altering cell fates and generating dominant phenotypes. *Development*. 118(2): 401-415.
- Kuntz et al. (2012) The visual orientation memory of *Drosophila* requires Foraging (PKG) upstream of Ignorant (RSK2) in ring neurons of the central complex. *Learning & Memory*. 19: 337-340.
- Neuser et al. (2008): Analysis of a spatial orientation memory in *Drosophila*. *Nature*. 453(7199): 1244-1247.
- Putz et al. (2004): The S6KII (*rsk*) gene of *Drosophila melanogaster* differentially affects an operant and a classical learning task. *The Journal of Neuroscience*. 24(44): 9745-9751.

Sokolowski (2001): *Drosophila*: Genetics meets behaviour. Nature Reviews Genetics 2(11): 879-890.

High-voltage activated Ca²⁺ channels in septohippocampal theta genesis

Anna Papazoglou, Magdalena, Elisabeth Siwek¹, Christina Henseler¹, Ralf Müller², Karl Broich¹, Marco Weiergräber¹

¹Federal Institute for Drugs and Medical Devices (BfArM), Cellular and Systemic Neurophysiology, Kurt-Georg-Kiesinger Allee 3, 53175 Bonn, Germany

²Department of Psychiatry and Psychotherapy, University of Cologne, Kerpener str.62, 50931 Cologne, Germany

Voltage-gated Ca²⁺ channels are key elements in neuronal excitability related to synaptic transmission, somatodendritic integration and information processing. Septohippocampal theta oscillations correlate with various cognitive and behaviorally related processes and can be differentiated pharmacologically into atropine-sensitive type II and atropine-insensitive type I theta. The mechanisms of type II and type I theta genesis have been a question of debate for long including both the muscarinic signal transduction pathway and NMDA mediated processes. Using molecular studies and in vivo implantable video-EEG radiotelemetry in mice we analyzed the role of high-voltage activated Ca²⁺ channels in the initiation and maintenance of hippocampal theta oscillations. For this purpose, a new wavelet-based computational approach for detecting highly synchronized theta oscillations has been developed. Our results provide new insight into septohippocampal rhythmicity related to theta activity.

Thermo-genetic induction of a memory trace in subsets of *Drosophila* mushroom body Kenyon cells

Thomas Dieter Riemensperger, David Vasmer¹, Atefeh Pooryasin¹, Silke Dempewolf¹,
Hendrik Urbanke¹, André Fiala¹

¹Georg-August-Universität, Johann-Friedrich-Blumenbach-Institut, Neurobiology of Behavior, Julia-Lermontowa-Weg 3, 37077 Göttingen, Germany

Associative learning can be considered as a simple form of memory formation, in the course of which an animal through perception of punishing or rewarding stimuli assigns values to naïvely neutral stimuli. Thereby, the animal adjusts its behavioral response to the predicted consequences. The *Drosophila* mushroom bodies are crucial brain centers for olfactory associative learning and memory. Genetic, as well as anatomic and physiological studies have led to the concept of a representation of the odor environment as a « sparsed code » in the mushroom body Kenyon cells of the fly. Information of simultaneously perceived punishing or rewarding events are mediated through aminergic neurons, that innervate the mushroom body lobes. Odor information and punishing or rewarding stimuli are integrated at this site. Recent studies could strengthen this model by revealing that opto-genetic or thermo-genetic activation of distinct modulatory neurons with simultaneous odor stimulation induces an appetitive or aversive odor memory. On the contrary, it has remained by now impossible to conversely simulate an odor stimulation through artificial activation of ensembles of Kenyon cells in order to test whether simultaneous presentation of electric shocks together with an artificial activation of these cells is sufficient to provoke memory formation. The reason for this relies on the sparse character of olfactory information at the level of Kenyon cells. Using the thermo-inducible cation channel dTRPA1 we artificially induce activity of random patterns of Kenyon cells and demonstrate that these ensembles are sufficient to elicit a learned behavioral output in the absence of odor stimulation.

Single-neuron photoactivation via recombinase-mediated cell-specific expression of Channelrhodopsin-2, to analyze habituation in sensory neuronal circuits

Cornelia Schmitt, Jana Liewald^{1,2}, Sebastian Wabnig^{1,2}, Alexander Gottschalk^{1,2}

¹Buchmann Institute of molecular life sciences, Johann Wolfgang Goethe University Frankfurt am Main, Germany

²Institute of Biochemistry, Johann Wolfgang Goethe University Frankfurt am Main, Germany

Habituation is a simple form of non-associative learning, in which multiple repetitions of a stimulus cause a reduction in the response. Habituation of the *C. elegans* withdrawal reflex in response to gentle touch or a tap of the culture dish is well characterized. Yet, only little is known about the (molecular) mechanisms of habituation and the exact focus where habituation is effected within the signalling cascade leading to withdrawal. This could occur at the level of the primary sensory receptor molecules, signalling within the sensory neurons, at their output synapses or in the downstream interneuron network.

Previously, we and others showed that Channelrhodopsin-2 (ChR2) mediated in vivo stimulation of mechanosensory neurons can induce withdrawal behaviour and habituation [1, 2]. To this end, we expressed ChR2 in touch neurons. Expression of ChR2 in the downstream ('backward') command interneurons, i.e. AVA and AVD cells, is also expected to induce withdrawal behaviour. However, promoters active in these cells are not highly specific, thus the optogenetic stimulation would also affect other cells. To achieve highly specific activation of ChR2 in single neurons (like AVA and AVD) we use the cre-lox system, which was recently introduced for *C. elegans* [3]. This method provides the ability to use two different promoters for gene expression, with expression patterns that include the cell of interest, but no additional overlap in other cells in which each promoter may be active [4].

We will show which neurons in the withdrawal pathway (touch sensory neurons, chemosensory neuron ASH, interneurons AVA and AVD) will or will not habituate and find out where the learning modulation happens. Also, we will take a closer look at the command interneurons AVA and AVD, as well as the mechanosensory neurons and ASH: What types of synapses are involved in evoking or processing the withdrawal behavior? Chemical or electrical transmission? To identify the transmitters involved, we will use cell-specific knockdown of the respective biosynthetic enzymes or vesicular transporters, or of the respective receptors at the post-synaptic side. We will further measure the signals arriving at body wall muscles via electrophysiology and Ca²⁺-imaging.

1. Nagel, Brauner, Liewald, Adeishvili, Bamberg and Gottschalk (2005) *Curr. Biol.* 15: 2279-2284
2. Stirman, Crane, Husson, Wabnig, Schultheis, Gottschalk and Lu (2011) *Nature Methods* 8: 153-158
3. Macosko, Pokala, Feinberg, Chalasani, Butcher, Clardy and Bargmann (2009) *Nature* 461: 1171-1175
4. Schmitt, Schultheis, Pokala, Husson, Liewald, Bargmann and Gottschalk (2012) *PLoS One* 7: e43164

Population clock models and delayed temporal memory: An information theoretic approach

Sakyasingha Dasgupta, Florentin Wörgötter¹, Poramate Manoonpong¹

¹Bernstein Center for Computational Neuroscience, Georg-August-Universität Göttingen, Department for Computational Neuroscience, Friedrich-Hund Platz 1, 37077 Göttingen, Germany

The ability to precisely track and tell time is critical towards the learning of ordered motor behaviors as well as the underlying cognitive process, in all living creatures. However, the mechanism by which the brain tells time is still not understood clearly. Although it is still debated whether dedicated or intrinsic mechanisms underlie the timing process, some experimental and theoretical studies have validated the concept of neural circuits being inherently capable of sensing time across time scales. Large recurrent neural networks could be considered as an abstraction of the mammalian cortex. Accordingly Buonomano and Laje, 2010 suggested that population clocks, where in time is encoded in the time varying patterns of activity of neuronal populations emerge from the internal dynamics of the recurrent network. Furthermore in order to account for varying time-scales of input patterns to such networks, classically they have been arranged in hierarchies of networks with different timescales. However monkey experiments (Bernacchia et. al,2011) have shown that individual neurons can have different timescales of reward memory correlated with the actual behavior. As such it is highly plausible that neurons in a single recurrent network can adjust their individual time constants to account for a multi-timescale input in contrast to a hierarchical arrangement with different fixed timescales.

In this work, we describe a single information theoretic framework for adapting the local neuron time constants via its leak. The recurrent neural network is composed of leaky-integrator neurons, where in, the individual neuronal leak-rate governs the dependence of the current activity of the neuron on the actual net input to it, compared to its own previous activity. This is adjusted by an active information storage(AIS) measure at each spatial-temporal location of a recurrent neural network. This quantity measures the amount of information in the previous state of the neuron that is relevant in predicting its future state. Interestingly high AIS regions in the network correspond to significant events in time. Depending on whether this measure is either greater or less than a pre-defined threshold, the leak control parameter is adjusted accordingly with the inverse of this control parameter determining the leakage rate of each neuron. In other words we are able to incorporate a self-adapting non-uniform leak rate in the network that can account for varying timescales in the input stream as well as encode timing of events. Furthermore we combine this with a mutual information driven intrinsic plasticity scheme in order to homeostatically control runaway or highly chaotic activity in the network. We test our network on a physical six legged walking robot for a delayed memory T-maze navigation task. This requires the correct maintenance of variable time delays between turning cue to the robot and the point of memory recall at the T-junction. This mechanism effectively copes with variable time delays (#different T-maze size) and demonstrates that time is not only encoded in the internal recurrent dynamics but also single neurons can adjust their time-constants in order to account for high relevance events in the input data.

References

1. Buonomano V. D. and Laje R. (2010) Population clocks: motor timing with neural dynamics. Trends in Cognitive Sc. 14, 520-527
2. Bernacchia A., Seo H., Daeyeol L. and Wang X. (2011) A reservoir of time constants for memory

traces in cortical neurons. *Nature Neuroscience*. 14, 366-372.

3. Lizier J.T., Prokopenko M. and Zomaya A.Y. (2012) Local measures of information storage in complex distributed computation. *Information Sciences*. 208, 39-54

Learned Helplessness in *Drosophila*

Zhenghong Yang, Reinhard Wolf¹, Martin Heisenberg¹

¹Rudolf-Virchow-Zentrum, AG Heisenberg, Josef-Schneider Str. 2, Haus D15, 97080 Würzburg, Germany

Single flies are kept in a small box (2x4x28mm) where their position is continuously monitored and their temperature is manipulated. Flies walk or rest. There are three groups, 'Master', 'Yoked' and 'Control' flies. For Master and Yoked the ground temperature is 24°C but they can instantaneously be heated to 37°C. Control flies have 27°C throughout. The experiment consists of three phases, a 1/2min pretest, 10min training and a 1/2min test. A Master fly is heated if it stops walking for >1 sec. Heat turns off immediately if it resumes walking. The corresponding Yoked fly receives the same temporal sequence of heat/no-heat but cannot influence it.

Flies have a high initial walking activity and gradually reduce it during training. The reduction is largest for Yoked flies. Paradoxically, Master flies increase the frequency of stops >1 sec but not those <1 sec as compared to Yoked and Control flies. However, stops >1 sec are much shorter than in Yoked flies. In the subsequent test without heat the number of stops >1 sec is the same for all three groups but in Yoked flies they last much longer than in Master and Controls. Many short stops (>1 sec) seem to be a compromise for Master flies to still get enough rest while keeping heat punishment low. The long rest periods of Yoked flies, even in the test without heat, could be due to "learned helplessness" as proposed by Brown et al. (1996; Psychological Report 78: 962).

Operant conditioning of *Drosophila* in the Shockbox

Sophie Johanna Batsching, Reinhard Wolf², Martin Heisenberg³

¹Rudolf Virchow zentrum, AG Heisenberg, Kontakt Rudolf-Virchow-Zentrum/ DFG-Forschungszentrum für Experimentelle Biomedizin der Universität Würzburg Josef-Schneider-Str. 2, Haus D15, 97080 Würzburg, Germany

²Rudolf Virchow zentrum, AG Heisenberg, Kontakt Rudolf-Virchow-Zentrum/ DFG-Forschungszentrum für Experimentelle Biomedizin der Universität Würzburg Josef-Schneider-Str. 2, Haus D15, 97080 Würzburg, Germany

³Rudolf Virchow zentrum, AG Heisenberg, Kontakt Rudolf-Virchow-Zentrum/ DFG-Forschungszentrum für Experimentelle Biomedizin der Universität Würzburg Josef-Schneider-Str. 2, Haus D15, 97080 Würzburg, Germany

The Shockbox is a novel apparatus suited for studies of learning and walking activity in *Drosophila melanogaster*, based on a design first introduced by Wustmann et al. (1996). The flies are trained and tested in a closed chamber (29x2x4 mm) in which their position is continuously monitored. By applying punishment (100 Volt DC), we can perform two experiments: In one we train the flies to avoid one side of the chamber (place-learning). It consists of a 1 minute Pretest, 3 Training phases (each 1 minute) alternated by 3 Test phases (each 1 minute). As a result the flies avoid the punished side significantly. This finding corresponds to cases of aversive odor learning in a similar setup (Chlaridge-Chung et al., 2009). In a second experiment (no-idleness learning) animals are divided into two groups, 'Master' and 'Yoked'. The experiment includes a 1 minute pretest, 10 minutes training, followed by 1 minute posttest. The Master fly is punished in case it rests for >1 second. The Yoked fly in a different chamber is punished together with the Master fly, independently of what it is doing. During training and test, Yoked flies reduce their walking activity more and rest longer than Master flies. Master flies make more but shorter stops. We suggest that the behavioural difference between the two groups is a hint for pure operant learning of the flies. This is still subject of further research.

Policy learning in self-organising spiking networks through neuromodulation of synaptic transmission

Simon M. Vogt, Ulrich G. Hofmann²

¹University of Lübeck, Institute for Signal Processing, Lübeck, Germany

²University of Freiburg, Surgical Clinic, Freiburg, Germany

We present a new method for modelling the application of neuromodulators (DA) into a spiking neural network that uses spike timing dependent plasticity (STDP). Instead of forming a three-factor rule directly affecting the change of synaptic weights, we model a neuromodulatory reinforcement signal as influencing a synapse's gain during synaptic transmission. The current neuromodulator level thereby directly affects a postsynaptic neuron's firing behaviour, and only indirectly affects any subsequent change of weights, which depends on pre- and postsynaptic activity.

While each postsynaptic neuron randomly and unsupervisedly tunes to exactly one of the frequently presented polychronous input patterns at tonic (medium, baseline) DA levels, its instantaneous spike response to a given set of inputs can be strongly altered by slightly varying the neuromodulator level during transmission, leading to a stronger (high DA) or weaker (low DA) probability of tuning to a given pattern. No mutual inhibition is needed for this behaviour. The network receives constant-rate polychronous inputs, and selects learnt good state-action-pairs (trained patterns) through an increased instantaneous population response. We use this ability to construct a self-regulatory dopaminergic network simulation of biologically more plausible policy learning in the basal ganglia's striatum.

Characterization of singing and listening associated firing patterns of six different neuron types in basal ganglia song nucleus Area X during song development

Lisa Kolb, Constance Scharff², Richard Hahnloser¹

¹ ETH/UZH Zurich, Institute of Neuroinformatics, Winterthurerstr. 190, 8057 Zurich, Switzerland

² Freie Universität Berlin, Institute of Biology, Takustr. 6, 14195 Berlin, Germany

Young zebra finches learn to produce their stereotyped song by imitation of an adult tutor bird. Using auditory feedback they transform their initially highly variable juvenile subsong into a stable copy of a memorized tutor song. This goal-directed motor learning requires a specialized basal ganglia thalamocortical circuit, known as the anterior forebrain pathway (AFP), driving the necessary motor exploration for vocal learning. Area X, an essential nucleus of the AFP, is located in the dorsal striatum and contains both striatal and pallidal neuron types. Whereas several neurophysiological studies described the behavior of Area X neurons either during singing or during listening to song, none has so far addressed the integrated sensorimotor properties of Area X neurons. We characterized the firing patterns in different types of Area X neurons in awake and freely moving zebra finches using chronically implanted single high impedance electrodes. We recorded throughout the complete course of song development (~ 45 days), i.e. before, during, and after tutoring, until the song crystallized. Stable recordings were obtained from four striatal and two pallidal neuron classes, starting from early subsong until crystallized adult song. All six neuron classes were responsive during song and showed increased activity shortly before song onset. Four neuron classes, including both pallidal and two striatal classes were tonically active even when the bird was not singing, whereas two classes were only spiking during song. The latter class included medium spiny neurons that receive input from the pallial/cortical-like song nucleus HVC and which exhibited very precise syllable-locked firing patterns. Because Area X neurons respond to playback of the bird's own song (BOS) in anesthetized adults, we investigated whether we could observe a similar behavior in awake non-singing juveniles. In response to BOS playback firing rates hardly increased, but we found significant similarities in firing patterns associated with production and playback of specific song features. Our results indicate that firing of Area X neurons in juveniles is modulated by sensory stimulation. Perhaps the structure of this auditory responsiveness can provide us with a clue about the manner in which auditory feedback is used by Area X to guide vocal learning.

Deciphering the architecture of the insect mushroom body to understand its role in olfactory learning and memory

G rard Lebouille

¹Freie Universit t Berlin, Institut f r Biologie - Neurobiologie, K nigin-Luise-Str. 28/30, 14195 Berlin, Germany

The mushroom body (MB) is a higher-order structure of the insect brain involved in multi-sensory integration and in learning and memory. In appetitive olfactory conditioning the animal learns to associate a neutral odor, the conditioned stimulus, with a sucrose reward, the unconditioned stimulus. The olfactory and the reward pathways are well described in the honeybee. Olfactory sensory neurons projecting to the glomeruli of the antennal lobe and projection neurons connecting the antennal lobe with the lateral horn and the calyces, the MB entry site, are cholinergic. The US pathway in appetitive conditioning is represented by an octopaminergic neuron of the subesophageal ganglion, VUMmx1, which projects bilaterally to the antennal lobe, the lateral horn and the calyces. It is expected that the simultaneous activation of neurons of the CS and of the US, during conditioning, induces a modification of the synaptic connections between these pathways. Indeed, it was shown that the cholinergic and the octopaminergic neurotransmissions in the AL and the MB calyces are important sites for memory.

However, recent advances have shown that learning and memory formation cannot be reduced to the study of the interface between the cholinergic and the octopaminergic pathways. Studies in our research group suggest that a glutamatergic neurotransmission is present in the MB calyces ^{1,2}. The manipulation of glutamate ³ and NMDA glutamate receptor ⁴ in this region modulate memory formation. The lobes, the output sites of the MB, are probably implicated in memory processes. LTP, a neural correlate of learning and memory was induced in the PE1 neuron a particular MB output neuron ⁵. We recently showed that glutamate chloride (GluCl) channels, specific to invertebrates, are necessary for memory retrieval, probably in MB neurons ⁶. Interestingly, cholinergic neurons are also important for memory retrieval in the MB lobe ⁷. These results suggest that the cholinergic and the glutamatergic neurotransmissions are interconnected in the calyces and in the lobes of the MB.

Interestingly, the neurotransmitters of the Kenyon cells, the MB intrinsic neurons, are not firmly identified. We are actually following a strategy based on molecular techniques to identify them. We identified several genes specific for different neurotransmitters and evaluate by real-time quantitative PCR and in situ hybridisation if there are expressed in Kenyon cells. A complementary project based on extracellular recordings evaluates the effect of different neurotransmitters on MB extrinsic neurons. Our first analysis, suggest that glutamate and acetylcholine are some of the neurotransmitters expressed in Kenyon cells. In this manner, we will contribute to the understanding of the MB architecture and of its role in olfactory memory.

Reference List

1. Bicker, G., Schafer, S., Ottersen, O.P. & Storm-Mathisen, J. *J. Neurosci.* 8, 2108-2122 (1988).
2. Zannat, T., Locatelli, F., Rybak, J., Menzel, R. & Lebouille, G. *Neurosci. Lett.* 398, 274-279 (2006).
3. Locatelli, F., Bundrock, G. & Muller, U. *J. Neurosci.* 25, 11614-11618 (2005).
4. M  sig, L. et al. *J. Neurosci.* 30, 7817-7825 (2010).

5. Menzel,R. & Manz,G. J. Exp. Biol. 208, 4317-4332 (2005).
6. El Hassani,A.K. et al. Eur. J Neurosci. 36, 2409-2420 (2012).
7. Louis,T. et al. Eur. J Neurosci. (2012).

Transient action of RNA-polymerase II inhibitor on learning in honeybees

Aline Loehfelm, Katja Merschbaeche¹, Uli Mueller¹

¹Saarland University, Dept. 8.3 Biosciences Zoology/Physiology-Neurobiology, Campus, 66123 Saarbruecken, Germany

In contrast to short-term memory (STM), long-lasting forms of memory require transcription processes as revealed by the application of transcription blockers. In nearly all studies, the irreversible transcription blocker actinomycin-D has been used to prove the transcription requirement of a distinct memory phase. Due to the irreversible action of the DNA-intercalator actinomycin-D, the identification of potential multiple transcription-dependent phases triggered by associative learning is very difficult to prove. To test whether multiple transcription-dependent phases are triggered by associative learning in honeybees, we characterised the properties of alpha-amanitin, a specific and transiently acting RNA polymerase II blocker. By applying a technique that allows to investigate the de novo mRNA synthesis in vivo we show that the action of alpha-amanitin characteristically differs from that of actinomycin-D.

Pathway specific neuronal dynamics in the entorhinal-hippocampal circuit

Gerrit Schwesig, Anton Sirota¹

¹Centre for Integrative Neuroscience, Physiology of cortico-hippocampal interactions, Offried-Müller-Str. 25, 72076 Tübingen, Germany

Bidirectional interaction between entorhinal cortex (EC) and hippocampal formation (HF) is thought to be crucial for encoding, consolidation and retrieval of episode-like memories. Different EC subfields are thought to contribute functionally different inputs and receive functionally different outputs in this process. EC is subdivided into medial entorhinal cortex (MEC) strongly implicated in spatial processing and lateral entorhinal cortex (LEC) more involved in object-related processing. Interaction between brain structures has been hypothesized to be facilitated and organized by coupling in network oscillations, which are reflected in the local field potentials (LFPs).

The spatially well defined anatomical architecture of the EC-HF circuit makes it possible to separate pathway specific coupling by use of high density LFP recordings. While first steps in this direction have been made with respect to MEC-HF interactions (Mizuseki et. al 2009, Colgin et al. 2009) the in vivo coupling between LEC and HF as well as LEC and MEC has received little attention so far. Here we used simultaneous high density LFP recordings of LFPs across all anatomical layers in LEC, MEC and HF in freely moving rats to study the pathway specific coupling between these three structures. We demonstrate different distributions of gamma rhythms between MEC and LEC. Furthermore we are able to show EC-HF pathway specific gamma synchronization, which emerges in specific layers of specific entorhinal subfields, exhibits distinct frequency ranges and tends to occur at specific phases of ongoing theta oscillation. Finally we show how this coupling pattern is modulated during behavioral tasks with spatial and non-spatial components.

Glucose, AMP-dependent protein kinase and learning in honeybees

Marie-Anne Croyé, Kathy Rether¹, Uli Mueller¹

¹Saarland University, Dept. 8.3 Biosciences Zoology/Physiology-Neurobiology, Campus, 66123 Saarbruecken, Germany

As in other species, the efficiency of appetitive learning and memory formation in honeybees strongly depends on the satiation state during learning. It has been convincingly demonstrated in numerous species that a low satiation level supports the formation of appetitive memory. However, the mechanisms that link the information of the metabolic state to molecular events underlying learning and memory are hardly known. We use the appetitive associative learning in honeybees to study the role of the evolutionary conserved cellular energy sensory AMP-dependent protein kinase (AMPK) in this regard. By monitoring the active form of AMPK we provide first evidence for a connection between metabolic state and AMPK activity in very distinct parts of the honeybee brain.

Search for the up-stream regulators of histone deacetylases in honeybees

Jennifer Folz, Uli Mueller¹

¹Saarland University, Dept. 8.3 Biosciences Zoology/Physiology-Neurobiology, Campus, 66123 Saarbruecken, Germany

By changing the chromatin structure and thus the efficiency of transcription processes, histone modifications have a strong impact on the regulation of gene expression. The key players that mediate histone acetylation are histone acetylases (HATs) and the antagonistically acting histone deacetylases (HDACs). Since removing acetyl groups on histones leads to a dense chromatin structure, the activity of HDACs negatively influences neuronal plasticity and memory formation. Although associative learning leads to changes in histone acetylation that influence the process of memory formation, the signalling cascades responsible for these transient changes are not yet identified.

To address this issue we use the associative appetitive learning in honeybees that triggers transient changes in the acetylation of histones. By combining HDAC assays, antibodies against HDACs, and pharmacological treatments we aim to identify the up-stream regulators that mediate the learning-induced changes in HDAC activity.

Characterization of a functional RhoSAP/Rich2 – ProSAP2/Shank3 interaction using a novel Rich2 transgenic mouse model

Claus Matti Eckert, Jürgen Bockmann², Tobias M. Boeckers², Andreas M. Grabrucker¹

¹WG molecular Analysis of Synaptopathies, Neurology Dept., Ulm University, Ulm, Germany

²Institute for Anatomy and Cell Biology, Ulm University, Ulm, Germany

Postsynaptic terminals of glutamatergic synapses in mammalian brains consist of an electron dense protein meshwork, the PSD (post synaptic density). This structure comprises distinct proteins that can be categorized according to their functional role within PSDs (e.g. scaffolding or signaling proteins). Scaffold proteins such as ProSAP2/Shank3 establish protein interactions, which in turn, stabilize the postsynaptic structure mechanically and contribute to synaptic downstream signaling.

Recently it was shown, that selective genetic deletion of the scaffolding proteins ProSAP1/Shank2 and ProSAP2/Shank3 in mice results in alterations of glutamatergic receptor composition, most notably in hippocampal and striatal glutamatergic synapses. Additionally, alterations in synaptic transmission, as well as spine numbers and morphology have been observed. Phenotypically these mice show prominent autistic-like behaviors, which leads to the conclusion that proper regulation of these proteins is crucial for correct functioning in glutamatergic terminals of these regions.

Thus, to investigate the functional role of ProSAP2/Shank3 in more detail, we performed a proteomic screen to identify new and brain specific uncharacterized ProSAP2/Shank3 interacting proteins. As a result, Rich2/RhoSAP was found and confirmed as ProSAP2/Shank3 interaction partner using multiple assays. Rich2

contains an N-BAR and RhoGAP domain as well as a C-terminal PDZ-domain (STAV-motif) linking the protein to ProSAP2/Shank3.

To further characterize the functional role of Rich2 at synapses, we created a mouse model, lacking Rich2 gene expression. As a first step, here, we investigated if alterations in the composition of prominent PSD-proteins can be observed in Rich2 KO-mice compared to baseline levels of WT-mice. We found, that certain brain regions highly expressing Rich2 (CTX, HIP and CRB), reacted with patterned alterations of PSD-proteins to reduced Rich2 gene-dosage levels. The lack of Rich2 caused significant alterations in most of the analyzed PSD-members, affecting Shanks, AMPARs, NMDARs, as well as certain MAGUKS with the highest impact.

The most intriguing observation is reflected by the fact, that reduced Rich2-levels caused two gene-dosage dependent patterns of PSD-protein alterations. To elucidate, how these changes contribute to a yet unknown phenotype, will be the main aim for further experiments.

Poster Topic

T26: Computational Neuroscience

- T26-1A** Interplay of Intrinsic Noise and Receptive Field Sizes in Electrosensory Encoding in Weakly Electric Fish
Jan Grewe, Anna Stöckl, Henriette Walz, Jan Benda
- T26-2A** Decoding context dependent movement plans from frontoparietal reach areas
Christoph Budziszewski, Axel Lindner, Alexander Gail
- T26-3A** Self-organized criticality in networks of leaky integrate and fire neurons
Maximilian Uhlig, Anna Levina, J. Michael Herrmann, Theo Geisel
- T26-4A** Resting state functional connectivity: Large-scale neural model with time-delays and system noise
Vesna Vuksanovic, Philipp Hövel
- T26-5A** Self-supervised neuronal processing of sensory streams
Robert Gütig
- T26-6A** How do channel densities and different time constants affect the dynamic gain of a detailed model of a pyramidal neuron?
David Hofmann, Andreas Neef, Ilya Fleidervish, Michael Gutnick, Fred Wolf
- T26-7A** Balanced Synfire chain
Nikolay Chenkov, Henning Sprekeler, Richard Kempter
- T26-8A** Relations between the Mandelbrot set and the central nervous system
Thomas Kromer
- T26-9A** Regulation of Glutamate Receptor Composition
Yue-Hien Lee, Hanspeter Herzog
- T26-10A** Signal transfer in neurons with central versus externalized soma
Janina Hesse, Susanne Schreiber
- T26-11A** The Na⁺ hypothesis challenged
Federico Faraci
- T26-12A** PyTempotron - a Python based implementation of the tempotron
Matthias Ihrke, Robert Gütig

- T26-13A** A Model of Lateral Interactions in Color Vision
Olivia Haas, Christian Kellner, Thomas Wachtler
- T26-1B** A computational model of hippocampal forward sweep activity at decision points
Lorenz Goenner, Julien Vitay, Fred H. Hamker
- T26-2B** Consolidation in a Hierarchical Memory Network Leads to Power-Law Forgetting
Urs Bergmann, Henning Sprekeler, Michiel Remme, Susanne Schreiber, Richard Kempter
- T26-3B** Model-free reconstruction of neuronal connectivity from calcium imaging signals
Olav Stetter, Javier Orlandi, Demian Battaglia, Jordi Soriano, Theo Geisel
- T26-4B** Fisher information model: V1 properties limit the pattern motion sensitivity of MT
Stephanie Lehmann, Alexander Pastukhov, Jochen Braun
- T26-5B** Attention improves information processing by tuning cortical networks towards critical states
Nergis Tömen, David Rotermund, Udo Ernst
- T26-6B** Physiologically-inspired neural model for the processing of dynamic facial expressions
Martin A. Giese, Girija Ravishankar, Shervin Safavi, Dominik Endres
- T26-7B** Generation of uncorrelated noise by recurrent neural networks
Jakob Jordan, Mihai A. Petrovici, Johannes Schemmel, Karlheinz Meier, Markus Diesmann, Tom Tetzlaff
- T26-8B** Supercomputers ready for use as discovery machines for neuroscience
Susanne Kunkel, Maximilian Schmidt, Jochen M Eppler, Jun Igarashi, Gen Masumoto, Tomoki Fukai, Shin Ishii, Hans Ekkehard Plesser, Abigail Morrison, Markus Diesmann, Moritz Helias
- T26-9B** Synaptic Theta Susceptibility in Spike Timing Dependent Plasticity
Christian Albers, Klaus Richard Pawelzik
- T26-10B** Symmetry breaking in populations of neuronal feature detectors
Julia Hillmann, Robert Gütig
- T26-11B** Compact Internal Representation - A Mathematical Model of Drosophila's Prediction Capabilities in Flight Control
Bianca Zaepf, José Antonio Villacorta Villacorta, Jan-Lukas Oepen, Roland Strauss
- T26-12B** Linking physiology and morphology in two types of honeybee projection neurons.
Anneke Meyer, Martin F. Brill, Wolfgang Rössler, Martin Paul Nawrot
- T26-1C** Dependence of neuronal encoding on the site of action potential initiation
Maxim Volgushev, Evgeny Nikitin, Vladimir Ilin
- T26-2C** Detection of single sources during cognitive processing of auditory stimuli

Ralf Mueller, Max Taubert, Marco Weiergräber, Joachim Klosterkötter, Stephan Ruhrmann, Anke Brockhaus-Dumke

- T26-3C** Temperature compensated responses in conductance-based models of grasshopper auditory receptors: Ionic mechanisms and metabolic cost
Frederic Roemschied, Jan-Hendrik Schleimer, Monika Eberhard, Bernhard Ronacher, Susanne Schreiber
- T26-4C** Learning lateral inhibition with inhibitory spike-timing dependent plasticity to improve stimulus discrimination in a model of the antennal lobe
Bahadir Kasap, Michael Schmuker
- T26-5C** Receptive Field Inference from Binary Spike Decisions for Responses to Non-Gaussian Stimulus Ensembles
Arne-Freerk Meyer, Jan-Philipp Diepenbrock, Frank W. Ohl, Jörn Anemüller
- T26-6C** A dynamic model for selective visual attention predicts information routing
Daniel Harnack, Udo A Ernst, Klaus R Pawelzik
- T26-7C** Neurophysiological validation of computational methods to predict cortical excitation volumes in transcranial magnetic stimulation
Alexander Opitz, Wynn Legon, Abby Rowlands, Walter Paulus, William J. Tyler
- T26-8C** Somatic sodium channels account for 2nd phase of action potential upstroke in layer 5 pyramidal cells
Andreas Neef, Michael J Gutnick, Fred Wolf, Ilya Fleidervish
- T26-9C** Sparse and reliable cortical representations emerge naturally in networks with adapting neurons.
Martin Paul Nawrot, Farzad Farkhooi
- T26-10C** Synaptic Scaling enables Dynamically Distinct Short- and Long-Term Memory Formation
Christian Tetzlaff, Christoph Kolodziejcki, Marc Timme, Misha Tsodyks, Florentin Wörgötter
- T26-11C** Intrinsic and extrinsic sources of correlated activity in recurrent networks
Moritz Helias, Tom Tetzlaff, Markus Diesmann
- T26-12C** Reconstruction of network connectivity in the irregular firing regime
Dmytro Grytskyy, Markus Diesmann, Moritz Helias
- T26-1D** Spike Pattern Detection by Frequent Itemset Mining
Emiliano Torre, Michael Denker, Christian Borgelt, David Picado, George Gerstein, Sonja Gruen
- T26-2D** Simulation of a multi-electrode array neurochip experiment with clonazepam
Kerstin Lenk, Olaf H.-U. Schroeder, Barbara Priwitzer
- T26-3D** Neuronal variability vs. precise stimulus discrimination in an olfaction-inspired network: A neuromorphic case study

Michael Schmuker, Thomas Pfeil, Martin Paul Nawrot

- T26-4D** The Extreme Learning Machine as a model to study pattern discrimination in insect brains
Niklas Flindt, Amir Madany Mamlouk, Michael Schmuker
- T26-5D** Input-dependent decorrelation of neuronal activity in barrel cortex
Birgit Kriener, Gaute T. Einevoll
- T26-6D** Reliability of algorithms for automatized detection of neuronal activity *in vitro*
Franz Carlsen, Knut Kirmse, Ernst Günter Schukat-Talamazzini, Knut Holthoff
- T26-7D** Microscopic recruitment of network spikes in recurrent networks with synaptic short-term plasticity
Christoph Bauermeister, Gustavo Deco, Jochen Braun
- T26-8D** The connectome of the spinal cord of the rat
Oliver Schmitt, Peter Eipert, Ann-Kristin Klünker, Richard Kettlitz, Pauline Morawska, Andreas Wree
- T26-9D** Winner-take-all circuits exhibit key hallmarks of binocular rivalry
Svenja Marx, Gina Gruenhage, Daniel Walper, Ueli Rutishauser, Wolfgang Einhäuser
- T26-10D** Toward a spiking multi-area network model of macaque visual cortex
Maximilian Schmidt, Sacha van Albada, Rembrandt Bakker, Markus Diesmann
- T26-11D** Action potential shape and spike encoding properties mature in parallel in cultured hippocampal neurons
Elinor Lazarov, Michael Gutnick, Fred Wolf, Andreas Neef
- T26-12D** Application of Network Theory to real living Cultures
Christian Claus Schmeltzer
- T26-13D** Desynchronizing effect of high-frequency stimulation in a generic cortical network model
Jens Christian Claussen, Markus Schütt

Interplay of Intrinsic Noise and Receptive Field Sizes in Electrosensory Encoding in Weakly Electric Fish

Jan Grewe, Anna Stöckl², Henriette Walz¹, Jan Benda^{3,1}

¹Ludwig-Maximilians Universität München, Department Biologie II, München, Germany

²Lund University, Department of Biology, Lund, Sweden ³Eberhard Karls Universität Tübingen, Institut für Neurobiologie, Tübingen, Germany

Traditionally, noise in neuronal responses is considered detrimental to neural coding since it generally decreases a neuron's response reliability. In populations of spiking neurons, however, the right amount of noise can increase the performance of the system. For example, the information transmitted by a population of neurons about a common stimulus can be increased with the right amount of independent intrinsic noise. The noise decorrelates the responses of the individual neurons such that each neuron encodes slightly different aspects of the stimulus. For a given level of the independent noise the mutual information between stimulus and the population response increases with the number of neurons in the population, i.e. the receptive field size of the target neuron, but eventually saturates setting an upper limit for a useful population size. In addition to the effects described above we found a dependence of the maximum useful population size on the bandwidth of the stimulus. For encoding low-frequency stimuli the mutual information saturates at small population sizes and the beneficial effect of noise is small whereas at broad-band or high-frequency stimuli noise together with larger population sizes boosts the mutual information considerably.

We here study this interplay between intrinsic noise, population size, and stimulus bandwidth experimentally using the electrosensory system of the weakly electric fish *Eigenmannia virescens*. The electrosensory system consists of two subsystems, the active and the passive, which are used for electrolocation -navigation as well as communication. We compare the response properties of receptors of both subsystems, i.e. the P-units of the active, and the ampullary cells of the passive electrosensory system.

We show that P-units are much noisier than ampullary receptors with respect to their baseline interspike-interval variability as well as the heterogeneity of their baseline firing rates. Natural stimuli for P-units are both high-frequency communication signals like beats and chirps as well as low-frequency and spatially more localized electrolocation signals. Since the localization signals are so small in amplitude, noise is needed to improve the representation of these signals in the P-unit population. However, because these signals are low-frequency only small populations can make use of this effect. This fits well with their spatially localized characteristics where only small receptive field sizes make sense. Accordingly, the centro-medial segment of the ELL, the next step of information processing in the hindbrain, is used for object detection. For the high-frequency communication signals, on the other hand, lots of noise and large population and thus receptive field sizes as found in the lateral segment can be utilized to detect even minute beats from very distant fish. The ampullary system is specifically tuned to low frequency signals as arising from muscle activity of other organisms. For these stimuli noise does not notably improve the encoding nor does a large receptive field support the encoding of such signals. Our findings suggest that noise in neural systems is kept low where it is not needed or is detrimental (ampullary system) but is increased where it improves information transfer (p-units).

Decoding context dependent movement plans from frontoparietal reach areas

Christoph Budziszewski, Axel Lindner², Alexander Gail¹

¹German Primate Center GmbH, BCCN Sensorimotor Group, Kellnerweg 4, 37077 Goettingen, Germany

² Hertie Institute for Clinical Brain Research, Department of Cognitive Neurology, Hoppe-Seyley-Str. 3, 72076 Tuebingen, Germany

Actions need to be chosen according to contextual rules in order to be goal-directed. In volleyball, a player has the options to play the ball either towards a visual target (another player), or an 'imagined' target (an empty location on the field). The choice is determined by the context, i.e., whether the player wants to pass the ball to her team, or to score through by-passing the opposing team's players. How does the brain integrate the context with the potential targets to prepare a goal-directed movement?

To investigate this, we used a pattern classification approach to analyze neural activity patterns in the monkey brain which were recorded during instructed planning of context-specific reaches. Monkeys had to perform a memory guided pro- and anti-reach task. We decoded the planned reach directions based on the activity from many independent recording sites in the parietal reach region (PRR) and the dorsal premotor cortex (PMd), both known to be involved in movement planning. Based on individual neurons' tuning properties in both areas, we suspected PMd to have a better representation of the contextual rule, and PRR to have a better representation of spatial targets, at least during the early phases of space-context integration. We devised a two-step hierarchical decoding approach, in which complementary components of the decoder only received selective input from either area. This simulated downstream processing with selective input from the two areas. We computed the spike count from all independent recording channels within a selected time-window as input for the decoder. The decode performance was computed with a n-fold k-Nearest Neighbor cross-validation algorithm. We hypothesized that reach movement direction might be significantly better decoded based on information recorded in PRR if the interpretation of the information is dependent on the contextual rule decoded from PMd (hierarchical decode), rather than when it is based on the data from PRR alone (PRR decode).

Preliminary results for both context rule decode performance (chance level 50%, two rules) and movement goal decode performance (chance level 25%, four reach directions) during the stationary phase of an instructed delay, i.e. during sustained movement planning after all relevant information had been provided to the monkey, are shown in the table. In summary, PMd showed overall worse decode performance than PRR, notably with lower performance on contextual information. In contrast to our expectation, the movement direction decode is not better when information from PMd is used to decode the context and in turn to select the proper direction decoder for PRR data.

These results seemingly question the usefulness of a hierarchical two-step decoding approach for extracting context-specific reach goal information from the frontoparietal reach network. The likely explanation is that if a hierarchical information flow is really relevant for frontoparietal sensorimotor integration, then it must take place previous to our analyzed time point. To assess this, we currently perform time-resolved analyses at a higher temporal resolution, testing the hierarchical decoder performance from the time of instruction of the monkey to the onset of movement. This test will provide insight to possible dynamic changes in the frontoparietal processing hierarchy.

	Animal A		Animal S	
	Context	Movement Direction	Context	Movement Direction
PMd	63.5%	73.1%	80.1%	83.0%
PRR	71.1%	83.9%	96.9%	89.9%
Hierarchical		81.2%		81.2%
Combined		91.7%		92.7%

Both, spatial movement goals and the behavioral context were decoded from monkey areas PRR and PMd, either in a single step based on all neural data stemming from within one area, or based on data from both areas. Alternatively, we used a double-step decoder, with data for the first decoding step stemming from PMd, and data for the second decoding step stemming from PRR (hierarchical decode). Percentages show decoding performance.

Self-organized criticality in networks of leaky integrate and fire neurons

Maximilian Uhlig, Anna Levina^{1,2,4}, J. Michael Herrmann^{3,4}, Theo Geisel^{1,4}

¹Max Planck Institute for Dynamics and Self-Organization, Am Faßberg 17, 37077 Göttingen, Germany

²Max Planck Institute for Mathematics in the Sciences, Inselstraße 22, 04103 Leipzig, Germany

³University of Edinburgh, School of Informatics, IPAB, 10 Crichton Street, Edinburgh EH8 9AB, United Kingdom

⁴Bernstein Center for Computational Neuroscience, Am Faßberg 17, 37077 Göttingen, Germany

The paradigm of self-organized criticality (SOC) [1] promises many attractive features for neuronal circuits operating in the critical regime. SOC has been connected to enhanced computational abilities [2], information transmission and storage [3, 4, 6] as well as maximal sensitivity to sensory stimuli [5]. Originally studied in sandpile models [1], interest in SOC soon spread to neuroscience and many other fields. After the first experimental evidence had been found in neuronal networks in vitro [6], much effort was given to obtaining a detailed understanding of SOC and its generating mechanisms both in vitro as well as in vivo. Building upon earlier work [7], the authors of [8, 9] were the first to provide a theoretical framework that allows networks of integrate and fire neurons to operate in the critical regime without the need of external parameter tuning. In this model, short-term synaptic depression proved to be a mechanism that establishes a robust critical regime with power-law sized neuronal avalanches, exhibiting a slope of -1.5 as predicted by the theory of critical branching processes [10]. However, criticality breaks down for leaky integrate and fire neurons with membrane time constants lower than ~40ms. Inspired by recent work that reports robust SOC behavior even in the presence of leaky integration [11], we first extended model [8] with synaptic currents characterized by an instantaneous step followed by an exponential decay in time. Similar to [11] we find robust critical behavior in this case for sparse random networks and membrane time constants well below ~40 ms. Moreover, we arrive at the conclusion that equally good results are obtained in a second case, where we implement synaptic step currents together with a broad distribution of synaptic delays. In both cases the dynamics in the critical regime is qualitatively different from [8], in that clear-cut avalanches are not observed. It is rather characterized by stable, constant-rate firing and a branching ratio close to the critical value of 1. Furthermore, we find that unlike in [8], synaptic adaptation mechanisms are

not needed to drive the system into the critical regime.

In summary, we successfully equipped model [8] with more realistic synaptic current dynamics (i.e. either exponential currents or a broad synaptic delay distribution), thereby restoring robust SOC behavior in networks of leaky integrate and fire neurons.

- [1] Bak, P.; Tang, C.; Wiesenfeld, K. (1987): Self-organized criticality: An explanation of the $1/f$ noise. In *Phys. Rev. Lett.* 59 (4), pp. 381–384.
- [2] Legenstein, R.; Maass, W. (2007): Edge of chaos and prediction of computational performance for neural circuit models. In *Neural Netw.* 20 (3), pp. 323–334.
- [3] Beggs, J. M. (2008): The criticality hypothesis: how local cortical networks might optimize information processing. In *Philosophical Transactions of the Royal Society A: Mathematical, Physical and Engineering Sciences* 366 (1864), pp. 329–343.
- [4] Haldeman, C.; Beggs, J. M. (2005): Critical Branching Captures Activity in Living Neural Networks and Maximizes the Number of Metastable States. In: *Phys. Rev. Lett.* 94 (5), 058101.
- [5] Kinouchi, O.; Copelli, M. (2006): Optimal dynamical range of excitable networks at criticality. In: *Nat Phys* 2 (5), pp. 348–351.
- [6] Beggs, J. M.; Plenz, D. (2003): Neuronal avalanches in neocortical circuits. In: *J. Neurosci.* 23 (35), pp. 11167–11177.
- [7] Eurich, C.; Herrmann, J. M.; Ernst, U. (2002): Finite-size effects of avalanche dynamics. In: *Phys. Rev. E* 66 (6), 066137.
- [8] Levina, A.; Herrmann, J. M.; Geisel, T. (2007): Dynamical synapses causing self-organized criticality in neural networks. In *Nat Phys* 3 (12), pp. 857–860.
- [9] Levina, A.; Herrmann, J. M.; Geisel, T. (2009): Phase Transitions towards Criticality in a Neural System with Adaptive Interactions. In *Phys. Rev. Lett.* 102 (11), 118110.
- [10] Zapperi, S.; Lauritsen, K.; Stanley, H. (1995): Self-Organized Branching Processes: Mean-Field Theory for Avalanches. In *Phys. Rev. Lett.* 75 (22), pp. 4071–4074.
- [11] Millman, D.; Mihalas, S.; Kirkwood, A.; Niebur, E. (2010): Self-organized criticality occurs in non-conservative neuronal networks during 'up' states. In: *Nat Phys* 6 (10), pp. 801–805.

Resting state functional connectivity: Large-scale neural model with time-delays and system noise

Vesna Vuksanovic , Philipp Hövel^{1,2,3}

¹Technische Universität Berlin, Germany

²Bernstein Center for Computational Neuroscience Berlin, Germany,

³Northeastern University, Boston, US

Spatio-temporally organized low-frequency fluctuations (<0.1 Hz) of blood-oxygen-level-dependent (BOLD) fMRI signal have been intensively investigated as a measure of functional connectivity (FC) between region pairs in the whole brain [1,2]. Resting state FC is commonly assumed to be shaped by the underlying anatomical connectivity. Furthermore, it has been suggested that its strength, persistence and spatial properties are constrained by the large-scale anatomical structure of the cortex [3]. However, strong resting state FC is often observed between pair of remote cortical regions, even without apparent direct anatomical connections [4]. Mechanisms generating resting state FC are largely unknown and it has been suggested that indirect connections, interregional distance and collective effects governed by network properties of the cortex play significant role. In addition, some theoretical studies on large-scale brain networks, demonstrated importance of time delays in the networks dynamics in generation of resting state FC fluctuations [5,6]. To address these questions we investigated large-scale neural network model of the human cortex FC. Our model is based on an empirically derived resting state network consisting of 64 region of interest (ROIs) (network nodes) chosen from all over the cortex. The ROIs were adapted from a study of functional segmentation of the brain cortex using high-model-order independent component analysis [7]. There were 30 pairs of inter-hemispheric homologues and 4 additional ROIs were chosen along the midline.

Correlation matrices, characterizing FC between these regions, are used as entries for exploration of the network topologies and dynamics. The network topology measures are characterized by graph theory methods and its dynamics is modelled as system of 64 neural oscillators (described by FitzHugh-Nagumo equations), one for each particular network node, coupled by time-delayed interaction terms and with the presence of noise. Thresholded correlation matrices are used to create cortex functional networks. We investigate how network topologies change depending on the threshold. Similarly, networks dynamics simulated for different spatio-temporal networks, which are created after thresholding correlation matrices, enables us to characterize parameters important for the emergence of the coherent fluctuations in the network. We show that combination of the network topologies and different time-delays could account for the presence of the so-called functional connectivity between remote cortical regions of the human cortex.

[1] B.B. Biswal *et al.*, Magn. Res. Med. 34, 537 (1995).

[2] S. Bressler & V. Menon, Trends. Cogn. Sci. 14, 277 (2010).

[3] C.J. Honey *et al.*, Proc. Natl. Acad. Sci. 106, 2035 (2009).

[4] J.L. Vincent *et al.*, Nature 447, 83 (2007).

[5] A. Ghosh *et al.*, Cogn. Neurodyn. 2, 115 (2008).

[6] J. Cabral *et al.*, Neuroimage 57, 130 (2011).

[7] V. Kiviniemi *et al.*, Hum. Brain. Map. 30, 3865 (2009).

Self-supervised neuronal processing of sensory streams

Robert Gütig

¹Max Planck Institute of Experimental Medicine, Theoretical Neuroscience, Hermann-Rein-Str. 3, 37075 Göttingen, Germany

During behavior, a continuous stream of sensory information reaches the central nervous system in the form of a high-dimensional spatio-temporal pattern of action potentials. When processing such activity, a large class of sensory neurons responds with exquisite tuning and high specificity to temporally local stimulus features, such as phonemes within a sentence or faces within a movie. Often the temporal extent of such embedded features is several orders of magnitude shorter than the duration of the encompassing, behaviorally meaningful sensory episode. It is commonly hypothesized that the emergence of such feature detector neurons during learning requires feedback about the temporal structure of the training data or its temporal segmentation to bridge between the time scales of behavior and single neuronal responses. However, it is unclear how such temporal feedback or segmentation is implemented in neuronal systems, in particular before learning has taken place.

Here we demonstrate, that only the number of feature occurrences without any temporal information is sufficient to train model neurons to detect brief generic spatio-temporal patterns of spikes that arrive embedded in long streams of random background activity of the same statistics. To achieve this we generalize the binary tempotron[1] into a multi-class classifier. In contrast to the 'fire' or 'remain silent' classifications that can be implemented by the original model, the multi-class tempotron can be trained to generate an arbitrary number of output spikes in response to given input spike pattern. Using this learning rule we successfully train model neurons to respond to embedded spike patterns with an arbitrary number of output spikes, ranging from single spikes to bursts. Neurons can even learn simultaneously to respond to different individual features within their input streams with different numbers of spikes. Also for such multi feature regression tasks it suffices to provide the neuron with the aggregate desired output spike count during training. Neither temporal information nor the number of contributing features are required. When the embedded features have a continuous topological organization in the space of multi-neuronal spike patterns, neurons can readily learn to implement a broad range of tuning curves.

We show that the surprising simplicity of the required supervisory signaling allows neuronal networks to self-supervise: A single feedback cell that serves as a neuronal supervisor and provides each cell within a group of neurons with the mean population spike count as a label suffices to enable the neurons to learn to detect and reliably signal reoccurring spike patterns in their input activity without any external supervision. When coupling several of such self-supervised neuronal populations through lateral inhibition we observe the formation of continuous neuronal feature maps. Our results demonstrate that simple biologically plausible neuronal networks can readily master complex feature detection tasks without external temporal segmentation or supervision.

[1] Gütig R. & Sompolinsky H. (2006). The tempotron: a neuron that learns spike timing-based decisions. *Nat. Neurosci.* 3, 420-428.

How do channel densities and different time constants affect the dynamic gain of a detailed model of a pyramidal neuron?

David Hofmann, Andreas Neef^{1,2}, Ilya Fleidervish³, Michael Gutnick⁴, Fred Wolf^{1,2}

¹Max Planck Institute for Dynamics and Self-Organization, Göttingen, Germany

²Bernstein Center for Computational Neuroscience Göttingen

³Ben-Gurion University of the Negev, Israel

⁴Hebrew University of Jerusalem, Israel

The axon initial segment (AIS) controls the transformation of dendrosomatic synaptic input into spike output and the backpropagation of action potentials into the dendrites due to its lower spike initiation threshold. Channel density and kinetics can both contribute to this low threshold. However, the nature of such threshold differences is unknown and topic of current debates.

Dynamical response properties give a constraint on the AIS function. Here we study the dynamical response properties of a detailed multi compartment NEURON model that well reproduces the sodium concentration changes in the AIS and soma generated by action potential firing in a layer 5 pyramidal cell (Fleidervish et al. 2010).

To study these properties, we inject different current stimuli into the soma. These are constant currents and Gaussian noise currents as studied by (Higgs and Spain 2009).

We vary the sodium and potassium channel densities at the axon initial segment as well as the sodium activation time constant t_m . Furthermore, we study the influence of input current parameters as mean, variance and correlation time.

We then calculate the dynamic rate response of a population of independent neurons. This is described at linear order by a filter function with frequency dependent gain (Higgs and Spain 2009).

The f-I curves show that the neuron model under investigation is of type I. This holds true for all channel densities tested. The cut-off frequency appears insensitive to AIS channel density and mean firing rate, but is affected by changes of the input current time constant.

Balanced Synfire chain

Nikolay Chenkov, Henning Sprekeler^{1,2}, Richard Kempter^{1,2}

¹HU-Berlin, Institute for Theoretical Biology, Invalidenstr. 43, 10115 Berlin, Germany

²BCCN-Berlin, Philippstr. 13, Haus 6, 10115 Berlin, Germany

Electrophysiological recordings suggest that cortical circuits operate in a regime where the excitatory and inhibitory currents received by individual neurons are highly correlated in both time and stimulus selectivity [1,2]. For such balanced input, neurons are activated by fluctuations in the input and therefore tend to fire asynchronously and at irregular time intervals, a regime known as asynchronous irregular state [3].

However, during certain perceptual tasks or behavioral states, transient synchronization and precise sequential firing has been observed. The neural mechanism behind these activity patterns has not yet been resolved. Synfire chains, feed-forward networks with convergent-divergent connections between subsequent groups of neurons [4], are a candidate mechanism that explains these effects as a propagating activation of different neural populations. A prominent feature of the synfire chains is that they require a connectivity between the groups that is high compared to most physiological findings.

In this project we extend the synfire chain approach by (i) additional recurrent connections within the groups of the chain and (ii) an inhibitory plasticity rule that balances excitation and inhibition [5] in sequentially connected assemblies of neurons. This balanced variant of the classical synfire chain dramatically reduces the connection probability between subsequent groups that is required for the propagation of activity. Simulations reveal a range of parameters in which asynchronous irregular spiking coexists with reliable activation and propagation of synchronous waves.

References:

- [1] Okun & Lampl, Nat. Neurosci., 2008
- [2] Monier, Fournier & Fregnac, J. Neurosci. Methods, 2008
- [3] Vogels, Rajan & Abbott, Ann. Rev. Neuroscience, 2005
- [4] Diesmann, Gewaltig & Aertsen, Science, 1999
- [5] Vogels et al., Science, 2011

Acknowledgements:

Supported by BMBF grants no. 01GQ1001A and 01GQ1201

Relations between the Mandelbrot set and the central nervous system

Thomas Kromer

¹Muensterklinik Zwiefalten, Neuropsychiatry, Hauptstraße 9, 88529 Zwiefalten, Germany

Introduction: As shown in figure 1(right) and described earlier[1], the Mandelbrot set contains a hidden structure, which resembles in some aspects to a thalamus. If we take the points of the set as neurons and the trajectories from points to their target-regions as axons, we see, that those trajectories target from “nuclei” to regions of the ipsi- or contralateral “hemisphere”. It is easy to simulate a neural network, which will transform a Julia set into the structure of a neural network, because there is always one trajectory respectively one axon from one origin point to one target region[2]. In the Mandelbrot set, it depends on the vector c in the formula $z^2 = z_1^2 + c$, to which region an activity will be projected. A wiring structure will be proposed, which will enable a neural network, to perform the mandelbrot algorithm in its relevant aspects.

Methods and Material: The network consists of two main structures: A twodimensional layer A in which the patterns of the input are represented and their processing will be done. A second, threedimensional, structure consists of many layers B_n . Each layer will be assigned to a certain region of the twodimensional layer. Each neuron of one layer B_n will project to the correlated region of the twodimensional layer A with an addition of a constant vector c . Each neuron $_{x,y}$ of layer A will activate a column of all correlated neurons $_{x,y}$ of all layers B_n . As well, a neuron $_{x,y}$ of layer A will activate a whole layer, which is representing just the addition of the vector c , leading from the origin, midpoint of the coordinate-system to neuron $_{x,y}$ in layer A. Only neurons, being activated by both ways, will be able, to activate the subsequent neuron in layer A.

Results: A network as described above is able to perform the basic algorithm of the mandelbrot set. Starting at a neuron z , the activity will at last reach neuron $z^2 + c$ as shown in a very abstract form in figure 1(left). A pattern will be able to circulate a longer time within the network. This mechanism would enable the net to work as a working memory, with repetitive patterns showing up several times in the course of activations, because in the Mandelbrot set, activity will, dependent on the location, where the activity will spread from and the constant vector c , in stable circuits, attractors. Morphologically, the connections of layer A and layers B_n resemble in some aspects to the cerebellum with mossy and climbing fibres.

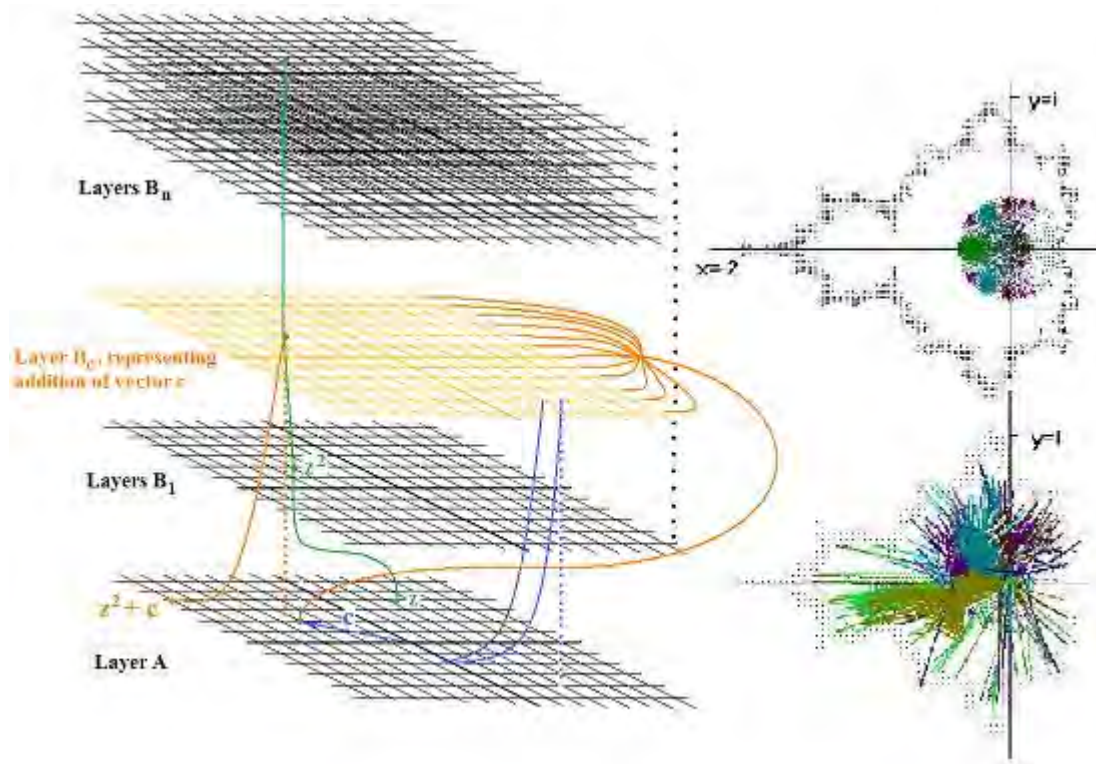

Regulation of Glutamate Receptor Composition

Yue-Hien Lee, Hanspeter Herzel¹

¹Institute for Theoretical Biology, Humboldt University, Invalidenstr. 43, 10115 Berlin, Germany

At synapses many different type of receptors participate in shaping the postsynaptic response. However, the mechanisms underlying the regulation of receptor composition is still uncertain.

At the *Drosophila* neuromuscular junction (NMJ) where up to hundreds of single synapses exist it has been shown that the glutamate receptor (GluR) composition is activity-dependent regulated (Schmid et al. 2008). Also, it is suggested that there might be a local regulation at the level of single synapses and a global regulation at the NMJ (Peled et al. 2011).

Here, we try to identify possible mechanisms in regulating GluR composition at synapses using a spatio-temporal model. We will investigate the interplay between a global and local regulation and how they effect GluR incorporation.

Signal transfer in neurons with central versus externalized soma

Janina Hesse, Susanne Schreiber^{1,2}

¹Bernstein Center for Computational Neuroscience Berlin, Philippstr. 13, Haus 6, 10115 Berlin, Germany

²Institute for Theoretical Biology, Humboldt Universitaet zu Berlin, Invalidenstr. 43, 10115 Berlin, Germany

Two neuronal morphologies, distinguished by the position of the soma, have developed in the animal kingdom. In the central nervous system of mammals, multi- or bipolar neurons are most prevalent; dendrites and axon arise directly from the soma, which is therefore in a central position. Unipolar neurons, with "externalized" soma, are most prevalent in the central nervous system of higher invertebrates. In unipolar neurons, the soma connects to the axon and dendrites only via a thin process of several tens or hundreds of micrometers called primary neurite. Whether the particular position of the soma - central or externalized with respect to dendrites and axon - fulfills a functional role and provides mammals and/or higher invertebrates with specific advantages is unknown.

Here, we explore several hypotheses how evolutionary constraints may have shaped neuronal morphology in higher invertebrates and mammals. We investigate both the bipolar and unipolar morphology based on a simplified multicompartmental model (see Fig.). In the passive model, the transfer resistance between dendrite and axon initial segment (AIS), i.e. the ratio of AIS voltage change and dendritic input current amplitude, depends on the location of the soma. We measure the transfer resistance in bipolar and unipolar model neurons for different soma diameters and different internal resistances. The space spanned by these two parameters is separated into two regions, one where the unipolar neuron has the higher transfer resistance, and one where the bipolar neuron has the higher transfer resistance. For several bi- and unipolar neurons with experimentally established internal parameters, we test where those neurons are located in the parameter space, and indeed, unipolar neurons lie in the region for which the transfer resistance of the unipolar model is higher, and bipolar neurons lie in the region for which the transfer resistance of the bipolar model is higher. Thus, the neuronal shape (bipolar or unipolar) seems to maximize transfer resistance. We interpret higher transfer resistance as advantageous for signal transmission, because the same dendritic current stimulus induces a larger voltage change in the AIS. To investigate whether the larger voltage change also facilitate spike initiation, we introduce active ion channels in the AIS of both models and record the minimal dendritic current amplitude needed for spike generation in the AIS. We find that for most biological relevant parameters the bipolar neuron needs more stimulation for spike generation compared to the unipolar neuron. Using the minimal stimulation as an estimate for the energy consumed during synaptic transmission, our results suggest that the bipolar neuron with passive soma is less energy efficient than the unipolar neuron. Active ion channels in the soma of the bipolar neuron can considerably decrease its minimal stimulation amplitude. Thus, an active bipolar soma can equalize the synaptic energy transmission for both morphologies. However, an active bipolar soma also increases the energy needed for spike initiation measured as the integrated sodium current flowing through the membrane. We conclude that in both cases the unipolar morphology is energetically advantageous for active signal transmission. Our current research hence concentrates on the question which advantages the bipolar morphology implies, with a focus on noise robustness and signal control.

Acknowledgements:

This work was funded by grants from the Federal Ministry of Education and Research, Germany (01GQ1001A, 01GQ0901) and the Deutsche Forschungsgemeinschaft (SFB618, GK1589/1).

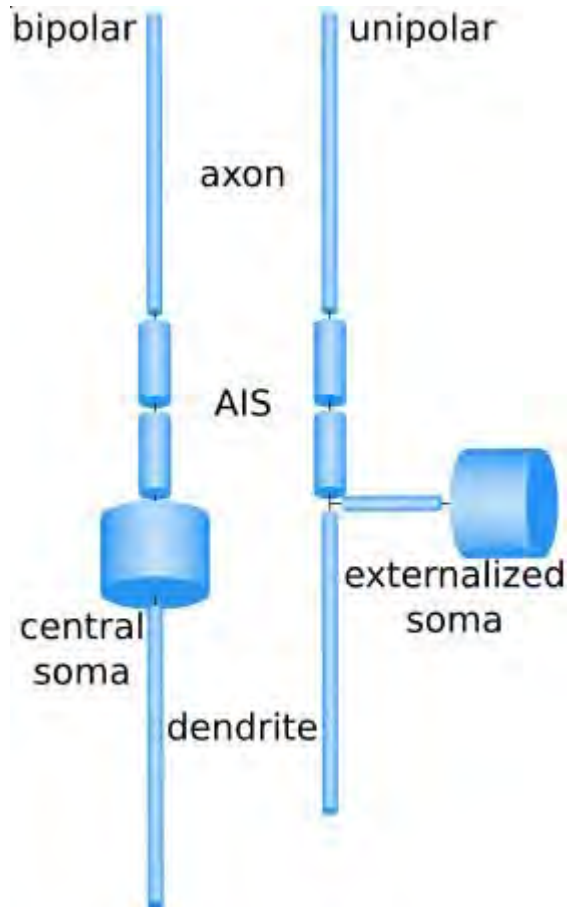

The Na⁺ hypothesis challenged

Federico Faraci

¹Max Planck Institute for Dynamics and Self Organization, Nonlinear Dynamics, Bunsenstrasse 10, 37073 Goettingen, Germany

The Na⁺ hypothesis states that action potentials are generated by a transmembrane flow of Na⁺ ions occurring as a consequence of permeability changes in the excited cell. According to this view, depolarization would follow from Na⁺ ions moving from the extracellular space to the intracellular one under the influence of their concentration gradient.

In this work I evidence some challenges for the validity of the Na⁺ hypothesis. To do so, I start from the analysis of the paper from which the idea originated, i.e. "The effects of sodium ions on the electrical activity of the giant axon of the squid" by Hodgkin and Katz. Of this paper, I evidence the limitations focusing in particular on the logical errors underlying the planning and interpretation of the experiments there presented in support of the hypothesis. Specifically, I argue that substitution of the extracellular sodium with choline does not allow to conclude anything about the necessity of the former cation in the process of nerve excitation.

I continue by citing part of the several experimental observations that appeared in the literature so far contradicting the Na⁺ hypothesis. It will be shown that the Na⁺ hypothesis has been found not to hold in Nitella, marine crustaceans, frogs, mammals. Even the squid giant axon will be seen not to satisfy the assumptions made by Hodgkin, Katz, and Huxley, depolarization having been obtained here in the presence of an inverted transmembrane Na⁺ gradient (i.e. [Na⁺]_{out} < [Na⁺]_{in}) as well as in the absence of extracellular Na⁺ (in fact also in the absence of any monovalent cation in the bathing medium). In light of the logical errors underlying the derivation of the Na⁺ hypothesis, the observations mentioned will appear not at all surprising.

I conclude contextualizing the work by making reference to the way the Na⁺ hypothesis is taught in the most popular neuroscience textbooks, "Principles of Neural Sciences" by Kandel et al. and "Neurosciences" by Purves et al. in particular. The risks of teaching concepts of which we still don't have a clear understanding (such as for example nerve excitation) in a simplistic and uncritical manner will be evidenced and shortly discussed.

PyTempotron - a Python based implementation of the tempotron

Matthias Ihrke, Robert Gütig¹

¹Max Planck Institute of Experimental Medicine, Theoretical Neuroscience, Hermann-Rein-Str. 3 , 37075 Goettingen, Germany

Recent electrophysiological data have emphasized the importance of action potential timing in neuronal representations of sensory stimuli. Experiments in visual, auditory, olfactory, and somatosensory pathways have shown that the spikes elicited in response to a stimulus can be precisely timed relative to a stimulus event or relative to other action potentials of the same or of other neurons. However, it has remained controversial to what extent neuronal circuits are able to decode such spike-timing based representations and utilize them for sensory computations and processing. To address these questions, a biologically plausible neuron model, the tempotron[1], has recently been proposed. Using this model, it has been shown that simple neuronal architectures have a high capacity to decode a broad range of spike-timing based neuronal codes. Moreover, applications of the tempotron to visual[2] and olfactory spike recordings have demonstrated its viability to real sensory spike patterns.

Although a growing number of empirical studies have included abstract decoding schemes when analyzing multi-neuronal sensory spike patterns[3,4], the use of the more biological tempotron has remained challenging due to its elevated level of computational sophistication. To facilitate the tempotron's applicability to real data sets and further studies by a broader community, we present here a fast open source implementation with a high-level language interface.

To combine computational efficiency with ease-of-use, we developed a Python-package that implements the tempotron model[1] and interfaces to highly optimized numerical routines to boost its runtime performance. This architecture enables the user to profit from Python's powerful interactive scripting engine and its workspace functionality while retaining the performance level of compiled code. In addition, we provide functionality for using the package for parallel computing on high-performance-clusters using the Message Passing Interface (MPI). The software implements an object-oriented design which provides a common interface to different types of neuron-models and which ensures flexible maintenance and extensibility (see Figure). A unit-test suite and API documentation is provided.

We present example scripts to apply the tempotron to different coding problems as well as to real data. The package that is released under an open-source license can be downloaded from <http://www.tempotron.org> where we also provide extensive documentation and examples.

[1] Gütig, R., & Sompolinsky, H. (2006). The tempotron: a neuron that learns spike timing-based decisions. *Nature neuroscience*, 9(3), 420-428.

[2] Gütig, R., Gollisch, T., Meister, M., & Sompolinsky, H. (2007). Tempotron Decoding of Spike Patterns from Retinal Ganglion Cell Populations. *Cosyne Abstracts*, Salt Lake City USA.

[3] Junek, S., Kludt, E., Wolf, F., & Schild, D. (2010). Olfactory coding with patterns of response latencies. *Neuron*, 67(5), 872-884.

[4] Cury, K. M., & Uchida, N. (2010). Robust odor coding via inhalation-coupled transient activity in the mammalian olfactory bulb. *Neuron*, 68(3), 570-585.

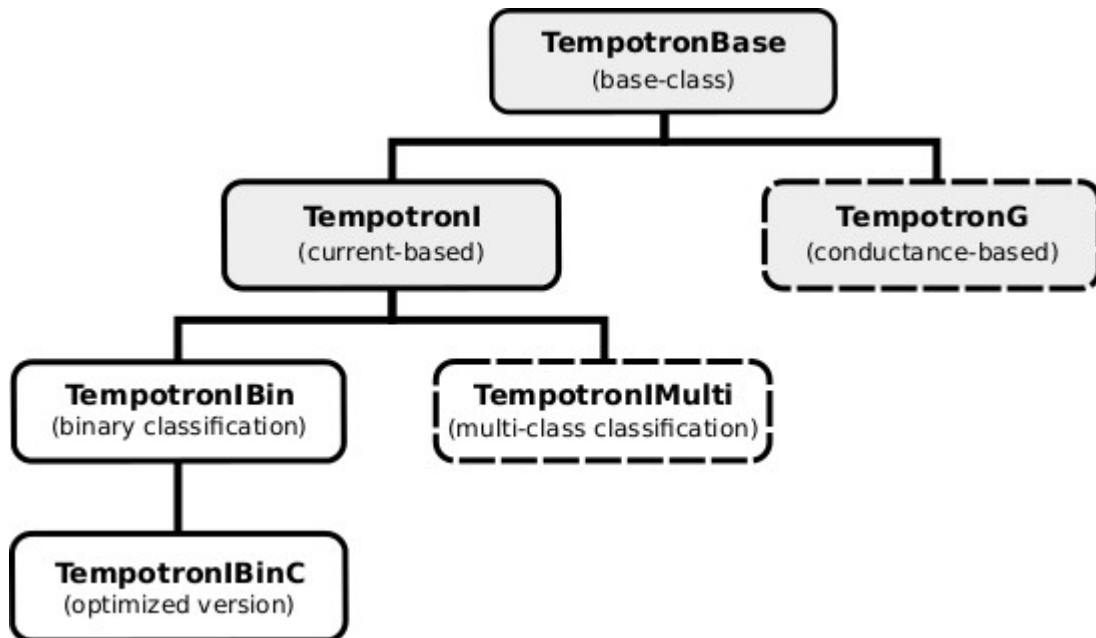

A Model of Lateral Interactions in Color Vision

Olivia Haas, Christian Kellner^{1,2}, Thomas Wachtler^{1,2,3}

¹Department Biologie II, Ludwig-Maximilians-Universität München, Germany

²Graduate School of Systemic Neurosciences, Ludwig-Maximilians-Universität München, Germany

³Bernstein Center for Computational Neuroscience, Germany

The perceived color of an object depends not only on the spectral composition of the light reflected from its surface, but also on the visual context such as illumination and background color. Psychophysical studies using asymmetric matching have shown systematic hue shifts in the perceived color of a given stimulus induced by background color. Such interactions are thought to underlie perceptual phenomena like color contrast and color constancy. A possible neuronal basis may be lateral interactions which manifest in contextual influence on the tuning of color-selective neurons in the visual cortex (Wachtler et al., 2003). We present a model of cortical color processing that predicts the color shifts observed in psychophysical studies. The model assumes that stimulus hue is encoded by a population of neurons with Gaussian tuning curves and preferences distributed in color space, corresponding to the finding of distributed color preferences in primary visual cortex (Lennie et al., 1990). Furthermore, the model assumes lateral inhibitory interactions between neurons sharing the same color preferences, modelled by a Difference-of-Gaussian interaction kernel. No interactions between color channels are assumed. We tested the model with inputs corresponding to stimuli of different hues presented on neutral or colored backgrounds, and determined the encoded hue from the population responses. Around the borders between stimulus and background, the modulation of neural activities due to the lateral interactions led to systematic shifts in encoded hue that were directed away from the color of the background. When the distribution of color preferences was assumed to be non-uniform in color space, the induced color shifts depended on the color of the background in a way that was similar to the dependence of perceptual color shifts on the color of the background as measured in psychophysical experiments. The results indicate that important computations in color vision can be realized using simple neural mechanisms when color is represented by a distributed code.

Supported by the Graduate School of Systemic Neurosciences and the Bernstein Center for Computational Neuroscience Munich.

References:

Wachtler, T., Sejnowski, T.J., and Albright, T.D. (2003). Representation of color stimuli in awake macaque primary visual cortex. *Neuron*, 37, 681-691.

Lennie, P., Krauskopf, J., and Sclar, G. (1990). Chromatic mechanisms in striate cortex of macaque. *Journal of Neuroscience*, 10, 649-669.

A computational model of hippocampal forward sweep activity at decision points

Lorenz Goenner, Julien Vitay¹, Fred H. Hamker^{1,2}

¹Department of Computer Science, Chemnitz University of Technology, Straße der Nationen 62, 09107 Chemnitz, Germany

²Bernstein Center for Computational Neuroscience, Humboldt-Universität zu Berlin, Philippstr. 13, Haus 6, 10115 Berlin

Experimental observations of hippocampal forward sweep activity have been associated with vicarious trial-and-error (VTE) behavior at decision points in a multiple T-maze task, with extra-field activity of place cells presumably representing possible future pathways [1]. We propose a computational model of the hippocampal CA3 subfield which accounts for the sequential activation of place cells during VTE behavior. Neural activity of a hypothetical rat at the choice point of a single T-maze is simulated, showing sequential forward sweeps corresponding to both arms of the T-maze. Our functional interpretation is that hippocampal forward replay represents possible future goal states associated with the current location. The consecutive, rather than parallel, nature of the forward sweeps can be interpreted as the disambiguation of learned overlapping behavioral sequences.

The model consists of CA3 place cells with full recurrent connectivity and a small population of inhibitory interneurons, implemented using aEIF neurons with adaptive spike threshold [2], variable synaptic delays and a phenomenological model of theta phase precession [3]. The development of replay activity depends on two factors: First, running in the T-maze produces a unidirectional increase in the strength of synapses between cells with place fields visited in succession, as a result of spike-timing dependent plasticity (STDP) and phase precession. Second, synaptic transmission is assumed to be up-regulated by a neuromodulator such as ACh during the hypothesized recall phase.

Model place fields follow a fixed spatial layout showing overlap between neighboring place fields. We extend the phenomenological model of phase precession proposed for a linear track in [3] to account for phase precession as it would be expected to occur in a T-maze. Consistent with observations in open-field mazes, we assume that phase precession correlates with distance traveled through the field and occurs independent of the direction in which place fields are traversed.

An interesting property of the observed forward sweeps concerns the time scale of replay, which corresponds to the theta and gamma range [1]. We also illustrate the influence of reduced connectivity on the speed of replay.

1. Johnson, A., and Redish, A.D. (2007), Neural Ensembles in CA3 Transiently Encode Paths Forward of the Animal at a Decision Point. *J Neurosci* 27(45):12176-12189.
2. Itskov, V., Curto, C., Pastalkova, E., and Buzsáki, G. (2011), Cell Assembly Sequences Arising from Spike Threshold Adaptation Keep Track of Time in the Hippocampus. *J Neurosci* 31(8):2828-2834 .
3. Bush, D., Philippides, A., Husbands, P., and O'Shea, M. (2010), Dual Coding with STDP in a Spiking Recurrent Neural Network Model of the Hippocampus. *PLoS Comp Biol* 6 (7): e1000839

Consolidation in a Hierarchical Memory Network Leads to Power-Law Forgetting

Urs Bergmann, Henning Sprekeler¹, Michiel Remme¹, Susanne Schreiber¹, Richard Kempter¹

¹Humboldt-Universität zu Berlin, Institute for Theoretical Biology, Invalidenstr. 43, 10405 Berlin, Germany, and BCCN Berlin

Both the acquisition and the maintenance of declarative memories initially depend on the hippocampus. After a period of weeks to years, however, these memories become hippocampus-independent through a process known as system memory consolidation. This transfer of information is thought to be important for the long-term maintenance of memories [1], but the cellular mechanisms by which it is achieved are unclear. Inspired by hippocampal and neocortical anatomy, we propose a hierarchical spiking network model that consolidates memories from highly plastic to more rigid synaptic populations, thereby allowing long memory retention times.

In our model, memories are initially stored in CA3 during the day and then consolidated to shortcut connections (red pathways in the Figure) during a following sleep phase. The consolidation relies on two ingredients, which can be illustrated using the example of the network composed of entorhinal cortex, DG/CA3 and CA1. First, the information coming from entorhinal cortex through CA3 reaches CA1 with a delay compared to the information arriving through the direct perforant path (PP) connection. Second, the resulting temporal input correlations together with spike-timing-dependent plasticity (STDP) [2] in the PP copy the synaptic weight pattern from the indirect pathway through CA3 to the direct PP connection. We posit that this copying mechanism is the biological basis of system memory consolidation and show its effectiveness by mathematical analysis and simulations with conductance-based integrate-and-fire neurons.

Investigation of alternating wake and sleep phases reveals an exponential decay of the memories in the PP connection to CA1. The time constant of the decay is determined by the amount of memory copied from the indirect pathway to the PP in one sleep phase, which depends on the learning rate, the firing rates and the time spent in the consolidation phase. Less memory consolidation to the PP therefore allows longer memory retention times, but comes at the price of worse initial memory storage.

Investigations of human forgetting show a power-law decay of memories [3] rather than exponential forgetting. To reproduce this behavior, we considered a hierarchical network in which the direct connection (PP) is part of the indirect pathway of the next level (see Figure). The suggested network architecture is in line with both hippocampal and cortical anatomy. Theoretical analysis and simulations of the hierarchical system show (approximated) power-law forgetting. Furthermore, older memories yield faster responses because they are stored in increasingly shorter synaptic pathways.

In conclusion, the proposed hierarchical consolidation circuit provides a possible cellular mechanism for system memory consolidation, for the dynamics of the hippocampal involvement in declarative memory, and for the observation of power-law forgetting.

Acknowledgements.

Supported by BMBF grants no. 01GQ0901, 01GQ0972, 01GQ1201, 01GQ1001A, DFG grant no. SFB 618 and the Einstein Stiftung Berlin.

References

- [1] Diekelmann, S. and Born, J. The memory function of sleep. *Nat. Rev. Neurosci.*, 11(2):114-126, Feb 2010.
- [2] Kempter, R. and Gerstner, W. and Van Hemmen, J.L. Hebbian learning and spiking neurons. *Phys. Rev. E.*, 59(4):4498, Sep 2000.
- [3] Wixted, J.T. and Ebbesen, E.B. On the form of forgetting. *Psychol. Sci.*, 2(6):409–415, Nov 1991.

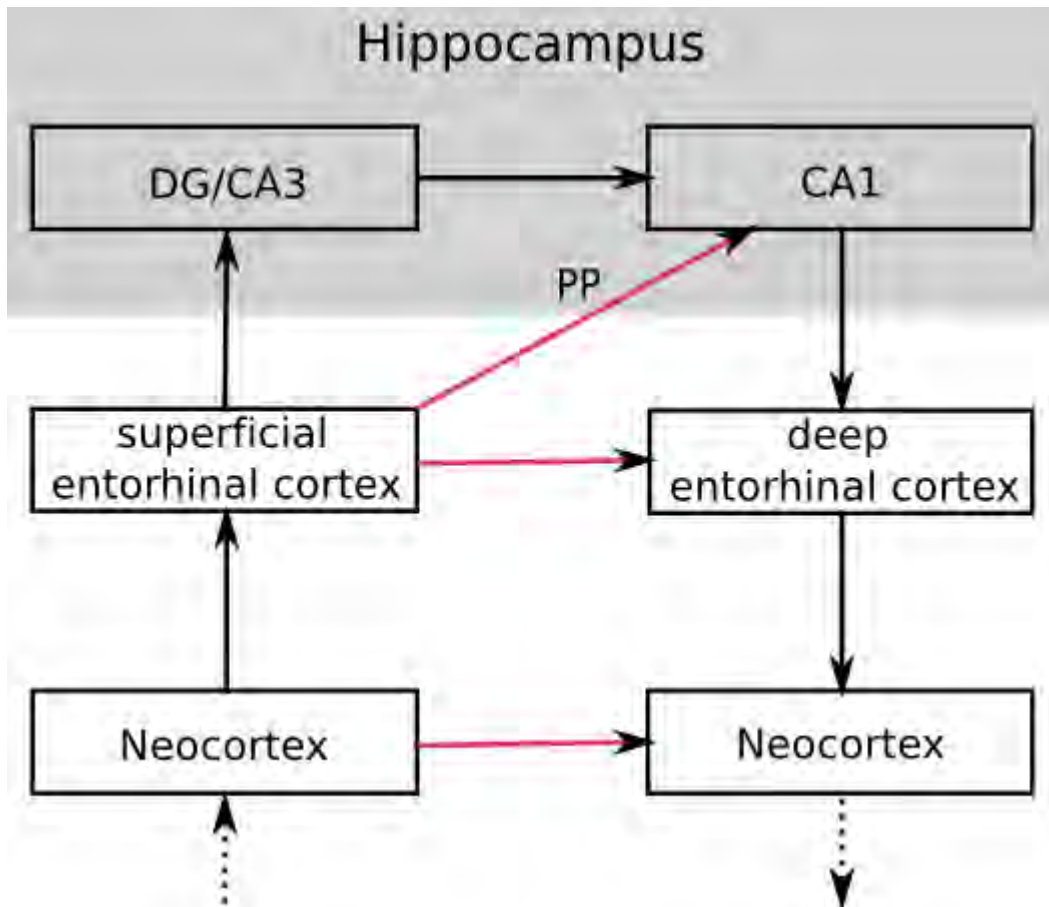

Model-free reconstruction of neuronal connectivity from calcium imaging signals

Olav Stetter, Javier Orlandi³, Demian Battaglia^{1,2}, Jordi Soriano³, Theo Geisel^{1,2}

¹Max Planck Institute for Dynamics and Self-Organization, Nonlinear Dynamics, Göttingen, Germany

²Bernstein Center for Computational Neuroscience Göttingen, Göttingen, Germany

³ECM department, Faculty of Physics, Universitat de Barcelona, Spain

Calcium imaging has become a standard technique for measuring the activity of a population of cultured neurons. Typically these recordings are slow compared to the cell dynamics and display a low signal-to-noise ratio, but they allow for the simultaneous recording of hundreds or thousands of neurons. Such neuronal cultures display spontaneous activity and switching behavior between short periods of highly synchronous, bursting activity and longer periods of relative silence.

In our work we aim to reconstruct an approximation of the excitatory structural connectivity of a culture of neurons. In order to benchmark our methods, we first study simulations of fluorescence signals and examine established methods of inferring the topology. It turns out that we can improve on these methods if we turn to measures from information theory, which do not assume linearity of the neuronal firing dynamics.

Because we are interested in directed networks, we use Transfer Entropy as the natural causal measure. It turns out that we can achieve a good quality of the reconstruction if we allow for novel extensions of this measure. Specifically, we take into account the ability of the network to display different dynamical states, where we need to focus on phases of activity where the dynamics are dominated by direct monosynaptic interactions, and we need to correct for the slow acquisition rate of the recording. We therefore introduce a new measure, called Generalized Transfer Entropy (GTE).

In our simulation, we find that even if we include a term for light-scattering between neurons (leading to an instantaneous pseudo-interaction common to real recordings) GTE is able to give a good approximation to the ground truth topology. This result holds for all networks that we studied, including networks generated to display a certain clustering coefficient or networks whose probability of connection has a certain length scale. Importantly, in both types of networks we find an approximately linear correlation between the actual and reconstructed topological indices. We also show that GTE can be used to reconstruct inhibitory connections.

Our measure is then applied to real data from large cultures of hippocampal neurons in vitro. The results show that we can extract relevant information about the structure of the network, in particular elevated levels of clustering and a broadened degree distribution. Finally, we show that a linear-based reconstruction approach (such as cross-correlation) would spuriously result in a much higher clustering, a symptom also seen in the simulations.

Fisher information model: V1 properties limit the pattern motion sensitivity of MT

Stephanie Lehmann, Alexander Pastukhov¹, Jochen Braun¹

¹Otto-von-Guericke University Magdeburg, Institute of Biology, Dept. of Cognitive Biology, Leipziger Strasse 44 / Haus 91, 39120 Magdeburg, Germany

We study the perceptual representation and model the neural representation of pattern motion. Lacking quantitative characterizations of neuronal responsiveness in area MT, we derive theoretical predictions from the responsiveness of motion-selective neurons in area V1, which are comparatively well characterized. Given a quantitative model of responsiveness (tuning and variability) to component motion, we have previously predicted the responsiveness (tuning and variability) to pattern motion, assuming statistically efficient integration of Fisher information. These theoretical results predict that sensitivity to the speed and direction of pattern motion should vary with the constitutive component motions. We now report psychophysical threshold measurements that quantitatively confirm these predictions. Five observers viewed composite arrays of two types of component Gabor-motion wavelets, reporting either the direction or the speed of pattern motion (2AFC). To reveal the differential contribution of different motion components, we varied the angle between component wavelets. Thresholds for direction of pattern motion decrease, whereas thresholds for speed of pattern motion increase, with the angle between component wavelets. In conclusion, we can predict neural responsiveness at the level of pattern motion (presumably in area MT) from psychophysical measurements and from neural responsiveness at the level of component motion (area V1). This prediction makes no assumptions about neural circuits but simply assumes statistically efficient integration of Fisher information.

Attention improves information processing by tuning cortical networks towards critical states

Nergis Tömen, David Rotermund¹, Udo Ernst¹

¹ Institute for Theoretical Physics, Department of Physics, University of Bremen, 28334 Bremen, Germany

Self-organized criticality (SOC) has been a prominent research subject since it has been linked to power-law behaviour in dynamical systems [1]. In neural systems, modeling studies have predicted power laws for avalanches of spike events [2], which were later confirmed by experimental studies on rat cortical slices [3]. However, the exact physiological mechanisms which drive neural systems towards critical states [4], or their functional relevance for information processing in the brain, are currently not known.

In a different line of research, it was experimentally shown that increased levels of visual attention correlate with an increase in the spectral power of gamma-oscillations in local field potentials (LFPs) from visual area V4 [5]. This increase in gamma-band synchronization has been linked to an improved object representation [6]. Here we investigate the neural mechanisms by which synchronization enhances visual information processing and relate the emerging network dynamics to criticality and power-law behaviour:

In order to reproduce attentional modulation of gamma-oscillations, we have simulated a recurrent network model of V4, receiving stochastic input from area V1. The V4 layer consists of randomly connected integrate-and-fire neurons, which are either purely excitatory, or constitute a network with both excitatory and inhibitory interactions. The effects of attention are represented by varying the global coupling strength within this layer. We then quantified the discriminability of the LFPs generated by such a network when presented with different visual stimuli, under different attentional conditions. In parallel, we computed the spike avalanche statistics in the V4 network, and investigated at which coupling strengths the system was closest to critical, power-law behaviour.

In the purely excitatory network, we show that there is a regime of the system, determined by the coupling strength, for which the LFP output contains maximal discriminative information about the presented stimuli. More importantly, the parameter regime where stimulus discriminability is maximal coincides with the one where the avalanche dynamics of the network comes closest to criticality. These results transfer to a mixed excitatory-inhibitory network, whose optimum working range appears to be very close to the balanced state.

In summary, our simulations predict that attention serves to shift the dynamics of the network towards a critical point, thus optimizing discriminability of neural representations.

1. Bak P, Tang C, Wiesenfeld K (1987) *Phys. Rev. Lett.* 59:381.
2. Eurich CW, Herrmann M, Ernst UA (2002) *Phys. Rev. E* 66:066137.
3. Beggs J, Plenz D (2003) *J. Neurosci.* 23:11167–11177.

4. Levina A, Herrmann JM, Geisel T (2005) *Adv. Neural Inf. Proc. Syst.* 18:771–778.
5. Taylor K, Mandon S, Freiwald WA, Kreiter AK (2005) *Cereb. Cortex* 15:1424–1437.
6. Rotermund D, Ernst UA, Taylor K, Pawelzik KR, Kreiter AK (2009) *J. Neurosci.* 29:10120–10130.

Physiologically-inspired neural model for the processing of dynamic facial expressions

Martin A. Giese, Girija Ravishankar¹, Shervin Safavi¹, Dominik Endres¹

¹CIN, HIH, BCCN, University Clinic of Tübingen, Section Computational Sensomotorics, Dept. Cogn. Neurology, Otfried-Müller Str. 25, 72076 Tübingen, Germany

Facial expressions are essentially dynamic. However, most existing research has focused on static pictures of faces. The computational neural functions that underlie the processing of dynamic faces are largely unknown. Combining multiple physiologically relevant neural encoding principles, we propose a neural model that accomplishes the recognition of facial expressions robustly over different facial identities.

Our model is based on a physiologically plausible hierarchical model of the ventral stream for the extraction of form features, building on a previous model for the processing of identity from static pictures of faces [Giese & Leopold, 2005, Neurocomputing]. It combines norm-referenced as well as example based coding of patterns, and different physiologically-inspired mechanisms for the encoding of temporal sequences.

In example-based coding, 'snapshot neurons' that are selective for frames (snapshots) from the dynamic face sequence, they are modeled by radial basis function units (see figure). These neurons are laterally coupled, resulting in a network which is a dynamic neural field with an asymmetric interaction kernel. This makes the snapshot neurons sequence selective: we find only a weak response if frames occur in an incorrect temporal order. Facial expression neurons at highest level sum activity over the neural field that encodes one facial expression (e.g. 'happy' or 'sad').

In norm-referenced encoding, face-selective neurons encode distance and direction of the stimulus relative to a norm stimulus, here neutral expressions. This computational function can be implemented by a simple feed-forward neural network [Giese & Leopold, 2005, Neurocomputing]. For static face processing this norm-referenced mechanism accounts better for the neurophysiological data than an example-based mechanism. In the dynamic case, the evolution of facial expression corresponds to a vector with increasing length in the direction of the extreme expression; face neurons show monotonic increases (or decreases) of activity during the time-course of the expression. Their output is fed into 'differentiator neurons' which are detecting raising flanks in their input, thus becoming selective to dynamic facial expressions in the correct temporal order, while they fail to respond to static expressions and ones with inverse temporal order. This proposed mechanism is more efficient in terms of neural hardware, since it encodes only neutral faces and the extreme expressions.

The model is tested with movies showing real monkey expressions ('threat' and 'coo-call') and a standard data basis containing a large number of human expressions of different individuals.

The performance of different physiologically plausible circuits for the recognition of dynamic facial expressions is evaluated, and specific predictions for the behavior of different classes of dynamic face-selective neurons are discussed, which might e.g. be suitable to distinguish different computational mechanisms based on single-cell recordings from dynamic face-selective neurons.

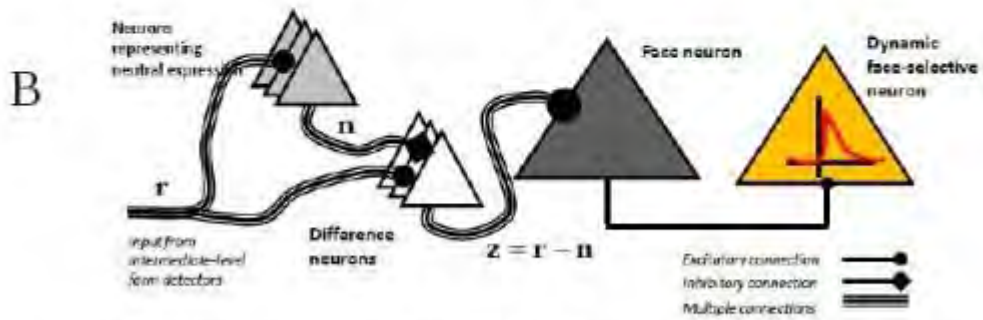
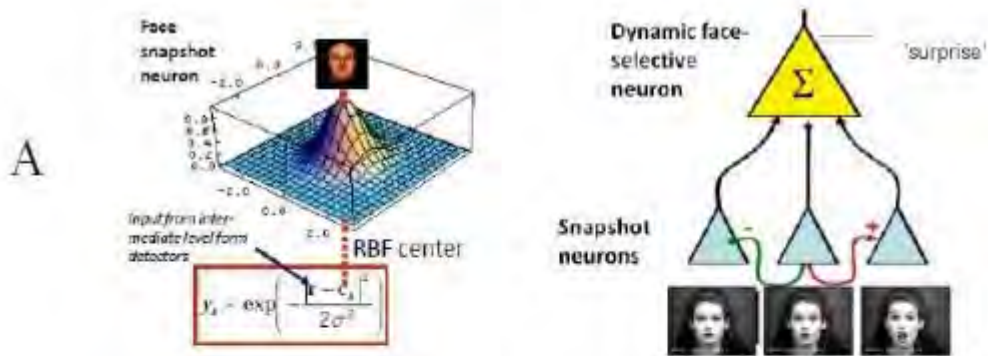

Mechanisms for encoding of dynamic facial expressions.
 A: example-based, B: norm-reference encoding

Generation of uncorrelated noise by recurrent neural networks

Jakob Jordan, Mihai A. Petrovici², Johannes Schemmel², Karlheinz Meier², Markus Diesmann¹, Tom Tetzlaff¹

¹Inst. of Neuroscience and Medicine (INM-6), Jülich Research Center, Germany

²Kirchhoff Institute for Physics, Ruprecht-Karls-University Heidelberg, Heidelberg, Germany

Models of brain functions such as perception, memory, attention or decision making often rely on the presence of noise [1]. In attractor networks, for example, synaptic-input noise enables the system to jump across barriers in the energy landscape, thereby preventing deadlocks during decision making (see figure) [1,2]. While the functional benefits of noise are well established in a variety of contexts, the origin of this noise in vivo remains unclear. Here, we investigate whether deterministic recurrent neural networks can serve as a noise source for functional network models and thereby replace artificial noise generators in numerical simulations and neuromorphic hardware [3] by a more natural mechanism. In particular, we study how noise correlations arising from the recurrent-network dynamics and the connectivity affect functional properties of attractor networks. Previous studies have shown that recurrent neural networks can generate irregular asynchronous activity by a variety of mechanisms: correlation suppression by the nonlinear spike-generation dynamics [4], synaptic failure [5], chaotic network dynamics [6], and feedback-induced decorrelation [7,8]. Neurons receiving "noise" input from a recurrent network typically share presynaptic sources. In consequence, asynchronous firing in the presynaptic population does not guarantee vanishing noise correlations in the postsynaptic targets. Recently, it has been shown that the spike-train correlation structure in recurrent neural networks arranges such that the shared-input contribution to the input correlation is nearly canceled [7,8]. Here, we demonstrate that this effect can be exploited to generate uncorrelated noise for functional network models. To illustrate the distinct role of shared-input and spike-train correlations, we compare the network performance for three scenarios where synaptic-input noise is generated by 1) independent realizations of a Poisson point process, 2) superpositions of spike trains randomly drawn from a finite ensemble of uncorrelated Poisson point processes, and 3) superpositions of spike trains randomly drawn from the finite ensemble of spike trains generated by a recurrent neural network. Noise generation by recurrent neural networks in neuromorphic hardware is tested in a software simulation of the BrainScaleS neuromorphic hardware [9].

Acknowledgments:

Supported by the Helmholtz Alliance on Systems Biology, the Helmholtz Association in the Portfolio theme "Supercomputing and Modeling for the Human Brain", the Jülich Aachen Research Alliance (JARA), the Next-Generation Supercomputer Project of MEXT, and EU Grant 269921 (BrainScaleS).

References:

1. Rolls & Deco (2010), The noisy brain: Stochastic Dynamics as a Principle of Brain Function, Oxford University Press
2. Lundqvist et al. (2006), Network: Computation in Neural Systems 17(3):253-276
3. Schemmel et al. (2010), Proceedings of the 2010 IEEE International Symposium on Circuits and

Systems

4. De la Rocha et al. (2007), *Nature* 448:802–807
5. Rosenbaum & Josic (2011), *Neural Comput* 23: 1261–1305
6. van Vreeswijk & Sompolinsky (1996), *Science* 274:1724-1726
7. Renart et al. (2010), *Science* 327:587–590
8. Tetzlaff et al. (2012), *PLoS Comp Biol* 8(8):e1002596
9. Brüderle et al. (2011), *Biological Cybernetics* 104:263-296

Figure: Speed-up of pattern switching by background noise. Distributions of attractor dwell times (log scaled) in an attractor network model [2] with (blue) and without background noise (red).

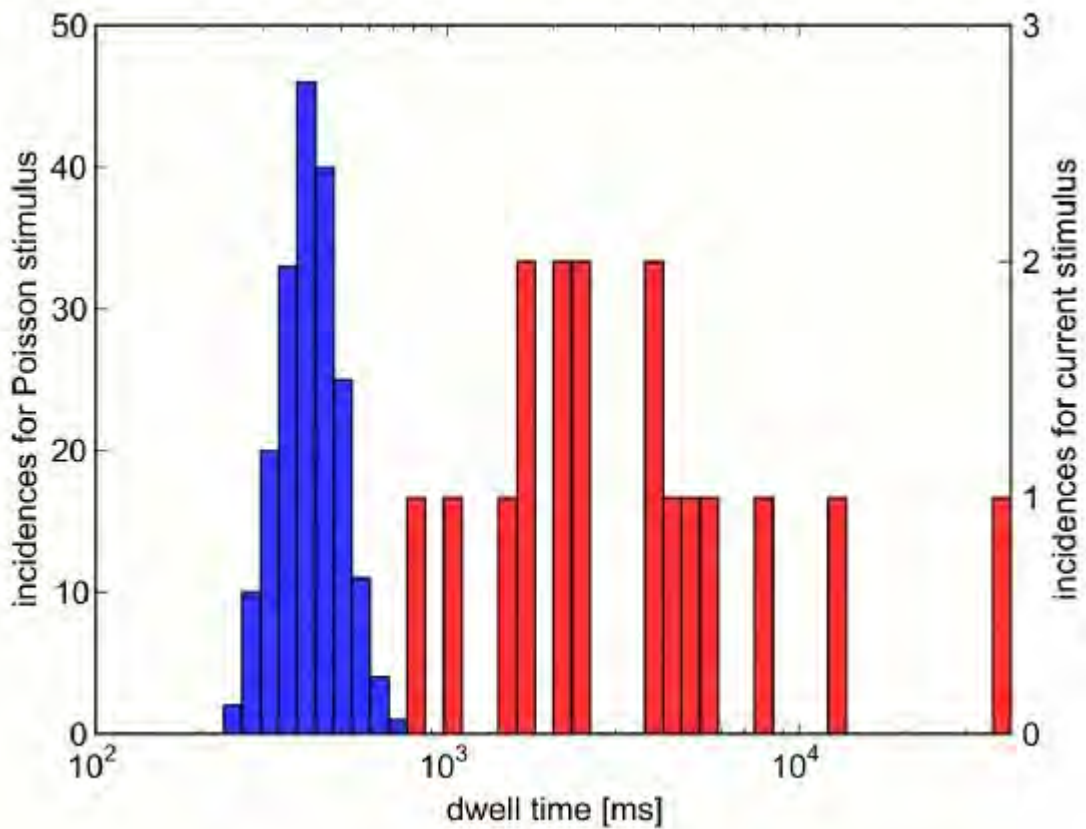

Supercomputers ready for use as discovery machines for neuroscience

Susanne Kunkel, Maximilian Schmidt¹, Jochen M Eppler¹, Jun Igarashi⁴, Gen Masumoto⁵, Tomoki Fukai⁴, Shin Ishii⁶, Hans Ekkehard Plesser⁷, Abigail Morrison^{1,2,3,8}, Markus Diesmann^{1,3,9,10}, Moritz Helias^{1,9}

¹Institute of Neuroscience and Medicine (INM-6), Computational and Systems Neuroscience, Jülich Research Centre, Germany

²Simulation Laboratory Neuroscience - Bernstein Facility for Simulation and Database Technology, Institute for Advanced Simulation, Jülich Aachen Research Alliance, Jülich Research Centre, Germany

³Bernstein Center Freiburg, Albert-Ludwig University of Freiburg, Germany

⁴Laboratory for Neural Circuit Theory, RIKEN Brain Science Institute, Wako, Japan

⁵High-Performance Computing Team, RIKEN Computational Science Research Program, Kobe, Japan

⁶Integrated Systems Biology Laboratory, Department of Systems Science, Graduate School of Informatics, Kyoto University, Japan

⁷Department of Mathematical Sciences and Technology, Norwegian University of Life Sciences, Aas, Norway

⁸Institute of Cognitive Neuroscience, Faculty of Psychology, Ruhr-University Bochum, Germany

⁹RIKEN Brain Science Institute, Wako, Japan

¹⁰Medical Faculty, RWTH University Aachen, Germany

NEST is a widely used tool to simulate biological spiking neural networks [1]. The simulator is subject to continuous development, which is driven by the requirements of the current neuroscientific questions. At present, a major part of the software development focuses on the improvement of the simulator's fundamental data structures in order to enable brain-scale simulations on supercomputers such as the Blue Gene system in Jülich and the K computer in Kobe. Based on our memory-usage model [2], we redesigned the neuronal and the connection infrastructure of NEST such that networks of 10^8 neurons and 10^{12} synapses can be simulated on the K computer [3]. These improvements reduce the memory footprint without compromising on the simulator's general usability and user interface. Here, we describe the recent technological advances which enable NEST to achieve high performance and good scaling of network setup and simulation on the K computer and on the Blue Gene system. We demonstrate that the usability of these machines for network simulations has become comparable to running simulations on a single PC.

Acknowledgements

Partly supported by the early access to the K computer at the RIKEN Advanced Institute for Computational Science, by the VSR computation time grant JINB33 on the JUGENE supercomputer in Jülich, the Helmholtz Alliance on Systems Biology, the Initiative and Networking Fund of the Helmholtz Association, the Helmholtz Association in the Portfolio theme "Supercomputing and Modeling for the Human Brain" and the Jülich Aachen Research Alliance (JARA), the Next-Generation Supercomputer Project of MEXT, and EU Grant 269921 (BrainScaleS). All network simulations carried out with NEST (<http://www.nest-initiative.org>).

References

1. Gewaltig & Diesmann (2007) Scholarpedia 2, 1430
2. Kunkel et al. (2012) Front. Neuroinform. 5:35

Synaptic Theta Susceptibility in Spike Timing Dependent Plasticity

Christian Albers, Klaus Richard Pawelzik¹

¹University of Bremen, Institute of Theoretical Physics, Hochschulring 18, 28359 Bremen, Germany

Synaptic plasticity likely is a key neural substrate underlying learning and memory in the brain. One activity-dependent synaptic learning rule is Spike Timing Dependent Plasticity (STDP), which is defined as the change of synaptic efficacy in response to pairs of pre- and postsynaptic spike (one each, repeated presentation). However, the effect of the spikes in complex spike patterns on synaptic changes is not yet well understood. Furthermore, it appears that not only individual spikes or spike pairs represent relevant signals for synaptic changes, but also periodic modulations of the firing rate, as evidenced by the importance of theta band oscillation in LFP or EEG for learning found in experimental studies. Here, we present a model of synaptic plasticity, which captures the dynamically varying contributions from each action potential in arbitrary spike patterns to weight changes thereby reproducing several experiments. The formulation of this contribution dynamics (CD) model also allows its application to arbitrary time courses of firing rates of the pre- and postsynaptic neuron which we used to investigate the susceptibility of a synapse to sinusoidal oscillations of pre- and postsynaptic firing rates. In other words, we investigated the weight change as a function of the common oscillation frequency and the phase difference between the presynaptic and the postsynaptic activities. We find that both, spike-pair based STDP as well as the contribution dynamics model for experimentally determined parameters exhibit maximal susceptibility of weight changes for firing rate oscillations in the theta band (4-10 Hz). In contrast to spike-pair STDP, the more general contribution dynamics model predicts that theta oscillations with zero phase lag between pre- and postsynaptic neurons will lead to a BCM like characteristic of the weight change as a function of the average firing rate, where the threshold of BCM theory decreases with increasing oscillation strength. Thereby, our model suggests that global theta oscillations may act as a reward signal which specifically potentiates synapses that connect pairs of excited neurons only.

Symmetry breaking in populations of neuronal feature detectors

Julia Hillmann, Robert Gütig¹

¹Max Planck Institute of Experimental Medicine, Theoretical Neuroscience, Hermann-Rein-Str. 3, 37075 Göttingen, Germany

Many neurons in sensory pathways respond selectively to a narrow class of stimuli such as faces or specific communication calls. At the same time neuronal processing is robust to a large degree of natural variability within such complex stimulus classes. For instance, face detection must be robust with respect to a particular hair or eye color and speech processing must tolerate large differences between female and male vocalizations. It is hypothesized that such difficult perceptual invariances might be subserved by populations of neurons that specialize on different substructures within a sensory object category. However, it is unclear what neuronal mechanisms could underly such symmetry breaking within a populations of sensory neurons.

In machine learning, ensemble methods for populations of neuronal detectors exist, but they commonly do not utilize direct interactions between neurons. While in bagging, neurons are trained independently on separate but fixed subsets of the training data, boosting entails the reweighting of examples for each individual neuron on the basis of the aggregate population performance. Here we propose the tagging (temporal aggregate) algorithm as a biologically plausible iterative population method aimed at inducing symmetry breaking and specialization within plastic neuronal networks.

For a given classification problem, we simulate a neuronal population of fixed size whose task is to discriminate target patterns from a null class. When a stimulus sample is presented during training, individual responses are generated and the decision of the population is based on the number of responding neurons. In the tagging learning rule, competition within the population is induced by allowing only one neuron after each error trial to update its weights. The selected neuron is the one closest to switching its individual response in the correct direction. All other cells, even if they 'missed' a target on the individual level or responded erroneously, remain unmodified. By not requiring each neuron to learn every stimulus example in the training set, we encourage symmetry breaking within the decoding population. As a result individual cells can specialize on different hidden subclasses within the stimulus class.

We investigate the behavior of this algorithm based on tempotrons, a biologically plausible neuron model that processes spatio-temporal spike trains[1]. In simulations with data sets composed of known subclasses, the structure of the data could be recovered by one-to-one mapping of the neurons, leading to an enhanced classification performance. Moreover, if no subclasses were incorporated in the target class by construction, specialization of the population members emerged on the basis of internal spike-latency structures (see Figure for an example of two neurons specializing on the early and late arriving input spike latencies). These findings demonstrate that the tagging algorithm is capable of automatically uncovering and exploit hidden structures in the input spike trains without the help of external supervision. We investigate the classification performance and specialization ability of the tagging population for different parameter settings and classification problems. Furthermore, we apply the algorithm to the problem of auditory word discrimination, where male and female voices may serve as subgroups.

[1] Gütig R. & Sompolinsky H. (2006). The tempotron: a neuron that learns spike timing-based decisions. *Nat. Neurosci.* 3, 420-428.

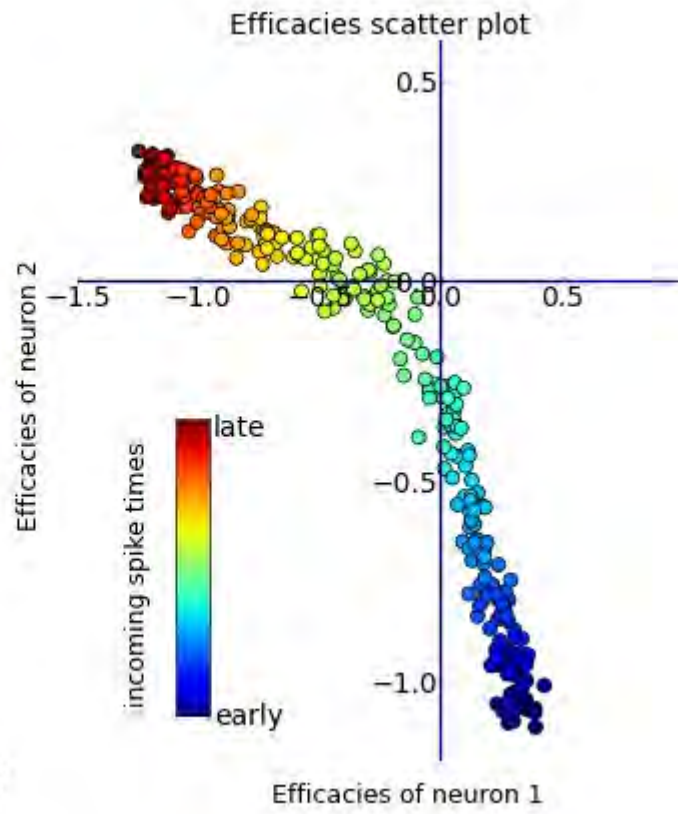
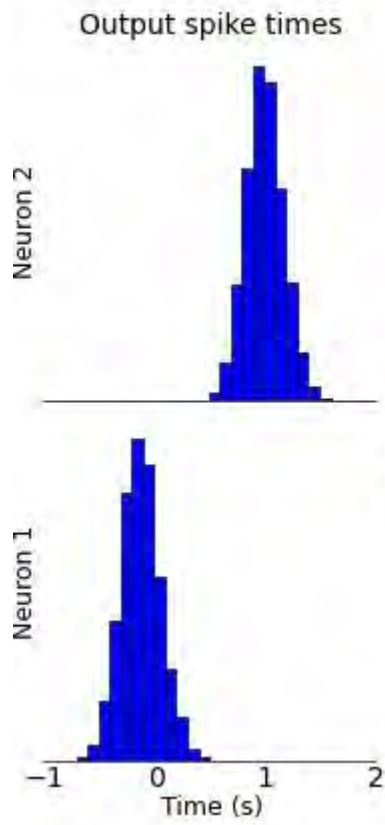

Compact Internal Representation - A Mathematical Model of *Drosophila*'s Prediction Capabilities in Flight Control

Bianca Zaepf, José Antonio Villacorta Villacorta², Jan-Lukas Oepen¹, Roland Strauss¹

¹Johannes Gutenberg-University, Institute of Zoology - Neurobiology, Colonel-Kleinmann-Weg 2, 55099 Mainz, Germany;

²Universidad Complutense de Madrid, Departamento de Matemática Aplicada, Plaza de las Ciencias, 3, 28040 Madrid, Spain

Easily one can imagine, how difficult it must be for a flying fly to navigate in an environment rich of moving objects. How to avoid collisions and make a soft landing, when for instance seesawing plants provide ample distraction? Flies have to rely on their sensory systems to survive, but the information they perceive is rich and complex. Remarkably, flies show prediction capabilities, when their environment changes in a regular manner with time.

The aim of this project is to investigate, how flies perform the processing of systematically time-dependent sensory information, and to find brain areas involved in the high-level processing of such information. We try to understand this information processing by starting from the mathematical concept of Compact Internal Representation (CIR).

CIR is based on two preconditions: First, the agent is able to predict the future progression of its environment and second, the agent will understand the influence of its own movements on the predicted environmental progression. With the same visual input, the behaviour of flies at a flight simulator will be compared to the predictions of the CIR model.

For this purpose we are monitoring the flies' responses to moving landmarks during stationary flight in a flight-simulator (wingbeat-processor, Götz 1968), where the differences in stroke amplitudes of the right (R) and left wing (L) are used as a measure for intended changes in flight direction. The wingbeat analyser captures the shadows of the wings during stationary flight casted by infrared diodes. The flies are surrounded by a cylindrical arena consisting of optical fibres, which display a 280° panorama from a flat computer screen.

Wild-type flies can follow precisely a moving landmark, even when this landmark disappears spontaneously behind a screen up to 40° width. But how can one distinguish between a passive continuation of the current flight direction and true prediction behaviour? In experiments, during which a continuously rotating landmark was shown to the flies for 10 full rotations before a screen appeared, the flies did not follow the hidden landmark in this first instance after training. This outcome points to prediction rather than passive continuation. Furthermore, flies which have lost their mushroom bodies due to chemical ablation do show passive continuation of their flight direction. They have problems to change their flight direction in an adaptive manner. Earlier experiments had shown, that the ellipsoid body and the protocerebral bridge are involved in various aspects of flight control (Ilius et al. 1994; Strauss et al. 1992), like anticipation behaviour in landmark fixation, and the time to optomotor reversal in a striped drum, which regularly switched the direction of rotation. The CIR-Model should help to understand the high-level processing of sensory information in the fly brain.

This work is kindly supported by the EU project EMICAB (FP7-ICT, No.270182) "Embodied Motion Intelligence for Cognitive, Autonomous Robots". For more information visit <http://www.emicab.eu>

References:

Götz, KG (1968) *Kybernetik* 4(6): 199-208.

Ilius et al. (1994) *J. Neurogenet.* 9(3): 189-206.

Strauss et al. (1992) J. Neurogenet. 8(3): 125-155.

Linking physiology and morphology in two types of honeybee projection neurons.

Anneke Meyer, Martin F. Brill¹, Wolfgang Rössler¹, Martin Paul Nawrot²

¹Uni Würzburg, Department of Behavioral Physiology & Sociobiology, Biozentrum Uni Würzburg, Am Hubland, 97074 Würzburg, Germany

²FU Berlin, Department of Neurobiology, Institute of Biology, Koenigin Luise Str. 1-3, 14195 Berlin, Germany

It is widely acknowledged that a neuron's function is reflected in both, its morphology and its electrophysiological properties. However it is very difficult to conclude from either of these two characteristics to the other one. Here we use hierarchical clustering and machine learning to explore differences between two types of projection neurons (PNs) in the honey bee antennal lobe (AL). These morphologically similar neuron families leave the AL via different tracts, the lateral (l-APT PNs) and the medial Antennocerebral Tract (m-APT PNs). The existence of these two separated pathways suggests functional differences between its neurons. But is this assumption supported by systematic differences in electrophysiological properties? And if so, which properties are most helpful to separate m-APT PNs from l-APT PNs?

We analyzed data from 122 extracellularly recorded AL units, which, based on electrode placement were unambiguously identified as belonging to the m- or the l-APT [1]. For each unit well established measures of electrophysiological response activity (features) were estimated. To find the set of features which most efficiently describes the difference between units from l- and m-tract, we performed hierarchical clustering (Euclidian distances, Wards linkage) based on the principal components (PCs) of every possible combination of properties. We validated the resulting set of features by sorting neurons using a support vector machine (SVM) as an alternative approach.

We find that significant between-group differences exist for individual features. Alone however, none of these features suffices to classify l-APT and m-APT units. Clustering by means of electrophysiological properties separates l-APT units and m-APT units significantly above chance level (Matthews correlation coefficient 0.47, chance level 0.19). The features which contributed most to the separation of units from different tracts were CV2 (a measure of spike time irregularity), Fano-factor (spike count variability), spontaneous firing rate and a unit's lifetime sparseness (odor tuning width). Sorting units with a support vector machine (SVM) approach performed superior to hierarchical clustering (Matthews correlation coefficient 0.65). Measures which contributed to the SVM-model were again, CV2, Fano-factor and measures of firing rate.

Our results indicate that electrophysiological properties of units from the l-APT and the m-APT show subtle differences in characteristic electrophysiological properties. What has been described often a times phenomenologically, are differences in odor specificity, firing frequency and sometimes rate profiles [2,3,4]. These phenomena are well captured in those properties we identified as best separators: life time sparseness (odor specificity), CV2 (spike time irregularity), Fano-factor and rate measures (frequency and profile). We conclude that hierarchical clustering is a useful tool to identify properties of electrophysiological activity, which efficiently describe differences between morphologically distinct PNs. SVMs offers a superior method to predict PN morphology from electrophysiology.

Acknowledgements

Funding was received from the German Federal Ministry of Education and Research (BMBF) through

grant "01GQ0941" to the Bernstein Focus Neuronal Basis of Learning (BFNL), and from the Deutsche Forschungs Gemeinschaft (DFG) SPP 1392 (RO 1177/5-1).

Conflict of Interest

References

- [1] Martin FB, Rosenbaum T, Reus I, Kleineidam CJ, Nawrot MP, Rössler W (2012). Submitted to J.Neurosci
- [2] Müller D, Abel R, Brandt R, Zöckler M, Menzel R (2002). J Comp Physiol A, 88(5):359-70
- [3] Krofczik S, Menzel R and Nawrot MP (2008). Front Comput Neurosci.2:9
- [4] Carcaud J, Hill T, Giurfa M and Sandoz JC (2012). J Neurophysiol. 108(4):1106-21

Dependence of neuronal encoding on the site of action potential initiation

Maxim Volgushev, Evgeny Nikitin², Vladimir Ilin¹

¹University of Connecticut, Psychology, 406 Babbidge Rd, 06269 Storrs, USA

²Inst. of Higher Nervous Activity and Neurophysiology Russian Academy of Sciences, Moscow, Russian Federation

Populations of neocortical neurons can encode rapidly changing signals and respond to subtle inputs fast, within few ms. Theoretical studies attributed such coding properties to action potential (AP) generators with fast onset dynamics. However, prior theoretical analysis addressed the AP encoding in single-compartment models, where the synaptic input, AP generation and recording all take place at the same site. In neocortical neurons however, changes of the membrane potential produced by incoming inputs and the APs are usually recorded in the soma, while initiation of the APs takes place in the axon initial segment (AIS), at some distance from the recording site. To understand how the distant AP initiation affects neuronal encoding we used a combination of whole cell recording and optical imaging in layer 5 pyramidal neurons in slices of rat visual cortex and computer simulations. Optical imaging experiments with voltage-sensitive dyes demonstrated, in agreement with prior studies, that the APs in layer 5 pyramidal neurons were initiated in the AIS, ~50-55 μm away from the soma. Frequency response function of layer 5 pyramidal neurons was measured using responses to injection of fluctuating current. These measurements showed that layer 5 pyramidal neurons can encode input frequencies up to ~500-600 Hz. For computer simulations, we have constructed two families of multicompartmental neuron models in which the site of APs initiation was systematically shifted. In the first family of models, sodium channels with Hodgkin-Huxley (HH) type channels were implemented in all compartments. In the second family, a small fraction (10%) of sodium channels with threshold-like activation was added at the site of AP initiation, all other sodium channels had HH type kinetics. Both families included models with the sites of AP initiation in the soma, the axon hillock, proximal or distal axon initial segment and 1st to 4th node of Ranvier. Initiation of the APs in a particular compartment of the model was achieved by shifting the midpoint of activation of sodium channels by 8-10 mV towards more hyperpolarized values and a moderate increase of sodium channels density at this compartment. All other parameters were the same in all models. A shift of the AP initiation site had differential effects in the models incorporating sodium channels of HH type kinetics or those with threshold activation. In the models with HH type channels the encoding of high frequencies was improved when AP initiation site was shifted from the soma to the distal AIS or the first node of Ranvier, but deteriorated with further shift to the 2nd - 4th nodes. However, even with the optimal location of AP initiation site (at 50-120 μm from the soma), the encoding of high frequencies in HH type models was significantly inferior to that measured in real neurons. In contrast, the models with a small fraction (10%) of threshold channels at the initiation site encoded high frequencies better than the neurons. This holds for the tested range of frequencies (up to 1000 Hz) and initiation in the soma, AIS and up to the 4th node of Ranvier (260 μm from the soma). With the shift of the AP initiation site beyond the distal AIS (60 μm from the soma) models with a fraction of threshold channels exhibited a slight attenuation of encoding of high frequencies, most probably due to passive filtering of membrane potential fluctuations on their way from the soma to the AP initiation site.

Detection of single sources during cognitive processing of auditory stimuli

Ralf Mueller, Max Taubert¹, Marco Weiergräber², Joachim Klosterkötter¹, Stephan Ruhrmann¹, Anke Brockhaus-Dumke³

¹University of Cologne, Cologne Cognitive Neurophysiology Lab (CCNL), Department of Psychiatry and Psychotherapy, Kerpener Straße 62, 50924 Cologne, Germany

²Federal Institute for Drugs and Medical Devices (Bundesinstitut für Arzneimittel und Medizinprodukte, BfArM), Cellular and Systemic Neurophysiology, Kurt-Georg-Kiesinger-Allee 3, 53175 Bonn, Germany

³Rheinessen-Fachklinik Alzey, Department of Psychiatry, Psychotherapy and Psychosomatics Medicine, Dautenheimer Landstraße 66, 55232 Alzey, Germany

Recording of EEG in humans results in a huge amount of summed local field potentials. Localization of the origins of neural activity is required for understanding the underlying physiology and in a clinical context the pathophysiology. Especially, the search for sources of neural activity reflecting cognitive processing in the millisecond range is the ultimate goal, since preattentive auditory processing followed by simple cognitive decisions is already completed after a short time range of about 150 milliseconds after stimulus presentation. Therefore, the first step is a classification of such sources, which definitely arise in the auditory cortex. These sources must be distinguished from neural processes, which occur at the same time but are located in other regions of the brain.

The high time resolution of the EEG is perfectly suited for millisecond-precise analysis of ongoing neural processes. Additionally, mathematical algorithms and source analysis techniques are used to adequately compute the location and the amplitude of the auditory sources. Source analysis algorithms developed so far suffer from inaccuracy of these variables which are due to the low signal to noise ratio regarding single sources.

We developed an advanced mathematical algorithm to reliably compute amplitude and location of sources from the auditory stream during the presence of other disturbing processes, which occur during ordinary cognitive processing of auditory stimuli.

Temperature compensated responses in conductance-based models of grasshopper auditory receptors: Ionic mechanisms and metabolic cost

Frederic Roemschied, Jan-Hendrik Schleimer¹, Monika Eberhard², Bernhard Ronacher², Susanne Schreiber¹

¹Institut für Theoretische Biologie, Computational Neurophysiology, Invalidenstraße 43, 10115 Berlin, Germany

²Institut für Biologie, Verhaltensphysiologie, Invalidenstraße 43, 10115 Berlin, Germany

The kinetics of ion-channels in a neuron's membrane depend on temperature. Consequently, the response properties of receptor neurons are affected by changes in body temperature. This particularly affects poikilothermic animals that need to maintain their behavioral function in habitats with significant variation in temperature conditions through out the day. We investigated the temperature dependence of neural processing in the grasshopper's auditory system by a combination of electrophysiological recordings modeling.

We found that the firing rate responses of the primary auditory receptor (PAR) of grasshoppers are remarkably unaffected by temperature.

The PAR of grasshoppers is a bipolar neuron, attached to the tympanic membrane. It contains both the transduction mechanism and a spike generation zone. These neurons constitute the input layer to the feed-forward network in the metathoracic ganglion. As no feedback connections are known the observed temperature compensation must arise from PAR-intrinsic properties.

Two possible mechanisms can be identified: (I) separate temperature compensation of both transduction and spike generation; and (II) the spike generating mechanism compensates the temperature dependence of the transduction process and vice versa.

We show how the temperature sensitivities of the different ionic currents involved in spike generation can be combined to optimize temperature invariance. In particular, the temperature dependences of the model's potassium conductances were identified as the important parameters in shaping temperature robustness in the spike rate.

We ask whether this neuron-intrinsic compensation mechanism is accompanied with an increased metabolic cost, defined as the total sodium current per action potential. We found that the metabolic cost is mostly governed by sodium inactivation. Our finding shows that disjunct set of parameters in the model impact on the two objectives temperature compensation on the one hand and metabolic efficiency on the other hand. We can conclude that the a neuron could be optimized for the two objectives without strong compromises.

An other view on the problem of coding in temperature varying systems is given by the Fisher information of the stimulus response curves. From this analysis we conclude that the influence of the temperature beyond changes in the mean spike rate are important. We suggest that the temperature dependence of the spike-rate variance in the spike-generation mechanism as well as the current fluctuations produced by the transduction mechanism may be decisive in understanding which mechanism (I) or (II) is favorable for the animal.

We have shown that temperature-compensated spike rates and metabolically efficient action potentials can coexist in a single neuron, because the respective cell-intrinsic mechanisms are mediated by different sets of ionic conductances. This is an important finding because the spike rates of the PAR are generally high, constituting a more substantial contribution to the total energy cost of the nervous system than consecutive stages in the sensory pathway where responses are sparser.

Learning lateral inhibition with inhibitory spike-timing dependent plasticity to improve stimulus discrimination in a model of the antennal lobe

Bahadir Kasap, Michael Schmuker^{1,3}

¹Neuroinformatics & Theoretical Neuroscience, Dept. of Biology Chemistry Pharmacy, Freie Universität Berlin, Germany

²Institute for Computational Mathematics, Carl-Friedrich-Gauss-Dept., Technische Universität Braunschweig, Germany

³Bernstein Center for Computational Neuroscience Berlin, Germany

The insect olfactory system is capable of classifying odorants by encoding and processing the neural representations of chemical stimuli. Odors are transformed into a neuronal representation by a number of receptor classes, each of which encodes a certain combination of chemical features. Those representations resemble a multivariate representation of the stimulus space (Huerta and Nowotny, 2009). The insect olfactory system thus provides an efficient basis for bio-inspired computational methods to process and classify multivariate data. In previous work, we demonstrated how a network inspired by the insect olfactory system improves classification of multivariate data by lateral inhibition (Schmuker and Schneider, 2007). In that study, the connectivity of lateral inhibition was chosen such that glomeruli with similar response profiles shared strong mutual inhibition, increasing their contrast and thus improving stimulus separability.

Here, we propose an approach to learn the connectivity of lateral inhibition through unsupervised learning of rate correlations in the input by inhibitory spike-timing dependent plasticity (iSTDP, Vogels *et al.*, 2011). To this end, we implemented a spiking network model of the insect antennal lobe with lateral inhibitory connections that support iSTDP. We exposed the network to stimulus patterns with structured firing rate correlation between input channels, similar to input patterns generated by olfactory receptors with partially overlapping receptive fields. As a consequence of iSTDP, the network's inhibitory connectivity converged towards an accurate reflection of the correlation structure in the input data. Moreover, the network efficiently reduced firing rate correlation at the output, potentially improving the separability of stimuli for improved discrimination. Thus, iSTDP in our network model asserts decorrelation of the input data without *a priori* information on the input. Our results indicate that iSTDP is a suitable mechanism to improve stimulus separability in the insect antennal lobe. Moreover, our network model is suited as a building block for bio-inspired data analysis frameworks, for example on a neuromorphic hardware system supporting spiking neural network models (Schemmel *et al.*, 2006).

This was partially funded by the German Ministry for Education and Research (BCCN Berlin, 01GQ1001D) and Deutsche Forschungsgemeinschaft (SCHM 2474/1-1).

References

Huerta R & Nowotny T (2009). Fast and Robust Learning by Reinforcement Signals: Explorations in the Insect Brain. *Neural Comput.* 21:2123–2151.

Schmuker M & Schneider G (2007). Processing and classification of chemical data inspired by insect olfaction. *PNAS* 104:20285–20289.

Vogels TP, Sprekeler H, Zenke F, Clopath C & Gerstner W (2011). Inhibitory plasticity balances excitation and inhibition in sensory pathways and memory networks. *Science* 334: 1569–1573.

Schemmel J, Gruebl A, Meier K & Mueller E (2006). Implementing Synaptic Plasticity in a VLSI Spiking Neural Network Model. In *Proc. IJCNN 2006*, p. 1-6. IEEE press.

Receptive Field Inference from Binary Spike Decisions for Responses to Non-Gaussian Stimulus Ensembles

Arne-Freerk Meyer, Jan-Philipp Diepenbrock², Frank W. Ohl³, Jörn Anemüller¹

¹Institute of Physics, Carl von Ossietzky University of Oldenburg, Oldenburg, Germany

²Leibniz Institute for Neurobiology, Magdeburg, Germany

³Institute of Biology, Otto-von-Guericke University, Magdeburg, Germany

Introduction

The receptive field (RF) represents a classic approach to the characterization of sensory neurons through a linear filter. The underlying neuronal model consists of a linear non-linear cascade model that drives a spike-generating Poisson process [1]. When computed with stimuli that are non-white or non-Gaussian, in particular natural stimuli, standard RF estimation methods like the spike-triggered average (STA) and variations thereof have been shown to result in biased estimates of the true receptive field.

Recently developed RF estimation methods include semi-parametric information theoretic approaches that in theory allow for unbiased RF estimates independent of stimulus statistics and neural response nonlinearity [2]. However, numerical optimization of the underlying non-convex objective functions is non-trivial in practice. It results in comparably high variance of obtained RF estimates, in particular when available data is of limited length.

Model and algorithm

The approach pursued here assumes the well-known neuron model of a weighted linear integrator with a noisy threshold operation, which together determine the spike/non-spike response. In stimulus input space, a hyperplane defined by linear filter and threshold value optimally separates spike-eliciting stimulus examples from non-spike-eliciting ones.

We propose to estimate this optimal hyperplane using a support vector machine (SVM) classifier and show that this is equivalent to estimating the neuron's linear receptive field. In contrast to STA-based estimators, the approach does not make any assumptions regarding multivariate stimulus distribution or correlation structure of the stimulus ensemble. In contrast to information theoretic approaches, optimization is performed on a well-behaved convex goal function. We show how robust regularization and spike/non-spike class-prior information may be incorporated into the model, leading to a non-standard formulation of the SVM. The resulting method bears qualitative similarities to maximization of mutual information between stimulus and response while maintaining the advantage of convex optimization.

Experiments and Results

Using simulated responses, we demonstrate that the proposed approach is robust to asymmetric (non-Gaussian) stimulus distributions and second- and higher-order correlations in the stimulus ensemble. Findings are verified by estimation of spectro-temporal receptive fields (STRFs) for the inferior colliculus of mongolian gerbils, recorded in response to auditory stimuli. In the large data regime, the presented approach performs equal to unbiased information-theoretic estimators. With limited amounts of data, it

exhibits significantly smaller variance of the obtained RF estimates. The method may permit more accurate investigation of neural effects such as adaptation that occur on smaller time scales than common RF estimators require to converge.

References

- [1] EJ Chichilnisky: A simple white noise analysis of neuronal light responses. *Network, Systems Neurobiology*, 2001, 12, 199-213.
- [2] T Sharpee, NC Rust & W Bialek: Analyzing neural responses to natural signals: maximally informative dimensions. *Neural Computation*, 2004, 16, 223-250.
- [3] AF Meyer, MFK Happel, FW Ohi & J Anemüller: Estimation of spectro-temporal receptive fields based on linear support vector machine classification *BMC Neuroscience*, 2009, 10, P147.

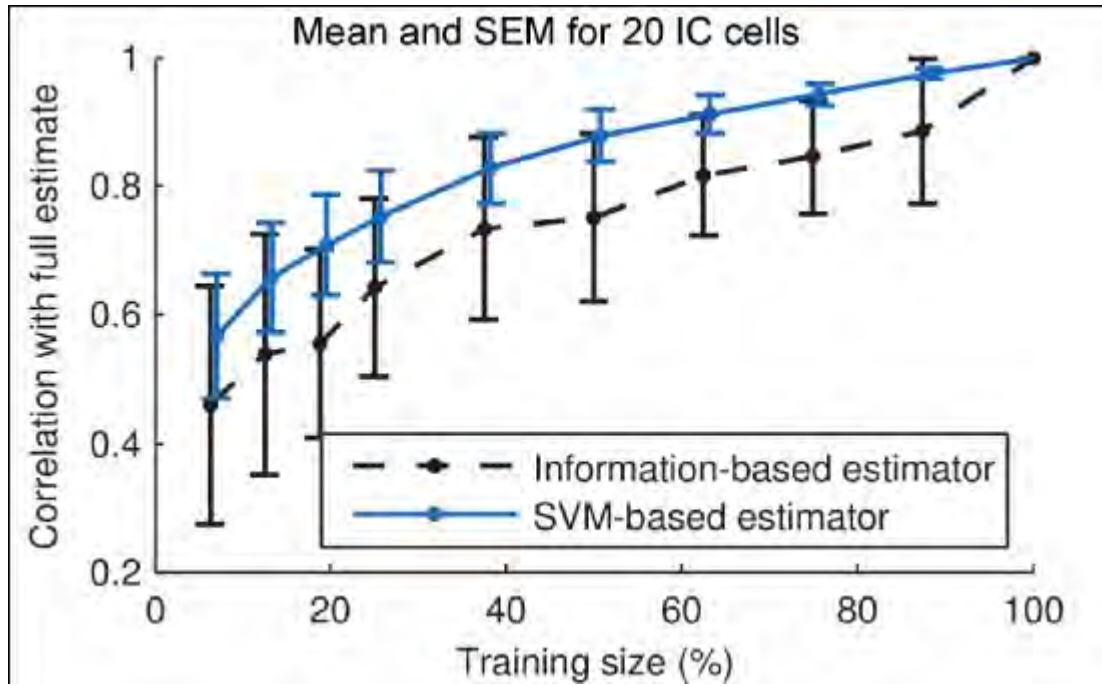

A dynamic model for selective visual attention predicts information routing

Daniel Harnack, Udo A Ernst¹, Klaus R Pawelzik¹

¹University of Bremen, Theoretical Neurophysics, Hochschulring 18, 28359 Bremen, Germany

A remarkable feature of the brain is its ability to flexibly process information in a context-dependent manner. For example, selective attention allows to focus on relevant information, and to ignore distracting features of a visual scene. Here we develop a model to investigate a putative neural mechanism by which attention might dynamically change the functional configuration of networks in visual cortex.

Since efferents from multiple neurons in an early visual area converge onto the same neuron in a higher area, synaptic input induced by an attended object should be more efficient in driving the postsynaptic neuron than inputs induced by unattended objects. In fact, it has been found (I) that the firing rate of a postsynaptic neuron is similar to its activity when the unattended stimulus is absent (biased competition). Attention is thus assumed to selectively promote information transfer between visual areas. Recent experiments support this idea by showing (II) that the V4 local field potentials are correlated with a temporal modulation of the attended stimulus, and not with the non-attended stimulus in the same receptive field.

We construct a biophysically plausible model that reproduces both experimental results within the same framework. It comprises four populations of recurrently coupled networks of conductance-based spiking neurons with lateral inhibition. The first two networks correspond to a lower visual area with nonoverlapping RFs, which both project to the third and the fourth network corresponding to higher area populations with larger RFs. We assume attention to manifest as an additional input to one lower area population. Deployment of attention results in a biased competition effect of the firing rate (I), and in selective gating of information flow (II). We thus propose a combination of cortical network topology, neuronal population dynamics, and selective additional input as putative neural underpinnings of attention.

Neurophysiological validation of computational methods to predict cortical excitation volumes in transcranial magnetic stimulation

Alexander Opitz, Wynn Legon², Abby Rowlands², Walter Paulus¹, William J. Tyler²

¹University Goettingen, Clinical Neurophysiology, Robert Koch Strasse 40, 37075 Goettingen, Germany

²Virginia Tech Carilion Research Institute, Roanoke, VA, USA

TMS is now widely used in research and holds therapeutic promise. Nevertheless there remains a high degree of variability in the effects reported across subjects, studies and treatment paradigms. Recently, computational approaches using realistic finite element models (FEM) of the brain have enabled more accurate estimations of the electric fields generated during TMS protocols. These models help to differentiate between interindividual TMS variability due to gyral folding patterns and other confounds such as subject-specific conductivity anisotropy. Validation approaches of FEM-simulated electric fields induced by TMS by actual physiological responses, such as motor evoked potential (MEP) amplitudes are scarce. Here, we compared computational predictions with MR-guided TMS motor-mapping and fMRI. Anatomical voxel based, diffusion weighted imaging (DTI) and functional MRI was conducted on all subjects. An individual FEM model including conductivity anisotropy derived from DTI data was generated for each subject. We measured MRI-guided TMS-evoked MEP from four different muscles (FDI, ADM, ECR, FCR). The motor cortex was mapped at different locations with 1 cm spacing using 5x5 cm grids centered on the subject's motor hot-spot for a given muscle. At each stimulus site, we evoked MEPs using two different TMS coil orientations (45° to midline and 90° to midline). For each coil position, FEM simulations of the TMS-induced electric field were generated and compared with TMS-evoked MEP amplitudes. FEM simulations reliably predicted these MEP maps for the two given TMS orientations, although MEP amplitude maps differed significantly in spatial extent and amplitude across coil orientations. We conclude that taking subject-specific electric field distributions into account can improve our understanding of the variability of physiological measurements obtained during various TMS protocols. Furthermore, combining fMRI with FEM simulations may enhance the precision of targeting of brain circuits such as the dlPFC, which do not exhibit immediate behavioral responses to TMS.

Somatic sodium channels account for 2nd phase of action potential upstroke in layer 5 pyramidal cells

Andreas Neef, Michael J Gutnick², Fred Wolf³, Ilya Fleidervish⁴

¹Universitätsmedizin Göttingen, HNO, Robert-Koch-Str. 40, 37075 Göttingen, Germany

²Hebrew University, Koret School of Veterinary Medicine, Rehovot, Israel

³MPI for Dynamics and Self-Organization, Göttingen, Germany

⁴Ben Gurion University of the Negev, Beer Sheva, Israel

Mechanisms of action potential (AP) generation in neocortical pyramidal cells have been the focus of intense experimental and theoretical research over the last several decades. It has proven very difficult, however, to arrive at a consensus model which can satisfactorily account for all of its features. One of the still unresolved issues is lack of accurate description of Na⁺ channel kinetics in different neuronal compartments. Here, we measured kinetics of somatic Na⁺ channels using high temporal resolution (5-10 kHz, -3dB, low pass four-pole Bessel filter) cell-attached recordings from layer 5 pyramidal neurons in neocortical slices. The data were described by fitting different Markov models with differential evolution fit algorithms. The limited speed of voltage steps and the effect of current filtering were accounted for in the fit procedure. Activation kinetics was best described by Markov models with two sequentially activating gates, while inactivation was best described as a process that runs in parallel to activation. The best model described the channel data well enough to allow quantitative prediction of the somatic Na⁺ current during the somatic spike. To this end the AP waveform recorded in current clamp in the same preparation, was used to drive Na⁺ channels in the model. The resulting simulated current matched the second phase of the AP upstroke in the phase plot (dV/dt vs V). This is consistent with the long standing idea that somatic Na⁺ channels are the main current sink during this second phase of the AP upstroke but contribute little to its initial phase. Besides a precise description of sodium channel activation kinetics, these measurements also provide independent lower bounds on the somatic sodium channel density of about 10 channels per micrometer square.

Supported by the GIF and the BMBF (BCCN, Goettingen)

Sparse and reliable cortical representations emerge naturally in networks with adapting neurons.

Martin Paul Nawrot, Farzad Farkhooi¹

¹Freie Universität Berlin, Theoretical Neuroscience, Institute of Biology, Königin Luise Straße 1-3, 14195 Berlin, Germany

Action potential induced adaptation is an ubiquitous phenomenon in spiking neurons, both in peripheral and central nervous systems (Wark, Lundstrom & Fairhall, 2007). How cellular adaptation affects neural processing at the network level remained largely unexplored. Here, we investigate the role of adaptation on the progressive stimulus representation from peripheral to central stages in the sensory pathway. We report two important results. (1) Neuron-intrinsic adaptation causes a *transient reduction of the trial-by-trial variability* of cortical neurons (under balanced network conditions) and thus provides a qualitative and quantitative explanation for a wide-spread and yet unexplained phenomenon that has been experimentally verified in sensory and central areas (Churchland et al., 2010) as well as in motor areas (e.g. Churchland et al., 2006; Rickert et al., 2009). This reduction in variability in single neuron output transfers to the population activity, which implies reliable input to downstream neurons (Farkhooi, Müller & Nawrot, 2011). (2) The effect of cellular adaptation accumulates across successive network stages. Each transmission step *increases the temporal sparseness of the response*. An adaptive cortical ensemble receiving input from a sub-cortical group of adaptive neurons responds with a single or only very few spikes to the onset of a constant stimulus with high precision. We hypothesize that this mechanism facilitates assembly formation and could be used by the system for transforming a rate code into a temporal code.

This research is funded by the German Federal Ministry of Education and Research (BMBF) within the Bernstein Focus Neuronal Basis of Learning through grant 01GQ0941.

Churchland MM, Yu BM, Ryu SI, Santhanam G, Shenoy KV (2006) Neural Variability in Premotor Cortex Provides a Signature of Motor Preparation. *J Neurosci* 26: 3697-3712

Churchland MM, et al. (2010) Stimulus onset quenches neural variability: a widespread cortical phenomenon. *Nat Neurosci* 13: 369-78

Farkhooi F, Müller E, Nawrot MP (2011) Adaptation reduces variability of the neuronal population code. *Physical Review E* 83: 050905

Rickert J, Riehle A, Aertsen A, Rotter S, Nawrot MP (2009) Dynamic encoding of movement direction in motor cortical neurons. *Journal of Neuroscience* 29: 13870-13882

Wark B, Lundstrom B, Fairhall A (2007) Sensory adaptation. *Current opinion in neurobiology* 17: 423-29

Synaptic Scaling enables Dynamically Distinct Short- and Long-Term Memory Formation

Christian Tetzlaff, Christoph Kolodziejcki^{1,3,4}, Marc Timme^{1,3,4}, Misha Tsodyks⁵,
Florentin Wörgötter^{2,4}

¹Max Planck Institute for Dynamics and Self-Organization, Network Dynamics Group, Am Fassberg 17, 37077 Göttingen, Germany

²Faculty of Physics - University of Göttingen, Computational Neuroscience - Biophysics, Friedrich-Hund Platz 1, 37077 Göttingen, Germany

³Faculty of Physics - University of Göttingen, Nonlinear Dynamics, Friedrich-Hund Platz 1, 37077 Göttingen, Germany

⁴University of Göttingen, Bernstein Center for Computational Neuroscience, Friedrich-Hund Platz 1, 37077 Göttingen, Germany

⁵Weizmann Institute of Science, Department of Neurobiology, 234 Herzl St., Rehovot 76100, Israel

Memory formation in the nervous system relies on mechanisms acting on time scales from minutes, for long-term synaptic plasticity (Bliss and Lomo, 1973; Bi and Poo, 1998), to days, for memory consolidation (Dudai, 2004; 2012). During such processes, the neural network distinguishes synapses relevant for forming a long-term memory (LTM), which are consolidated, from synapses of short-term memory (STM), which fade. We show that neural circuits combining synaptic scaling (Turrigiano et al., 1998) with synaptic plasticity (Tetzlaff et al., 2011; 2012) naturally exhibit a transition from short- to long-term memory, where LTM-candidate synapses maintain their integrity through unspecific, "sleep-like" activation (Diekelmann and Born, 2010), while STM-candidates fade. Their distinct responses are system intrinsic and due to nonlinearities that induce a bifurcation arising from combined plasticity and scaling, and not requiring external interference with the natural dynamics of the system. Intriguingly, the dynamics of systems exhibiting such a bifurcation explain recent experimental results (Walker et al., 2003) on the apparently paradoxical effect of memory destabilization during reconsolidation (Nader et al., 2000; Tronson and Taylor, 2007), where the recall of a previously learnt aspect actually disrupts its memory. Our model does not attempt to implement any of the complex and still little understood mechanisms for systems consolidation (Dudai, 2004; 2012), which would lead to true long-lasting memories. Instead, this study presents a generic mechanism for dynamically maintaining synaptic integrity of LTM-candidates in the network. Thus, these results indicate that scaling may be fundamental for stabilizing memories, providing a dynamic link between early and late memory formation processes.

References:

- Bi GQ and Poo MM (1998). Synaptic modifications in cultured hippocampal neurons: dependence on spike timing, synaptic strength, and postsynaptic cell type. *J. Neurosci.*, 18(24):10464-10472.
- Bliss TVP and Lomo T (1973). Long-lasting potentiation of synaptic transmission in the dentate area of the anaesthetized rabbit following stimulation of the perforant path. *J. Physiol.*, 232: 331-356.
- Diekelmann S and Born J (2010). The memory function of sleep. *Nat. Rev. Neurosci.*, 11:114-126.
- Dudai Y (2004). The neurobiology of consolidation, or, how stable is the engram? *Annu. Rev. Psychol.*, 55:51-86.
- Dudai Y (2012). The restless engram: consolidation never end. *Annu. Rev. Neurosci.*, 35:227-247.
- Nader K, Schafe GE, and LeDoux JE (2000). Fear memories require protein synthesis in the amygdala for reconsolidation after retrieval. *Nature*, 406:722-726.
- Tetzlaff C, Kolodziejcki C, Timme M, and Wörgötter F (2011). Synaptic scaling in combination with many generic plasticity mechanisms stabilizes circuit connectivity. *Front. Comput. Neurosci.*, 5:47.

- Tetzlaff C, Kolodziejcki C, Timme M, and Wörgötter F (2012). Analysis of synaptic scaling in combination with Hebbian plasticity in several simple networks. *Front. Comput. Neurosci*, 6:36.
- Tronson NC and Taylor JR (2007). Molecular mechanisms of memory reconsolidation. *Nat. Rev. Neurosci.*, 8:262-275.
- Turrigiano GG, Leslie KR, Desai NS, Rutherford LC, and Nelson SB (1998). Activity-dependent scaling of quantal amplitude in neocortical neurons. *Nature*, 391: 892-896.
- Walker MP, Brakefield T, Hobson JA, and Stickgold R (2003). Dissociable stages of human memory consolidation and reconsolidation. *Nature*, 425:616-620.

Intrinsic and extrinsic sources of correlated activity in recurrent networks

Moritz Helias, Tom Tetzlaff¹, Markus Diesmann^{1,2}

¹Institute of Neuroscience and Medicine (INM-6),
Computational and Systems Neuroscience,
Jülich Research Center

²Medical Faculty,
RWTH Aachen University

If spike timing is used to store, convey, or process information, correlations between the spiking activity of pairs of neurons in the brain reveal insights about its inner workings. The presence of correlated neuronal activity as such is however not surprising, but rather a natural consequence of interacting neurons; either due to direct synaptic connections or by receiving input from common internal or external sources [1]. The intriguing feature are the changes of correlation in relation to behavior [2]. A theoretical understanding of correlations therefore requires the representation of: (1) the recurrent connectivity and (2) external and internal sources of temporally varying or fluctuating signals. Despite the rapid progress of recent years [3-6] after a decade of stagnation, such a theory is currently unavailable. In particular, it is still unclear how the recently found mechanism of active decorrelation [7], explained by negative population feedback [8], affects the response of network activity to externally applied stimuli. Here we extend the theory of correlations in binary networks [9] to external correlated input. We show that: (1) the structure of correlations [10] is mainly determined by the local recurrent connectivity, (2) common external inputs cause a correlation-shift, (3) inhibitory feedback effectively decorrelates neuronal activity, even if neurons receive identical external inputs, and (4) connectivity with approximately identical afferents to excitatory and inhibitory cells increases internally generated fluctuations and pairwise correlations. Our work provides a first stepping stone in the endeavor to understand the transformation of impinging correlated external activity into correlated activity between the neurons of the network.

Partially supported by the Helmholtz Alliance on Systems Biology, the Helmholtz Association in the Portfolio theme "Supercomputing and Modeling for the Human Brain", the Jülich Aachen Research Alliance (JARA), the Next-Generation Supercomputer Project of MEXT, and EU Grant 269921 (BrainScaleS).

2. BE Kilavik, S Roux, A Ponce-Alvarez, J Confais, S Gruen, A Riehle (2009), *Journal of Neuroscience*, 29:12653-12663
3. B Lindner, B Doiron, A Longtin (2005) *PRE*, 72:061919
4. S Ostojic, N Brunel (2011) *PLoS Comput Biol*, 7(1):e1001056
5. V Pernice, B Staude, S Cardanobile, S Rotter (2011) *PLoS Comput. Biol.*, 7(5):e1002059
6. J Trousdale, Y Hu, E Shea-Brown, and K Josic (2012) *PLoS Comput. Biol.*, 8(3):e1002408
7. A Renart, J de la Rocha, P Bartho, L Hollender, N Parga, A Reyes, KD Harris (2010) *Science*, 327:587-590
8. T Tetzlaff, M Helias, G Einevoll, M Diesmann (2012) *PLoS Comput. Biol.*, 8(8):e1002596.
9. I Ginzburg, H Sompolinsky (1994) *PRE*, 50(4):3171-3191
10. L Gentet, M Avermann, F Matyas, JF Staiger, and CCH Petersen (2010) *Neuron*, 65:422-435

Reconstruction of network connectivity in the irregular firing regime

Dmytro Grytskyy, Markus Diesmann^{1,2}, Moritz Helias¹

¹Research Center Jülich, INM-6 (Computational and System Neuroscience), Wilhelm-Johnen-Straße, 52425 Jülich, Germany;

²Medical Faculty, RWTH Aachen University

The question how to reconstruct the synaptic connectivity from the measurement of multi-unit neuronal activity has been studied since more than two decades, pioneered by the work of Aertsen and colleagues[1]. Since then a number of different approaches have been taken. In many works, correlated activity per se is considered as a measure of functional connectivity [2]. Other methods apply information theoretic measures, like Shannon entropy [3,4]. For networks subject to the repeated presentation of an external stimulus, Nykamp [5,6] developed a stochastic framework for time-binned spike trains that allows to distinguish between direct connections and common input. Applying the framework of phase oscillators, Timme [7,8] investigated networks exhibiting regular spiking due to external stimulation and obtained exact expressions for the connectivities from the perturbation of inter-spike-intervals. The linear approximation of the dynamic response of spiking model neurons provides accurate expressions for the cross covariances [9,10,11] and has recently been applied to reconstruct sparse network connectivities [12]. Within this framework, here we propose a method valid in the asynchronous irregular regime that enables the reconstruction of arbitrary synaptic connectivities from averaged rates and covariances measured in absence of external stimuli. Moreover, the method enables us to determine the shape of the neuronal response kernel. It requires the covariance matrix between spike trains in the Fourier domain, known as the cross-spectrum. The knowledge of the cross-spectrum at two distinct frequencies is sufficient to uniquely determine the connectivity matrix from a decomposition of the covariance matrix into symmetric and antisymmetric quantities. The neuronal response kernel can in addition be obtained for every frequency at which the cross-spectrum is given. The measurement at only one frequency, however, does generally not uniquely determine the connectivity, but strongly constrains possible solutions. This set of solutions corresponds to different choices of the matrix of eigenvectors of the covariance matrix.

Partially supported by the Helmholtz Alliance on Systems Biology, the Helmholtz Association in the Portfolio theme "Supercomputing and Modeling for the Human Brain", the Jülich Aachen Research Alliance (JARA), the Next-Generation Supercomputer Project of MEXT, and EU Grant 269921 (BrainScaleS).

1. Aertsen AMHJ, Gerstein GL, Habib MK, Palm G (1989) *J Neurophysiol* 61(5): 900-917
2. Stevenson IH, Rebesco JM, Miller LE, Kording KP (2008) *Curr Opin Neurobiol* 18(6): 582-588
3. Singh A, Lesica, NA (2010) *PLoS Comput Biol* 6(12): e1001035
4. Ito SY, Hansen ME, Heiland R, Lumsdaine A, Litke, AM, Beggs J (2011) *PLoS One* 6(11): e27431
5. Nykamp DQ (2009) *J Math Biol* 59(2): 147-173

6. Nykamp DQ (2005) SIAM J. Appl. Math. 65(6): 2005-2032
7. Van Bussel F, Kriener B, Timme M (2011) Front. Comput. Neurosci. 5: 3
8. Timme M (2007) Phys Rev Lett 98(22): 224101
9. Pernice V, Staude B, Cardanobile S, Rotter S (2012) Recurrent interactions in spiking networks with arbitrary topology. Phys Rev E 85: 031916
10. Trousdale J, Hu Y, Shea-Brown E, Josic K (2012) PLoS Comput Biol 8(3): e1002408.
11. Tetzlaff T, Helias M, Einevoll GT, Diesmann M (2012) PLoS Comp Biol 8(8):e1002596
12. Pernice V, Rotter S (2012). Front. Comput. Neurosci. Conference Abstract: Bernstein Conference 2012

Spike Pattern Detection by Frequent Itemset Mining

Emiliano Torre, Michael Denker¹, Christian Borgelt², David Picado², George Gerstein³,
Sonja Gruen^{1,4}

¹Institute of Neuroscience and Medicine, Computational and Systems Neuroscience, Forschungszentrum Juelich, Germany

²European Centre for Soft Computing, Calle Gonzalo Gutiérrez Quirós s/n, 33600 Mieres, Asturias, Spain

³Dept. of Neuroscience, University of Pennsylvania, Philadelphia PA 19104, USA

⁴Theoretical Systems Neurobiology, RWTH Aachen Univ, Aachen, Germany

Information processing in the cortex was suggested to be organized in cell assemblies (Hebb, 1949), i.e. groups of correlated neurons (cell assemblies) forming building blocks of information processing. Modern massively parallel extracellular recordings (Buzsaki 2004; see Symposium 24) make such network organization increasingly accessible. However, the analysis of such massively parallel spike trains (MPSTs) for the presence of active assemblies cannot be achieved by straightforward extension of existing methods (e.g. the Unitary Events (UE) analysis, Grün et al, 2002; Grün, 2009), since the evaluation of individual spike patterns would lead to combinatorial explosion. In addition, testing the significance of all patterns leads to a multiple testing problem, with the consequence of false positives.

On the other hand, approaching such data by only pairwise analysis with subsequent clustering led to the finding of distinct clusters of mutually correlated neurons (Berger et al, 2007). However, by this approach it is not possible to conclude on higher-order correlated groups of neurons.

Therefore we make here use of frequent itemset mining (FIM; Goethals, 2010) to efficiently count coincident spike patterns in MPSTs (Borgelt et al, in prep). This approach accretes more and more neurons thereby building an efficient search tree that avoids redundant searches, in contrast to the accretion algorithm by Gerstein et al (1978). By defining a minimum occurrence count (support) frequent patterns are detected. Further, we consider only "closed patterns", i.e. patterns that cannot be trivially explained by the occurrences of supersets containing them. The number of patterns considered by this procedure is considerably lower -though generally still large- than all possible combinations of patterns for N neurons (2^N for $N=100$). The multiple testing problem is further downsized by pooling closed frequent patterns into groups of same complexity (number of spikes in the pattern) and number of occurrences ("pattern spectrum", Gerstein et al, 2012). The significance of each entry in the spectrum is assessed through surrogates obtained by spike dithering (Gerstein, 2004). Only patterns corresponding to significant entries are considered and further evaluated for overlapping patterns. We calibrate the algorithm on simulated spike trains containing assemblies of synchronous spiking neurons (SIP correlations, Kuhn et al, 2003). Finally, we illustrate the application to massively parallel spike trains from monkey motor cortex (see also Poster by Zehl et al.), and compare our findings to results obtained by pairwise (Berger et al, 2007) and UE (Grün et al, 2002) analysis.

References:

- Berger, Warren, Normann, Arieli, Grün (2007) *Neurocomputing* 70, 2112-2116,
- Buzsaki (2004) *Nat Neurosci* 7(5):446-51
- Gerstein, Perkel, Subramanian (1978) *Brain Research* 140: 43 – 62
- Gerstein GL (2004) *Acta Neurobiol Exp (Wars)* 64(2):203-7.
- Grün, Diesmann, Aertsen (2002) *Neural Computation*, 14(1), 81-119
- Grün (2009) *Journal of Neurophysiology*, 101, 1126-1140
- Goethals (2010) *Springer US*, 321-338

Hebb (1949) New York: Wiley & Sons

Kuhn, Aertsen, Rotter (2003) *Neural Comput* 15(1): 67-101

Simulation of a multi-electrode array neurochip experiment with clonazepam

Kerstin Lenk, Olaf H.-U. Schroeder², Barbara Priwitzer¹

¹Lausitz University of Applied Sciences, Faculty of engineering and computer science, Großhainer Str. 57, 01968 Senftenberg, Germany

²NeuroProof GmbH, Friedrich-Barnewitz-Str. 4, 18119 Rostock, Germany

Multi-electrode array (MEA) neurochips are used to examine effects and toxicity of (potential) neuroactive compounds. The substance clonazepam is used in treatment of epilepsy. In an in vitro experiment approximately 500,000 cells of the frontal cortex of embryonic mice are cultivated on a MEA neurochip. Circa 10,000 neurons and 90,000 glia cells of the total amount survive. The object was to simulate these experimental data when clonazepam was added to the neurons.

We developed a pulsing neuronal model following the Glauber dynamics. Our model INEX (inhibitory-excitatory) is a cellular automaton whose cells represent neurons with two possible states: ON or OFF. The binary model should show several characteristics: Firstly, neurons are active without external input or stimulus as observed in experiments. Secondly, noise is observed. Last, bursts as a characteristic phenomenon of frontal cortex neuronal network cultures shall be generated. In order to simulate these properties we assume that the spikes obey an inhomogeneous Poisson distribution. The inhomogeneity of the neuronal activity is realized by inhibitory or excitatory synapses of varying strength. The corresponding parameters are called weights. Spike time history is added, i.e. the probability of spike occurring increases following a spike in the previous time slice.

We used a sparsely connected network with 10,000 neurons, i.e. 8,000 excitatory neurons and 2,000 inhibitory neurons following Dale's principle. Each of the 10,000 neurons is connected to approximately 1,000 other neurons. To simulate the addition of an inhibitory substance, like clonazepam, to the neuronal network, we reduced the excitatory weights.

From the generated 10,000 spike trains 20 were chosen randomly and compared to 20 randomly chosen MEA neurochip recordings of frontal cortex tissue of embryonic mice after 28 days in vitro. For the comparison spike and burst describing features were calculated. These features were displayed in concentration-response curves which were compared to concentration-response curves of MEA experiments.

The results of the simulation show, that spike and burst rate of the INEX model and of MEA experiments correspond which is also demonstrated in the concentration-response curves. Therefore, the INEX model shows potential to simulate data as observed in experiments with MEA neurochips.

Neuronal variability vs. precise stimulus discrimination in an olfaction-inspired network: A neuromorphic case study

Michael Schmuker, Thomas Pfeil³, Martin Paul Nawrot^{1,2}

¹Neuroinformatics & Theoretical Neuroscience, Dept. of Biology Chemistry Pharmacy, Freie Universität Berlin, Germany

²Bernstein Center for Computational Neuroscience Berlin, Germany

³Electronic Vision(s), Kirchhoff Institute for Physics, Universität Heidelberg, Germany

Insects need to associate stimuli with the availability of food for efficient foraging. Olfactory cues play a vital role in this task, and the olfactory system is likely well adapted to encode stimuli in a way that enables downstream circuits to easily learn to discriminate between different cues. It has been shown that a firing-rate based olfaction-inspired network enhanced stimulus discrimination in a supervised learning framework (Schmuker & Schneider, 2007). In the same study, the practical applicability of this network to the classification of multivariate data has been demonstrated, a common task in data analysis and machine learning.

The motivation of the present work was to implement this network on a neuromorphic hardware system that supports high-speed emulation of spiking neuronal networks (Schemmel et al., 2006). This system combines analog microelectronic circuits mimicking the behavior of integrate-and-fire neuron models with a digital circuitry controlling network connectivity and synaptic strength. Neurons on this system run with a speedup factor of 10^4 compared to biological real-time, in other words, one second of neuromorphic computation corresponds to 10,000 seconds of biological time, which qualifies this device for high-speed computation with spiking neurons.

Our goal was to implement a network for classification of multivariate data on the hardware system. To this end, we designed a two-layer network. The first layer provides decorrelation of input channels through lateral inhibition. The second layer performs association to data classes in a winner-take-all fashion on the basis of the work of Soltani and Wang (2010).

We demonstrate how our model combines several functional principles of sensory computation in animals, that is, parallel processing of multiple input dimensions, their decorrelation through lateral inhibition, and the transformation from a dense representation in a low-dimensional input space to a sparse representation in a high dimensional neural space in order to achieve accurate stimulus classification even for nonlinear problems. Our implementation performed at level with standard machine learning techniques on a set of benchmark stimuli. However, discrimination of stimulus classes with partial overlap (that is, high similarity) was severely affected by the heterogeneity of neuronal transfer functions caused by the inevitable physical variability of analog electronic circuits in the hardware system. We restored the network performance using a combination of global and network-specific calibration steps. Our results indicate that reliable learning of fine discrimination between stimulus classes requires either precisely tuned neurons with little variance or network mechanisms that compensate for individual neuronal variation. Our work serves as a proof of principle for the successful implementation of a functional neural network on a neuromorphic hardware system that can readily be applied to real-world problems.

This work was funded by DFG (MS, SCHM2474/1-1, SPP 1392), BMBF (MS and MN, 01GQ1001D, Bernstein Center for Computational Neuroscience Berlin) and EU FP7 (TP, 243914, Brain-i-Nets).

References

Schmuker M & Schneider G (2007). Processing and classification of chemical data inspired by insect olfaction. *PNAS* 104:20285–20289.

Schemmel J, Gruebl A, Meier K & Mueller E (2006). Implementing Synaptic Plasticity in a VLSI Spiking Neural Network Model. In *Proc. IJCNN 2006*, p. 1-6. IEEE press.

Soltani A & Wang X-J (2010). Synaptic computation underlying probabilistic inference. *Nat Neurosci.* 13:112–119.

The Extreme Learning Machine as a model to study pattern discrimination in insect brains

Niklas Flindt, Amir Madany Mamlouk², Michael Schmuker³

¹Institute for Neuro- and Bioinformatics, University of Lübeck, Germany

²Neuroinformatics & Theoretical Neuroscience, Dept. of Biology Chemistry Pharmacy, Freie Universität Berlin, Germany

³Bernstein Center for Computational Neuroscience Berlin, Germany

The Extreme Learning Machine (ELM) is an approach for machine learning based on an artificial neural network with one hidden layer (Huang et al., 2006). In the ELM, weights and biases to the hidden layer are initialized randomly and not modified afterwards. During training, the output weights are then derived using a least-squares approach, which makes ELM training extremely fast compared to backpropagation algorithms, while delivering comparable performance.

The concept of the ELM hidden layer – providing a large number of random transforms of the input from which a mapping to the correct output is derived – shares a certain similarity to the concept of the olfactory pathway in the insect brain. A characteristic feature of this system is the huge fan-out of connections from the primary relay station, the antennal lobe, to the multimodal integration center, the mushroom body (MB). For example, in *Drosophila*, information from about 50 input channels fans out to about 2500 mushroom body neurons. Those connections are thought to be made randomly, and it has been shown that random connectivity maximizes the coding capacity of the system (Jortner et al., 2007). The difference to the ELM is that each neuron in the MB receives input from random 50 % of input neurons, while the ELM has all-to-all connectivity from the input to the hidden layer.

In this study, our aim was to use the ELM as a model to analyze pattern discrimination in a fan-out architecture like found in the insect brain. To this end, we analyzed two aspects of the olfactory pathway in the MB. First, we checked whether degrading the connectivity between input and hidden layer to 50 % as found in the MB affected classification performance. Second, as odors in the MB are thought to be represented by single input spikes locked mainly to odor onset, continuous value coding with firing rates becomes unlikely. We therefore changed the representation of the features to discrete values in $\{-1,0,1\}$. We found that neither degrading connectivity to 50 % nor discretization of features had a negative impact on the performance of the ELM.

Our results suggest that a fan-out structure with random connectivity as found in the insect olfactory system is capable of learning complex data spaces with accurate classification comparable to state-of-the-art machine learning algorithms.

This work was funded by DFG (SCHM2474/1-1 to MS) and BMBF (01GQ1001D to MS).

References:

- Huang G-B, Zhu Q-Y & Siew C-K (2006). Extreme learning machine: Theory and applications. *Neurocomputing* 70:489-501.
- Jortner RA, Farivar SS & Laurent G (2007). A simple connectivity scheme for sparse coding in an olfactory system. *J Neurosci* 27:1659-1669.

Input-dependent decorrelation of neuronal activity in barrel cortex

Birgit Kriener, Gaute T. Einevoll¹

¹Norwegian University of Life Sciences (UMB), Institute of Mathematical Sciences and Technology (IMT), PO Box 5003, 1432 Aas, Norway

The barrel cortex of rats and mice is a highly topographically organized cortical structure with each barrel corresponding to exactly one individual whisker. Recently, it became possible to record membrane potentials of neurons in a barrel in awake behaving animals and correlate these measurements with the whisker movements and spiking activity [1,2,3]. If the animal sits quiet, membrane potentials show slow oscillations (~ 1-5 Hz) and high pairwise correlations, while during whisking these oscillations get reduced and membrane potential correlations decrease [3].

In particular, during quiet wakefulness spiking of excitatory neurons is hardly correlated and driven by individual depolarizing inputs, whereas the spiking of inhibitory cells is clearly correlated and coincides with the depolarized phase of the membrane oscillation. In response to sensory input it appears that it is predominantly the spike correlations between excitatory and inhibitory neurons that get reduced, while excitatory-excitatory spike correlations stay low and unaffected [4]. This decorrelation of barrel activity is believed to enhance the signal processing and decoding of sensory input [5]. In [4,5] both simplified rate models as well as spiking neuron network simulations were presented that explain the decorrelation in response to sensory input by feed-forward inhibition and spike threshold non-linearities.

Here, we study recurrent spiking neuron networks that comply with the measured connectivity, neuron parameters, and synaptic weight statistics for layer 2/3 and 4 of barrel C2 of barrel cortex [6,7], and analyze under which circumstances these networks produce the observed membrane potential and spike correlations in different input regimes. From a theoretical point of view it is noteworthy that the barrel cortex networks are much denser and more strongly connected than commonly assumed e.g. in the theory of balanced random networks [8,9], and that rates of individual neuron types are very disparate, with excitatory neurons firing at much smaller rates (~ 1/s) than inhibitory neurons (~10/s) [3].

We find that spiking neuron network models that incorporate the observed connectivity statistics, weight distribution and neuron parameters generically produce firing rates that are in line with these experimentally observed rates, and that firing rates can be self-consistently predicted by a meanfield model. Moreover, we find that an increase of input specifically to the layer 2/3 inhibitory population leads to a decorrelation of the whole layer 2/3 network, as well as individual membrane potentials and spike trains. We present a mean-field model that explains this input-dependent decorrelation.

We gratefully acknowledge funding by the eScience program of the Research Council of Norway under grant 178892/V30 (eNeuro).

1. Crochet, S., Petersen C.C.H. (2006) Correlating whisker behavior with membrane potential in barrel cortex of awake mice. *Nature Neuroscience* 9(5): 608-610
2. Poulet J.F.A., Petersen C.C.H. (2008) Internal brain state regulates membrane potential synchrony in barrel cortex of behaving mice. *Nature* 454:881-887

3. Gentet, L.J., Avermann, M., Matyas, F., Staiger, J.F., Petersen, C.C.H. (2010) Membrane potential dynamics of GABAergic neurons in the barrel cortex of behaving mice. *Neuron* 65:422-435
4. Middleton, J.W., Omar, C., Doiron, B., Simons, D.J. (2012) Neural correlation is stimulus modulated by feedforward inhibition. *J Neurosci* 32(2):506-518
5. Ly, C., Middleton, J.W., Doiron, B. (2012) Cellular and circuit mechanisms maintain low spike co-variability and enhance population coding in somatosensory cortex. *Frontiers Comput Neurosci* 6:7
6. Lefort, S., Tamm, C., Floyd Sarria, J.C., Petersen, C.C.H. (2009) The excitatory neuronal network of the C2 barrel column in mouse primary somatosensory cortex. *Neuron* 61:301-316
7. Avermann, M., Tamm, C., Mateo, C., Gerstner, W., Petersen, C.C.H. (2012) Microcircuits of excitatory and inhibitory neurons in layer 2/3 of mouse barrel cortex. *J Neurophysiol* jn.00917.2011
8. van Vreeswijk, C., Sompolinsky, H. (1996) Chaos in neuronal networks with balanced excitatory and inhibitory activity. *Science* 274(5293):1724-1726
9. Brunel, N. (2000) Dynamics of sparsely connected networks of excitatory and inhibitory spiking neurons. *J Comput Neurosci* 8:183-208

Reliability of algorithms for automatized detection of neuronal activity *in vitro*

Franz Carlsen, Knut Kirmse¹, Ernst Günter Schukat-Talamazzini², Knut Holthoff¹

¹Hans-Berger-Klinik für Neurologie, Universitätsklinikum Jena, Erlanger Allee 101, 07747 Jena, Germany

²Institut für Informatik, Fakultät für Mathematik und Informatik, Friedrich-Schiller-Universität Jena, Ernst-Abbe-Platz 3, 07737 Jena, Germany

Large-scale calcium imaging has become a widely-used technique for simultaneous recording of neuronal activity in neuronal networks. Because of the extensive amount of data an automatized detection of individual calcium transients in a reasonable time frame is essential. Although several approaches have been developed to achieve this mission, a quantification of the reliability of different algorithms for different signal conditions is still missing. Here we provide an objective testbed including an evaluation data set with different signal-to-noise ratio settings as well as with sparse and high activity regimes. We systematically compared the performance between a simple threshold algorithm, a template matching approach, and a combination of principal component analysis and support vector machine. The reliability of these algorithms was quantified on raw data, baseline corrected data and filtered data using F1 score as quality criterion. The support vector machine outperformed other approaches on raw data and baseline corrected data for all levels of activity and signal-to-noise ratios. Only for filtered data the threshold algorithm turned out to be the most reliable. We conclude that for all tested algorithms the support vector machine provides the most accurate and reliable results, at the expense of the acquisition of a sufficient amount of training data.

Microscopic recruitment of network spikes in recurrent networks with synaptic short-term plasticity

Christoph Bauermeister, Gustavo Deco², Jochen Braun¹

¹Otto-von-Guericke Universität Magdeburg, Institut für Biologie, Abteilung Kognitionsbiologie, Leipziger Straße 44 / Haus 91, 39120 Magdeburg, Germany

²Universitat Pompeu Fabra, Barcelona, Spain

Recurrent networks with synaptic short-term plasticity show intermittent states of high activity in which virtually all neurons fire simultaneously ("network spikes"). A subpopulation of neurons with low to intermediate activity is instrumental in triggering such network spikes (Tsodyks, Uziel, Markram, 2000, *J Neurosci* 20 RC50(1-5)), in that they fire reliably before the network spike and in that their suppression eliminates most network spikes. Here we investigate the rank order of spikes among these 'early firing' neurons in simulated networks of excitatory and inhibitory neurons. Our simulations show that, given sparse random connectivity, this rank order is highly preserved and typically divided into several distinct cohorts of 'early firing' neurons, which are recruited in quasi-deterministic order. In each case, activity propagates to the next cohort only after the last member of the preceding cohort has fired. These quasi-deterministic "microscopic recruitment paths" match experimental observations from mature cortical neuron cultures (Shahaf et al., 2008, *PloS Computational Biology*, 4(11)e1000228). We surmise that this "order-based representation" reflects the variability of connectivity and, furthermore, that it tightly constrains the effective connectivity of cortical neuron cultures.

The connectome of the spinal cord of the rat

Oliver Schmitt, Peter Eipert¹, Ann-Kristin Klünker¹, Richard Kettlitz¹, Pauline Morawska¹, Andreas Wree¹

¹University Rostock, Anatomy, Gertrudenstr. 9, 18055 Rostock, Germany

The connectome of the spinal cord of the rat comprises all known intrinsic and extrinsic connections of the left and right side of each of the 34 spinal segments (8 cervical, 13 thoracic, 6 lumbal, 4 sacral, 3 coccygeal). In a meta-analysis of 786 peer-reviewed publications which use tract-tracing techniques, afferent and efferent connections of the adult rat spinal cord have been collected in a neuroontological framework of the rat nervous system (Schmitt and Eipert, 2012).

1537 spinal regions are connected by 20100 intrinsic connections and possess 26994 afferents and 34676 efferents. Regions that have afferents or efferents to or from the spinal cord have been filtered at a level of subdivision below the principal parts of the cranial part of the CNS (midbrain, rhombencephalon, basal forebrain, diencephalon telencephalon) yield 38 subregions interconnected by 739 projections. This coarse spinal connectome (line density: 52%, average degree: 39) has a small-world property and is scale-free with regard to the power-law. The midbrain, metencephalon, myelencephalon, hypothalamus, thalamus and motoric cortical regions have major interconnections to and/or from the spinal cord. Most afferents to the spinal cord originate from the reticular system, cerebellum and periaqueductal gray. 559 contralateral connections exist. The density of contralateral connections is larger with regard to spinal cord segments than to non-spinal regions. All major ascending and descending pathways can be reconstructed using a pathway approach in neuroVIISAS. In conclusion, the spinal connectome is integrated in the complete connectome of the rat and is available now for connectome based network design. These networks may represent regions of the peripheral nervous system as well as central targets. Hence, it is feasible to define spiking populations in these realistic connectome based networks to perform more realistic simulations.

Reference

Schmitt O, Eipert P (2012) neuroVIISAS: approaching multiscale simulation of the rat connectome. *Neuroinformatics* 10: 243-267.

Winner-take-all circuits exhibit key hallmarks of binocular rivalry

Svenja Marx, Gina Gruenhage^{1,2}, Daniel Walper¹, Ueli Rutishauser^{3,4}, Wolfgang Einhäuser¹

¹Neurophysics, Philipps-University, Marburg, Germany

²Bernstein Center for Computational Neuroscience, Berlin, Germany

³Neurosurgery, Cedars-Sinai Medical Center, Los Angeles, CA, USA

⁴Division of Biology, California Institute of Technology, Pasadena, CA, USA

Perception is inherently ambiguous. This ambiguity is frequently modeled by rivalry, a situation, in which a constant stimulus evokes distinct perceptual interpretations that alternate over time. Specifically, binocular rivalry occurs when the two eyes are presented with sufficiently distinct stimuli. Any successful model of rivalry needs to describe at least a series of phenomena which have been firmly established in numerous experiments. First, dominance durations, the times in which one of the possible percepts is perceived, follow a heavy-tailed distribution. Second, the effects of changes in stimulus strength (e.g., contrast of one or both stimuli) on dominance durations follow a well-defined pattern, known as modified Levelt's propositions (Levelt 1966). Third, if the stimulus is removed periodically for a sufficient duration ("blanking"), one percept stabilizes, while destabilization occurs for short blank durations.

Several models have been proposed for rivalry, which to varying degrees replicate these phenomena. These models usually rely on mutual inhibition, adaptation and noise and aim at explaining specific aspects of rivalry. Here, we present an alternative and novel approach to obtain a more generic model of rivalry. We employ a winner-take-all network consisting of three areas of two excitatory and one inhibitory unit each. This network exhibits the three aforementioned hallmarks of rivalry and also makes new testable predictions, which we verify experimentally. Being a generic model of neuronal circuitry rather than a model tailored to explain specific aspects of rivalry, our model extends well beyond the realm of rivalry as such. The model provides a natural link of rivalry to other forms of perceptual ambiguity and to other competitive processes, such as attention and decision-making.

This makes our approach not only a powerful and biologically plausible model for rivalry, but also a promising candidate to unify various perceptual and cognitive processes in a framework of generic neocortical microcircuits.

Toward a spiking multi-area network model of macaque visual cortex

Maximilian Schmidt, Sacha van Albada¹, Rembrandt Bakker^{1,2}, Markus Diesmann^{1,3,4}

¹Forschungszentrum Jülich, Institute of Neuroscience and Medicine, INM-6, 52425 Jülich, Germany

²Donders Institute for Brain, Cognition and Behavior, Radboud University Nijmegen, Netherlands

³Faculty of Medicine, RWTH Aachen University

⁴RIKEN Brain Science Institute, Wako-Shi, Japan

The investigation of large neural network models incorporating several spatial and/or temporal scales has been limited to date by the available computational resources. The availability of JUQUEEN and of the K supercomputer in Kobe, Japan, and recent progress in the simulation technology of NEST ^[1] have partly lifted this barrier. The multi-scale neural network model of the macaque visual cortex presented here will make use of these facilities to derive aspects of cortical dynamics that were hitherto inaccessible to computational exploration.

The model extends a recent microcircuit model of primary visual cortex ^[2] to 32 visual cortical areas of the macaque, taking into account their layered structure. By expanding the areas to realistic sizes we will account for a large majority of the synapses onto each neuron, in contrast to the local microcircuit model which only accounts for about half of the synapses.

We compile the connectivity map from multiple datasets including data from electro-physiological measurements ^[3], anatomical studies collected in CoCoMac ^[4] and quantitative tract tracing ^[5]. These extensive but incomplete data are complemented with estimates based on empirical connectivity rules, such as a decrease of connection probability with distance, and a dependence of layer specificity on the different architectures of the areas.

In modeling the single-neuron dynamics, only excitatory and inhibitory neuron types are distinguished, and their morphology is disregarded. These simplifications enable us to study the influence of connectivity itself on cortical dynamics, independent of detailed single-neuron properties. The ability of the structure to account for known aspects of cortical dynamics will be tested using layer- and area-specific firing rates, regularity and synchrony of spiking, and frequency spectra.

Since cortical function only arises through the interaction of multiple areas, the extension to multi-area networks is an important step toward modeling functional circuits. The model also has a prominent integrative component, bringing together data from different sources into a unified framework. We present the workflow from the data to the consistent connectivity scheme in which future experimental data can be incrementally incorporated without changes to the framework.

In order to study the influence of structural properties of the cortex, we start with a down-scaled version of the model, where the areas are described by a microcircuit representing the neurons under 1 mm² of cortical surface. We show that this reduced model can be simulated on a modern high-performance cluster and present preliminary results on the network activity.

Acknowledgements: This work was partly supported by EU FP7 Grant 269921 (BrainScaleS), the Helmholtz Alliance on Systems Biology, the Helmholtz Association in the Portfolio theme "Supercomputing and Modeling for the Human Brain", the Jülich Aachen Research Alliance (JARA), the VSR computation time grant JINB33 on the JUGENE supercomputer in Jülich, and the Next-Generation Supercomputer Project of MEXT. All network simulations carried out with NEST (<http://www.nest-initiative.org>).

References:

- [1] Gewaltig M-O, Diesmann M (2007). NEST (Neural Simulation Tool). Scholarpedia, 2, 1430
- [2] Potjans T, Diesmann M (2012). The cell-type specific cortical microcircuit: relating structure and activity in a full-scale spiking network model. ArXiv:1106.5678 [q-bio.NC]
- [3] Binzegger T, Douglas RJ, Martin KAC (2004) A quantitative map of the circuit of cat primary visual cortex. *J Neurosci* 39 (24), 8441–8453
- [4] Stephan KE & Kamper L & Bozkurt A & Burns GAPC, Young MP & Kötter R (2001). Advanced database methodology for the collation of connectivity data on the macaque brain (CoCoMac). *Phil Trans R Soc Lond B*, 356, 1159-1186.
- [5] Markov NT, Misery P, Falchier A, Lamy C, Vezoli J et al (2011) Weight consistency specifies regularities of macaque cortical networks. *Cerebral Cortex*, 21, 1254-1272.

Action potential shape and spike encoding properties mature in parallel in cultured hippocampal neurons

Elinor Lazarov, Michael Gutnick², Fred Wolf¹, Andreas Neef¹

¹Max Planck Institute for Dynamics and Self-Organization, Goettingen, Germany

²Koret School of Veterinary Medicine, The Hebrew University of Jerusalem, Rehovot, Israel

Action potential (AP) generation begins with the activation of Na⁺ channels in the proximal axon, in the axon initial segment (AIS). The distal end of the AIS is most excitable, as it is further away from the large capacitive sink of the somatic membrane; the Na⁺ channels in the AIS are reported to have more depolarized voltage dependence. The Na⁺ currents that flow during the first hundred microseconds in the proximal axon shape the onset of the somatic AP waveform, while the second phase of the somatic AP upstroke is shaped by local, somatic Na⁺ currents.

Na⁺ channel voltage dependence and activation kinetics in the AIS control the initial shape of the AP in the AIS, as well as the exact timing of the AP in relation to the input current waveform. The latter can be characterized by the shape of the spike-triggered average of the input (STA). To which degree the early AP shape at the soma, tens of microseconds from the AIS, is also related to STA, is currently debated; multi-compartment models do not provide unambiguous answers, as the actual values of several key parameters, e.g. somatic and axonal Na⁺ channel density and voltage dependence are controversially discussed in the community.

We studied the maturation of AIS function in hippocampal neurons in culture, as revealed by developmental changes in the AP waveform, and the relationship of these changes to maturation of neuronal encoding properties, as revealed by the STA. AP waveform was characterized by parameters determined from the phase plot (dV/dt vs V): V_{thresh} , onset rapidness, peak rate of rise (maximum dV/dt) and V_{peak} . To characterize the transfer function of the neurons, they were stimulated with a fluctuating current (Ornstein-Uhlenbeck process) with correlation time of 5 ms. The mean current was chosen to achieve an average V_{mem} of -60 mV, the variance was chosen to drive APs at 1 to 3 Hz.

The earliest APs were recorded at 6 days *in-vitro* (DIV), shortly after AIS formation can be detected by molecular markers, and AP maturation was monitored over the subsequent 6 weeks. We found that all the measures of AP shape changed quickly within the first week of AP firing: V_{thresh} dropped by 4 mV, the other 3 measures increased. After 20 DIV the shape of APs was largely stable. Passive properties of the membrane (t_m , R_m and C_m) changed as well during development. The maturation of cell properties and AP properties was paralleled by maturation of neuronal encoding properties. The STA became more narrow and the slope of the dynamic gain curve at high frequencies decreased. The dynamic gain curves displayed high frequency power-law tails with slopes between -0.35 (<10 DIV neurons) and -0.15 (mature neurons). Dynamic gain curves of single compartment models can also show such power-law tails, however conductance based models display slopes of -1, while leaky integrate and fire models produce power-law tails of -0.5 for colored noise and no fall-off for white noise input.

ANOVA test showed that the membrane time constant is a strong predictor of STA width, as expected in the regime of fast input fluctuations ($t_{\text{corr}} \ll t_m$). The STA width also showed a tendency of a negative correlation with onset rapidness. This relation would be expected from theory, if onset rapidness was a proxy for axonal Na⁺ channel voltage dependence.

Application of Network Theory to real living Cultures

Christian Claus Schmeltzer

¹HU Berlin, IRTG 1740, Newtonstr 15, 12489 Berlin, Germany

With a network-theoretical approach, we study the steady state firing rate of a network of leaky integrate and fire neurons, focussing on the impact of basic network statistics like the degree distribution and degree correlations on the collective dynamical behavior.

Desynchronizing effect of high-frequency stimulation in a generic cortical network model

Jens Christian Claussen, Markus Schütt¹

¹University Luebeck, INB, Ratzeburger Allee 160, 23562 Luebeck, Germany

Transcranial Electrical Stimulation (TCES) and Deep Brain Stimulation (DBS) are two different applications of electrical current to the brain used in different areas of medicine. Both have a similar frequency dependence of their efficiency, with the most marked effects around 100 Hz. We apply superthreshold electrical stimulation, specifically depolarizing DC current, interrupted at different frequencies, to a simple model of a population of cortical neurons which uses phenomenological descriptions of neurons by Izhikevich and synaptic connections on a similar level of sophistication. With this model, we are able to reproduce the optimal desynchronization around 100Hz, as well as to predict the full frequency dependence of the efficiency of desynchronization, and thereby to give a possible explanation for the action mechanism of TCES.

[1] Markus Schütt and Jens Christian Claussen, *Cognitive Neurodynamics* 6 (2012) 343-351

Poster Topic

T27: Techniques and Demonstrations

- T27-1A** Structural and quantitative MRI of the common marmoset monkey using a clinical 3T scanner
Gunther Helms, Enrique Garea-Rodriguez, Christina Schlumbohm, Jessica König, Peter Dechent, Eberhard Fuchs, Melanie Wilke
- T27-2A** A wireless and fully implantable recording system for ECoG signals
David Rotermund, Dmitriy Boll, Victor Gordillo-Gonzalez, Darren Gould, Thomas Hertzberg, Janpeter Höffmann, Sunita Mandon, Dagmar Peters-Drolshagen, Jonas Pistor, Marius Richter, Tim Schellenberg, Elena Tolstosheeva, Guido Widman, Christian E. Elger, Walter Lang, Steffen Paul, Martin Schneider, Klaus R. Pawelzik, Andreas K. Kreiter
- T27-3A** A high-resolution, photoactivated transgene expression method *in vivo* to study homeostatic effects of genetically altered neuronal activity
Aline Dubos, Alexandre Specht, Sidney Cambridge
- T27-4A** An Optogenetic approach to the auditory system of the Mongolian gerbil
Stefan Keplinger, Fred Koch, Stylianos Michalakis, Martin Biel, Benedikt Grothe, Lars Kunz
- T27-5A** Optical Imaging: A Comparison of Two Methods in Mice and Birds
Neethu Michael, Nina Keary, Uwe Mayer, Hans-Joachim Bischof, Siegrid Löwel
- T27-6A** Targeted-Esterase induced Dye loading (TED) assisted ER calcium imaging is improved with a new red-fluorescent esterase construct
Samira Samtleben, Caroline Fecher, Robert Blum
- T27-1B** Acquisition of multineuronal spike events from brain slices
Kai Gansel, Wolf Singer
- T27-2B** Automated analysis of spontaneous synaptic activity in whole cell current clamp recordings
Alexander Drakew, Urban Maier, Anja Tippmann, Michael Frotscher
- T27-3B** Response properties of the genetically-encoded optical H₂O₂ sensor HyPer
Jonathan Weller, Michael Müller
- T27-4B** Testing and Improvement of a Spike Sorting Algorithm
Christopher Doerr, Dirk Hoehl, Uwe Thomas, Thomas Schanze
- T27-5B** Data management for efficient and reproducible research
Andrey Sobolev, Aljoscha Leonhardt, Christian Kellner, Philipp L. Rautenberg, Andreas V. Herz, Thomas Wachtler

- T27-6B** Cell viability testing with a sponge alkaloid: Ageladine A indicates acidification during physiological stress and apoptosis
Ulf Bickmeyer, Kristin Tietje, Benedikt Hofbauer, Christine Fink, Thomas Roeder, Christian Wegener, Guido Schramm
- T27-7B** Single-Particle Tracking of Neuronal Surface Proteins in Brain Slices
Barbara Biermann, S. Sokoll, J. Klueva, M. Missler, M. Heine
- T27-1C** Calcium Imaging and Optical Manipulation of Vestibular Neurons in the Axolotl
Stephan Drenberger, Roberto Banchi, Christian Seebacher, Felix Felmy, Hans Straka, Lars Kunz
- T27-2C** Conditional photolabeling of individual neurons in transgenic mouse lines *in vivo*.
Manuel Peter, Brice Bathellier, Bruno Fontinha, Simon Rumpel
- T27-3C** BONCAT and GINCAT - Or how to tag newly synthesized proteins with a click
Anke Müller, Christine Freitag, Thilo Kähne, Daniela C. Dieterich
- T27-4C** Sufficient across-tip diffusion occurs with sharp microelectrodes filled with high ionic-strength solutions to alter membrane conductances within typical experimental durations
Jeffrey Bryan Thuma, Christoph Guschlbauer, Ansgar Büschges, Scott Llewellyn Hooper
- T27-5C** Analysis of infection efficacy, tropism, immunogenicity, and axonal transport of rAAV serotypes in the mouse brain
Dominik Florian Aschauer, Sebastian Kreuz, Simon Rumpel
- T27-1D** In vivo imaging of PKA activation in the striatum using an optical fiber bundle and biosensor.
Pierre Vincent, Marina Brito, Elvire Guiot, Liliana Castro, Jin Zhang, Danièle Paupardin-Tritsch
- T27-2D** Improving multi-photon imaging to study olfactory coding in insects
Georg Raiser, Marcel Wunram, Sabine Scheibe, C. Giovanni Galizia
- T27-3D** Systematic Individual Differences in Spatial Navigation - an Online Study
Caspar Mathias Goeke, Peter König, Klaus Gramann
- T27-4D** Brain tumor volume as a reliable predictor for overall glioblastoma patients survival – a epidemiological approach
Katharina Sofia Friedlein
- T27-5D** Pharmacological evaluation of the efficacy of Tricaine (MS-222) as an anesthetic agent for blocking sensory-motor responses in *Xenopus laevis*
Carlana Ramlochansingh, Francisco Branoner, Werner Graf, Hans Straka
- T27-6D** Self Motion from Optic Flow Monitored by Optical Mouse Chips
Hansjürgen Dahmen, Hanspeter A. Mallot

Structural and quantitative MRI of the common marmoset monkey using a clinical 3T scanner

Gunther Helms, Enrique Garea-Rodriguez^{2,3}, Christina Schlumbohm⁴, Jessica König³, Peter Dechent¹, Eberhard Fuchs^{2,4}, Melanie Wilke^{1,3}

¹Göttingen University Medical Centre, Dept. of Cognitive Neurology, Robert-Koch-Str. 40, 37075 Göttingen, Germany

²German Primate Center, Clinical Neurobiology Laboratory, Kellnerweg 4, 37077 Göttingen, Germany

³Center for Molecular Physiology of the Brain (CMPB), University of Göttingen
37075 Göttingen, Germany

⁴Encepharm GmbH, Hans-Adolf-Krebs-Weg 9, 37077 Göttingen, Germany

Purpose:

The common marmoset monkey is increasingly used as a model for neurodegenerative diseases. Using a 3T clinical MRI scanner, methods for structural and quantitative brain MRI were adapted from humans to marmosets.

Material and Methods:

Healthy adult marmosets were anesthetized and examined in supine position on a Siemens TiM TRIO using the 8-channel wrist coil. Examination time was 30 min with intramuscular injection and 3 hours with intubation anesthesia.

The trade-off between resolution and measurement time was explored for MRI with T1- and T2-weighting and gradient echo-based multi-parameter mapping of T1, T2*, and magnetization transfer (MT). The physiological parameters of a gadolinium contrast agent (Gadovist, 0.3 mmol/kg) were determined from consecutive measurements of $R1=1/T1$ in the straight sinus. Diffusion tensor imaging (DTI) was performed at 1 mm resolution along 64 directions; time-of-flight (TOF) angiography with 0.3 mm resolution.

Results:

A combined protocol of structural MRI (see Fig) and multi-parameter mapping with 0.4 mm isotropic resolution required 25 min, being compatible with injection anesthesia. Highly myelinated intracortical structures such as the V5 areas and the layer IV were delineated on T1- and MT-maps. Midbrain anatomy, including the substantia nigra, was best visualized on T2-w MRI. Visualization of such anatomical detail required 0.33 mm resolution and two averages to reduce noise. Thus, the 70 min protocol must be performed under inhalation anesthesia. Quantitative values of MT and T1 were similar to humans, but longer T2* indicated reduced iron content in the deep brain nuclei (not shown). Serial R1 measurements after Gadovist infusion (5 min intervals at 0.5 mm) yielded excretion half-times between 24 and 50 min, being shorter than in humans. TOF angiography showed the internal and external carotid arteries on maximum-intensity projections. The resolution limit was met at the finer branches, like the middle cerebral artery. DTI showed the major axonal tracts, like the pyramidal tract and the optic radiation, notwithstanding susceptibility-related distortions in the basal regions.

Conclusion:

The presented quantitative neuroimaging applications have been transferred from humans to marmosets using standard clinical MRI hardware only. Techniques can be combined to meet the needs of a specific translational study. In particular, rapid structural screening as 0.4 mm resolution can be performed under injection anesthesia, avoiding the adverse effects of inhalation anesthesia and permitting for routine scanning and frequent follow-up.

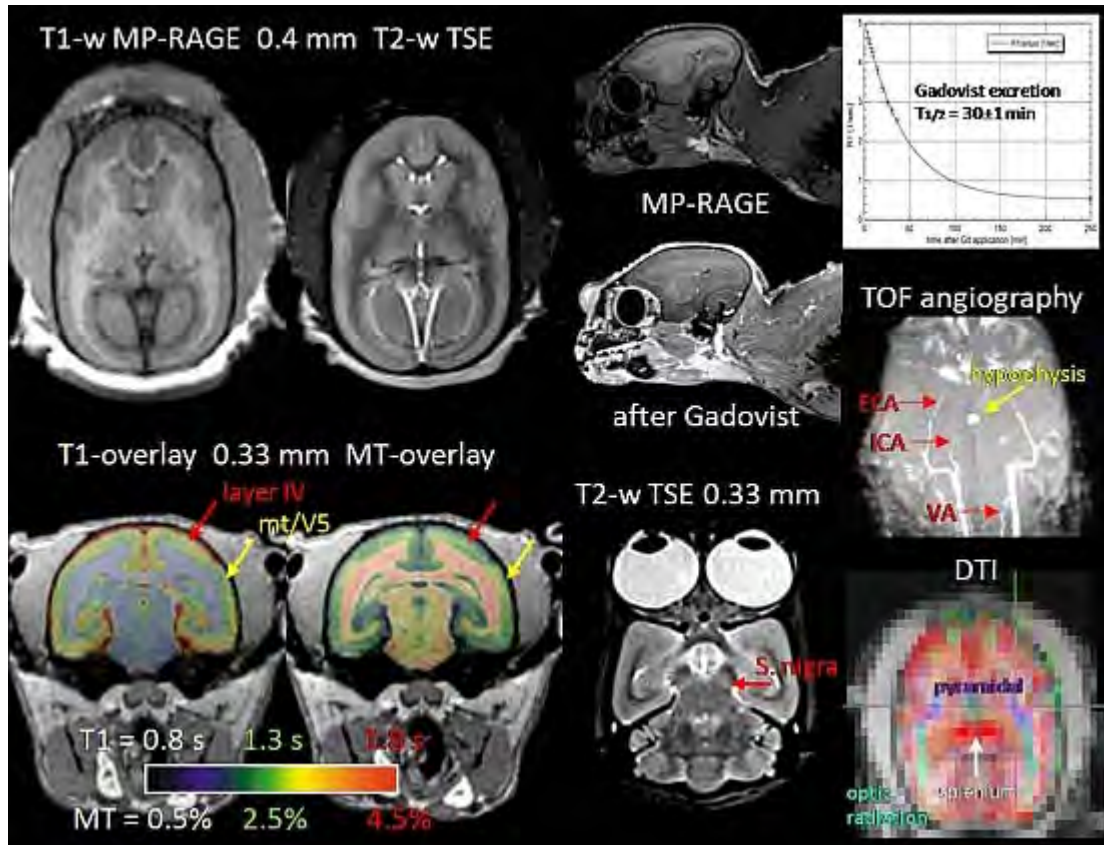

A wireless and fully implantable recording system for ECoG signals

David Rotermund, Dmitriy Boll², Victor Gordillo-Gonzalez³, Darren Gould², Thomas Hertzberg², Janpeter Höffmann^{4,5}, Sunita Mandon³, Dagmar Peters-Drolshagen⁴, Jonas Pistor⁴, Marius Richter⁶, Tim Schellenberg⁶, Elena Tolstosheeva², Guido Widman⁷, Christian E. Elger⁷, Walter Lang², Steffen Paul⁴, Martin Schneider⁶, Klaus R. Pawelzik¹, Andreas K. Kreiter³

¹ Institute for Theoretical Physics, University of Bremen, Germany

² Institute for Microsensors, actuators and systems (IMSAS), University of Bremen, Germany

³ Institute of Brain Research, University of Bremen, Germany

⁴ Institute of Electrodynamics and Microelectronics (ITEM), University of Bremen, Germany

⁵ Brain Products GmbH, Germany

⁶ RF & Microwave Engineering Laboratory, University of Bremen, Germany

⁷ Department of Epileptology, University of Bonn, Germany

Massively parallel, chronic measurements of neuronal activity over long periods of time are important for fundamental research as well as medical applications. Major requirements for such an electrophysiological recording system are medical safety and a large number of electrodes allowing recordings with high spatial and temporal resolution.

In order to address these requirements, we are developing a fully implantable, wireless recording system for electrocorticography (ECoG). Without any wired connection passing through the skull, we avoid any points of entry for infections and remove the risk of inflicting harm by pulling the cables. Our system approach is defined as follows: A thin foil carries the necessary electronics and a set of embedded electrodes interfacing the surface of the brain. These electrodes are electrically connected to an array of amplifiers and 16bit analog-digital-converters (ADCs). The acquired data is processed by an application-specific integrated circuit (ASIC). It prepares the data for efficient wireless data transmission using a RF-transceiver and custom antennas. A base station outside the body receives the data and delivers it via Ethernet to a software application. In addition, the system is wirelessly powered via an inductive link.

To implement this concept, a 10µm thick polyimide foil, providing an active area of 135mm² with 128 embedded gold electrodes, was fabricated in our clean room. The ASIC was designed in house for a 150nm standard CMOS process. It allows selecting relevant channels for recording, downsampling, reducing resolution, and power management for the analog frontend. We also designed and assembled the antennas for data transmission and coils for energy transmission through well conducting tissue. In addition, the base station including software and an extracranial prototype comprising the electronics were developed and build.

With measurements from macaque's visual area V1 using a chronically implanted foil with 128 electrodes, we successfully acquired ECoG data. Mapping the recording site's visual receptive fields revealed a high spatial and temporal resolution of the electrodes. Connecting the implanted array with the extracranial prototype, we demonstrated successful acquisition, processing, and transmission of data. Furthermore, we successfully tested the inductive energy link.

The remaining challenges in this project are to assemble all electronic components on a foldable flexible foil carrying the electrodes and to improve the system's lifetime by enhancing its protection against the environment inside the skull.

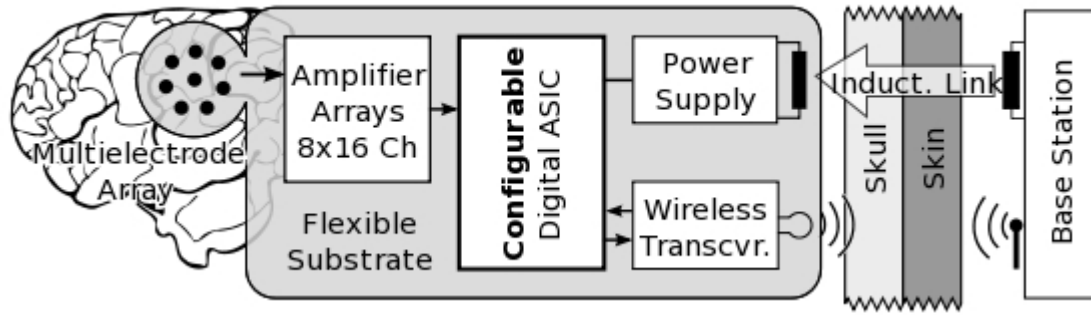

A high-resolution, photoactivated transgene expression method *in vivo* to study homeostatic effects of genetically altered neuronal activity

Aline Dubos, Alexandre Specht², Sidney Cambridge¹

¹University of Heidelberg, Department of Anatomy and Cell Biology, Im Neuenheimer Feld 307, 69120 Heidelberg, Germany

²Louis Pasteur University, Laboratoire de Conception et Application de Molécules Bioactives, UMR 7199, CNRS/UDS, Faculté de Pharmacie, 74 Route du Rhin, 67400 Illkirch, France.

The study of neuronal function is a challenge requiring tools that allow the manipulation of genes and signalling pathways with high temporal and spatial resolution. To this end, we are developing a new technique for high-resolution regulation of transgene expression *in vivo* by irradiation with light, called photoactivated gene expression. This technique is based on the inducible tetracycline (Tet) system and the reversible inhibition of the tetracycline analogue doxycycline by conjugation with a photolabile protection compound ("caging"). Upon irradiation with light, the conjugation between the caging compound and the doxycycline is photolysed, leading to the release of active doxycycline, which in turn binds to the Tet transcription factor and induces transcription of the transgene. Thus, this all-optical, non-invasive technique complements the optogenetic tools by providing high spatio-temporal control and specificity for transgene expression.

We successfully demonstrated 2-photon mediated photoactivated gene expression *in vitro* and now aim to apply this method to individual neurons in living mice. Pilot experiments showed after stereotactic injection of a caged red fluorophore that we could uncage it in mouse brains at depths of 400 μm using 2-photon mediated photolysis. This is one of the first demonstrations of uncaging in intact brains. Moreover, the cage on the fluorophore is the same as for the caged doxycycline and we previously found in other systems that uncaging of both compounds worked with similar efficiency. Therefore, we are currently establishing conditions for photoactivating caged doxycycline after virus-mediated transduction of the Tet system components into cortical and retinal neurons of wild-type mice.

Our next step will be the study of homeostatic mechanisms that regulate neuronal network activity by expression of the *Kir2.1* gene which silences neuronal activity cell-autonomously and comparison of irradiated cell(s) with the unirradiated, surrounding cells with normal expression pattern. Since the photoactivated neuron can be analyzed before, during, and after *Kir2.1* expression, the effects of transgene expression can then be directly correlated to network activity.

An Optogenetic approach to the auditory system of the Mongolian gerbil

Stefan Keplinger, Fred Koch², Stylianos Michalakis², Martin Biel², Benedikt Grothe³,
Lars Kunz¹

¹Ludwig Maximilians University Munich, Neurobiology, Dept. Biology II, Germany

²Dept. Pharmacy, Ludwig Maximilians University Munich, Germany

³Bernstein Center for Computational Neuroscience Munich, Germany

The Mongolian gerbil (*Meriones unguiculatus*) represents an apt model organism for human hearing due to its similar hearing range and ability to localise low frequency sound sources. However, electrophysiological recordings in auditory nuclei reach their limit in specificity when it comes to electrical stimulation within these nuclei heavily intermingled with massive fibre bundles passing through. In contrast, utilising optogenetic techniques would allow for specific control of electrical activity of neurones in individual auditory nuclei by light and would circumvent off-target responses from passing fibres where electrical stimulation lacks precision. However, by choosing the Mongolian gerbil as model we currently lack genetic tools already established in mouse or rat, which has so far hampered the use of optogenetics in this species.

To establish optogenetics in the Mongolian gerbil, we performed stereotactic injection of adeno-associated virus (AAV) into auditory nuclei of anaesthetised animals followed by an expression period of 2-3 weeks. Animals were sacrificed and brain slice preparations were performed. Whole-cell patch-clamp recordings from targeted auditory nuclei in acute brain slices were used to characterise kinetic parameters of the expressed channelrhodopsins. The spread of the AAV infection and the co-localisation of fluorescence-tagged channelrhodopsin with a neuronal marker (microtubule-associated protein 2, MAP2) were determined by immunohistochemistry and confocal scanning of paraformaldehyde-fixed brain slices.

AAV mediated gene delivery reliably drove neuronal-specific expression of channelrhodopsins in the inferior colliculus (IC) and other auditory nuclei. Viral transduction of neurons in these nuclei with channelrhodopsin variants enabled us to control neuronal activity with light of appropriate wavelengths. Performing current-clamp recordings we determined maximum firing rates, firing reliability and jitter of elicited action potentials. Transitions from peak to stationary current (tin), current kinetics after light-off (toff) and maximum photocurrents were measured in voltage-clamp mode. Our results represent a first step to establish optogenetics in the auditory system of the Mongolian gerbil and might aid to decipher the intricate connectivity of auditory nuclei.

Optical Imaging: A Comparison of Two Methods in Mice and Birds

Neethu Michael, Nina Keary², Uwe Mayer², Hans-Joachim Bischof², Siegrid Löwel¹

¹Systems Neuroscience Group, Johann-Friedrich-Blumenbach-Institut für Zoologie und Anthropologie, Bernstein Fokus Neurotechnologie, Universität Göttingen, Göttingen

²Lehrstuhl Verhaltensforschung, Universität Bielefeld, Bielefeld, Germany

Optical imaging of intrinsic signals (OIS), which is based on changes in the oxygenation of the blood due to neuronal activity after sensory stimulation, is a well-established method to visualize large-scale neuronal activity patterns in the brain. Another method to visualize brain activity is Flavoprotein autofluorescence imaging (AFI). In contrast to OIS, it is a direct (i.e. non hemodynamic) measure of neuronal metabolism and exploits the autofluorescence of the mitochondrial flavoprotein which is enhanced during cellular activity. Both methods allow visualization of brain activity induced by sensory stimulation. For example, topographic mapping of visual space has been shown in the visual cortex of mice by both OIS (Kalatsky & Stryker 2003, Lehman & Löwel 2008) and AFI (Shibuki *et al.* 2003, Tohmi *et al.* 2006), as well as by OIS for the visual wulst, the visual cortex analogue in birds (Keary *et al.* 2010). Because OIS depends on the blood flow and sometimes blood vessel artifacts are prominent and obscure activity maps, we wondered whether AFI would also work in the visual wulst of zebra finches.

To this end, we compared neuronal activity patterns imaged with both AFI and OIS in zebra finches, and for comparison also in C57Bl/6J mice. We analyzed visual wulst activity in zebra finches, a frequently used model for visual system investigations in laterally eyed birds after visual stimulation with moving bars on a monitor, and compared our results with activation of the visual cortex in mice using the same setup and stimulation method. Clear retinotopic maps were obtained by both methods in both species, and the occurrence of artifacts caused by blood vessels were generally reduced when using the AFI method in zebra finches. Quantitative analysis shows that in zebra finches the magnitude of neuronal activity detected by AFI was significantly higher than that obtained by OIS. Moreover, the map quality of the retinotopic maps was significantly better in the maps acquired with AFI compared to OIS. In contrast, the measurements in mice did not show any quantitative differences between the two methods. Taken together, our results indicate that for investigations in mice both AFI and OIS are equally useful while AFI might be the method of choice for investigations of visual processing in zebra finches.

Supported by the DFG Lo 442/8-1 and Bi 245/21-1

Targeted-Esterase induced Dye loading (TED) assisted ER calcium imaging is improved with a new red-fluorescent esterase construct

Samira Samtleben, Caroline Fecher¹, Robert Blum¹

¹University of Wuerzburg, Institute for Clinical Neurobiology, Versbacherstrasse No.5, 97078 Wuerzburg, Germany

In neurons calcium signaling is involved in regulation of gene expression, differentiation, transmitter release, and neuronal excitability. The endoplasmic reticulum (ER) is particularly important in calcium homeostasis because it serves as an intracellular store for freely diffusible calcium ions. These calcium ions (Ca^{2+}) are released from the ER and enter the cytosol by certain intracellular signaling cascades. Furthermore, calcium can flow into a cell's cytosol via ion channels from the extracellular space. The spatial and temporal interplay of these two kinds of calcium signals for regulation of neuronal plasticity is not well defined. This project aims to improve imaging methods for the direct monitoring of ER calcium dynamics.

In recent studies, we introduced a new method that enables the direct visualization of ER calcium signals in neuronal cells: Targeted-Esterase induced Dye loading (TED) is an advancement of classical life-cell Ca^{2+} imaging strategies using synthetic Ca^{2+} -indicators.¹ TED depends on targeted overexpression of a carboxylesterase (CES2) in the ER of cells using lentiviral expression vectors. This carboxylesterase then releases low-affinity Ca^{2+} -sensitive, fluorescent indicators in the ER, where they, upon binding of calcium ions, fluoresce. Here, we introduce new recombinant constructs for TED application. Changes in the ER translocation signal peptide improved the luminal targeting of the TED construct. In addition, we fused CES2 with a red fluorescent protein (Tag-RFP-T2) which allows simultaneous two color imaging of dynamic or steady-state calcium signals in the ER lumen. The construct has no tendency to cluster, is evenly distributed in the ER lumen and is not toxic upon overexpression. The RFP signal is bright enough to enable the identification of transduced cells, thus enabling TED with cellular-specificity.

By combining the TED strategy with the low-affinity Ca^{2+} -indicator Fluo5N, AM we are able to visualize calcium signals in cell lines, cultured glia cells and hippocampal neurons.²

Glia cells and cell lines can be imaged using a vector construct driven by the ubiquitin-promoter, whereas neurons are imaged with a CamKII promoter construct.

In cultured glia cells, we directly observed the release of Ca^{2+} upon stimulation with ATP via the GPCR, G-protein, PLC, IP_3 pathway and upon stimulation with glutamate via the same pathway. Interestingly, ER calcium is not restored from the cytosol and refilling of the ER calcium store depends on extracellular calcium, most likely through store-operated calcium entry.

Hippocampal neurons reacted by filling up their free ER calcium due to excitatory stimuli. Ca^{2+} -release from the ER could be induced using caffeine which activates ryanodine receptors. We will now use our TED-based assays to analyze ER-derived calcium signals in neuronal subcompartments.

The final aim is to unravel temporal and spatial aspects of calcium signals that are caused by the neurotrophin brain-derived neurotrophic factor.

1. Rehberg et al., Cell Calcium (2008)

2. Samtleben et al., Journal of Visualized Experiments (in press)

Acquisition of multineuronal spike events from brain slices

Kai Gansel, Wolf Singer^{1,2,3}

¹Max-Planck-Institute for Brain Research, Deutschordenstrasse 46, 60528 Frankfurt am Main, Germany

²Frankfurt Institute for Advanced Studies, Johann-Wolfgang-Goethe University, Frankfurt am Main, Germany

³Ernst-Strüngmann-Institute (ESI) for Neuroscience in Cooperation with Max-Planck-Society, Frankfurt am Main, Germany

Studying the organization of multineuronal activity at millisecond time resolution makes it obligatory to simultaneously record from multiple single neurons with multiple electrodes. Here we present a new technique for the acquisition of multineuronal spike events from brain slices. Recording from an isolated piece of neural tissue allows the investigation of its inherent properties independently of long-range connections and sensory input. This *in vitro* approach closes the gap between *in vivo* recordings and neuronal network simulations and is best suited to validate network models on the basis of real empirical data.

Until now, multi-site recordings of single-unit spike activity in acute brain slices have been reported on only a few occasions and did not follow any standardized practice. Problems arise in particular when using flat electrodes because spikes can be recorded only from the surface of the slice where most cells are damaged as a result of the slicing procedure, and because spike recording requires auxiliary techniques to assure proper contact of the tissue with the electrodes. To resolve these problems, we designed a novel experimental setup that enables the recording of field potentials and spikes from cells located at any depth in the slice using a matrix of 1.5 millimeters long, sharpened electrodes. The setup allows the observation of a large, random set of neurons of which a subset might participate in a given cell assembly. Subsequent analysis allows interference of assembly properties. A second electrode array with flat electrodes is included to apply spatiotemporal electrical stimulation patterns. Alternatively, the electrical stimulation may readily be replaced by or combined with optical stimulation and observation of the tissue.

The versatility of the experimental setup, together with the possibility to pharmacologically control the network under investigation, makes this integrated recording and stimulation system a valuable tool for the analysis of multineuronal dynamics *in vitro*. All components of the setup are described in detail, including the design of the recording chamber. The quality of the recordings as well as the functionality and performance of the method are demonstrated by analyzing responses of cortical brain slices to electrical stimulation under different pharmacological conditions.

Automated analysis of spontaneous synaptic activity in whole cell current clamp recordings

Alexander Drakew, Urban Maier¹, Anja Tippmann¹, Michael Frotscher¹

¹Zentrum für Molekulare Neurobiologie Hamburg, Universitätsklinikum Hamburg-Eppendorf, Institut für Strukturelle Neurobiologie, Falkenried 94, 20251 Hamburg, Germany

We aimed to develop a fully automated method allowing for effective quantitative analysis of the spontaneous synaptic activity of single recorded neurons. The postsynaptic potentials (PSPs) as well as the action potentials (APs) recorded from a neuron reflect the spontaneous synaptic network activity at the single cell level. This spontaneous synaptic activity is preferentially monitored in the whole cell current clamp mode. However, a quantitative analysis of the resulting voltage traces is demanding due to the large amount of events and the significant piling up of PSPs with the next PSP starting on top of its not yet decayed predecessor. We here suggest a novel method to overcome these issues.

The suggested approach performs the analysis in 3 steps: 1. Detection of events, 2. Definition of the fluctuating baseline, 3. Quantitative measurements on all detected events. Step 1 is based on a voltage-deconvolution approach introduced by Richardson and Silberberg (2008). This results in a transformation of wide pulses into sharp narrow peaks and thereby largely eliminates piling up of clustered events. Step 2 then follows the simple notion that the baseline is visible where there are no peaks. However, this is not very useful in the common case of series of piled-up PSPs. Therefore, the baseline is extracted from the deconvolved voltage trace and then reconvolved to obtain a more or less fluctuating baseline of the original recording. After subtraction of this baseline from the recorded voltage in step 3, the result is fitted to a sum of exponential pulse functions that describe any event by 4 parameters: time of onset, peak amplitude, and time constants of the rising and the decay phase. Finally the distributions of these parameters represent the synaptic activity in one neuron in a quantitative manner that can be compared between cells and conditions.

In order to evaluate the suggested method, we analyzed simulated voltage traces that were constructed from various baselines and exponential peak functions.

We will present the application of this method by analyzing the spontaneous synaptic activity of hilar mossy cells in organotypic entorhino-hippocampal slice cultures of synaptopodin knockout mice, which do not form a subcellular organelle, the spine apparatus, in comparison to the activity in slice cultures from wildtype mice. The spine apparatus is mainly present in large dendritic spines, in particular in the hippocampal complex spines postsynaptic to mossy fiber boutons. The spine apparatus has been suggested to contribute to potentiation at excitatory synapses. Therefore, one would expect to find changes in the distribution of PSP amplitudes in the absence of spine apparatuses in synaptopodin mutant mice, if the spine apparatus is of relevance for spontaneous neuronal communication.

Reference: Magnus J. E. Richardson and Gilad Silberberg (2008) Measurement and Analysis of Postsynaptic Potentials Using a Novel Voltage-Deconvolution Method. *J. Neurophysiol.* 99: 1020–1031.

Response properties of the genetically-encoded optical H_2O_2 sensor HyPer

Jonathan Weller, Michael Müller¹

¹Universitätsmedizin Göttingen, Zentrum Physiologie und Pathophysiologie, Humboldtallee 23, D-37073 Goettingen, Germany

ROS (reactive oxygen species) play a crucial role in the progression of various neuropathologies. Hence there is a tremendous interest in optical markers for the dynamic recordings of cellular ROS levels. In the past, organic dyes were used to visualize ROS formation, but these indicators combine major disadvantages such as phototoxicity, photobleaching, autooxidation, and irreversible oxidation. Therefore, various genetically-encoded ROS sensors have been developed. We evaluated the ROS sensor HyPer in hippocampal cell cultures. HyPer consists of a circularly permuted yellow fluorescent protein (YFP) inserted into the prokaryotic H_2O_2 -sensing protein OxyR (Belousov et al. 2006, Nat Methods 3: 281-286). HyPer was reported to respond specifically to H_2O_2 . It exhibits two distinct absorption peaks responding oppositely to oxidation, thereby enabling ratiometric and quantitative analyses.

We tested a cytosolic and a mitochondria-targeted isoform of HyPer. Cell cultures were transfected by lipofection, neurons and glial cells showed a sufficient expression within 3 days, and HyPer was distributed homogenously within the cytosol or the mitochondria. Excitation was performed at 420 nm and 490 nm and the emission ratio 490/420 nm was calculated. Administration of H_2O_2 (3 min) increased absorption at 490 nm and decreased absorption at 420 nm, accordingly the emission ratio of cytosolic HyPer rapidly increased within 1-2 min. Upon wash-out the ratio fully recovered within ~10 min. The dose-response yields an EC_{50} of ~50 μM H_2O_2 , and full oxidation was obtained with concentrations =200 μM H_2O_2 . Repeated exposure to H_2O_2 caused a decline of HyPer responses by ~30%. At higher H_2O_2 doses a response plateau was not reached, instead the ratio started to decrease again while H_2O_2 was still present. Furthermore, dithiothreitol (10 mM) only induced a moderate reducing shift. Mitochondrial inhibition by cyanide (1 mM, 3 min) or block of superoxide dismutase by DEDTC (50 μM , 5 min) clearly increased the HyPer ratio, and HyPer also responded to tert-butyl hydroperoxide (20 μM , 3 min). Anoxia evoked a biphasic response consisting of an initial reduction and a secondary oxidation upon reoxygenation. Since especially YFP is pH-sensitive, we provoked changes in intracellular pH. In response to propionate (30 mM, 15 min), which evokes an acidosis and a rebound alkalosis upon washout, the HyPer ratio decreased and a more prominent increase occurred upon propionate removal. Replacing 50% of extracellular Cl^- by methylsulfate only caused a moderate decrease in HyPer ratio.

Mitochondria-targeted HyPer brightly labeled these organelles, revealing also information on mitochondrial morphology and dynamics. H_2O_2 administration induced a clear increase in fluorescence ratio in individual mitochondria, thereby revealing information on the single organelle level and potentially differences within the mitochondrial population. Yet, in view of the pronounced modulation by pH changes, the adaptation to repeated oxidation and a lack of clear responses to reducing stimuli, HyPer responses should be interpreted with caution. By offering the opportunity of dynamic recordings, HyPer seems superior to the organic dyes which are still widely used for ROS recordings. Nevertheless, other genetically-encoded ROS indicators - such as the reduction/oxidation sensitive green fluorescent proteins (roGFPs) - yield more reliable and more stable responses to ROS and redox changes.

Supported by the DFG Research Center Molecular Physiology of the Brain (CMPB)

Testing and Improvement of a Spike Sorting Algorithm

Christopher Doerr, Dirk Hoehl², Uwe Thomas², Thomas Schanze¹

¹Technische Hochschule Mittelhessen, FB KMUB, Gießen, Germany

²Thomas RECORDING GmbH, Gießen, Germany

Extracellular recordings with multi-channel fibre electrodes, e.g. tetrodes, are increasingly used to study neuronal information processing. Each recorded signal generally contains action potentials (spikes) of several neurons and, unavoidably, artifacts and noise. These signals must be processed and sorted correctly into spike trains of individual neurons.

We adopted a spike sorting algorithm recently developed and provided by Franke et al. [1] and tested its performance for various parameters by using simulated signals with known properties that were in accordance with real data. The performance of the sorting process was quantified via the receiver-operating-characteristic (ROC) analysis. The results indicate that the performance of spike sorting strongly depends on algorithm's parameters [2].

Besides quantitative analysis, the visual inspection of data and sorting results is important to assess the properties and performance of the algorithm. To improve usage and control of the algorithm we developed a graphical user interface that provides an interactive workplace (Fig. 1).

Simple thresholding of the responses of the spike-waveform filters is not sufficient for reliable spike detection. Theoretically, the filters should respond to a spike with a sharp peak [1]. However, some filters respond with frayed or multiple peaks. This results in many false-positive detections with very small interspike-intervals of about 1 ms or less, thus mas-sively deteriorating the performance.

As a solution, we incorporated an additional parameter called absolute refractory period. Peaks found within this period are merged to one event, where the topmost peak is used to mark the spike by a predefined colour in a window (Fig. 1). All rejected spikes are displayed in gray. This supports the user to optimize parameters and to control the effect, especially when signals of bursting neurons with small interspike-intervals are present. Since one filter output corresponds only to a single unit, no additional false negative classifications are expected. Thus the spike sorting performance has been greatly improved.

References:

- [1] F. Franke, M. Natora, C. Boucsein, M. Munk, K. Obermayer: An online spike detection and spike classification algorithm capable of instantaneous resolution of overlapping spikes. *J. Comput. Neurosci.*, 127-148, 2009.
- [2] C. Doerr, D. Hoehl, U. Thomas, T. Schanze: ROC-testing of a spike sorting algorithm. *Biomed. Tech.* 2012, Vol. 57 (suppl. 1), 2012, DOI: 10.1515/bmt-2012-4419

Acknowledgements: Thanks to Prof. K. Obermayer, TU Berlin, and his colleagues for providing us with their spike sorting program.

Figure 1: Screenshot of the spike sorter GUI with sorting results of a simulated tetrode recording. Four units were found. Left: Detected spike waveforms. Mid: Simulated tetrode signal. Found spikes are marked in top plot with colours corresponding to neurons. Right top: Principal components projection of

spikes. Right mid: Filter outputs correspond to neurons. Peaks indicate detected spikes, detection threshold can be varied via a slider. Right bottom: Interspike-interval histograms.

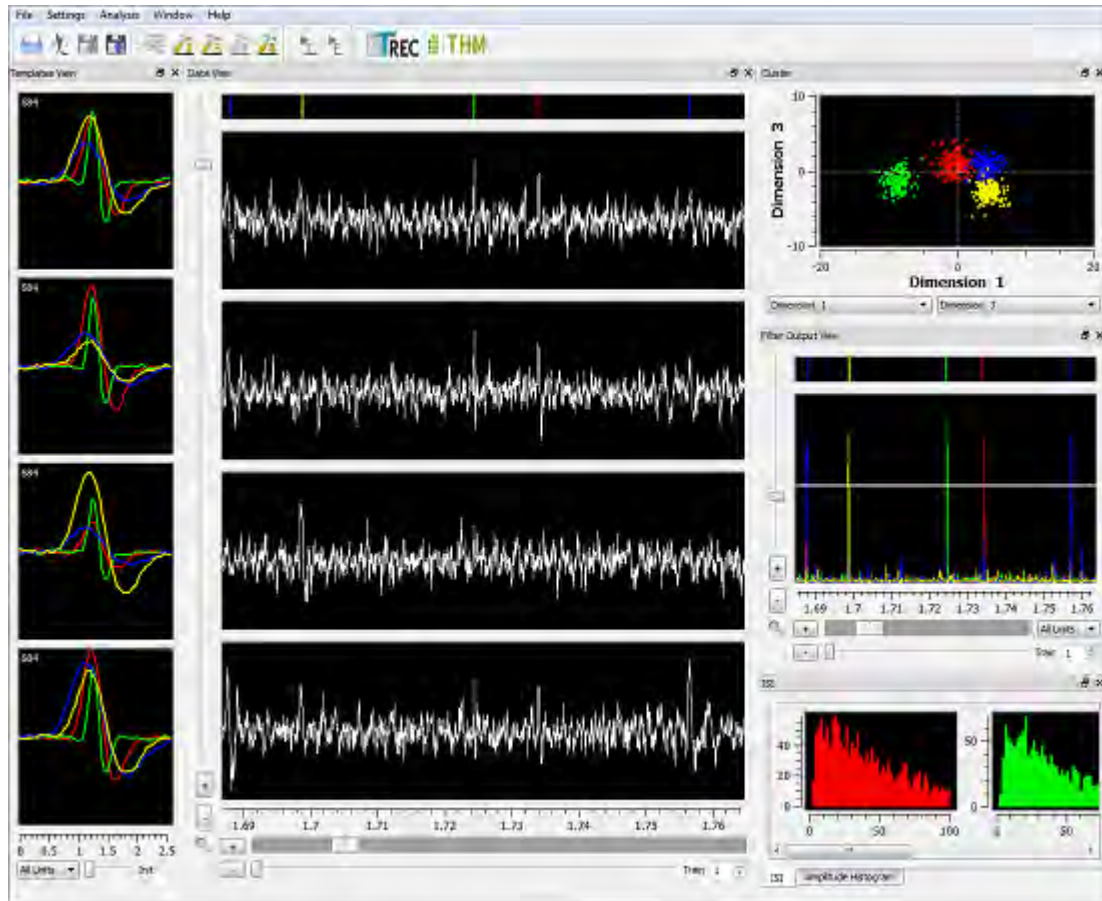

Data management for efficient and reproducible research

Andrey Sobolev, Aljoscha Leonhardt¹, Christian Kellner¹, Philipp L. Rautenberg¹,
Andreas V. Herz¹, Thomas Wachtler¹

¹German INCF Node, Department Biology II, Ludwig-Maximilians-Universität München, Germany

Recent progress in experimental neuroscience is leading to rapid proliferation of data. Availability of extra tools for data and metadata management, as well as for effortless data access becomes crucial for efficient and reproducible research. In this work we present solutions targeted to improve data access, data storage and exchange, and data analysis, as key ingredients in the field of experimental electrophysiology.

The G-Node data management platform[1] provides tools for data organization, annotation, sharing, and search as a freely available service. Based on user experience, the key principle of the platform is the integration of the cloud-based data management into the laboratory workflow, making it possible for scientists to work with their data and metadata directly from their analysis environment, such as Matlab[2] or Python[3]. The interface provides functions for easy and flexible metadata management, consistent data organization, and annotation. Data and metadata can be synchronized to the server (locally within the lab when fast and instant access is needed, or remotely for access from different locations). Within the platform, data is stored in an open format[4][5], where key objects like recorded signals, channels, spiketrains or waveforms are logically connected, providing detailed data sharing or incremental backup. The platform features powerful search and query capabilities from simple full-text search to specialized query and filter mechanisms such as data slicing, and fine-grained access control. Having data hosted at the G-Node platform, one can benefit from searching across all available experiments and datasets, both done within the home lab or shared by collaborators, by any metadata used within these research studies. The platform provides an interface useful not only to produce but also to reproduce certain scientific analysis. The system tracks changes made to the original data and metadata, thus enabling scientists to go back in time to any revision, making the reproduction of individual analysis steps effortless and transparent.

The system is based on a common data API[1], which makes it possible to access data directly from scientific applications or other client tools[2][3][7][8][9]. This enables integrating data access seamlessly within the data analysis workflow, thus fostering scientific progress through neuroinformatics.

[1] <https://github.com/G-Node/g-node-portal>

[2] <https://github.com/G-Node/gnode-client-matlab>

[3] <https://github.com/G-Node/python-gnode-client>

[4] <http://packages.python.org/neo/io.html>

[5] <https://github.com/G-Node/python-odml>

[7] <http://packages.python.org/OpenElectrophy/>

[8] <http://spyke-viewer.readthedocs.org/en/latest/index.html>

[9] <https://github.com/G-Node/crayon>

Acknowledgments: Supported by the Federal Ministry of Education and Research (Grant 01GQ0801).

Cell viability testing with a sponge alkaloid: Ageladine A indicates acidification during physiological stress and apoptosis

Ulf Bickmeyer, Kristin Tietje¹, Benedikt Hofbauer², Christine Fink³, Thomas Roeder³, Christian Wegener², Guido Schramm⁴

¹Alfred Wegener Institut, Ökologische Chemie, Am Handelshafen 12, D-27570 Bremerhaven,

²Lehrstuhl für Neurobiologie und Genetik Biozentrum Am Hubland D-97074 Würzburg,

³Zoologisches Institut, Abteilung Zoophysiologie II, Christian-Albrechts-Universität, Olshausenstraße 40, D-24098 Kiel,

⁴Ovamed GmbH Kiebitzhörn 31 D-22885 Barsbüttel

Ageladine A stems from sponges of the genus *Agelas* and belongs to the chemical group of brominated pyrrole imidazole alkaloids, which have been shown to possess a high pharmacological potential. Ageladine A can be used as a pH sensitive dye in living cells, tissues and whole organisms with apparently little side effects. Especially whole animal staining in transparent marine animals showed to be successful. The major change and increase of fluorescence in the blue to green wavelength range can be observed between 8 and 5 pH units. Dying or energy deficient cells are increasingly unable to regulate intracellular pH values due to lower transporter rates and mitochondrial dysfunction, which leads to acidification of the cytosol of at least 0.5 to 1 pH units. Ageladine shows its best sensitivity range in the most relevant pH range between pH 7 and 6 and is therefore useful for detection of small irregularities in the cellular pH homeostasis. We used PC12 cells, astrocytes, intestinal cells and neuronal cells from *Drosophila* as well as nematode eggs to demonstrate the strong fluorescence in dying cells. Taken together, Ageladine A enables to monitor pH changes induced by energy depletion up to cell death in organisms or tissues, thus allowing for life imaging of these highly important traits.

Figure: Fluorescence of astrocytes and nematode eggs stained with Ageladine A (upper images taken by Charlotte Petters and Kristin Tietje)

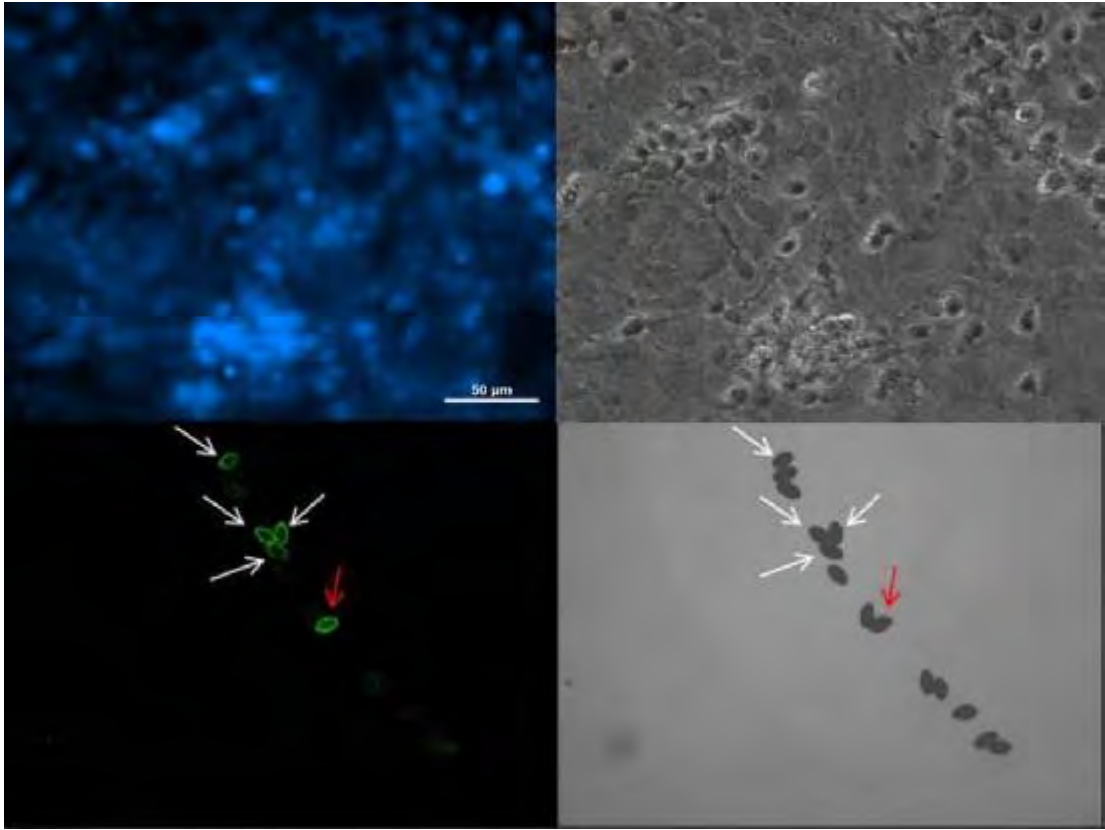

Single-Particle Tracking of Neuronal Surface Proteins in Brain Slices

Barbara Biermann, S. Sokoll¹, J. Klueva¹, M. Missler², M. Heine¹

¹Molecular Physiology / Leibniz Institute for Neurobiology Magdeburg / Germany, ²Institute for Anatomy and Molecular Neurobiology / Münster University / Germany

Surface dynamics of signaling molecules can be analyzed by single-particle tracking (SPT) using semiconductor quantum dots (Qdots) and have been widely studied in dissociated neuronal cultures. Here, we present a protocol for SPT in organotypic hippocampal slices to study single-molecule dynamics in the cellular complexity of the natural tissue.

To image Qdots in slices we use a confocal spinning disk microscope together with a 60x, NA1.1 water immersion or a 100x, NA1.4 oil objective. We initially show that the localization accuracy and the signal-to-noise ratio of Qdots are slightly reduced in slices versus dissociated neurons but deliver substantial data up to 40 microns tissue depth. We subsequently express eGFP-tagged glycosylphosphatidylinositol (GFP-GPI) in neurons and label them with Qdots coupled to monoclonal antibodies directed against GFP. As GFP-GPI is localized in the outer membrane leaflet it helps to investigate the fluidity of different membrane compartments. Furthermore, the GFP-GPI transfected neurons extend their Qdot-labeled neurites deeply into the tissue and thereby confirm the high epitope specificity. By evaluating the instantaneous diffusion coefficient of Qdot-trajectories from 2D movies we show that GFP-GPI moves slower in dendrites than in axons. We further investigate the motility of synaptic adhesion molecules and find that neuroligin-1 is highly dynamic in axons, whereas neuroligin-1 is more confined in dendrites, especially spine heads. Dual-color imaging of Qdots emitting at different wavelengths confirmed this finding. Currently, we are studying the differing mobility of candidate molecules at synaptic and extrasynaptic sites by co-expressing fluorescently labeled synaptic marker molecules like synapsin or homer.

Our data show that SPT can efficiently be applied to brain slices. The 60x water immersion objective further permits access with a micropipette to record neuronal activity and protein surface mobility simultaneously.

Calcium Imaging and Optical Manipulation of Vestibular Neurons in the Axolotl

Stephan Drenberger, Roberto Banchi¹, Christian Seebacher², Felix Felmy¹, Hans Straka¹, Lars Kunz¹

¹Ludwig-Maximilians-University, Department of Biology II, Division of Neurobiology, Munich, Germany.

²Ludwig-Maximilians-University, Department of Biology I, BioImaging Zentrum, Munich, Germany.

The combination of several imaging methods, such as calcium imaging and optical manipulation of neuronal networks becomes a progressively important feature in neuroscientific studies. Here we introduce a new epifluorescence microscope concept which enabled us to implement two spatially and temporally separated illumination pathways using low-cost, high-power LEDs. These two optical pathways can be illuminated by LEDs of various wavelengths and are independently adjustable in size and position. Image detection is realised by the latest generation of a CMOS camera providing image capturing at high resolution and speed-rates of 100 Hz at maximum resolution. Moreover, we implemented a voice-coil driven high NA objective to ensure z-movement at maximum speed and precision. The multiple LED arrangement and the separation of excitation pathways allow us to accomplish different imaging approaches simultaneously. Combining these optical features with electrical stimulations becomes a powerful tool to investigate function and connectivity of neuronal pathways.

The performance of the microscope was tested using *in vitro* whole head preparations of axolotl (*Ambystoma mexicanum*) larvae. This preparation allows studying neuronal systems with all sensory pathways intact and can be maintained up to one week. Thus, we were able to use calcium imaging to record sensory evoked neuronal responses of central vestibular neurons elicited by electric stimulation of specific semicircular canals. Further, to quantify the glutamate uncaging efficiency we calculated the required light intensity and duration to optically evoke action potentials by patching those neurons. Finally, we could show that by means of spatially separating calcium imaging and glutamate uncaging we were able to manipulate ipsilateral semicircular canal evoked calcium responses by optically activating contralateral inhibitory/excitatory pathways.

Conditional photolabeling of individual neurons in transgenic mouse lines *in vivo*.

Manuel Peter, Brice Bathellier¹, Bruno Fontinha¹, Simon Rumpel¹

¹Research Institute of Molecular Pathology (IMP), Circuit Neuroscience, Dr. Bohr Gasse 7, 1030 Vienna, Austria

A future challenge in neuroscience will be to explain specific functional properties of individual neurons *in vivo* based on their molecular identity and/or their connectivity within the neuronal circuit. Calcium imaging *in vivo* allows functional characterization of large populations of neurons *in vivo* in the context of sensory stimulation or a behavioral task. However, calcium imaging itself does not provide information about the cell type or connectivity. To link functional characterization of a neuron with a connectivity analysis or histological analysis it would be desirable to label selected neurons *in vivo* and then transfer this information to a slice preparation.

Photoactivatable proteins allow conditional labeling of individual cells as these fluorescence proteins change their fluorescence upon irradiation with light of a certain wavelength. We created transgenic mouse lines which express photoactivatable GFP under the control of the constitutively active *Thy1* promoter or in a Cre dependent manner from the *Rosa26* locus. We found that these mouse lines show strong and constitutive expression of the transgene. Furthermore, using two-photon excitation single neurons can be labeled *in vivo* with high precision and the label is detectable at the soma for many hours. Individual neurons photolabeled *in vivo* can be re-identified in acute brain slices and targeted for electrophysiological recordings. Furthermore they can be re-identified in fixed brain slices which allows a further characterization of their expression profile. We demonstrated this by correlating *in vivo* functional calcium imaging with a post-hoc histological analysis of the immediate early gene *c-fos*. We observed that neurons can have very different *c-fos* expression levels independent of their firing rates and that on the population level no significant differences were observed between highly active and weakly active neurons suggesting that additional factors besides neuronal activity could in addition have a strong influence on the level of Fos expression in individual neurons under basal conditions.

Currently we are working on a second generation of PA-FPs expressing mice with improved labeling intensity and life-time and also different spectral variants that will offer an even higher flexibility in experimental approaches. We think that these mouse lines will be an enabling tool for a wide range of experiments in which several analytical approaches, including functional ones, are combined with a further characterization of the same, photolabeled neurons.

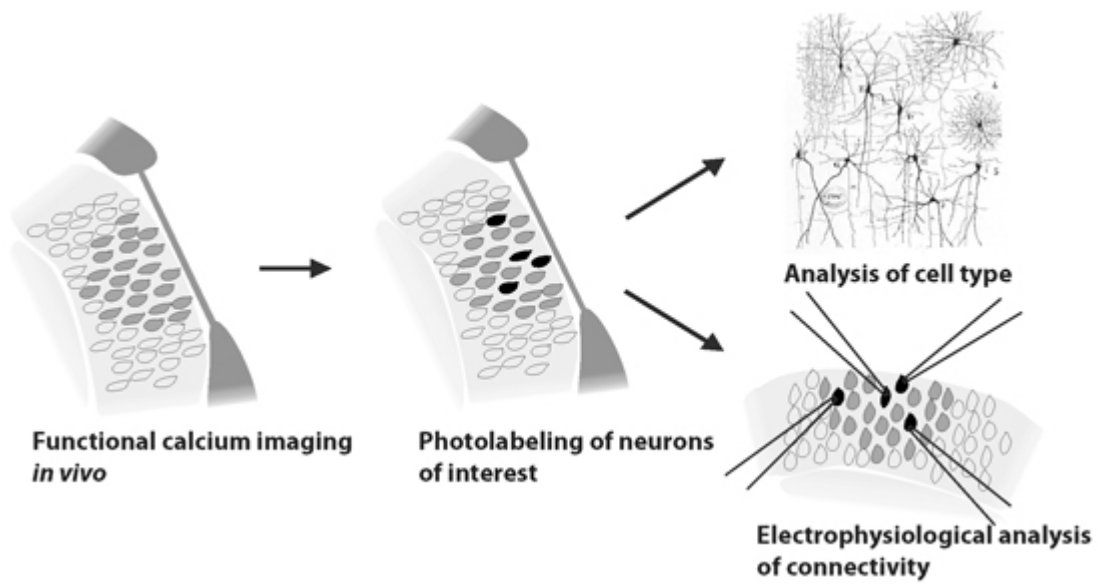

BONCAT and GINCAT - Or how to tag newly synthesized proteins with a click

Anke Müller , Christine Freitag ², Thilo Kähne ³, Daniela C. Dieterich ^{1,2}

¹Otto von Guericke University Magdeburg, Institute for Pharmacology and Toxicology, Magdeburg, Germany

²Emmy Noether Research Group Neuralomics, Leibniz Institute for Neurobiology, Magdeburg, Germany

³Otto von Guericke University Magdeburg , Institute for Experimental Medicine, Magdeburg, Germany

Dynamic protein synthesis is a common feature of cells and organisms to react to changes in their environment and is, therefore, of particular interest. Thus, it is a well-known fact that synaptogenesis, as well as long lasting forms of synaptic plasticity are characterized by dynamic changes of the neuronal proteome. However, the emerging concept of the Tripartite Synapse points to the likewise importance of glia cells for neuronal function and development. Although it is well established that astrocytes are important for the formation and maintenance of synaptic contacts, sense neuronal activity and actively participate in homeostatic scaling, it is unclear if the astroglial cell is as dynamic as the neuronal one. To answer this question it is vital to monitor changes of individual, i.e. neuronal and astroglial, proteomes. To enable metabolic labeling of newly synthesized proteins, we use a recently introduced technique, which is called BONCAT (bioorthogonal non-canonical amino acid tagging). Based on BONCAT we developed GINCAT (genetically introduced non-canonical amino acid tagging) for the identification of changes in protein synthesis in a subtype of cells of a mammalian co-culture system. Different amino acid residues of the methionyl-tRNA-Synthetase (MetRS) were exchanged to enable the incorporation of the non-canonical amino acid azidonorleucine (ANL) into newly synthesized proteins. A single amino acid substitution within the methionine-binding pocket of MetRS was found to be most effective for ANL activation and incorporation into proteins and was further used to analyze cellular consequences of ANL integration into proteins. Incorporation of ANL is specific for cells carrying the mutated enzyme and application of ANL to cells and integration of ANL into proteins have no effect on cell viability. Furthermore, no differences can be detected regarding protein processing and ubiquitination between cells incorporating either methionine or ANL into proteins. Cell specific expression of LtoGMetRS in GFAP positive cells in a glia-neuron co-culture system allows cell specific ANL integration and enables not only the visualization of astroglial new protein synthesis using a fluorescent-tag in the subsequent 'click chemistry' reaction but permits also the purification of astroglial proteins like GFAP or Cnx43 as well as the enrichment of ANL labeled proteins for mass spec analysis applying a Biotin-tag. These results so far promote the idea to use GINCAT for the analysis of a cell specific proteome in a complex cellular environment such as glia-neuron co-cultures, and, therefore, GINCAT may improve our understanding of neuron-glia communication and interaction both in vitro and in vivo.

Sufficient across-tip diffusion occurs with sharp microelectrodes filled with high ionic-strength solutions to alter membrane conductances within typical experimental durations

Jeffrey Bryan Thuma, Christoph Guschlbauer^{1,2}, Ansgar Büschges², Scott Llewellyn Hooper¹

¹Ohio University, Dept. of Biological Sciences, OH 45701 Athens, USA

²University of Cologne, Dept. of Animal Physiology, 50674 Cologne, Germany

Early work in which amphibian red blood and epithelial cells were recorded from with sharp electrodes filled with high ionic strength solutions has shown that sufficient ion diffusion occurs across the electrode tip to cause water flow across the membrane and cell swelling (Stoner et al., 1984). Despite this, all modern sharp electrode neurophysiology, to our knowledge, is performed with electrodes filled with much higher ionic osmolarity solutions than that of neuronal cytoplasm. We have tested whether this use is a concern in neurophysiology in three ways. First, we repeated the early work using electrodes filled with radioactively-labeled glucose and verified that sufficient diffusion occurs across sharp electrode tips that it would indeed be expected to alter neuron soma ion concentrations. Second, we performed two-electrode recordings from Pyloric Dilator neurons of the stomatogastric ganglion of the lobster, *Panulirus interruptus*, with electrodes filled with normal stomatogastric (2.5 M KAc, 20 mM KCl), high ionic-strength (6.5 M KAc, 20 mM KCl), and squid giant axon cytoplasm-mimicking (50 mM Na, 400 mM K, 40 mM Cl, 10 mM Mg) solutions, all buffered to pH 7.2 with HEPES. Steps to a variety of membrane potentials were performed under voltage clamp, and the opening/closing time constant of the hyperpolarization-activated cation conductance I_h , and the amplitude of a transient depolarization-activated outward current (a combination of I_A and K_{Ca}), were measured every 10 minutes for 50 minutes. These data showed that I_h 's opening/closing time constants were up to 2-fold longer in the neurons recorded from with electrodes filled with low ionic strength solutions compared to the time constants measured in neurons recorded from with high ionic strength electrodes. In the high ionic strength electrode fill, the amplitude of the transient outward current continuously decreased over the 50 minute recording time, typically to zero by the end of the experiment. In the low ionic strength electrode fill experiments, alternatively, transient outward current amplitude remained relatively constant. Third, we performed similar dual electrode recordings with low, standard, and high ionic strength electrode fills from leech Retzius neurons. These neurons showed only very small I_h and transient outward currents, and we have not yet measured their dependence on electrode fill. However, these experiments showed that with high ionic strength electrodes the neurons swelled dramatically, and neuron membrane resistance consistently decreased over the 50 minute recording sessions. With low ionic strength electrode fills, alternatively, no swelling or consistent changes in membrane resistance occurred. These data thus demonstrate in both lobster and leech neurons that using high ionic strength electrode fills changes neuron cell properties over typical experimental recording durations. Low ionic strength electrode fills should thus be used in experiments measuring neuron cell properties, and prior work with high ionic strength electrode fill solutions must be viewed with caution.

Analysis of infection efficacy, tropism, immunogenicity, and axonal transport of rAAV serotypes in the mouse brain

Dominik Florian Aschauer, Sebastian Kreuz², Simon Rumpel¹

¹IMP, Research Institute of Molecular Pathology, Vienna, Austria

²Target Discovery Research at Boehringer Ingelheim, Biberach, Germany

A key goal of modern neuroscience is to understand the principles of information processing in neural circuits. This requires characterization of the involved cells and their connections, and the ability to measure and perturb their activity. One way to get access to these complex neural systems is through genetic approaches.

Besides the well-described use of transgenic and knockout mouse models, the application of viral vector-mediated gene transfer represents an alternative approach, allowing for efficient gene targeting in a temporally and spatially restricted manner. Recombinant Adeno-associated viruses (rAAV) are widely used in rodents in neuroscience research due to their ability to allow for long-term expression of a transgene in postmitotic cells combined with very low cytotoxicity.

Currently, over 100 different AAV serotypes have been isolated from different species and more than ten have been engineered for application as recombinant viral vectors up to now. Serotypes are defined by differences in their capsid, which strongly influences the major steps of viral transduction. This implies that different serotypes may be better or worse suitable for a specific application. To make the optimal choice of rAAV, the transduction properties of different AAV capsid variants in the mouse brain need to be studied in a comparative manner.

Here, we investigated characteristics of six different AAV serotypes for their use in neuroscience research. For our study, we produced rAAV particles with different serotype capsids containing the same reporter construct expressing GFP under control of the ubiquitous CMV-promoter. We performed a histological analysis of the expression patterns three weeks after stereotaxic injection. Specifically, we analyzed a) the efficacy of transducing three important areas in the brain (neocortex, hippocampus, and striatum), b) the preference for infecting a particular cell-type in the brain (neurons, inhibitory neurons, astrocytes, microglia, oligodendrocytes), c) the occurrence of an innate immune response, and d) the possible transportation of viral particles along known connections between brain regions.

Our results show that, indeed, there is a great difference in transduction efficacy between different serotypes that appears rather independent of the brain areas targeted in our study. Moreover, based on relative reporter gene expression, we find that particular serotypes are more efficient in targeting specific cell types as compared to others (e.g. rAAV8 showing a strong bias for targeting of astrocytes). After rAAV application, we did not observe an increase in the numbers of microglial cells at the infection site. This strongly argues against an innate immune response, as it occurs following the application of lipopolysaccharide (LPS), which we used as a positive control. With respect to spreading/transport of different AAV serotypes, we interestingly found that rAAV5 - in contrast to the other AAV serotypes investigated here - is retrogradely transported to a specific population of layer 2/3 neurons of the entorhinal cortex after infection of hippocampal axon terminals.

In summary, our study provides a comprehensive guideline to choose among the currently most commonly used rAAV serotypes for gene targeting in the mouse brain.

In vivo imaging of PKA activation in the striatum using an optical fiber bundle and biosensor.

Pierre Vincent, Marina Brito¹, Elvire Guiot¹, Liliana Castro¹, Jin Zhang², Danièle Paupardin-Tritsch¹

¹CNRS and UPMC, UMR7102 Neurobiologie des Processus Adaptatifs, Paris, France.

²Department of Pharmacology and Molecular Sciences, The Johns Hopkins School of Medicine, Baltimore, USA.

A number of neuropsychiatric pathologies are related to dysfunctions in neuromodulatory systems. Among the various intracellular signaling cascades triggered by neuromodulators, the signaling pathway regulated by cyclic adenosine monophosphate (cAMP) is an archetype known in great details at the molecular level. At the cellular level, the cAMP/PKA cascade is responsible for the modulation of various processes in the brain, including some specific forms of synaptic plasticity, control of excitability, regulation of nuclear factors and imprinting of long-term changes. In the striatum, dopamine activates the cAMP/PKA signaling cascade in medium spiny neurons of the direct pathway via D1 receptors whereas dopamine inhibits the same signaling cascade in medium spiny neurons of the indirect pathway via D2 receptors.

How these signaling events take place in the spatial and temporal domains of the living neuron was difficult to study. Biosensor imaging now allows direct monitoring of changes in cAMP concentration or PKA activation in living neurons in brain slice preparations (see our other posters). However, the brain slice preparation is inherently deprived of inputs. We wanted to go one step further and record intracellular PKA signals in the context of the living animal.

Optical methods are usually restricted to superficial structures of the brain because of light absorbance and scattering in the tissue. We used a novel instrument based on a bundle of optical fiber with 488 nm excitation and simultaneous detection at two wavelengths, allowing ratiometric quantification. This instrument was developed by Mauna-Kea Technologies, Paris. We designed and characterized a new PKA-sensitive biosensor with the GFP/dTomato fluorophore pair suitable for this instrument. This genetically encoded biosensor was expressed in the striatum via in vivo viral transduction, and the fluorescence was monitored in real time by placing the tip of the optical bundle in the striatum in vivo. Using this approach, we imaged for the first time PKA activation in the striatum in response to i.v. injection of a dopamine D1 agonist.

We believe that this novel methodological approach will open new ways of monitoring cellular responses to physiologically relevant stimuli and allow for the evaluation of CNS drugs in vivo.

Improving multi-photon imaging to study olfactory coding in insects

Georg Raiser, Marcel Wunram², Sabine Scheibe³, C. Giovanni Galizia¹

¹University of Konstanz, Dept. Neurobiology, Universitätsstr. 10, 78457 Konstanz, Germany

²University of Konstanz, Dept. Photonics, Universitätsstr. 10, 78457 Konstanz, Germany

³Ludwig-Maximilians University Munich, Biolmaging Center, Großhaderner Str. 2 -4, 82152 Martinsried, Germany

Unraveling the mechanisms of brain dynamics is a very exigent task from the technological perspective, since it requires simultaneous high temporal and spatial resolution from as many neurons as possible.

Multi-photon imaging provides key advantages compared to other approaches, such as parallel probing of many cells in comparison to electrophysiology, or optical sectioning compared to conventional imaging. However, main caveats such as the low temporal resolution of typically few tens of Hz, or the damage caused by the high laser power needed to achieve deep tissue penetration are hindering its applicability in many experimental situations. Additionally, its widespread usage suffers from the prohibitively high costs of both the required pulsed Ti:Sa laser and the microscope platform itself.

Here we present a multi-photon microscope using a Erbium:Fiber laser, outputting a broad excitation spectrum ranging from 900 to 1400 nm compressed to sub 20 fs pulses that leads to 3-photon excitation. The short pulses allow us to keep the average energy low, thereby causing less photodamage in the sample.

In combination with a basic microscope stage equipped with a high performance xyz-scanning unit, we are able to limit the scan to arbitrary trajectories in 3 dimensions, thereby minimizing scanner dead time and maximizing the sampling rate.

We show the feasibility of the imaging setup by presenting stimulus-response measurements from the olfactory system of both the fruit fly *Drosophila melanogaster* and the honey bee *Apis mellifera*.

Systematic Individual Differences in Spatial Navigation - an Online Study

Caspar Mathias Goeke, Peter König^{1,2}, Klaus Gramann^{1,3,4}

1. University of Osnabrück, Institute of Cognitive Science, Osnabrück, Germany

2. Dept. of Neurophysiology and Pathophysiology, University Medical Center Hamburg-Eppendorf, Hamburg

3. Biological Psychology und Neuroergonomics, Technical University Berlin, Berlin

4. Institute for Neural Computation, University of California, San Diego

Research in spatial navigation revealed the existence of different strategies defined by the use of distinct reference frames. However, there is little knowledge about the factors contributing to individual differences and how such strategies are distributed among the population. Here we investigated the distribution of navigation strategies as a function of gender and video gaming experience in a large population.

In an online experiment, participants watched videos of virtual passages through a star-field (Fig 1A) with one turn in either the horizontal (yaw) or the vertical (pitch) axis (Fig 1B). At the end of a passage they selected one out of four homing arrows to indicate the initial starting location (Fig 1C). To solve the task, participants could rely on either an egocentric or an allocentric reference frame. Hence one arrow always represented the egocentric strategy; a second opposite arrow always represented the allocentric strategy, while the two remaining arrows oriented along the orthogonal axis were used as catch (incorrect) responses. Of the 426 participants a total of 373 datasets were complete and usable for further analysis.

The majority of subjects (335/373) consistently used the same strategy in more than 75% of all trials (Fig 1D). With that approach 35.6% of all participants were classified as Turners (consistently using an egocentric reference frame on both axes) and 47.2% as Nonturners (consistently using an allocentric reference frame on both axes). 7.8% of all participants consistently used an egocentric reference frame in the yaw plane but an allocentric reference frame in the pitch plane (Switcher). Average response latencies revealed differences between strategy groups (Table 1) and responses based on the non-preferred reference frame were significantly slower (6.45 s, $sd=7.75$) compared to trials where the participants used their preferred reference frame (1.88 s, $sd=1.07$; Fig 1E). Using consistency as a covariate eliminated the differences in reaction time between strategy groups.

Investigating the influence of gender on navigation strategies revealed that females predominantly used the allocentric strategy while males used both the egocentric and the allocentric strategy with comparable probabilities (Table1). Men demonstrated significantly faster responses than women. However, men also showed a higher level of video gaming experience than women, which was negatively correlated with reaction time. Controlling for video gaming experience eliminated the difference in reaction time between men and women.

Based on a strong quantitative basis with the sample size about an order of magnitude larger than in typical psychophysical studies these results demonstrate that most people reliably use one out of three navigation strategies (egocentric, allocentric, mixed) for spatial updating and provide a sound estimate of how those strategies are distributed within the general population. Importantly, we demonstrate that response time differences in this navigation task are related to differences in the underlying cognitive processes (consistent vs. inconsistent responses) and varying experience with virtual tasks respectively, but not to the preferred strategy or gender of participants.

Number of Subjects (N) / Mean Response Time (s)	Turner	Nonturner	Switcher	No Pref	Total
Males	N= 84 / RT= 1.83	N=89 / RT=1.69	N=20 / RT=2.17	N=20 / RT=3.10	N=213 / RT = 1.92
Females	N=45 / RT= 2.00	N=87 / RT=2.13	N=9 / RT= 2.70	N=19 / RT=2.83	N=160 / RT = 2.21
Total	N=129 / RT=1.89	N=176 / RT=1.91	N=29 / RT=2.33	N=39 / RT=2.96	N=373 / RT=2.04

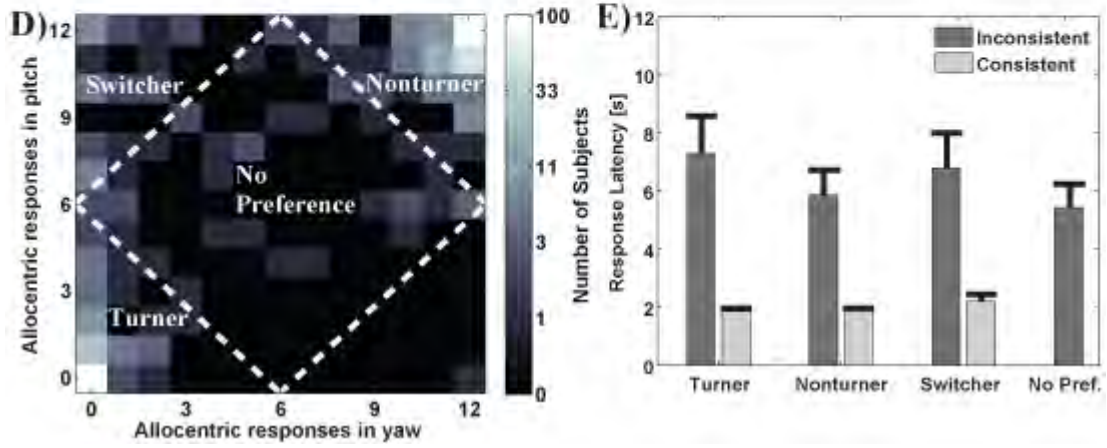
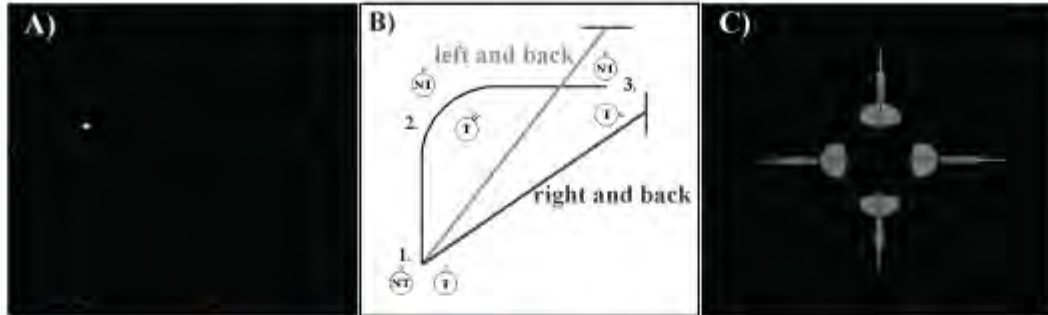

Brain tumor volume as a reliable predictor for overall glioblastoma patients survival – a epidemiological approach

Katharina Sofia Friedlein

¹Universitätsklinikum Erlangen-Nürnberg, Neurooncological laboratory, Vierzigmannstraße 15, 91054 Erlangen, Germany

Nic E. Savaskan¹, Michael Buchfelder and
Ilker Y. Eyüpoglu

Gliomas are primary brain tumors and account for almost 80 % of all diagnosed malignant brain tumors. Despite advanced treatment options gliomas and in particular glioblastomas (WHO IV) are still associated with very poor survival. Since primary surgery still presents the front line in the current management of glioma therapy it is important to define, whether preoperative tumor volume has any impact on patients' progression free survival and overall survival.

To tackle this issue we underwent an epidemiology study comprises 329 patients (158 women, 171 men; median age: 58.8 years) with histologically confirmed high-grade gliomas (296 patients with glioblastomas, 19 with astrocytomas, 8 with mixed gliomas, 3 with oligodendrogliomas, and 3 with other malignant brain tumors). All patients were treated from 2000 to 2011 at our department and tumor volumes were determined on preoperative and postoperative MR images. In anticipation of a short survival for patients with large tumor volume (35,0-200 ml) the overall survival of patients with glioblastomas was investigated. Median overall survival for these patients was 393 days. Patients with a small tumor volume (small sized tumors [SS-tumors] 0,0 - 12,9 ml) (n=90) survived 382 ± 327 days, 104 persons with a big volume (big size tumors [BS tumors] 35,0-200 ml) 374 ± 302 days. Whereas the group of patients with a mean tumor volume (middle size tumors [MS-tumors] 13,0-34,9 ml) had an overall survival of 432 ± 314 days. Our data indicate that patients with middle sized tumors could have an advance referring to overall survival time. In the next step we will further analysis whether the functional localization of tumors and age distribution have an impact on the tumor volume-survival analysis. In conclusion our results give first indications that volumetric parameters can have an impact on the prognosis of glioblastoma patients and may give also indications for subsequent glioma therapy.

Pharmacological evaluation of the efficacy of Tricaine (MS-222) as an anesthetic agent for blocking sensory-motor responses in *Xenopus laevis*

Carlana Ramlochansingh, Francisco Branoner¹, Werner Graf², Hans Straka¹

¹Ludwig-Maximilians-Universität München, Division of Neurobiology, Department Biology II, Großhardener Str. 2, 82152 Planegg, Germany

²Department of Physiology and Biophysics, Howard University, 520 W Street NW, Washington DC 20059

Anesthetics have been identified as agents that remove sensation through their ability to suppress nerve transmission, relieve pain and decrease body movements by skeletal muscle relaxation. Whereas, paralytic agents specifically block synaptic transmission at the neuromuscular junction, effectively paralyzing skeletal muscles without diminishing sensory inputs or motor outputs. Tricaine (MS-222) is considered as the standard anesthetic that is commonly used in experimentation on poikilothermic animals such as fish and amphibians. However, there is debate about the mechanistic action of MS-222 on sensory processing at the systems level. Thus, better knowledge concerning the influence on sensory processing is necessary to evaluate the potency, timing and recovery from the anesthetic action. Here, we studied by quantifying the anesthetic efficacy of MS-222 on sensory-motor transformation underlying gaze stabilization and the generation of compensatory eye movements during body motion in isolated, semi-intact *in vitro* preparations of *Xenopus laevis*. Effects of bath-administrated MS-222 at various concentrations (0.005%, 0.01% and 0.05%) were compared with various concentrations of an established anesthetic - benzocaine - and a known paralytic - pancuronium. *In vitro* electrophysiological recordings of the extraocular motor discharge during natural sinusoidal head rotation were measured before, during and after administration of MS-222, benzocaine and pancuronium and changes in discharge patterns were evaluated and quantified. Both MS-222 and benzocaine showed a significant decrease or complete inhibition, depending on the concentration of the extraocular motor discharge, which was not achieved with pancuronium. Moreover, there was a dose-dependency for the recovery time of neuronal firing as the lowest concentration returned to normal firing fastest. MS-222 also blocks the activity of vestibular nerve afferent fibers in a dose-dependent manner, which indicates that the mechanistic action of this anesthetic is similar to that of the traditional anesthetic benzocaine. Since MS-222 can block both sensory and motorneuronal activity, this caine-derivative represents as effective an anesthetic as benzocaine.

Self Motion from Optic Flow Monitored by Optical Mouse Chips

Hansjürgen Dahmen, Hanspeter A. Mallot¹

¹Uni Tübingen, Kognitive Neurowissenschaften, Auf der Morgenstelle 28, D-72076 Tübingen, Germany

Background: Many animals use landmarks and optic flow induced by their self motion to control their position and orientation in space: For short time intervals, self-motion can be decomposed uniquely into a pure rotational and a translational component. The 3D structure of the environment can then be extracted from the translatory component of optic flow. The decomposition of rotatory and translatory components is facilitated by large fields of view, in particular in cases where no other sensory systems like gyroscopes are available. In flies it has been shown that the distribution of motion sensitivity of single wide field neurons can be described as matched filters to extract specific self-motion components from the panoramic optic flow field. **Purpose:** We demonstrate that in a technical system moving on flat ground optic flow monitored by eight optical mouse chips can serve to extract both self-motion components. **Device:** Each sensor comprises a field of view of just 0.044 sr. The sensors are mounted on a sensor head and their viewing axes are distributed with 45° of azimuth relative to each other and look down at -45° elevation with respect to the horizon. The sensor head is mounted on a carriage (Fig a) which limits self-motion to two degrees of freedom: yaw and translation along the long axis. The sensors' response to self-motion induced flow is sampled at 50 frames/sec. **Algorithm:** Yaw and translation of the sensor head between two frames are extracted from the flow response of the eight sensors by applying a matched filter. The upper row of Fig c shows the matched filter for extracting 1 cm of translation from the eight sensors, the lower row represents the filter for extracting 1° of clockwise yaw. The filter responses have been evaluated by moving the sensor head along well defined pieces of yaw and translation. **Results:** The path of the carriage is reconstructed by integrating the yaw- and translation responses Fig b shows the reconstruction of a path that starts and ends at the same position in space. The error in path integration shows up in a deviation between the starting and end position of the track.

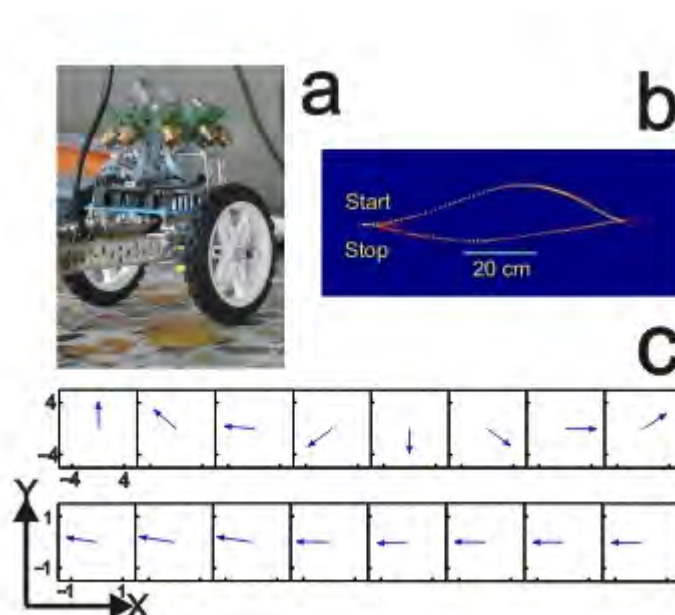

Author Index

A B C D E F G H I J K L M N O P Q R S T U V W X Y Z

- Abel, T T20-3A
 Abu , F T19-8D
 Ache, JM S22-7
 Ackels, T T19-4C, T19-17C
 Ackermann, PJ T22-3C
 Adam, R T24-7A
 Adameyko , II T4-2A
 Adelsberger, H T9-1D
 Adjaye, J T1-6A
 Aertsen, A T24-3A
 Afify, A T19-14B
 Afsari, Z T16-1A
 Afthinos, M T16-6D
 Agudelo-Toro, A S4-6
 Ahlf, S T18-5A, T18-9B
 Ahmad, F S19-3
 Ahmed, S T7-2D
 Ahnelt, P T15-5C
 Ahrens, S T13-3A
 Ahuja, G T19-17B
 Akad, SD T7-2B
 Akula, AK T7-2D
 Alaburda, A T23-5A
 Alam, M T11-9C
 Alberghina, L T9-2C
 Albers, C T26-9B
 Albrecht, A T13-3D
 Alenina, N S11-2, S11-7, T13-6A
 Alfaro Sanchis, JF T4-1D
 Al-Moyed, H S6-2, T17-2D
 Alonso, J-M T16-5D
 Alpár, A T6-5C
 Alt, MD T9-3A
 Altenhein, B T1-4C
 Altenhein, TK T1-4C
 Altmüller, J T19-14A, T19-9B, T19-11B
 Alttoa, A T13-4C
 Alvarez-Baron, E T15-2A
 Ammer, J S9-7, T18-5C, T18-8C
 Ammersdoerfer, S T10-3D
 Andersen, M T16-9B
 Andrade, M T7-6A
 Andreadaki, A T12-2D
 Andres-Alonso, M T7-10D
 Andreska, T T7-8C
 Andrews, D T22-2A
 Andrews, JC S8-1
 Anemüller, J T26-5C
 Angelov, SD T13-6B
 Annamneedi, A T7-4D
 Antemann, V T23-6A
 Antileo Ibarra, E T2-5C
 Antolin-Fontes, B T6-3A
 Antonucci, F T6-5C
 Appel, M S10-6, T25-1A
 Araya-Callís, C T12-5D
 Arendt, A T14-2D
 Arendt, T T18-9A
 Argento, A T2-4D
 Arnal, LH S15-4
 Arndt-Jovin, DJ T1-1D
 Arne, O T2-6B
 Arnold, C T19-14D
 Arp, M T22-3A
 Asan, E T4-3A, T13-1D
 Aschauer, DF T27-5C
 Asede, D T25-14C
 Ashti Baghaei, K T19-16C
 Astorga, G T8-3D
 Atorf, J T15-2A, T15-3A
 Auburger, G T11-5C
 Auer, S T6-3A
 Aufmkolk, S T7-8C
 Auge, E S6-2, T7-7D, T17-2B
 Augustin, MS T10-4D
 Avison, DL T3-3B
 Avraham, KB T2-6D
 Ayala, YA T18-3A
 Azorin, JM T13-4A

Author Index

A B C D E F G H I J K L M N O P Q R S T U V W X Y Z

- Babai, N S7-5
 Bach, D S1-5
 Bachmann, C T11-13D
 Backhaus, WGK T15-4D
 Badde, S S15-5
 Baden, T S2-3, T15-2B, T15-4B, T15-5B
 Bader, A T19-11C
 Bader, M S11-7
 Badowska, D T10-4C, T25-3A
 Bähr, M T3-1C, T11-1A, T11-7B, T11-10C, T11-6D, T11-11D, T12-4A, T23-8C, T24-6A
 Bakker, R T26-10D
 Baldridge, WH T15-8A
 Baldus, M T1-1A
 Ball, T T24-3A
 Balog, J T16-7B
 Baloni, S T24-11A, T24-1B
 Bamberger, P T11-13D
 Banchi, R T21-7C, T27-1C
 Bao, J T8-3D
 Baranovic, J T6-5D
 Bardos, V T19-2A, T19-5B
 Barnerssoi, M T21-9A
 Barria, A T18-1A
 Barros, LF T9-4A
 Barski, L T11-7B
 Bartelheimer, K T16-7C
 Bartels, R T25-13C
 Bartenstein, S T18-5B
 Barth, J T25-16B
 Bartos, M T7-5C, T8-2B, T13-4B
 Bartsch, M T16-4B
 Bartz-Schmidt, KU T12-1A, T12-2A
 Bas Orth, C T8-2D
 Basak, N T11-5C
 Baschwitz, AEE T19-3C, T19-8D
 Bass, AH T21-6C
 Bastin, F T19-6D, T25-10C
 Bathellier, B S6-5, T27-2C
 Batsching, SJ T25-9D
 Battaglia, D T23-2D, T26-3B
 Battaglia, FP S3-4
 Battas, O T13-4A
 Bauer, M S1-5
 Bäuerle, P T23-8A
 Bauermeister, C T26-7D
 Baumann, A T19-8B
 Baumann, O T5-2A
 Baumgart, S T19-8C, T19-9C
 Baumgartner, W T19-8A
 Baumgärtner, W T9-3B, T9-4D
 Bautze, V T19-3B
 Bavelier, D S5-4
 Bayley, TG T17-4B
 Baz, E-S T23-5C
 Bazhenov, M T8-1A
 Bebensee, D T10-2C
 Becherer, U T20-3C
 Beck, H T7-10C
 Becker, C T19-9B
 Becker, N T13-5A
 Becker, S T15-9B
 Becker, T T24-1C
 Bedner, P T1-3C
 Beesley, PW T10-2A
 Beetz, JM T14-2B
 Behr, J T13-3D
 Behrens, P T15-2B
 Beis, D S11-7, T13-6A
 Bekemeier, HH S22-6
 Belgardt, BF T22-2C
 Beltran, LR T19-7B
 Ben Abdallah, N T11-11B
 Benali, A T23-8D
 BENARDAIS, K T9-2D
 Benda, J S9-7, T17-5D, T26-1A
 Benndorf, K S18-2
 Bennegger, W T1-5D
 Benninger, F T6-1C
 Ben-Shahar, O T24-11D
 Berendes, V T21-3B
 Berens, P S2-3
 Berg, E S22-4
 Bergmann, J S10-2, S10-3, T25-1A
 Bergmann, U T26-2B
 Berner, S T4-2D, T18-6C
 Bernuth, Hv T10-1B
 Berron, D T25-15C

Berta, G T7-11C
Bertam, B T1-7D
Berthé, RA T21-1D
Bessaih, T T20-3A
Bethge, M S2-3, T15-2B
Betkiewicz, R T19-19C
Betz, H T7-9B
Betz, SF T18-1B
Beuter, L-K T17-1C
Beyer, KM T23-1B
Beyer, T T6-6A
Bhattacharya, S T10-2A
Bianco, MR T9-2C
Biber, K S17-4
Bicker, G T2-1B, T9-3B, T9-5B
Bickmeyer, U T27-6B
Biel, M T27-4A
Biergans, S T19-10A
Biermann, B T27-7B
Bikbaev, A T4-1D
Bikson, M S4-3
Bilz, F T23-6A
Binder, N T24-2C
Bintig, W T19-9C
Binzer, M T19-12D
Birchmeier, C T20-1B
Birchmeier, W T2-2D
Birkenhäger, R T18-10C
Birman, S T19-4D
Bischof, H-J T27-5A
Biskup, C S18-2
Biswas, S T11-5B
Bittsansky, M T13-2C
Bitzenhofer, SH T23-2A
Blaesse, P S19-2, S19-3
Blak, M T12-1A, T12-2A
Blank, S T18-6C
Blankenburg, S T5-2B
Bläsius, K S12-3
Blasko, J T19-18D
Blatt, I T5-1A
Bleckmann, H S9-4, T17-3D, T20-1A
Bleich, S T13-5B
Blenau, W S8-6, T5-2B
Blosa, M T18-9A
Blum, R T7-8C, T27-6A
Blumenthal, F T21-7A
Bock, HH T9-1C
Bock, J T25-9C
Bockemühl, T T21-5D
Böckers, T T11-1B
Bockhorst, T T14-1C
Böckmann-Barthel, M T18-4C
Bockstaller, M S10-6
Boeckers, TM T11-10A
Boehm, U T19-15C
Boekhoff, I T19-15C
Boggio, EM S5-5
Bola, M T13-6C
Bolasco, G S17-2
Boll, D T27-2A
Bollmann, JH T15-5D
Bolz, J T3-2D
Bonnard, O T19-5D
Bonny, C T11-12B
Booker, SA T5-1B
Borchert, J T11-3A
Bordet, T T11-4C
Borgelt, C T26-1D
Borgmann, A T21-2B, T23-2B
Bormuth, I T1-6C, T1-4D, T2-5B
Borovecki, F T11-8A
Borth, H T19-15C
Bosch, D T25-1C, T25-14C, T25-1D
Bost, A T20-3C
Both, M T7-10C, T23-1B, T23-9B, T23-9C
Bothe, L T25-1B
Boucsein, C S9-7
Boumil, RM T7-1B
Bourane, S T20-1B
Boussaoud, D T13-4A
Bradke, F T9-5C
Bradley, J T8-3D
Bradley, SA T21-8D
Branco, T T7-10A
Brandstaetter, AS T19-6D, T25-10C
Brandstätter, JH T15-2A, T15-3A, T15-4A
Brandt, AU T12-5A
Brandt, C T11-3C, T11-13C, T13-5B
Brandt, N T17-2A
Brandt, SA S4-4
Branoner, F T17-4C, T27-5D
Bräuer, AU T6-8B
Braun, HA T6-2B
Braun, J T16-4B, T26-4B, T26-7D
Braun, J-M T23-3D
Braun, K T11-8C, T25-6C, T25-9C
Braun, S T24-2D
Breer, H T19-13A, T19-15A, T19-3B, T19-15B, T19-21B, T19-2C, T19-5C, T19-11C, T19-21C
Brehm, N T11-5C
Breit, A T19-15C
Brembs, B T25-16C
Bremmer, F T16-4A, T16-7C
Bresenitz, P T6-4A
Brigadski, T T7-1C, T11-11C
Brill, MF T19-1A, T26-12B

Brill, S T18-9C
Bringmann, A S23-1
Brito, M T27-1D
Brochier, T S24-2
Brockhaus-Dumke, A T26-2C
Brockmann, A T19-6B
Brockmann, M T2-4B
Brodski, A T24-5B
Broggini, T T11-12A
Broich, K T6-3B, T17-5B, T23-6C, T23-7C, T25-4D
Bröking, K S9-6
Brönneke, HS T22-2C, T22-3C
Bronson, RT T3-3B
Brook, G T3-2A
Brosch, M T18-7B
Broschier, T T21-3D
Brose, N S7-4, T7-9B
Brosig, H T11-11A
Brötzner, C T24-7D
Brück, W T12-1C
Brunhofer, G T11-13C
Brüning, JC T22-2C, T22-3C
Brunne, B T9-1C
Brzózka, MM T10-4C, T13-1B, T25-3A
Büchel, C T25-12C
Buchfelder, M T1-4B, T11-12A
Buchholz, VN S15-2
Buchser, WJ T3-3B
Buckemüller, C T25-12A
Bucks, S T19-20C
Budde, T T23-9A
Buddrus, K T9-6B, T9-4C
Budinger, E T18-7B, T18-3D, T18-4D
Budziszewski, C T26-2A
Bueschges, A T21-2B, T21-2C
Buhl, E T23-4A
Bukowiecki, R T1-6A
Bulavina, L T9-2B
Bülles, K T18-7C
Büning, H T22-3C
Burgess, N S3-6
Burkhardt, H T1-2B
Burtscher, V T6-1B
Busch, R T1-1A
Büschges, A S22-3, S22-4, T21-2A, T21-8A, T21-1B, T21-3B, T21-7B, T21-4C, T21-5D, T27-4C
Busse, L T16-8A
Bustos, AE T1-4C
Bywalez, WG T19-18A

Author Index

A B C D E F G H I J K L M N O P Q R S T U V W X Y Z

- Cabral, Y T23-7B
 Cainarca, S T19-8A
 Caliskan, G T11-12D
 Cambridge, S T7-10C, T9-5C, T27-3A
 Campanelli, D T8-7C
 Camunas Mesa, LA T21-8D
 Cang, J S5-2
 Canopoli, A T21-9C
 Cantera, R T19-14D
 Cao, Y T19-10C
 Carcaud, J S13-5, T19-13D
 Carlsen, F T26-6D
 Carroll, P T20-1B
 Carson, M S17-3
 Casola, C T15-9B
 Caspari, N T16-5B
 Caspers, BA T19-3D
 Castiblanco, LL T25-8A
 Castilho, A S2-5
 Castillo-Padilla, DV T16-8B
 Castro, L T27-1D
 Castro, LR T5-1D
 Cavaliere, C T5-1A, T9-2C
 Cepeda, EA T8-7D
 Cerina, M T23-9A
 Certel, SJ S8-1
 Chaffiol, A T19-19D
 Chagnaud, BP T21-6C, T21-7C
 Chai, X T1-3A, T10-2D
 Chakrabarty, K T11-2D
 Chakrapani, B T1-9A, T1-1B
 Chaleshtori, MH T17-4D
 Challagundla, M T3-1C
 Chambers, CD T16-2D
 Chanda, B S18-3
 Chandrasekaran, S T16-3C
 Chang, C-H T11-9D
 Chang, L T15-4B
 Chang, S T7-3B
 Channappa, L T11-8D
 Chao, OY T3-3B
 Chapman, J T5-1A
 Chapochnikov, NM T7-7D
 Chatterjee, M T8-5B
 Chazeau, A T2-4D
 Chebli, M T6-5D
 Chen, G S19-6
 Chen, JT-C T8-7C
 Chen, J-Y T8-1A
 Chen, R T6-7C, T10-4A
 Chen, S T6-1C
 Chen, W T10-1B
 Chen, X T7-5A, T9-1D
 Chen Ngwa, E T21-1C
 Cheng, S S3-2, S3-3
 Chenkov, N T26-7A
 Cheret, C T20-1B
 Chesselet, M-F T11-4C
 Chhabra, R T11-10A
 Chistyakova, M T8-1A
 Chiu, W-H T11-12C
 Cho, S T7-5B
 Choquet, D S21-1
 Christ, P T19-7D
 Chronowska, E T11-12D
 Cichy, A T19-8A, T19-13B
 Cirillo, G T9-2C
 Claes, C T17-4D
 Claussen, JC T26-13D
 Clemens, J T17-1D
 Cohen, L T19-16D
 Colangelo, A T9-2C
 Contreras, D T20-3A
 Cooke, R T21-8D
 Coolen, A T22-2D
 Cooper, B S7-4
 Coppola, DM T16-4C
 Coppola, G T11-4C
 Corazza, S T19-8A
 Cordell, R T12-5B
 Correard, N T13-4A
 Coucke, P T17-4D
 Coulon, P T23-7A, T23-9A
 Courtin, J T25-11A
 Couto, A T19-5D
 Couton, L S22-2
 Craul, M T10-3D
 Crombach, S T19-9D

Crowley, J T16-3C
Croyé, M-A T25-15D
Cruces-Solis, H T16-7A, T18-4A
Crux, S T13-3C
Csicsvari, J S24-5
Cullen, D T24-4C
Cynis, H T11-6C
Czéh, B T11-4D
Czondor, K S21-1, T2-4D

Author Index

A B C D E F G H I J K L M N O P Q R S T U V W X Y Z

- Dahmen, H T27-6D
 DAmelio, PB T25-9B
 Dasgupta, S T25-7D
 Daumke, O T6-5D
 Davison, AP S24-3
 Davydova, D S7-6
 de Bruyne, M T19-17A
 De Camilli, P T7-1B
 de Graaf, E T12-4B
 de Hoz, L T18-4A
 de Hoz Garcia-Bellido, L T9-6D
 De Prins, E T8-3A
 de Visser, A T1-4C
 de Wit, H S7-2
 de Wit, N T19-18B
 Dean, C S20-7, T7-2D
 Deca, D T16-1D
 Dechent, P T16-1C, T23-8C, T27-1A
 Deckert, J T11-3B
 Deco, G T26-7D
 Dedek, K T15-1A, T15-4C
 Degen, J T25-2A
 Dehnicke, C T6-8B
 Deichman, R T16-1B
 Deisseroth, K P4
 Deisz, RA T6-8B
 Deitmer, JW T9-1A, T9-3A, T9-4A, T9-4C, T9-6C
 Deliano, M T25-8A
 Deller, T T8-2D, T8-4D
 Delvendahl, I T7-9A
 Demond, M T19-11B
 Dempewolf, S T25-5D
 Dempsey, C T16-5C
 Demuth, H-U T11-6B, T11-6C
 Denisova, NP T23-3C
 Denker, M S24-2, T21-3D, T26-1D
 Depboylu, C T11-12C
 Depner, H T7-11A
 Depner, M T18-3C
 Deregnaucourt, S T25-8B
 Derix, J T24-3A
 Derst, C T23-6B
 Dheedene, A T17-4D
 Dick, B T12-2B, T12-4D, T15-9B
 Dick, HB T12-4C
 Diegelmann, S S22-2, T25-1A, T25-2D
 Diekmann, H T12-2D
 Diepenbrock, J-P T18-2A, T26-5C
 Diesmann, M T26-7B, T26-8B, T26-11C, T26-12C, T26-10D
 Diester, I P4
 Dieterich, DC S20-5, T2-5C, T8-4C, T27-3C
 Dietrich, H T17-3C
 Dietrich, J T1-4C
 Dietrich, MO T22-2C
 Dippel, S T19-9D
 Dipt, S T25-16B
 Direnberger, S T27-1C
 Dirks, A T7-11D
 Dirnagl, U T12-5B, T22-2A
 Dischinger, U T13-4C
 Distler, C T15-7A
 Dittrich, L T22-1C
 Dittrich, M S10-6
 Dityatev, A T2-3A, T7-3A, T23-4D
 Djuric, D T11-7D
 Długaiczek, J T17-2A, T18-12D
 Dobrota, D T11-13B, T13-2B, T13-2C
 Dobrowolski, R T1-3C
 Doengi, M T9-4C
 Doepfner, TR T12-1B
 Doerr, C T27-4B
 Dokter, M T1-1A
 Dolan, RJ S1-5
 Domínguez Vargas, AU T24-2A
 Dondzillo, A T7-4C
 Dong, Y T13-5D
 Donkels, C T10-4D
 Donoso, JR T23-5D
 Doppelmayr, M T24-7D
 Dorfi, T T12-2A
 Dorgau, B T15-4C
 Döring, F T6-8D
 Dörr, J-M T12-5A
 Dosa, Z T6-5B
 Draguhn, A T7-10C, T23-1B, T23-9B, T23-9C
 Drakew, A T27-2B

Dresbach, T T7-7C, T7-1D, T7-2D, T7-5D
Dreykluft, A T11-2B, T11-2B
Driver, J S1-5
Dübbert, M T15-5A, T21-3B, T21-5D
Dubos, A T27-3A
Duch, C S22-1, T2-6C, T21-2D
Dudek, S T7-2A
Dugladze, T T11-12D, T23-8A
Dumas, L S17-2
Dürr, V S22-6, S22-7, T20-2D, T21-6D
Düzel, E T25-15C
Dwarakanath, A S15-6
Dweck, H T19-11D
Dyachuk, VA T2-1A
Dylda, E S9-4, T17-3D
Dylla, K T19-2D

Author Index

A B C D E F G H I J K L M N O P Q R S T U V W X Y Z

Ebbingshaus-Kintscher, U T21-2A
Eberhard, M T26-3C
Eberle, J T19-15A
Eckenstaler, R T7-1C
Eckhardt, M T11-9D
Eckmeier, D T19-12B
Edelmann, E T8-1C, T8-6D, T8-7D
Efetova, M S13-2
Egert, U S3-5
Egger, V T8-5B, T19-18A
Egorov, AV T7-10C, T23-1B
Ehrenreich, H T12-6A
Ehret, G T18-1C
Ehrhardt, E T15-6B
Ehrlich, I T25-1C, T25-14C, T25-1D
Eichele, G T15-6C
Eickhoff, R T2-1B
Eilers, J T7-9A
Einevoll, GT T26-5D
Einhäuser, W T16-9B, T26-9D
Eipert, P T26-8D
Eirich, K T10-1B
Eisbach, SE T11-1D
Eiselt, A-K T24-3D
Eisenhardt, D T25-10A, T25-12A, T25-1B, T25-3C
Eisenhardt, G T7-4C
Eisenschmidt, E T25-5C
Ekberg, JA T9-4C
Ekstroem, P T11-2C
El Hady, A S9-6
el Jundi, B T14-2B
El Muayed, M S19-2
Elfving, B T6-5B
Elger, CE T27-2A
Elger, DA T11-3D
Elissalde, S-N T13-4A
Emmanouilidou, E S14-4
Endres, D T26-6B
Endres, DM T24-7A
Endres, T T11-9B, T11-8C, T25-12B
Engel, AK T15-7D, T23-4D
Engel, J S6-6, T17-2A
Engelen, J T21-4A
Engelhard, K T12-3D
Engelhardt, M T2-1D, T7-10C
Engelken, R T23-9D
Engelmann, P T3-1D
Engler, G T15-7D, T23-4D
Eppler, JM T26-8B
Erdmann, F T7-4B
Erdmann, J T21-10C
Ergül, N T2-1D
Eriksson, D T16-3B
Erisken, S T16-8A
Erker, T T11-13C
Ernst, U T26-5B
Ernst, UA S24-6, T26-6C
Esser, K-H T18-5D, T25-4B
Estebanez, L T21-3C
Euler, T S2-1, S2-3, T11-4B, T15-2B, T15-5B
Euteneuer, S T13-2D
Evans, P S8-1
Everling, S T23-7D
Evers, JF S22-2
Evers, N T22-3C
Evinova, A T13-2B
Eysel, UT T16-9D
Eyüpoglu, IY T1-4B, T11-12A

Author Index

A B C D E F G H I J K L M N O P Q R S T U V W X Y Z

- Fabianova, K T19-18D
 Faelber, K T6-5D
 Faghihi, F T19-3A
 Fairhall, AL S9-3
 Falibene, A T19-1C
 Falkai, P T10-4C, T25-3A
 Falomir Lockhart, LJ T1-1D
 Falsone, SF T11-5D
 Fan, E T11-4B
 Fan, L T10-2D
 Fan, Z T1-4B, T11-12A
 Faraci, F T26-11A
 Farina, D T23-6D
 Farkhooi, F T19-19C, T26-9C
 Farzana, F T7-10B
 Faust, L T25-5A
 Fauth, M T25-13B
 Favaro, PdN T8-8B
 Fazeli, S T16-1C
 Fecher, C T27-6A
 Fedorov, A T13-6C
 Fedun, J T11-12D
 Fehlert, M T19-11A
 Feige, JM T21-1C
 Feigenspan, A T15-3A, T15-8C
 Feit, PW T11-13C
 Fejtova, A S7-6, T7-10D, T7-11D
 Fejtová, A T7-4D
 Feldmeyer, D T2-4A, T7-8A, T7-11B, T20-3A
 Fell, B T17-2A
 Felmy, F T18-10B, T18-5C, T18-6C, T18-8C, T18-1D, T27-1C
 Felsenberg, J T25-3C
 Fendt, M T24-5C
 Ferger, R T18-12A
 Ferilli, M S4-5
 Fernandez, E T15-5C
 Fernández, MP S8-1
 Ferraguti, F T25-14C
 Ferrarese, L T6-3A
 Ferreira, J T11-8A
 Ferreira, T S17-2
 Fetani, AF T11-8B
 Fiala, A T19-4D, T22-1B, T25-16B, T25-5D
 Fiehler, K S15-3
 Filippov, M T7-3A
 Filkin, S T6-3A
 Finger, H T23-5B
 Fink, C T27-6B
 Finsterbusch, K T12-2C
 Firzlaff, U T18-4B, T18-5B, T18-8B, T18-8D
 Fischer, A T7-6D
 Fischer, D T12-2D
 Fischer, J T25-9A, T25-2C
 Fischer, K-D T12-1D
 Fleck, D T11-7C
 Fleck, S T25-12C
 Flegel, C T19-9A, T19-14A
 Fleidervish, I T26-6A, T26-8C
 Fleischer, J T19-5C
 Fleming, SM T11-4C
 Fleming Outeiro, T T11-6A, T11-1D
 Fletcher, M T19-10C
 Flindt, N T26-4D
 Flood, Z T7-5B
 Flórez Weidinger, JD S5-3
 Fluegge, D T19-8A
 Flügge, G T12-5D
 Flurer, JM T1-1B
 Folta-Schoofs, K T24-9B
 Folz, J T25-16D
 Fonseca, L T11-8A
 Fontaine, J-F T6-3A
 Fontinha, B T27-2C
 Fontinha, BdPP S6-5
 Förster, E T2-2C
 Förster, J T21-2A
 Förster, R T9-1D
 Frahm, J T8-5D
 Frahm, S T6-3A
 Franck, MWE T8-1C
 Franco, S T1-8B
 Frank, S T19-9D
 Frank, T T7-6B
 Franke, F T9-2D
 Franke, H T2-2B
 Franke, K T15-5B, T25-15A
 Frankel, WN T7-1B

Fransen, E T17-4D
Franz, C T18-12D
Franzen, D T18-6C
Franzen, F T16-8A
Frech, MJ T1-5C
Fregni, F S4-7
Freing, A T12-5A
Freitag, C T27-3C
Frerix, S T1-9A
Friauf, E T7-6D, T8-1B, T9-3D, T10-5B
Friedlein, KS T27-4D
Friedman, A S20-6
Friedrich, K T6-6B
Frieling, H T13-5B
Frischknecht, R S21-1, T4-1D, T6-1A, T7-3C, T8-2A, T25-8A
Fritschy, J-M S19-1
Fröhler, S T10-1B
Frontczak-Baniewicz, M T9-3C
Froriep, UP S3-5
Frotscher, M S12-4, T1-3A, T9-1C, T10-2D, T27-2B
FU, Y S21-3
Fuchs, E T11-4D, T22-2D, T22-3D, T27-1A
Fuchs, M T15-4A
Fuhr, M T8-1B
Fuhrmann, F S19-5
Fuichs, T S19-6
Fukai, T T26-8B
Fukuda, A T6-7C
Funk, N T19-20A
Funke, K T16-8B, T20-2A, T23-8D
Fürst, C T12-1D
Fusca, D T19-8B

Author Index

A B C D E F G H I J K L M N O P Q R S T U V W X Y Z

- Gaab, S T19-18B
 Gabriel, JP T15-5D
 Gabriel, M T11-13C
 Gaese, BH T18-1B, T18-2B
 Gahr, M T18-11B, T25-7A, T25-8B
 Gail, A T16-2B, T21-8B, T21-9B, T21-8C, T26-2A
 Galindo-Leon, E T15-7D
 Galinski, S T25-4B
 Galizia, CG T19-10A, T19-19A, T19-10B, T19-2D, T25-8C, T27-2D
 Galizia, GC T19-14B, T19-1D
 Gall, C T13-6C
 Gampe, K T7-1A, T9-4B
 Gansel, K T27-1B
 Gao, F T11-4C
 Garaschuk, O T19-16D
 Garbers, C T14-3B, T16-8D
 Garcia, M S21-1, T2-4D
 Garcia-Pino, E T18-11C
 Garea-Rodríguez, E T11-4D, T27-1A
 Garnery, L S13-5
 Gass, P T1-1A, T13-6D
 Gasser, T P2
 Gavrillov, N T24-9D
 Gawalek, P T19-7A, T19-20A
 Gedrová, Š T21-9D
 Gee, AL T5-1B
 Gehring, KB T25-10A
 Geis, C T11-2B, T11-2B
 Geisel, T S9-6, T23-2D, T26-3A, T26-3B
 Geisler, H-S T18-12D
 Geißler, DB T18-1C
 Genc, E S10-3
 Genç, E S10-2
 Genç, Ö S7-3
 Georgieva, P T9-2B
 Gerber, B T25-1A, T25-15A, T25-2D
 Gerdes, AB T20-1D
 Gerhardt, E T11-5A
 Gerken, G T12-3A
 Gernert, M T11-3D
 Gerstein, G T26-1D
 Gey, L T11-3D
 Ghelani, T T7-7C
 Ghisi, V T6-5D
 Giang, TT T19-7C
 Giannone, G S21-1, T2-4D
 Giese, MA T24-7A, T26-6B
 Gieselmann, V T11-9D
 Giesert, F T11-10D
 Gilling, KE T13-3D
 Giraldez, T S18-4
 Gispert, S T11-5C
 Gisselmann, G T6-3C, T19-9A, T19-14A, T19-9B, T19-11B, T19-13C, T19-16C
 Gitler, D T7-7B
 Giurfa, M T19-13D
 Giustetto, M S17-2
 Giusti, S T2-4B
 Glasauer, S T16-6B
 Glebov, K T3-2B, T9-2A
 Gleiss, H T18-11A
 Gliem, S T19-15D
 Glocker, M T1-4A
 Gloveli, T T11-12D, T23-8A
 Gobrecht, P T12-2D
 Gödekdag, S S10-6
 Godenschweger, F T16-4D
 Godlewska, E T21-1B
 Goebbels, S T1-4D, T2-5B
 Goeckel, T T18-2D
 Goeke, CM T27-3D
 Goenner, L T26-1B
 Goepfert, M T18-2C
 Goetze, B T16-3A, T16-7A, T16-8C, T16-9C
 Goh, J T25-7C
 Goldammer, J T21-8A
 Goldschen-Ohm, M S18-3
 Goldschmidt, J T25-6C
 Gollisch, T T15-6B, T15-7B, T15-8B, T15-2C, T15-3C, T15-7C, T15-1D, T15-3D
 Göpfert, MC T17-5A, T20-2B
 Gordillo-Gonzalez, V T27-2A
 Górecki, DC T9-3C
 Gorin, M T19-8A, T19-16A
 Gorinski, N T2-3A
 Göthe, R T25-11B

Gotovac, K T11-8A
Gottlob, I T16-3D
Gottschalk, A T6-1D, T8-7B, T25-6D
Götz, M T19-18A, T19-16D
Gould, D T27-2A
Goulet, J T17-5C
Goyer, D T2-3D
Grabe, V T19-18C, T19-8D
Grabrucker, A T11-1B
Grabrucker, AM T11-10A
Graf, W T27-5D
Graf, YJ T25-16C
Grimann, B T23-3D
Gralle Botelho, M T1-1D
Gramann, K T27-3D
Gramlich, OW T12-4C
Grant, S T14-1B
Grass, A T24-2A
Grätsch, S T21-5A
Grauthoff, S T25-4C
Gravot, CM T18-11D
Greb, H T15-8A
Greene, G T15-6B
Greifzu, F S5-7, T16-7A
Grendel, J T6-2D
Grewe, J T26-1A
Griemsmann, S T1-3C
Grienberger, C T7-5A
Griesemer, D T7-6D
Grimes, WN S2-7, T7-3D
Grimpe, B T3-3B
Grishina, O T1-4D, T2-5B
Groc, L T6-1A
Groh, C T8-4B, T19-16B
Groh, KC T19-19B
Grosche, A S23-1, S23-2
Grosche, J T6-5C
Gross, CT S17-2
Groß, I T25-12A
Großer, E T10-5C
Grosse-Wilde, E T19-19B, T19-20C, T19-10D,
T19-11D, T19-17D
Grothe, B T4-2D, T18-11A, T18-10B, T18-8C,
T18-1D, T18-9D, T18-11D, T27-4A
Grothe, I S24-6
Grübel, K T8-4B, T19-16B
Gruber, D T13-3D
Gruen, S T26-1D
Gruender, S T6-4A
Gruenhage, G T26-9D
Gruhn, M S22-3, T21-4A, T21-1B, T21-2B, T21-3B
Grün, S S24-2, T19-10C, T21-3D
Gründer, S T6-6B
Grünewald, B T11-2B, T25-5A, T25-9A, T25-2C,
T25-11C
Grünewald, N T6-2A
Grus, FH T12-4C
Gruss, M T11-8C
Grytskyy, D T26-12C
Grzeschik, R T18-4C
Gudermann, T T19-15C
Gudi, V T9-2D
Guerreiro, P T11-5A
Guerreiro, PS S14-6
Guiducci, E S17-2
Guiot, E T27-1D
Gummert, M T1-4D
Gundelfinger, ED S7-6, T7-8B, T7-4D, T7-10D,
T7-11D, T8-2A, T10-2A, T12-1D, T25-5C
Gunszt, D T3-1D
Günter, RH T7-11B
Günther, V T15-6C
Gurniak, C S12-3
Guschlbauer, C T21-7B, T27-4C
Gustav, D T25-8C
Gütig, R T26-5A, T26-12A, T26-10B
Gutknecht, L T13-1D
Gutnick, MJ T23-8B, T26-6A, T26-8C, T26-11D
Gutsche, K T18-12D
Gutzmann, A T2-1D
Guzulaitis, R T23-5A

Author Index

A B C D E F G H I J K L M N O P Q R S T U V W X Y Z

- Haas, CA S3-5, T1-8A, T10-3A, T10-4D, T11-12D
 Haas, M T5-2D
 Haas, O T26-13A
 Haas, SJ-P T11-4A
 Haass, C T11-7C
 Haberkern, HJM T14-1A
 Hackelberg, S T5-3A
 Hackenbroich, C T18-5D
 Haenicke, J S13-4
 Haering, C T19-12C
 Hage, SR T24-10C, T24-9D
 Hagen, H T8-3B
 Hagos, Y T9-5A
 Hahn, J T25-5A
 Hahnloser, R T21-9C, T25-11D
 Haid, D T19-21B
 Hainmüller, T T8-2B
 Halfmann, M T24-8B
 Hallermann, S S7-1, T7-9A
 Halliday, G S14-6
 Hamad, MI T2-6B
 Hambach, B T23-6C
 Hamker, FH T26-1B
 Hammer, K T9-4B
 Hampel, B T22-3C
 Hampel, M T16-1A
 Han, K-A S8-1
 Han, Y S7-5
 Handreck, A T11-3D
 Handschuh, J T12-1D
 Hanganu-Opatz, IL T2-4A, T6-7C, T20-3D, T23-2A, T23-3A
 Hanisch, U-K S17-1, T12-1C
 Hans-Christian, P T6-8A
 Hansen, N T8-6A
 Hansmann-Roth, S T24-8B
 Hansson, BS T19-20A, T19-2B, T19-19B, T19-20B, T19-3C, T19-18C, T19-20C, T19-8D, T19-10D, T19-11D, T19-14D, T19-17D
 Happel, MFK T18-3D, T25-8A
 Hardiess, G T24-10B, T24-1C, T24-10D
 Harkany, T T6-5C
 Harnack, D T26-6C
 Harrach, D T1-1C
 Hartfil, S T4-3D
 Härtig, W T6-5C
 Hartlage-Rübsamen, M T11-6B, T11-6C
 Hartmann, A-M T2-6D, T6-6A
 Hartung, H T23-3A
 Hartveit, E S2-5
 Hartwich, H T2-6D
 Harzsch, S T19-11D
 Hasan, MR T12-1B
 Hasan, MT T13-6D
 Haselmann, H T11-2B, T11-2B
 Hassenklöver, T T2-3C, T19-6A
 Hatt, H T6-3C, T19-9A, T19-14A, T19-9B, T19-11B, T19-8C, T19-9C, T19-12C, T19-13C, T19-14C, T19-16C
 Hauber, W T24-1D, T24-2D
 Haus, UU T25-5C
 Häusler, U S3-5
 Häusser, M T7-10A
 Häussler, U T1-8A, T11-12D
 Haverkamp, S S2-6
 Hawlitschka, A T11-11A
 Haydon, P S23-2
 Hayoz, S T3-1B
 Hechavarria, JC T18-10A
 Heck, D T19-10C
 Hecker, D T17-2A, T18-12D
 Heckmann, C T11-4D
 Hedrich, J T12-3D
 Hedwig, B T14-1A, T17-4B, T23-4B, T23-1D
 Heed, T S15-5
 Heermann, S T1-6B
 Hefft, SM T10-4D
 Hegemann, P T8-7B
 Hegg, CC S23-6, T3-1B
 Heide, D T16-5C
 Heiden, M T18-9B
 Heidrich, S T1-6D
 Heil, P T17-1B
 Heiming, RS T25-4C
 Hein, K T12-4A
 Heindorff, K T5-2A
 Heine, C T2-2B

Heine, M S21-1, S21-5, T4-1D, T6-1A, T7-8B, T7-3C, T12-1D, T27-7B
Heinemann, U S20-6, T11-8B, T11-12D, T13-3D
Heinrich, R T12-6A
Heinze, S T14-2B
Heisenberg, M T24-1A, T24-4A, T25-8D, T25-9D
Helbling, S T24-5B
Helfmann, S T17-4D
Helias, M T24-3A, T26-8B, T26-11C, T26-12C
Hellbach, N T1-3D, T1-8D
Hellekes, K S22-3, T21-4C
Helms, G T11-4D, T27-1A
Helmy, M S19-2
Henke, J T16-8D
Henkel, B T19-4C, T19-17C
Henneberger, C S7-6
Hennig, RM T17-1D
Henninger, J T17-5D
Hennings, JC S19-2
Henrich-Noack, P T10-3B
Henschke, J T18-4D
Henseler, C T6-3B, T17-5B, T25-4D
Hensgen, R T23-4C
Herbik, A T15-6A
Herman, J T19-6B
Herman, M T7-7A
Hermann, DM T12-1B
Hermann, M T25-16B
Hermann, S T15-8A
Hermes, M T19-16D
Herpers, M T24-3A
Herrera-Molina, R T7-8B
Herrmann, C T19-9C
Herrmann, E T11-5C
Herrmann, JM T23-6D, T26-3A
Herrmann, M T18-6A
Herrmann, U T8-5A, T8-1D
Herry, C T25-11A
Hertzberg, T T27-2A
Herz, AV T27-5B
Herzel, H T26-9A
Hescheler, J T6-4D
Hess, BJ T21-1C
Hess, ME T21-10B, T22-2C
Hess, S T22-2C, T22-3C
Hesse, J T26-10A
Heuer, CM T4-1B, T19-6C, T19-12D
Heufelder, K T25-10A
Heumann, R T11-2D
Hick, M T8-1D
Hiemke, C T12-5D
Higgs, MH S9-5
Hildebrandt, H T1-2B, T1-5B
Hilgen, G T20-2C
Hillmann, J T26-10B
Himmelreich, S T25-11C
Himmelstoß, NA T25-4A
Hinchliffe, D T8-3C
Hindermann, M T19-7A
Hinrichs, H T13-6C
Hirnet, D S23-4
Hirrlinger, J T7-9A
Hirt, U T10-5C
Hitzmann, B T11-2C
Höber, J T7-5D
Höche, N T8-4C
Hock, SW T1-4B, T11-12A
Hodde, D T3-2A
Hoehl, D T27-4B
Hofbauer, B T27-6B
Hofer, S T8-5D
Hoffmann, A T24-2B
Hoffmann, K T22-2D
Hoffmann, K-P T15-7A
Hoffmann, MB T15-6A, T16-2D, T16-3D, T16-4D, T18-4C
Hoffmann, S T18-8B, T18-8D
Höffmann, J T27-2A
Höfling, C T11-6C
Hofmann, D T23-6D, T26-6A
Hofmann, H-D T1-9A, T1-1B
Hofmann, J T12-1A, T12-2A
Hofmann, UG T25-10D
Hollmann, C T7-11A
Holm, MM T6-5B
Holsboer, F T22-3A
Holt, M T7-11A
Holthoff, K T16-2C, T16-10C, T22-2B, T26-6D
Hölzl, GC T15-6A
Holzwarth, K T13-6A
Homberg, JR S11-4, S11-6
Homberg, U T14-1B, T14-2B, T14-1C
Homma, R T19-16D
Hoogenraad, C T12-4B
Hooper, SL T27-4C
Hopf, JM T16-4B
Hormuzdi, SG T15-4C
Horn, AK T21-9A, T21-1C
Horn, P T6-8B
Horschitz, S T1-7A
Horstmann, H T7-7B
Horstmann, L T12-4D
Horvath, TL T22-2C
Horváth, B T3-2C
hosy, e S18-5
Hougaard, KS T6-5B
Hounsgaard, J T23-5A
Housley, GD S23-3

Hövel, P T26-4A
Hoyer, N T15-8A
Hoyo Becerra, C T12-3A
Hricová, L T21-9D
Hrncic, D T11-7D
Hu, F S17-5
Hu, J T8-7C
Hua, Q T11-3B
Huang, JZ T13-3A
Huang, X T16-8C, T16-9C
Huang, Y S14-6
Huang, Y-Y T16-6D
Huang, Z T6-2D
Hübener, A T12-3A
Huber Brösamle, AB S16-2
Hübner, C T25-1D
Hübner, CA S19-2, T16-2C
Hübner, R T1-5C
Huebner, AK S19-2
Hueer, J T24-1B
Huerta, R S13-7
Hull, M T23-4A
Hulsenboom, E T12-4B
Hülsmann, S T9-5A
Hummel, J T17-6A
Hummel, T T19-9B, T19-13C
Hundsrücker, C S13-2
Hurtado, A T3-3B
Husarova, V T13-2C
Husch, A T19-8B
Hustert, R T21-5B
Hutch, C T3-1B
Hynie, S T5-2C

Author Index

A B C D E F G H I J K L M N O P Q R S T U V W X Y Z

Ibanez-Tallon, I T6-3A
Igarashi, J T26-8B
Ignatious Raja, JS T19-10B
Ihrke, M T26-12A
Ikegaya, Y S20-1
Ikenberg, B T8-2D
Ilin, V T26-1C
Illes, P T6-7B
Illing, R-B T18-10C, T18-10C
Imbrosci, B T6-4C, T7-4A
Imig, C S7-4
Inagaki, A T17-4D
Iqbal, T T3-1B
Iris, T T12-4C
Isbrandt, D T6-5A, T6-2D
Ishii, S T26-8B
Issa, L T1-2C, T1-7C, T10-1B
Isstas, M T3-2D
Ito, J T19-10C
Ivanova, D T7-11D
Ivanova, ON T5-1C
Ivanova, S T10-4D
Ivashkin, EG T4-2A

Author Index

A B C D E F G H I J K L M N O P Q R S T U V W X Y Z

Jacob, JP T23-1D
Jacob, SN T24-5D
Jaehde, P T18-2C
Jahn, A T8-6D
Jakoby, P T9-4A
Jalil, A T8-3D
Jan, H T17-2C
Janc, OA T10-5C
Jancke, D T16-9D
Jancke, L S10-7
Janova, H T12-1C
Jansen, F T19-9C
Jansen, M T16-5D
Jansen, RF T25-7A
Janssen-Bienhold, U T15-1A, T15-8A
Jaramillo, S T13-3A
Jastorff, J T16-5B
Jastroch, M T11-10D
Jaumann, M T10-4B, T17-6B
Jendryke, T T12-3C
Jensen, K T6-5B
Jensen, O S15-2
Jeschke, M T18-3D
Jessen, K T21-4D
Jia, C T3-1B
Jin, J T16-5D
Jin, N T25-10B
Jing, Z S6-3, T7-6B
Joachim, SC T12-2B, T12-4C, T12-4D, T15-9B
Jochner, MC T10-3C
Joels, M T22-3A
Joerk, A T22-2B
Johannes, S T17-2C
Johnson, SL T18-12D
Jois, SV T4-1C
Joly, M T10-3D
Jordan, J T7-7A, T26-7B
Jordan, SD T22-2C
Josens, R T19-1C
Jovin, TM T1-1D
Junca, P S13-5
Jung, S T7-1B
Jüngling, K T7-4B, T23-7A
Jungnickel, R T21-1A
Justus, D S19-5
Jüttner, R T2-2D

Author Index

A B C D E F G H I J K L M N O P Q R S T U V W X Y Z

- König, P T16-1A
 Kabat vel Job, K T25-9A
 Kacza, J T6-5C
 Kadas, D S22-1
 Kafitz, WK T9-1B
 Kagan, I T24-2A, T24-6A
 Kähne, T T2-5C, T8-4C, T25-5C, T27-3C
 Kahnt, J T19-12D
 Kaila, K S19-2, S19-3
 Kaindl, AM T1-2C, T1-7C, T10-1B
 Kalbe, B T19-8C, T19-9C
 Kaldenbach, F T20-1A
 Kalil, K S16-4
 Kalogeraki, E T15-6C, T16-2A
 Kaminiarz, A T16-7C
 Kaminstky, L S20-6
 Kamp, MA T6-4D
 Kanageswaran, N T19-11B
 Kanai, R S10-5
 Kaneko, H S19-5
 Kang, HJ S19-2
 Kanishkova, T T6-8A
 Kann, O T11-8B
 Kanowski, M T16-3D
 Kanyshkova, T T23-9A
 Kaping, D T23-7D, T24-11A
 Karakatsani, A T2-5A
 Karas, M T7-2A
 Karl, K T18-11C
 Karsai, G T7-11C
 Kasap, B T26-4C
 Kaschube, M S5-3, T16-4C
 Kasini, K T17-6B
 Kaspar, K T24-6C
 Kästner, SB T18-6D
 Katanaev, VL T19-10B
 Kätzel, D T23-1A
 Katzner, S T16-8A
 Kaule, FR T16-3D, T16-4D
 Kaupert, U T25-3B
 Kayser, C S15-6
 Keary, N T27-5A
 Kedar, GH S7-2
 Kehlen, A T11-6B
 Keil, P T17-2C
 Keil, W S5-3, T15-6D, T16-4C, T16-5C
 Kelber, C T19-16B
 Keller, D S7-5
 Keller, M T23-9B
 Kellner, C T18-6C, T26-13A, T27-5B
 Kellner, Y T8-7A
 Kelly, T T7-10C
 Kelly Pérez, I T16-6A
 Kemmler, R S2-1, T11-4B
 Kempter, R T23-5D, T26-7A, T26-2B
 Keplinger, S T27-4A
 Keramioti, M S14-4
 Kern, R T14-2C
 Kerr, JN P7
 Kerschbaum, HH T24-7D
 Kettenmann, H S17-5, T9-2B
 Kettler, L T18-9C
 Kettlitz, R T26-8D
 Keyser, J T25-12C
 Khabarova, MY T4-2A
 Khadimallah, I T8-8A
 Khani, MH T15-1D
 Kharchenko, OA T4-2A
 Kilb, W T2-4A, T6-7C, T10-4A
 Kilduff, TS T22-1C
 Kiliass, A S3-5
 Kim, S-G T16-3C
 Kind, PC T10-1A
 King, C S7-6
 Kiran Akula, A T7-5D
 Kirbach, A T25-2A
 Kirches, E T11-9B
 Kirilkin, I S19-2
 Kirischuk, S T10-4A
 Kirkerud, NH T25-8C
 Kirmse, K T16-2C, T16-10C, T26-6D
 Kirsch, M T1-9A, T1-1B
 Kirschmann, G T8-8A
 Kisucká, A T21-9D
 Kittel, Á T9-4B
 Klaes, C T16-2B
 Klagges, BRE T21-1A
 Klasen, K T19-8C

Kleber, J T25-2D
Klein, A S9-4, T17-3D, T19-2A, T19-5B
Klein, C T13-2A
Klein, J S13-6
Klein, S T20-2A
Kleineidam, CJ T19-17D, T20-3B
Klemann, M T19-2A
Klemen, J T16-2D
Klenerova, V T5-2C
Kletke, O T6-3C
Klietz, M T11-12C
Klimesch, W T24-7D, T25-4A
Klingenhoefer, S T16-4A
Klinner, C T19-10D
Klippenstein, V S18-6
Klohs, J T12-5B
Kloppenburg, P T19-2A, T19-11A, T19-5B, T19-8B, T21-8A, T22-2C, T22-3C
Klosterkötter, J T26-2C
Kluck, C T6-4B
Klücken, J S14-2
Kludt, E T19-15D
Klueva, J T27-7B
Kluge, C S1-5
Klünker, A-K T26-8D
Klussmann, E S13-2
Klyueva, Y T7-3C
Knaden, M T19-20B, T19-8D, T19-11D
Knezovic, A T11-3B
Knipper, M S6-4, T8-7C, T10-4B, T17-6B, T18-6B, T18-12D
Knoflach, D T15-5C
Knorr, AG T16-6B
Kobayashi, K T11-12C
Kobbenbring, S T22-1B
Kocabey, S S10-6
Koch, F T27-4A
Koch, J-C T3-1C, T11-1A
Koch, L T22-2C
Koch, S T19-17D
Kochlamazashvili, G T2-3A
Kochubey, O S7-3
Kocsis, JD T9-3B
Koenig, C T19-20C
Koenig, S T24-4A
Koester, RW S12-2
Kohl, J S21-5
Kohl, T T20-1A
Kohler, A S10-2, S10-3
Kohmann, D T23-7A
Koizumi, H T23-2B
Kolb, L T25-11D
Kolbaev, SN T6-7C, T10-4A
Kollert, S T6-8D, T25-4C
Kollmann, M T19-7D, T19-9D
Kolodziej, A T25-5C
Kolodziejski, C T19-3A, T26-10C
Komban, SJ T16-5D
König, C T19-10D
König, J T11-4D, T27-1A
König, P T16-1A, T23-5B, T24-6C, T25-12C, T27-3D
König, SU T24-6C, T25-12C
Königsrainer, A T19-15B
Könnecke, B T11-6D
Könner, C T22-3C
Konnerth, A T7-5A, T9-1D, T16-1D
Kononenko, DN T4-3D
Köpschall, I T18-12D
Körber, C T7-4C
Korkmaz, S T6-1B
Korotchenko, S T7-3A
Korotkova, T T23-3C
Korsching, SI T19-17B, T19-15D
Korte, M T2-6A, T8-4A, T8-5A, T8-7A, T8-2C, T8-5C, T8-1D, T9-6A
Körte, S T19-20A
Koschak, A T6-1B, T15-5C
Kössl, M T17-1A, T17-3A, T17-6A, T18-10A
Kotsiari, A T9-2D
Koutsoudaki, P T9-2D
Kovalchuk, Y T19-16D
Kowalczyk, S T11-12D
Kowalski, M T6-7B
Kozicz, T S11-4
Kozyrev, V T16-9D
Krabichler, Q T15-2D
Kraemer, N T1-2C, T10-1B
Kraftsik, R T8-8A
Krahe, R T17-5D
Kral, A T18-6D
Krala, M T19-6C
Kramer, M T19-15B
Krämer, N T1-7C
Kraus, E T13-4D
Krause, ET T19-3D
Krause, T S22-5
Krauss, JK T11-1C, T11-9C, T13-6B
Kravitz, EA S8-1
Krebbbers, J T6-2C
Kreissl, S T19-1D
Kreiter, AK S24-6, T27-2A
Kremer, H T17-4D
Kremers, J T15-2A, T15-3A
Kremkow, J T16-5D
Krempler, K S5-7, T16-2C
Kress, V T6-2A
Kretzberg, J T20-2C

Kretzschmar, B T12-4A
Kretzschmar, H T11-7B
Kreutzer, M T1-4A
Kreuz, S T27-5C
Kriebel, A T3-2A
Krieger, J T19-12A, T19-13A, T19-2C
Kriegelstein, K T1-2A, T1-6B, T1-2D, T11-4A, T12-3B
Kriener, B T26-5D
Krippner, M T17-5C
KRISHNA, S T16-7D
Krishnamoorthy, V T15-7B, T15-1D
Krizhanovskiy, S T13-5C
Kröcher, T T1-2B
Kroeger, A T12-2C
Kröger, S T2-5A
Kromer, T T26-8A
Kropf, J T19-5A
Kropf, S T25-5C
Krug, M T9-5D
Krüger, H-H T18-5D
Krüger, M T16-1A
Krugers, H T22-3A
Ku, M-C S17-5
Kucharíková, A T21-9D
Kuegler, S T11-11D
Kuehn, M T12-4C
Kuehn, S T12-4C
Kuenzel, T T2-3D
Kugler, C T6-1B
Kugler, K T18-9D
Kügler, R T17-2C
Kügler, S T3-1C
Kuhl, D T13-2D
Kuhn, P-H T1-8D
Kuhn, S T18-12D
Kühn, M T12-2B, T15-9B
Kühn, N T15-3D
Kühn, S T12-2B, T15-9B
Kuklan, J T19-9B, T19-13C
Kulik, A T5-1B, T8-2B, T11-12D
Kulkarni, MM T11-4B
Kullmann, J T10-5B
Kumar, A S3-5, T16-3D, T24-3A
Kummer, M T16-10C
Kuner, T T7-7B, T7-4C, T7-9D, T19-1B
Kunkel, S T11-13D, T26-8B
Kuntz, S T25-3D
Kunz, L T4-2D, T18-11D, T27-4A, T27-1C
Künzel, T T18-8A
Küpper, M T19-15B
Kupsch, D T6-2C
Kurps, J S7-2
Kurschus, F T12-4D
Kurt, S S6-6
Kurth, S T2-3D
Kurtz, R T14-2C
Kusch, J S18-2
Kuznetsova, T T2-3A
Kwon, EJ T7-5B
Kyereme, J T19-14C

Author Index

A B C D E F G H I J K L M N O P Q R S T U V W X Y Z

- Lagnado, L S2-2
 Lahut, S T11-5C
 Lakemeyer, G T18-2D
 Lakes-Harlan, R T3-3C, T17-1C, T17-2C
 Lamkemeyer, T T6-2A
 Lampl, I S9-2
 Lancier, S T24-8B
 Landgraf, M S22-2
 Landgraf, P T2-5C
 Lang, W T27-2A
 Langemann, H T11-11B
 Langer, J T9-1B
 Langlhofer, G T21-7D
 Lashgari, R T16-5D
 Laspas, P T12-4C
 Laßek, M T7-1A, T7-2A
 Lau, T T4-1A
 Lauks, J T7-10B
 Lavista-Llanos, S T19-2B
 Lazarevic, V S7-6, T7-10D
 Lázaro, DF T11-5A
 Lazarov, E S9-6, T26-11D
 Le, Q T6-5A
 Le Conte, Y T8-4B
 Leebhardt, F T14-3A
 Leboulle, G T25-12D
 Lechner, SG T20-1B
 Lee, A T17-4D
 Lee, BR T13-5D
 Lee, C T8-1A
 Lee, CC S6-4
 Lee, HS T16-1B
 Lee, MM T11-3B, T25-4C
 Lee, SC T17-6B, T18-6B
 Lee, Y-H T26-9A
 Legler, C T18-7A
 Legon, W T26-7C
 Lehmann, F-O T21-4B, T21-1D
 Lehmann, K T3-2D, T16-7B, T21-2D, T25-2A
 Lehmann, R T19-14A
 Lehmann, S T26-4B
 Lehmann, SJ T21-6A
 Lehnert, S T18-10B
 Lehotsky, J T13-2B
 Lei, J T16-4D
 Leibinger, M T12-2D
 Leibold, C T16-8D, T18-10B
 Leitinger, G T11-5D, T14-2A
 Lemesre, V T11-4C
 Lemos M. Rodrigues, M T20-2A
 Lenarz, T T17-4A
 Lenk, K T26-2D
 Lenz, C T7-1B
 Lenz, M T8-2D, T8-4D
 Leonhardt, A T27-5B
 Lesch, K-P T13-5A, T13-7C, T13-1D, T25-4C
 Lessing, N T24-9B
 Leßmann, V T7-1C, T8-1C, T8-6D, T8-7D, T11-9B, T11-8C, T11-11C, T25-12B
 Lessner, G T1-4A
 Letzkus, JJ T25-11A
 Lévi, S S21-2
 Levina, A T26-3A
 Lewa, C T25-1B
 Lewejohann, L T25-4C
 Lewen, A T11-8B
 Lewin, GR T20-1B
 Li, B T13-3A
 Li, J T1-3A
 Li, J-Y S14-5
 Li, Q T8-2C
 Li, X T16-5D
 Liang, Y T19-16D
 Lichtenthaler, SF T1-8D
 Liebau, A T18-5D
 Liebau, S T11-1B
 Lien, C-F T9-3C
 Lievens, PM-J T2-3A
 Liewald, JF T6-1D, T8-7B, T25-6D
 Lim, J S8-4
 Lin, K-H T1-1D, T7-6C
 Lindner, A T26-2A
 Lingner, A T18-1D, T18-9D
 Lingor, P T3-1C, T11-1A, T11-7B, T11-10C
 Lippmann, K S20-6
 Liu, J T15-3C
 Liu, R-F T24-5A, T24-10A
 Liu, Y T8-6C

Llano, I T8-3D
Loch, D T19-21C
Löchner, M T3-2B, T9-2A
Loehfelm, A T25-13D
Loewel, S T16-4C
Lohmer, S T19-8A
Löhner, M T15-2A
Lohr, C T9-6B, T9-4C
Lopes da Fonseca, TRdS T11-6A
Lorenz, P T6-3C
Löscher, W T11-3C, T11-13C, T13-5B
Löwel, S S5-7, T15-6C, T16-2A, T16-3A, T16-7A,
T16-9C, T27-5A
Lübbert, M T19-14C
Lübkemeier, I T1-3C
Lublinsky, S S20-6
Lucas, P T19-19D
Lüdke, A T19-2D
Luedke, J T25-11A
Luh, C T12-3D
Luhmann, HJ T2-4A, T6-7C, T10-4A, T12-3D
Lukáčová, N T21-9D
Luksch, H T15-5A, T15-3B, T15-1C, T15-2D, T18-
5B, T18-10D
Lundt, A T17-5B, T23-6C
Lunger, I T7-1A, T7-2A
Lüscher, B S19-6
Lushchak, O T25-15A
Lüthi, A T25-11A, T25-1D
Lynch, M T10-3B
Lyzwa, D T18-6A

Author Index

A B C D E F G H I J K L M N O P Q R S T U V W X Y Z

- Ma, S T18-11B
 Maass, K T1-3C
 Maat, P T12-4B
 Machado, V T11-4A
 Madany Mamlouk, A T26-4D
 Madsen, E S2-5
 Maggi, L S17-2
 Maggio, N T5-1A, T11-12D
 Magis, A T19-6B
 Magnusson, AK T18-3B
 Mahlke, C T13-2D
 Mai, B T24-1D
 Maier, N T23-5D
 Maier, U T27-2B
 Maisonnasse, A T8-4B
 Mak, SK T1-1D
 Mallot, HA T24-8B, T24-10B, T24-1C, T24-2C,
 T24-10D, T27-6D
 Malmierca, MS T18-3A
 Mamasuew, K T19-5C
 Manahan-Vaughan, D T8-6A, T8-3B, T13-1C, T25-
 7C
 Mandon, S S24-6, T27-2A
 Mangus, K T11-10A
 Mann, F S16-5
 Mann, M T9-5C
 Mannewitz, A T25-6C
 Manoonpong, P T23-3D, T25-7D
 Manteniotis, S T19-9A, T19-14A
 Mantziaris, C T21-7B
 Manzini, I T2-3C, T19-6A, T19-15D
 Marcello, L T9-2C
 Marcotti, W T18-12D
 Marder, E P8
 Marguet, S T6-5A, T6-2D
 Marín, GJ T15-2D
 Marini, C S7-6
 Markram, H S7-5
 Marks, V T15-1C
 Marks, VK T24-7B
 Marongiu, D T7-4A
 Martens, A-K T16-3A
 Martens, H T6-5C
 Marter, K T25-1B
 Martin, ND T24-10D
 Martinez, D T19-19D
 Martinez-Trujillo, JC T24-7C
 Martinez-Vazquez, P T21-8C
 Martoncikova, M T19-18D
 Marx, M T2-4A
 Marx, S T26-9D
 Maskos, U T6-3A
 Maslyukov, A T19-16D
 Mason, SO T11-9A
 Massy, J T19-6B
 Masumoto, G T26-8B
 Matheson, T T21-8D
 Matkovic, T S7-7
 Matteoli, M T6-5C
 Matthäus, F T1-7A
 Matthes, S S11-7
 Matyash, V T9-2B
 Maurer, CM T15-5D
 Maw, MA T15-3A
 Mayer, G T21-5C
 Mayer, S T7-9B
 Mayer, U T27-5A
 Mazziotti, R S5-5
 Medendorp, W S15-2
 Mehlan, J T11-11A
 Mehrpour, V T24-7C
 Mehta, MA T24-9A
 Meier, JC S19-4, T11-12D
 Meier, K T26-7B
 Meisel, A T22-2A
 Meller, B T11-4D
 Meller, J T11-4D
 Mellies, N T15-8A
 Meltendorf, S T16-3D
 Mende, S T16-9B
 Mendoza Schulz, A S6-3
 Menz, VK T21-3A
 Menzel, R T14-3C, T25-2A, T25-13A, T25-6B,
 T25-10B, T25-2C, T25-13C
 Menzler, J T15-9C
 Mergenthaler, P T22-2A
 Merkel, O T3-2B, T9-2A
 Merschbaecher, K T25-15B, T25-13D

Merseburg, A T6-5A, T6-2D
Meschkat, M T2-1C
Meseke, M T2-2C
Meuth, SG T23-9A
Mey, J T3-2A
Meyer, A T15-4C, T19-1A, T26-12B
Meyer, A-F T26-5C
Meyer, D T19-15C
Meyer, E T25-11A
Meyer, EP T11-12A
Meyerhof, W T19-15C
Meyer-Lindenberg, A T1-7A
Miceli, S S11-6
Michael, N T27-5A
Michaels, JA T21-6B
Michaelsen-Preusse, K T2-6A, T8-5A
Michalakakis, S T27-4A
Michalski, D T6-5C
Michaud, M T11-4C
Michel, U T3-1C, T11-1A
Michels, B T25-1A, T25-15A
Micheva, KD T7-10A
Miehe, S T25-6B
Miesenböck, G T23-1A
Mikkat, S T1-4A
Milenkovic, I T18-8A
Miljus, N T12-6A
Miller, A-M T10-3B
Miller, M T22-1C
Miller, R T17-5B
MINAKAKI, G S14-4
Mishra, D T25-15A
Mißbach, C T19-11D
Missler, M T27-7B
Mittmann, T T4-2B, T6-4C, T7-4A
Mix, A T23-8D
Mix, E T11-11A
Möck, M T23-3B, T23-2C
Möckel, D T17-3A
Moczulska, K T25-5B
Moeller, LM T19-8A
Moewes, C T13-6C
Mohanta, SK T9-3C
Molkov, YI T23-2B
Moll, F T24-4B
Möller, A T7-6A
Molnar, Z S16-6
Molnár, L T3-2C, T3-1D, T7-11C
Monceau, K T19-5D
Mondin, M S21-1
Montag, D T7-8B, T10-2A
Monteforte, M T7-8D, T23-10A, T23-9D
Montenegro, C S7-6
Monyer, H T15-1A
Morairty, SR T22-1C
Morales, C T15-2D
Morales-Quezada, JL S4-7, S16-1
Morawska, P T26-8D
Morawski, M T18-9A
Morellini, F T6-5A, T6-2D
Morgan, DA T22-3C
Morgenstern, L T25-1B
Morhrmann, R S7-2
Morrison, A T11-13D, T26-8B
Morris-Rosendahl, D T1-2C
Mörschel, M T19-18A
Morton-Jones, R S23-3
Moser, T S6-2, S6-3, T7-1B, T7-6B, T7-2C, T7-7D, T17-2B, T17-2D, T17-4D
Mosienko, V S11-7, T13-6A
Moskaleva, M T24-9C
Moulin, S S13-5
Mpodozis, J T15-2D
Mueller, R T26-2C
Mueller, T T13-3B
Mueller, U S6-1, T1-8B, T25-15B, T25-13D, T25-15D, T25-16D
Muenz, TS T8-4B
Mühlberger, A T20-1D
Mühlenhoff, M T1-5B
Mühler, R T18-4C
Muil, R T25-12C
Mujagic, S T20-2D
Mukunda, L T19-20A, T19-2B
Müller, A T12-2D, T27-3C
Müller, B T7-2A, T10-4B
Müller, CP S11-3
Müller, F T11-5B, T15-1B
Müller, M T10-2C, T10-5C, T27-3B
Müller, N T24-1B
Müller, R T17-5B, T25-4D
Müller, S T7-4D
Müller, T S10-6, T25-2C
Müller, U T7-1A, T8-1D, T25-14B
Müller-Dahlhaus, F T8-4D
Münch, D T19-19A
Munier, FL T20-1B
Munsch, T T7-1C
Mutschler, I T24-3A
Mylius, J T18-7B
Myoga, MH T18-10B, T18-1D

Author Index

A B C D E F G H I J K L M N O P Q R S T U V W X Y Z

Nache, V S18-2
Nadler, L T23-1C
Nagel, M T20-3B
Nagel, SK T25-12C
Nagpal, J T6-1D
Nair, S T12-2C
Napoli, D S5-5
Narula, G T21-9C
Nau, R T12-1C
Naumann, M T25-5C
Naumov, V T17-1D
Nave, K-A T1-6C, T1-4D, T2-5B, T9-6D, T13-3C
Nawrot, MP S13-4, T19-1A, T19-19C, T26-12B, T26-9C, T26-3D
Neef, A S4-6, S9-6, T26-6A, T26-8C, T26-11D
Neef, J T7-1B
Negwer, M S11-6
Neher, T S3-3
Neitz, A T4-2B
Neitz, M S2-6
Neitzel, SD S24-6
Nerlich, J T18-8A
Neu, A T6-5A
Neubert, D T19-14D
Neubert, G T1-7C
Neuhaus, E T19-9C, T19-17C
Neuhaus, EM T19-8A, T19-18B, T19-4C
Neumann, JR T2-6B, T2-1C
Neumann, S S2-6, T11-2D
Neumeyer, A T10-5B
Neumeyer, C T19-4A
Neupert, S T14-2D, T14-3D
Nguyen, A-V T21-5B
Nguyen, T-M T2-4C
Nichtweiß, J S20-6
Nickel, W T9-5C
Nicoletis, M P5
Nieder, A T24-2B, T24-4B, T24-8C, T24-9C, T24-10C, T24-3D, T24-5D, T24-6D, T24-9D
Niederleitner, B T18-10D
Niekisch, H T25-8A
Niemeyer, B T20-3C
Niemminen, M T12-5B
Nieto-Gonzalez, JL T6-5B
Niewalda, T T25-1A
Nikiforuk, A T13-1A
Nikitin, E T26-1C
Nikolaev, A S2-2
Nikolay, P T24-11D
Ninkovic, J T19-18A
Ninkovic, Y T19-16D
Ninnemann, O T1-2C, T1-7C
Nitsche, MA S4-1
Nityanandam, A S16-6, T1-8B
Noack, M T11-7A
Noesselt, T S15-1
Nolte, A T19-7A, T19-20A
Noppeney, U T24-7A
Noristani, R T12-2B
Nothwang, HG T2-6D, T6-6A, T18-6B
Nowotny, M T17-3A, T17-6A
Nowotny, T T19-17A
Nunes, D T19-1B

Author Index

A B C D E F G H I J K L M N O P Q R S T U V W X Y Z

O'Brien, M T8-5A
Oberland, S T19-18B
Obermair, GJ T17-2A
Oehlke, O T6-6D, T6-7D
Oelstrom, K S18-3
Oepen, J-L T26-11B
Oguz, T S10-6
Ohl, FW T18-2A, T18-3D, T18-7D, T25-5C, T26-5C
Oka, Y T19-17B
Okabe, A T6-7C
Oldroyd, BP S8-4
Oliveira, LM T1-1D
Oliver, D T5-3A, T5-1C
Olsson, S T19-10D
Ondrejka, I T13-2B, T13-2C
Oostrik, J T17-4D
Opitz, A T26-7C
Orban, GA T16-5B
Orlandi, J T26-3B
Orlowski, J T24-11D
Ossandon, JP T16-1A
Ostendorf, T T3-1C
Osthold, S T19-9A
Ott, SR S8-3, T25-6A
Ott, T T24-5D
Otte, D-M T23-6C
Oudega, M T3-3B
Outeiro, TF S14-3, S14-6, T11-2A, T11-5A, T11-8A, T11-10C
Ouzir, M T13-4A

Author Index

A B C D E F G H I J K L M N O P Q R S T U V W X Y Z

- Paasch, G-F T24-5B
 Padovani, R T13-4A
 Paeger, L T22-3C
 Paffhausen, BH T14-3C
 Pagani, F S17-2
 Pahle, J T9-1C
 Pakendorf, M T25-15A
 Paliga, D T11-2D
 Palmigiano, A T23-2D
 Pamir, E S13-4
 Pangalos, M T23-5D
 Pangrsic, T S6-2, T7-6B, T17-2D
 Pannicke, T S23-1
 Panzanelli, P S17-2
 Paolicelli, RC S17-2
 Papa, M T5-1A, T9-2C
 Papadopoulos, T T7-9B
 Papageorgiou, IE T11-8B
 Papazoglou, A T6-3B, T17-5B, T23-6C, T23-7C, T25-4D
 Pape, H-C T7-4B, T23-7A, T23-9A
 Paquet-Durand, F T11-4B, T11-2C
 Paquet-Durand, O T11-2C
 Parent, L T6-4D
 Parlak, M T11-3B
 Parthasarathy, S S16-6, T1-8B, T2-2D
 Paschke, K T24-6A
 Pasqualetti, M S11-1
 Pastukhov, A T16-4B, T26-4B
 Pattyn, A T20-1B
 Paul, F T12-5A
 Paul, S T27-2A
 Pauli, P T20-1D
 Pauls, D T21-4D
 Paulus, W T26-7C
 Paupardin-Tritsch, D T5-1D, T27-1D
 Pawelzik, KR S24-6, T26-9B, T26-6C, T27-2A
 Pech, U T19-4D
 Pecka, M T18-11A, T18-1D
 Pedersen, M T7-3B
 Peiker, C T16-3B
 Pelz, T T19-18B
 Penninella, D T8-6B
 Peper, M T24-3A
 Perea, G S20-2
 Pérez de los Cobos Pallarés, F T8-5B
 Peter, M T25-5B, T27-2C
 Peters, J T1-5A
 Peters-Drolshagen, D T27-2A
 Peterson, A T17-1B
 Petrovici, MA T26-7B
 Petsophonsakul, P T8-6D
 Peukert, A T15-2A
 Pfänder, S T11-1B
 Pfeiffer, N T13-6D
 Pfeiffer, T T23-9C
 Pfeil, T T26-3D
 Pflüger, H-J T4-3D, T21-5C, T21-10C, T21-2D, T23-6A, T23-1C
 Picado, D T26-1D
 Picher, MM T17-4D
 Pielecka-Fortuna, J S5-7, T16-2A
 Piepenbrock, D T17-5A
 Pieper, A T1-4D
 Pieper, F T15-7D
 Pilchova, I T11-13B
 Pillai, AG T22-3A
 Pina, AL T12-5B
 Pinho, R T11-8A
 Pirkevi, C T11-5C
 Pirone, A S6-6
 Pirschel, F T20-2C
 Pistor, J T27-2A
 Pizzorusso, T S5-5
 Plath, JA T25-3C
 Plesser, HE T26-8B
 Plested, AJ S18-6, T6-5D
 Pluta, H T24-8D
 Poeck, B T25-2B, T25-3D
 Poggenpohl, L T12-3A
 Polacek, H T13-2C
 Polascheck, N T11-1C
 Polikanova, IS T24-4D
 Polito, M T5-1D
 Pollák, E T3-2C, T3-1D, T7-11C
 Pollard, M T8-3A
 Polleichtner, G T6-6B
 Pölt, P T14-2A

Pompe, S T12-6A
Ponimaskin, E T2-3A
Ponomarenko, A T23-3C
Pons, S T6-3A
Pooryasin, A T19-4D, T25-5D
Popik, P T13-1A, T24-8D
Popivanov, ID T16-5B
Popp, S T11-2B, T11-2B, T13-4C, T13-1D
Poser, R T1-1A
Post, A T11-2B, T11-2B, T13-4C
Pötschke, R T12-1D
Poulet, JF T21-3C
prateek, PK T12-4A
Predel, R T14-2D, T14-3D
Predoehl, F T17-4D
Pregitzer, P T19-13A, T19-2C
Prentzell, MT T1-2D
Preuschoff, S T25-1A
Prigione, A T1-6A
Prinz, N T24-8A
Priwitzer, B T26-2D
Proft, F T13-1D
Proissl, V T4-1A
Prönneke, A T23-3B
Prosch, S T18-8B
Pruss, R T11-4C
Pruszek, J T1-6D
Psotta, L T11-9B, T11-8C
Puelma Touzel, M T23-10A
Pukaß, K T11-10B
Puller, C S2-6
Puskarjov, M S19-3
Putignano, E S5-5

Author Index

A B C D E F G H I J K L M N O P Q R S T U V W X Y Z

Qi, G **T7-8A**
Quentin, C **T7-11A**
Quian Quiroga, R **T21-8D**
Quinlan, EM **S5-6**

Author Index

A B C D E F G H I J K L M N O P Q R S T U V W X Y Z

- Racay, P T11-13B
 Racekova, E T19-18D
 Radchuk, O T13-5C
 Radnikow, G T7-11B
 Radtke, C T9-3B
 Radtke-Schuller, S T18-4D
 Ragazzino, D S17-2
 Rainer, G S1-2
 Raiser, G T27-2D
 Ramahi, J T1-7B
 Ramlochansingh, C T27-5D
 Rasic - Markovic, A T11-7D
 Rau, F T17-1D
 Rautenberg, PL T27-5B
 Ravindran, E T10-1B
 Ravishankar, G T26-6B
 Rechavi, G T11-12D
 Recktenwald, F T24-1C
 Refojo, D T2-4B
 Regazzi, R T8-8A
 Regen, T T12-1C
 Rego, C T11-8A
 Regus-Leidig, H T15-2A, T15-3A
 Reichenbach, A S23-1, S23-2
 Reicherts, P T20-1D
 Reichinnek, S T23-9B, T23-9C
 Reif, A T13-5A, T13-4C
 Reifenberg, K T8-2D
 Reim, K T7-3B, T15-4A
 Reim, T S8-5
 Reimers, K T9-3B
 Reimers, L T13-2A
 Reinehr, S T12-4C, T15-9B
 Reinhardt, V T19-4A
 Reiser, G T5-2D
 Reisinger, E S6-2, T17-2B, T17-2D
 Relo, A T13-2A
 Remme, M T26-2B
 Remus, A T2-6A, T8-4A
 Remy, S S19-5
 Ren, Z S19-6
 Renden, R T7-7B
 Renner, M S21-4
 Rennertz, J T25-14B
 Renninger, C T4-3A
 Requardt, RP T1-3C
 Rether, K T25-15D
 Rettenmaier, A T17-4A
 Rettig, J T20-3C
 Reupsch, J T15-6A
 Reuss, B T2-5D
 Reuter, G T17-4A
 Reuter, K T20-1B
 Revah, O T23-8B
 Rhamouni, K T22-3C
 Rhee, J-S S7-4
 Riabinska, A T12-5B
 Ribes, S T12-1C
 Richter, F T11-4C
 Richter, K T2-5C, T8-4C
 Richter, M T27-2A
 Richter-Landsberg, C T11-3A, T11-7A, T11-10B
 Rickert, CH T1-2C
 Riedel, A T25-9C
 Riedel, T T6-7B
 Riedemann, M-T T6-6C
 Riederer, P T11-3B
 Riegel, A-K T18-2B
 Riehle, A S24-2, T21-3D
 Rieke, F S2-7, T7-3D
 Riemann, S T23-3A
 Riemensperger, T T22-1B, T25-16B
 Riemensperger, TD T25-5D
 Rien, D T14-2C
 Ries, A-S T24-3B
 Rilka, J T12-3B
 Rillich, J S8-2, T24-3C, T24-4C
 Rind, FC T14-2A
 Ringwald, J T10-3A
 Rippberger, H T10-1C
 Ritzau-Jost, A T7-9A
 Rivero, O T13-7C
 Rizzoli, S T11-6A
 Roberts, A T23-4A
 Robinson, GE T19-6B
 Rocha, A T9-2B
 Rochefort, N P3, S5-1, T16-1D
 Rockahr, C T11-8C

Röckle, I T1-2B
Röder, B S15-5, T20-3D
Rodrigues, E T11-5A
Roeber, S T11-7B
Roeder, T T27-6B
Roemschied, F T26-3C
Roesler, M T12-6A
Roesner, J T6-7A
Rogers, SM T25-6A
Rohbock, K T18-12D
Röhrich, WG T24-2C
Roidl, D T1-6D
Rolfs, A T1-5C
Rolke, D S8-6
Rolls, E S3-1
Rolloff, F T9-3B, T9-5B
Romo-Parra, H T6-8A
Ronacher, B T14-3A, T17-3B, T26-3C
Rosário, M T2-3B, T2-2D
Rose, CR S20-4, T9-1B
Rose, J T24-4C
Rosenbaum, P T21-2B, T21-2C
Rosenberger, G T2-2C
Rosengauer, E T2-6D
Rosenmund, C T7-7A
Röser, A T24-10B
Rosner, R T14-1B, T14-1C
Rossini, PM S4-5
Roskopp, J T8-4D
Rosskothén-Kuhl, N T18-10C
Rössler, W T8-4B, T14-1D, T19-1A, T19-5A, T19-16B, T19-1C, T25-7B, T26-12B
Rossner, MJ S20-3, T10-4C, T12-4A, T13-1B, T25-3A
Roßner, S T11-6B, T11-6C
Rotermund, D S24-6, T26-5B, T27-2A
Rotermund, N S23-5
Roth, FC T23-1B
Rothkegel, M T2-6A, T9-6A
Rotte, C T19-2A, T19-11A, T19-5B, T21-8A
Rottner, K T8-5A, T9-6A
Roussa, E T6-6D, T6-7D
Rowlands, A T26-7C
Roy, S T19-10C
Rozenblit, F T15-7C
Rubel, EW T18-1A
Rubio, ME T18-11C
Rübsamen, R T18-9A
Rudenko, A T7-5B
Rudnicki, A T2-6D
Rudolph, R T9-6C
Ruhl, T T10-1D, T24-8A
Ruhrmann, S T26-2C
Ruiz, S T19-14D
Rumman, M T3-2A
Rumpel, S S6-5, T25-5B, T27-2C, T27-5C
Rusakov, DA S7-6
Rust, M S12-5, T10-5B
Rüther, U T22-2C
Rutherford, MA T7-6B, T7-2C
Rutishauser, U T26-9D
Rüttiger, L S6-4, T8-7C, T10-4B, T17-6B, T18-6B, T18-12D
Ruusuvuori, EM S19-2
Ryan, AF S23-3
Rybak, IA T23-2B
Rybak, J T19-8D, T19-14D
Ryglewski, S S22-1
Rygula, R T24-8D
Ryu, S T15-5D

Author Index

A B C D E F G H I J K L M N O P Q R S T U V W X Y Z

- Saal, K-A T11-7B
 Sabel, BA T13-6C
 Sachse, S T19-3C, T19-18C, T19-8D
 Sachser, N T25-4C
 Safavi, S T26-6B
 Sahaboglu, A T11-2C
 Sajikumar, S T8-2C
 Salazar, H T6-5D
 Saldeitis, K T18-3D
 Salkovic-Petrisic, M T11-3B
 Salmen, B T6-7A
 Samtleben, S T27-6A
 Sanchez Caro, JM S6-3
 Sandoz, J-C S13-5, T19-5D, T19-6D, T19-13D, T25-10C
 Sansone, A T19-6A, T19-15D
 Santos-Torres, J T6-3A
 Sareen, P T24-4A
 Sarey Khanie, M T16-9B
 Sargsyan, V T19-2B
 Sarikaya, A T24-10D
 Sass, H T21-1A
 Satheesh, SV T2-6D, T18-6B
 Sauer, J-F T13-4B
 Sauer, M T7-8C
 Saumweber, T T25-2D
 Savage, S S10-6
 Savanthrapadian, S T7-5C
 Savaskan, NE T1-4B, T11-12A
 Schachner, M T23-4D
 Schachtner, J T4-1B, T19-8B, T19-6C, T19-7D, T19-9D, T19-12D
 Schaefer, N T6-4B
 Schäfer, K T12-6A
 Schäfer, M T7-6A
 Schäfer, MK-H T11-12C
 Schäfer, ST T1-5A
 Schaffelhofer, S S24-4, T21-3A
 Schaible, E-V T12-3D
 Schanze, D T7-11D
 Schanze, T T27-4B
 Schapals, A T19-1D
 Scharff, C T25-11D
 Scheel, M T12-5A
 Scheibe, S T27-2D
 Scheiblich, HC T9-5B
 Scheich, H T18-7B, T18-3D, T18-4D
 Scheiffele, P T2-4C
 Scheiner, R S8-5, T4-2C
 Scheld, M T3-2A
 Schellenberg, T T27-2A
 Schemmel, J T26-7B
 Schendzielorz, T T14-3D, T19-4B
 Scherberger, H S24-4, T21-3A, T21-6A, T21-6B
 Scherf, N T2-2B
 Scheunemann, L S13-2
 Schick, B T17-2A, T18-12D
 Schicker, K T6-1B, T15-5C
 Schildt, S T8-6D
 Schimmang, T S6-4, T18-6B, T18-12D
 Schindler, D T10-1B
 Schirmer, K T19-4B
 Schlaak, JF T12-3A
 Schleicher, S T19-2A, T19-5B
 Schleimer, J-H T26-3C
 Schlenker, D T17-1A
 Schloss, P T1-7A, T4-1A
 Schlueter, OM T8-6C
 Schlumbohm, C T11-4D, T22-2D, T27-1A
 Schlusche, AK T6-2D
 Schlüter, A T4-1A
 Schlüter, O T7-9C, T13-5D, T16-8C
 Schlüter, OM T7-2B, T8-8B, T16-9C
 Schmeer, CW T9-5D
 Schmeichel, B T19-19A
 Schmeltzer, CC T26-12D
 Schmid, H T12-4D
 Schmidt, A T2-4C, T7-8D, T19-9B
 Schmidt, H T7-9A
 Schmidt, J S22-4, T21-8A, T21-10B
 Schmidt, KE T16-3B
 Schmidt, K-F T16-3A, T16-7A, T16-8C, T16-9C
 Schmidt, M T22-3A, T26-8B, T26-10D
 Schmidt, R T8-6B, T8-3C, T25-11B
 Schmidt, S S4-4
 Schmidtke, D T10-3D, T25-4B
 Schmidt-Samoa, C T16-1C, T23-8C
 Schmitt, A T4-3A

Schmitt, AG T11-3B, T13-7C, T25-4C
Schmitt, C T25-6D
Schmitt, FV T14-1D
Schmitt, O T1-4A, T11-11A, T26-8D
Schmitz, D T6-7A, T23-5D
Schmitz, J T21-3B
Schmitz, M T25-12C
Schmuker, M T19-19C, T19-8D, T26-4C, T26-3D, T26-4D
Schnabel, M S5-3, T16-4C
Schnaitmann, C T14-3B
Schneggenburger, R S7-3, S7-5
Schneider, A T19-7C
Schneider, AC T18-12C
Schneider, M T27-2A
Schneider, R S21-5
Schneider, T T6-4D
Schnell, C T9-5A
Schnichels, S T12-1A, T12-2A
Schnurr, A T3-3C
Schnyder, HA T18-5B
Schöbel, N T19-14A, T19-14C
Schober, A T11-4A
Schoch, S S19-5, T15-2A
Schoene, C T7-11D
Scholl, C T25-7B
Scholz, C-J S10-6
Scholz, H T4-1C, T19-7C, T21-5D
Scholz, P T19-8C
Schöne, K T9-4D
Schöneich, S T23-4B
Schopf, C T18-6D
Schottdorf, M T15-6D
Schramm, G T27-6B
Schrauwen, I T17-4D
Schreiber, S T17-1D, T26-10A, T26-2B, T26-3C
Schreiberová, A T21-9D
Schreiner, AE T9-1B
Schreiner, B T19-14A, T19-11B
Schreiner, C T20-3A
Schreiner, D T2-4C
Schröder, S T1-9B
Schroeder, OH-U T26-2D
Schroedl, M T6-7D
Schubach, T T7-1A
Schubert, D S11-6
Schubert, M T23-6A
Schubert, T S2-1, T11-4B, T15-4B
Schuele, B T1-1D
Schuermann, F S7-5
Schuh, J T14-1B
Schukat-Talamazzini, EG T26-6D
Schuller, JM T16-6B
Schultheiss, M T12-1A, T12-2A
Schultz, C T2-1D, T7-10C
Schultze, A T19-12A
Schulz, AL T18-7D
Schulz, E S18-2
Schulz, S T6-4B
Schulze, H T18-5A, T18-9B, T18-3C
Schulze, J T14-2D, T14-3D, T19-4B
Schulze-Bonhage, A T24-3A
Schuman, EM P6
Schumann, F T25-12C
Schümann, A T1-4A
Schuster, S T2-3B, T2-2D
Schütt, M T26-13D
Schütz, M S12-3
Schütz, S T19-9D
Schütze, H T25-15C
Schützner, P T21-1D
Schwab, M T1-4D
Schwab, ME T8-7A, T8-5C
Schwab, MH T1-6B, T1-6C, T2-5B, T13-3C
Schwabe, K T11-1C, T11-9C, T13-6B
Schwack, W T19-3B
Schwandt, J T24-6C
Schwarting, RKW T10-2B, T10-1C, T10-3C, T22-3D
Schwarz, A T21-7B
Schwarz, G S19-7, T6-2A, T11-12D
Schwärzel, M S13-2
Schweinhuber, S T9-6A
Schweitzer, BC T6-1A
Schweppe, C T13-6A
Schwert, H T4-3A
Schwesig, G T25-14D
Schymura, D T19-12A
Scianni, M S17-2
Sebert, N T13-3B
Seebacher, C T27-1C
Seeger, G T18-9A
Seffer, D T10-1C
Segal, M T5-1A
Sehm, T T1-4B
Seibel, K-O T2-3D
Seiberlich, V T11-3A
Seidel, VG T10-1A
Seidenbecher, CI T7-8B, T8-2A
Seidl, AH T18-1A
Seidler, NW T11-9A
Seifert, B T11-11C
Seifert, G T11-9D
Seiler, A T1-7C
Selcho, M T23-4C
Sellami, A T22-1D
Selten, M S11-6
Seltmann, S T25-8B

Semak, M T11-2A
Sendelbeck, A T15-4A
Senkov, O T23-4D
Senthilan, PR T17-5A
Seo, J T7-5B
Sergeeva, EG S4-2
Serr, P T19-18A
Sestan, N S19-2
Shaaban, A T5-2D
Shaban, H T8-3A
Shah, M T6-2D
Shakeri, B T6-4D
Shao, H T10-2D
Sharopov, S T6-7C, T10-4A
Shea, SD T19-12B
Sheean, ME T20-1B
Shen, Q S19-6
Shenoy, K P4
Shukla, A T7-9C
Sibarita, J-B S21-1
Sibbe, M T1-3A
Sich, SA T13-7C
Sieben, K T20-3D
Siebert, M S7-7
Siegert, S T7-5B
Siegrid, L T16-8C
Siehler, O T25-12A
Sigrist, SJ S7-7, T7-11A, T21-2D
Silbering, AF T19-19A
Silingardi, D S5-5
Sillevis-Smitt, P T12-4B
Simicevic, J T2-4C
Simons, M T11-6D
Simpson, S T24-4C
Singer, W S6-4, S10-2, S10-3, T8-7C, T16-1B, T17-6B, T18-12D, T27-1B
Singh, A T6-1B
Singh, JB T8-2A
Singh, V T9-5B
Singheiser, M T18-12A
Sirota, A T25-14D
Siveke, I T18-8C, T18-1D
Siwek, ME T6-3B, T23-7C, T25-4D
Skandalis, D T21-4B
Skorupa, J T24-6B
Skripuletz, T T1-5B, T9-2D
Slimak, MA T6-3A
Slovin, H S24-7
Smalla, K-H T2-5C, T7-8B, T8-4C, T10-2A, T25-5C
Smarandache-Wellmann, C T21-5A, T21-7A
Smith, JC T23-2B
Smith, RG S2-4
Smith, SJ T7-10A
Smolinsky, B T11-12D
Smuda, J T7-6D
Sobolev, A T27-5B
Socala, K T13-5B
Soelter, J T19-8D
Soffe, SR T23-4A
Sokoll, S T27-7B
Solecki, DJ S12-1, T1-7B
Sommen, M T17-4D
Sommer, C T11-2B, T11-2B
Sommer, M-V T22-1B
Somogyi, I T3-1D
Song, J T5-1B
Sonntag, M T18-9A
Sonntag, S T15-1A
Sørensen, JB S7-2
Soreq, H T11-8A
Soreq, L T11-8A
Soriano, J T26-3B
Sosiedka, I T13-5C
Soto-Bernardini, MC T13-3C
Soykan, T T7-9B
Spatz, A-K T25-2C
Specht, A T27-3A
Speck, O T16-3D, T16-4D
Speer, JM T6-6D, T6-7D
Spehr, J T19-8A, T19-13B
Spehr, M T19-8A, T19-16A, T19-13B, T19-4C, T19-9C, T19-17C
Spigolon, G T11-12B
Spittau, B T11-4A, T12-3B
Spitzer, MS T12-1A, T12-2A
Spoida, KM T15-7A
Sprekeler, H T26-7A, T26-2B
Sprengel, R T13-6D
Spröwitz, A T25-9C
Srivatsa, S S16-6
Stadler, J T16-3D
Staiger, JF T2-2A, T16-3A, T23-3B, T23-2C
Stampanoni, M T11-12A
Stange, A T18-1D
Stangel, M T1-5B, T9-5B, T9-2D
Stanojlovic, O T11-7D
Starunov, VV T2-1A
Stavermann, M T9-4C
Stebe, S T19-5C
Steckler, T T8-3A
Steib, A T3-2C
Stein, V T2-4B
Steinhäuser, C T1-3C, T11-9D
Steinke, M T4-3A
Stemmler, T T24-6B
Stengl, M T14-2D, T14-3D, T19-7A, T19-20A, T19-4B, T19-20C, T23-6B, T23-5C

Stensmyr, MC T19-19B, T19-10D, T19-11D
Stephan, J T9-3D
Stephan, VM T24-10A
Stephen, V T24-5A
Stepien, AE T21-9C
Stern, M T3-1A, T9-5B
Stetter, O T26-3B
Steuer Costa, W T8-7B
Stevenson, PA S8-2, T21-5C, T24-3C, T24-4C
Stieb, SM T14-1D
Stierle, JS T19-10A
Stiess, M T9-5C
Stitt, IM T15-7D
StJohn, JA T9-4C
Stock, MC T9-1B
Stöckl, A T26-1A
Stockner, T T6-1B
Stodieck, SK T16-7A
Stoenica, L T11-12D
Stoll, J T16-9B
Stoltenburg-Didinger, G T1-2C
Stolz, T T21-10B
Stonkute, S T16-4B
Stork, O T13-3D
Stoykova, A T1-3B
Straka, H T16-6B, T17-3C, T17-4C, T21-7C, T27-1C, T27-5D
Straumann, D T16-6D
Strauß, J T20-1C
Strauss, R S22-5, T21-1A, T24-3B, T25-2B, T25-3D, T26-11B
Strauss, S T9-3B
Strehl, K T10-1B
Strenzke, N S6-2, S6-3, T7-1B, T7-6B, T17-2D
Ströh, S T15-1A
Strotmann, J T19-3B, T19-11C, T19-21C
Strube-Bloss, MF S13-3
Strüber, M T13-4B
Strutz, A T19-3C, T19-18C, T19-8D
Stühmer, W S9-6
Sturm, R T1-8C
Stutzki, H T15-9C
Sun, C S19-6
Sun, H T6-7C, T10-4A
Sun, P T11-3B
Sungur, AÖ T10-2B, T10-3C
Sur, M S20-2
Suriya-Arunroj, L T21-9B
Susic, V T11-7D
Suska, A T13-5D
Sutor, B T6-6C
Svara, F T15-5D
Swinny, J T9-3C
Syed, AS T19-15D

Sygnecka, K T2-2B
Szegő, ÉM T11-2A
Szkudlarek, H T7-4B, T23-9A
Szyszka, P T19-10A, T19-2D

Author Index

A B C D E F G H I J K L M N O P Q R S T U V W X Y Z

- t Hart, M T16-9B
 Tabatabaiefar, MA T17-4D
 Taghizadeh, B T21-8B
 Takago, H T7-7D
 Takeshita, D T15-8B, T15-2C
 Talarico, G T19-14D
 Taniguchi, H T13-3A
 Tanimoto, H S10-6, S13-1, T14-3B
 Tantalaki, E T19-6A, T19-15D
 Tarabykin, V S16-3, S16-6, T1-8B, T1-6C, T1-4D, T2-5B, T2-2D
 Taschenberger, G T11-11D
 Taschenberger, H T1-1D, T7-3B, T7-6C
 Tatenhorst, L T11-10C
 Taubert, M T26-2C
 Tchaptchet, A T6-2B
 Tchumatchenko, T T23-8B
 Teichert, M T3-2D
 Telang, RS S23-3
 Teli, MK T12-1B
 Tellers, P T18-12A, T18-7C
 ter Maat, A T18-11B, T25-7A, T25-9B
 Tereshchenko, Y T11-11D
 TerMaat, A T25-8B
 Terzi, MY T12-5B
 Tetzlaff, C T25-13B, T26-10C
 Tetzlaff, T T11-13D, T26-7B, T26-11C
 Thal, SC T12-3D
 Thamm, M S8-6, T4-2C
 Theden, F T13-2D
 Thedieck, K T1-2A, T1-2D, T1-8D
 Theilmann, W T13-5B
 Theis, M T1-3C
 Theisen, CS T11-9A
 Theparambil, SM T9-1A
 Theunissen, LM S22-6, T21-6D
 Thiel, CM S1-6
 Thiel, U T6-3C
 Thiele, A S1-1
 Thiéry, D T19-5D
 Thoma, M T19-20B
 Thomas, E T15-4B
 Thomas, U S21-5, T12-1D, T27-4B
 Thome, C T7-10C
 Thon, S S18-2
 Thorne, PR S23-3
 Thoumine, O S21-1, T2-4D
 Thuma, JB T27-4C
 Thurley, K T16-8D
 Thyssen, A T9-4C
 Tietje, K T27-6B
 Timaru-Kast, R T12-3D
 Timme, M T26-10C
 Tinnes, S T10-3A
 Tinter, J S6-5, T25-5B
 Tippmann, A T27-2B
 Tireli, H T11-5C
 Tischmeyer, W T8-4C
 Toepfer, F T24-1A
 Tognini, P S5-5
 Töllner, K T11-3C, T11-13C
 Toloe, J T11-11D
 Tolstosheeva, E T27-2A
 Tomas Roig, J T22-1A
 Tömen, N T26-5B
 Tonevitsky, AG T24-4D
 Tönges, L T11-7B, T11-10C
 Toonen, R S7-3, T7-10B
 Torre, E T26-1D
 Toteva, A S8-5
 Tovar, S T22-3C
 Tovote, P T25-11A
 Toyka, KV T11-2B, T11-2B
 Trampe, A-K T15-7A
 Trattner, B T4-2D, T18-11D
 Trauner, D S18-1, T6-1D
 Trebels, B T4-1B
 Trepte, P T7-6A
 Treue, S T16-1C, T16-7D, T24-2A, T24-5A, T24-10A, T24-11A, T24-1B, T24-7B, T24-7C
 Treuter, N T11-2D
 Trilck, M T1-5C
 Triller, A S21-4
 Triltsch, M T25-9A
 Trimbuch, T T7-7A
 Trippler, M T12-3A
 Trivedi, CA T15-5D
 Trivedi, N T1-7B

Tron, N T17-1C
Tropiano, M T11-12B
Trost, L T18-11B, T25-7A, T25-8B, T25-9B
Trowell, S T19-17A
Truccolo, W S24-1
Tsai, L-H T7-5B
Tsetlin, V T6-3A
Tsigankov, D S5-3
Tsodyks, M T26-10C
Tukaiev, S T13-5C
Tünsmeier, J T18-6D
Tuoc, TC T1-3B
Tüttemann, M T23-3D
Tyler, WJ T26-7C
Tziridis, K T18-5A, T18-9B, T18-3C
Tzvetanov, T T16-6C

Author Index

A B C D E F G H I J K L M N O P Q R S T U V W X Y Z

Ueffing, M T11-2C
Uhlig, M T26-3A
Ulfig, N T1-4A
Unsicker, K T11-4A
Unterbarnscheidt, T T13-3C
Unterer, B T21-7D
Urbanke, H T25-5D
Urlaub, H T7-11A
Urra Quiroz, FJ T7-9D
Urushima, T T6-1D
Utikal, J T1-7A

Author Index

A B C D E F G H I J K L M N O P Q R S T U V W X Y Z

- v. Wrangel, C T11-9C
 Vaiceliunaite, A T16-8A
 Vajkoczy, P T12-5B
 Valenzuela, J-C T8-2A
 van Aerde, K T7-8A
 van Albada, S T26-10D
 Van Camp, G T17-4D
 van Coevorden - Hameete, MH T12-4B
 van de Linde, S T7-8C
 van der Doelen, R S11-4
 van Hemmen, JL T17-5C
 van Rossum, D T12-1C
 van Ruitenbeek, P T24-9A
 van Stijn, S T16-1B
 Vancura, P T7-2A
 Vanderelst, D T18-5B
 Vanduffel, W T16-5B
 Varakina, K T10-4B
 Várhalmi, E T3-1D
 Vasileva, M T7-7B
 Vasmer, D T25-5D
 Vaucher, E S1-4
 Veenstra, JA T22-1D
 Vega-Zuniga, T T15-1C, T15-2D
 Veit, J S1-3
 Veit, L T24-6D
 Veit, M T11-9B
 Veitinger, S T19-8A
 VEKRELLIS, K S14-4
 Velanac, V T13-3C
 Vercelli, A T11-12B
 Verderio, C T6-5C
 Vergoz, V S8-4
 Verhaal, J T15-3B
 Verhage, M S7-2, S7-3, T7-10B
 Verhagen, LA T22-2C
 Verhey, JL T18-2A, T18-4C
 Veruki, M S2-5
 Vezzali, R T1-2A, T1-9C, T1-2D
 Vida, I T5-1B, T7-5C
 Vikram, S T21-6D
 Villacorta, JAV T26-11B
 Villmann, C T6-4B, T21-7D
 Vincent, P T5-1D, T27-1D
 Vinck, M T23-7D
 Vinnakota, K S17-5
 Viswanathan, P T24-8C
 Vitay, J T26-1B
 Vlachos, A T8-2D, T8-4D
 Vlachos, I T24-3A
 Vlajkovic, SM S23-3
 Vogel, AS T13-6D
 Vogel, H T19-19B, T19-20C
 Vogel, T T1-2A, T1-9C, T1-2D, T1-3D, T1-6D, T1-8D
 Vogels, R T16-5B
 Vogelsgang, J T11-11B
 Voges, N T19-19D
 Vogl, A T2-4B
 Vogt, MA T1-1A, T13-6D
 Vogt, SM T25-10D
 Vogt-Weisenhorn, D T11-10D
 Voigt, A T19-15C
 Voigt, BC T21-3C
 Voigt, MB T18-5D
 Voigt, S T25-13C
 Voipio, J S19-2
 Volgushev, M T8-1A, T26-1C
 Volkandt, W T7-1A, T7-2A
 von Bohlen und Halbach, O T1-1A, T1-5A
 von Campenhausen, M T18-12A
 von der Emde, G T10-1D, T24-8A
 von Hilchen, CM T1-4C
 von Holst, A T1-9B, T1-1C, T1-8C, T1-7D
 von Marcard, T T23-3D
 von Twickel, A T21-7B
 Vonderschen, K T18-3B
 Voronezhskaya, EE T2-1A, T4-2A
 Vuksanovic, V T26-4A
 Vyssotski, A T21-9C

Author Index

A B C D E F G H I J K L M N O P Q R S T U V W X Y Z

- Wabnig, S T25-6D
 Wache, S T25-12C
 Wachtler, T T14-3B, T15-6B, T16-4A, T16-8D,
 T26-13A, T27-5B
 Wade-Martins, R S14-1
 Wafzig, O T7-4C
 Wagener, RJ T2-2A, T16-3A
 Wagner, H T2-3D, T6-2C, T18-8A, T18-12A, T18-
 7C, T18-9C, T18-2D, T24-11D
 Wagner, HM T25-2B
 Wagner, L S23-2
 Wahane, S T1-2A, T1-3D
 Wahane, SD T1-2D
 Wahle, P T2-6B, T2-1C, T2-1D
 Waider, J T4-3A, T13-1D
 Waisman, A T12-4D
 Wal, A T16-8A
 Walker, F T23-2C
 Walkowiak, W T18-7A, T18-12C
 Walle, HL T11-10C
 Wallrabenstein, I T19-9B
 Walper, D T26-9D
 Walter, AM S7-2
 Walter, J T3-2B, T9-2A
 Walz, B T5-2A
 Walz, H T26-1A
 Wang, S T1-3A
 Wang, T-L T7-2C
 Wang, W T7-5B
 Wang, Y T16-5D
 Wang-Eckhardt, L T11-9D
 Waniek, A T11-6B
 Wanker, EE T7-6A
 Wäring, J T19-12C
 Warmbold, AL T18-4B, T18-8D
 Warren, B T19-2A, T19-5B
 Warriar, DP T22-1C
 Wartenberg, A T19-15C
 Wasser, H T3-1A
 Webb, B S13-6
 Weber, L T19-9B
 Wegener, C T7-11C, T21-4D, T22-1D, T23-4C,
 T27-6B
 Wegener, G T6-5B
 Wehmann, H-N T25-8C
 Wehner, R T14-1D
 Wei, H T23-5C
 Wei, T T15-4B
 Weick, M T15-2C
 Weidinger, JDF T16-3C
 Weidner, M T25-4C
 Weiergräber, M T6-3B, T17-5B, T23-6C, T23-7C,
 T25-4D, T26-2C
 Weigel, S T15-5A, T15-1C
 Weihe, E T11-12C
 Weiler, E T1-5D
 Weiler, R T15-1A, T15-8A, T15-4C
 Weinert, DM T13-4D
 Weingarten, J T7-1A, T7-2A
 Weinges-Evers, N T12-5A
 Weinhold, B T1-2B
 Weinrich, C T23-8C
 Weise, S T1-2A, T1-2D, T1-8D
 Weishaupt, A T11-2B, T11-2B
 Weismantel, R T25-5C
 Weißflog, L T13-5A
 Weisz, CJ T18-11C
 Welker, E T8-8A
 Weller, J T27-3B
 Wellner, B T21-6B
 Wellner, WA T21-6B
 Wende, H T20-1B
 Wendler, S T19-2A
 Wenger, N T8-8A
 Werckenthin, A T23-6B
 Werneburg, S T1-5B
 Werner, A T16-6A
 Werner, C T11-2B, T11-2B
 Werner, M T19-9B
 Wernitznig, S T14-2A
 Wessjohann, L T25-15A
 Wessnitzer, J S13-6
 Westbrook, GL T1-3A
 Westendorff, S T16-2B, T23-7D
 Westerhausen, R S10-4
 Weth, A T19-8A
 Wetzel, CH T6-3D, T12-3C
 Wetzel, F T7-1D

Wetzel, W T18-3D, T25-5C
Wewetzer, K T9-3B, T9-4D
Weyhersmüller, A T7-9A
Whelan, G T15-6C
White, LE T16-4C
Whitney, DE T16-3C
Wibral, M T24-5B
Wicher, D T19-20A, T19-2B
Wichert, S T1-4D, T12-4A
Wichmann, C S6-3, T7-6B, T7-7D, T17-2B
Widman, G T27-2A
Widmayer, P T19-15A, T19-15B, T19-21B, T19-15C
Wieder, L T12-5A
Wiegand, A T22-2B
Wiegrebe, L T18-4B, T18-8B, T18-8D, T18-9D
Wiek, RJ T20-2B
Wierschke, S T6-8B
Wiescholleck, V T13-1C
Wieser, MJ T20-1D
Wilk, AJ T22-1C
Wilke, M T23-7B, T23-8C, T24-2A, T24-6A, T27-1A
Wille, M T1-4A
Willecke, K T1-3C, T15-1A, T15-4C
Willem, M T11-7C
Willer, J T4-3D
Wilms, CD T7-10A
Wimmer, EA T19-9D
Winkelmann, A T11-12D
Winkelkemper, J S9-4
Winkler, J T11-11B
Winter, Y T25-3B
Winterer, J T23-5D
Wirth, MJ T6-2C
Wirtsohn, S T17-3B
Wischmeyer, E T6-8D
Wiskott, L S3-3
Wissinger, B T11-4B, T15-4B
Witke, W S12-3, T10-5B
Witt, A T23-2D
Witte, M T23-2C
Witte, OW T9-5D, T16-2C, T16-10C, T22-2B
Wittenberg, M T16-4A
Wittenmayer, N T7-7C, T7-5D
Wohl, SG T9-5D
Wöhr, M S11-5, T10-2B, T10-1C, T10-3C, T13-6A, T22-3D
Wolbers, T T25-12C
Woldeit, ML T18-7D
Wolf, F S5-3, S9-6, T7-7D, T7-8D, T15-6C, T15-6D, T16-3C, T16-4C, T16-5C, T23-10A, T23-8B, T23-9D, T26-6A, T26-8C, T26-11D
Wolf, R T24-1A, T24-4A, T25-8D, T25-9D
Wolf, S T9-2B
Wolf, SA S17-5
Wolfes, AC S20-7
Wolff, S T25-11A
Wolfgang, T T25-5C
Wolynski, B T16-3D
Womelsdorf, T T23-7D
Wong, AB T7-6B
Wörgötter, F T19-3A, T23-3D, T25-13B, T25-7D, T26-10C
Wormuth, C T24-9A
Wosnitza, A T21-4A, T21-5D
Wree, A T1-4A, T11-4A, T11-11A, T26-8D
Wu, W T17-1D
Wuerfel, J T12-5A
Wunderle, T T16-3B
Wunderlich, FT T22-3C
Wunram, M T27-2D
Wurst, W T11-10D
Würth, S T20-2D

Author Index

A B C D E F G H I J K L M N O P Q R S T U V W X Y Z

Xu-Friedman, MA **T7-6D**

Author Index

A B C D E F G H I J K L M N O P Q R S T U V W X Y Z

Yaari, Y T6-1C
Yakupov, R T16-4D
Yan, K T1-6C, T1-4D, T2-5B
Yanagawa, Y T1-2B
Yang, Z T25-8D
Yanxin Wang, V T21-9C
Yao, T T16-7D
Yarali, A S10-6, T25-1A
Yasuyama, K T23-4C
Yee, N T22-3D
Yonemasu, T T1-4D, T2-5B
Young, JM S13-6
Yu, Q S8-1
Yukin, A S19-2
Yusunov, T S22-2

Author Index

A B C D E F G H I J K L M N O P Q R S T U V W X Y Z

Zablocka, B T9-3C
Zaepf, B T26-11B
Zagrebelsky, M T8-4A, T8-7A, T8-5C
Zähringer, D T18-9C
Zaichuk, M T15-4B
Zajac, M S2-6
Zankel, A T14-2A
Zarnadze, S T23-8A
Zauner, A T25-4A
Zazo Seco, C T17-4D
Zborala, S T19-9B
Zeck, G T11-8D, T15-9C
Zeeh, C T21-1C
Zehendner, CM T12-3D
Zehl, L T21-3D
Zeitschel, U T11-6C
Zerle, J T11-10D
Zessin, S T2-6A
Zeumer, R T25-12A
Zhan, Y S17-2
Zhang, J T1-3C, T11-1A, T27-1D
Zhang, M T1-4D
Zhang, R T23-2B
Zhang, W T1-4D
Zhao, S T1-3A, T10-2D
Zhao, Z T15-1B
Zhu, C T11-4C
Zhukareva, V T11-3A
Ziege, S T9-3B, T9-4D
Ziemann, U S10-1, T8-4D
Zille, M T12-5B
Zima, I T13-5C
Zimmer, A T23-6C
Zimmer, T S18-2
Zimmermann, E T10-3D, T18-6D
Zimmermann, H T9-4B
Zivkovic, AR T23-5D
Zube, C T21-2D
Zuccotti, A S6-4, T8-7C, T18-6B, T18-12D
Zwaka, H T25-13A
Zweckstetter, M T11-8A